

Installation Guide

Mounting

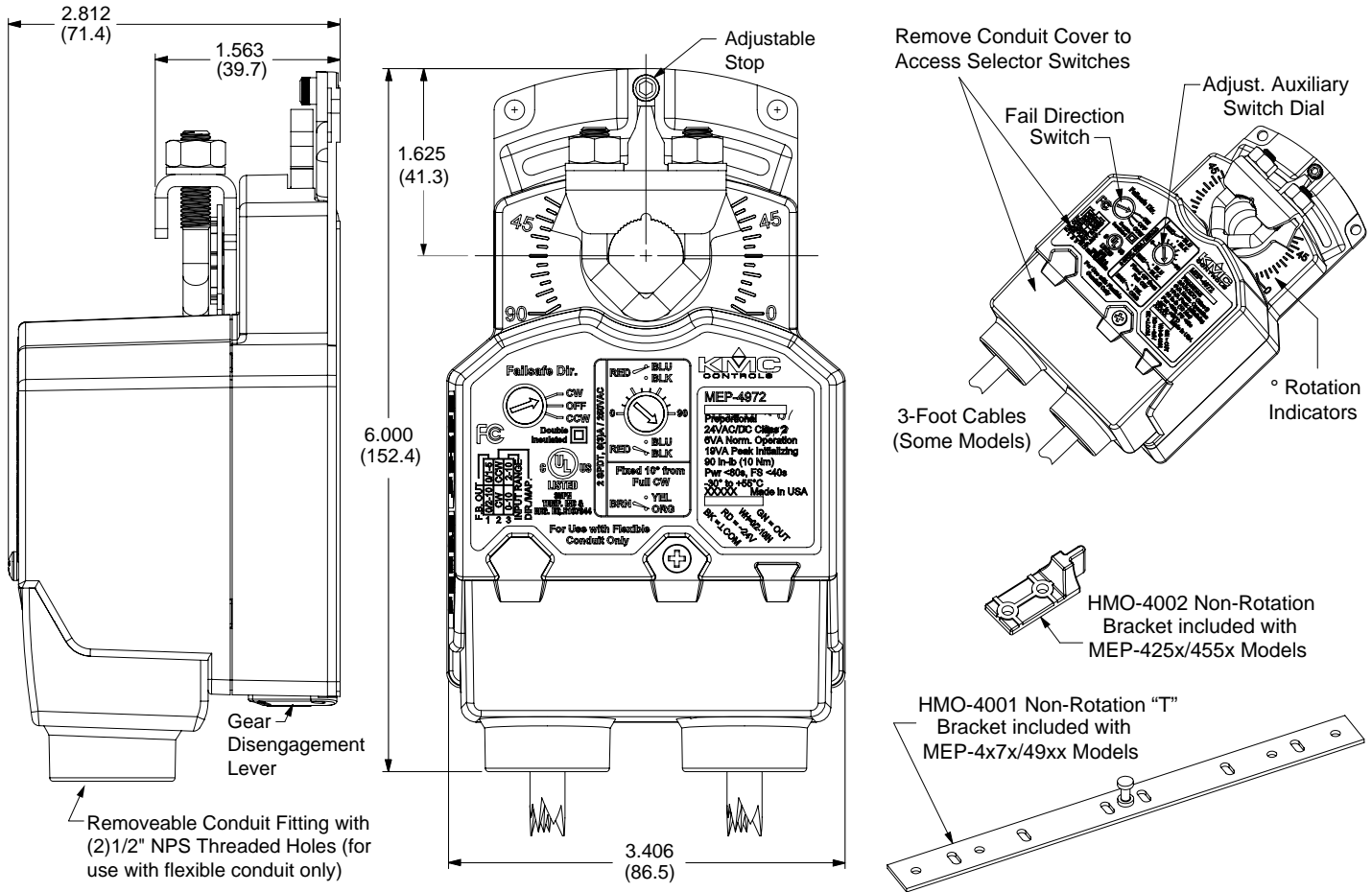

Illustration 1—Overview (Direct-Coupled Mounting)

1. Ensure the damper can move freely through its entire range of motion, and fix any binding before installing the actuator. Turn the damper blade to its fully closed position.
 2. Press (to the right) and hold the gear disengagement lever (see Illustration 1), rotate the actuator to the fully closed position, and release the lever.
- NOTE: Depending on the damper-seal design, backing the actuator off its stop approximately 5° may provide tight damper shut-off.
3. Align the actuator and slide it onto the shaft.
 4. Leaving a gap between the actuator and mounting surface to prevent any binding, finger-tighten the nuts on the V-bolt.
 5. Insert the provided (HMO-4001/4002, dependent on model) non-rotation bracket into the slot at the base of the actuator and secure the non-rotation bracket with two #8 or #10 self-tapping screws.
 6. Evenly tighten the V-bolt nuts (30–35 in-lb. on MEP-42xx models or 60–70 in-lb. on MEP-45xx/49xx models).
 7. If desired, use a 7/64-inch hex key wrench to loosen and position the end-stop screw.
- NOTE: **The two holes at the top of the actuator are NOT for use in direct-coupled applications.** (They are for remote mounting, such as with the optional HLO-4001 Crank Arm Kit.) **For mounting to valves, see the appropriate valve installation guide.**

Wiring

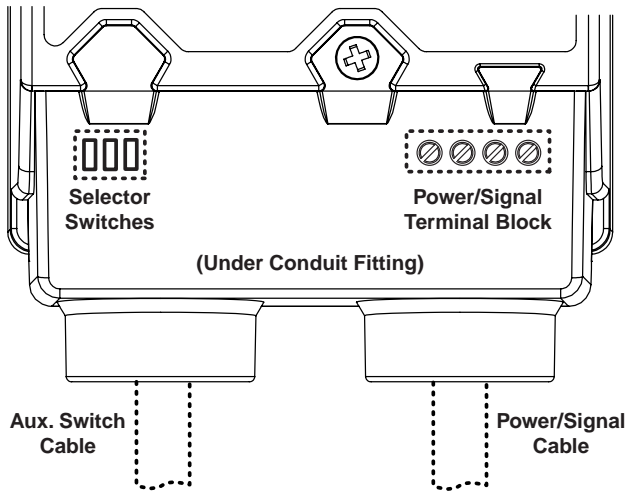

Illustration 2—Cables and Terminal Block Options

⚠ CAUTION	⚠ ATTENTION
<p>Risk of electrical shock. Disconnect ALL power before servicing. More than one disconnect provided on models with auxiliary switches. Failure to follow electrical safety precautions with live electrical components could result in injury or death.</p> <p>If both conduit connections are used, they MUST be externally connected during installation. The nonmetallic enclosure does not provide grounding connection between the two conduit connections.</p>	<p>Risque de choc électrique. Débranchez l'alimentation avant l'entretien. Plus d'un sectionneur fourni sur les modèles avec contacts auxiliaires. L'inobservation des consignes de sécurité électrique avec des composants électriques sous tension peut entraîner des blessures ou la mort.</p> <p>Si les deux entrées de câble sont utilisés, ils doivent être connectés en externe lors de l'installation. Le boîtier non-métallique n'assure pas la connexion à la terre entre les deux connexions.</p>

Depending on the model, signal/power wiring might be to terminals under the conduit fitting **or** to color-coded wires in the attached cable. See Illustration 2. Consult the model label and the appropriate wiring shown in Illustrations 3 through 8.

For auxiliary switch wiring and setting, see [Auxiliary Switch \(MEP-4x7x\)](#) on page 3.

For models **without** the attached signal/power cable:

1. Loosen the screw on the conduit fitting and lift up to remove the fitting.
2. Using a utility knife or drill, cut the red plug to accept wiring or replace the plug with an application-specific fitting.

NOTE: The red plug (or similar fitting) protects internal components from debris, helping to ensure long actuator life.

3. Thread wires through the plugged opening and connect to the terminal block according to the relevant model and application.
4. For MEP-4x2 models, adjust the input voltage range, feedback voltage, direction, and automapping as needed. See [Proportional \(MEP-4xx2\) Models Setup on page 4](#). For MEP-4x51 models, adjust the selector switch as shown in Illustrations 2 and 4–6.
5. Reinstall the conduit fitting and tighten the screw.

NOTE: After initial power-up, proportional models have a 30-second delay of motor operation.

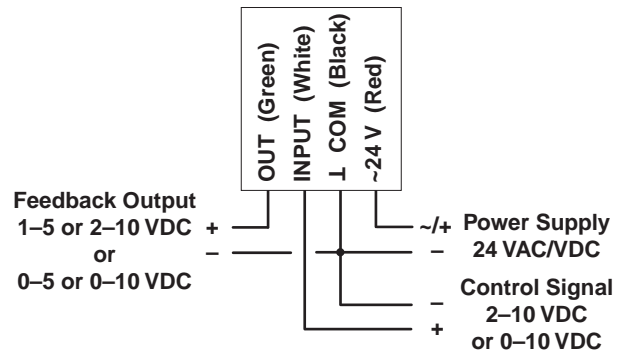

Illustration 3—MEP-4xx2 Proportional Control

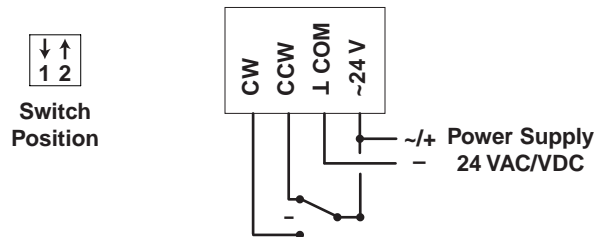

Illustration 4—MEP-4x51 Tri-State Floating Point Control

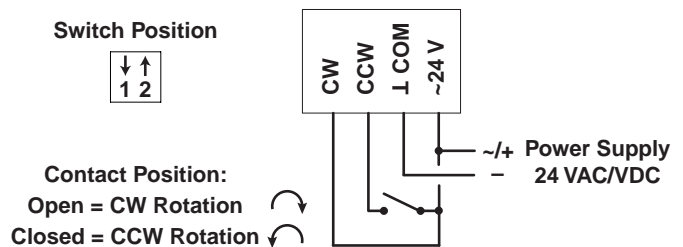

Illustration 5—MEP-4x51 2-Position Control (4-Wire), CCW Leg

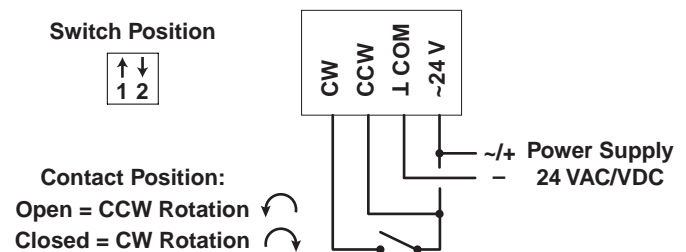

Illustration 6—MEP-4x51 2-Position Control (4-Wire), CW Leg

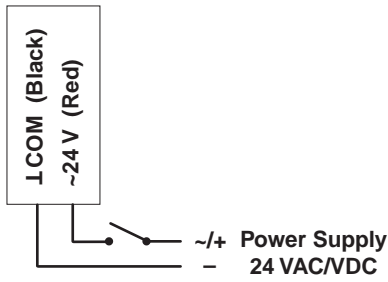

Illustration 7—MEP-4xx4 Two-Position (2-Wire) 24 VAC/VDC

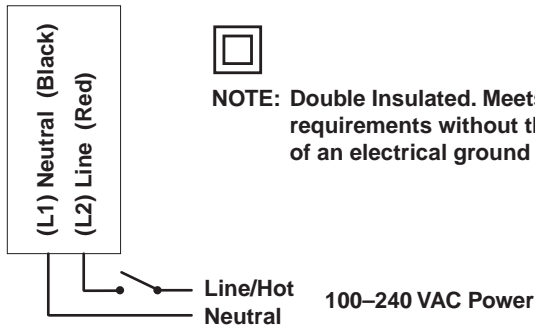

Illustration 8—MEP-4xx5 Two-Position (2-Wire) 100–240 VAC

NOTE: Double Insulated. Meets UL requirements without the need of an electrical ground connection.

Fail-Safe Direction

All models offer selectable fail-safe direction. Proportional and tri-state models also offer the option to turn the fail-safe off (see Illustration 9). Using a small, flat-bade screwdriver, adjust the switch dial to the desired clockwise or counterclockwise direction.

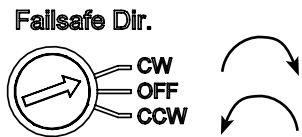

Illustration 9—Fail-Safe Direction Switch Dial

NOTE: After initial connection or reconnection to power on MEP-4xx2 proportional models, proper fail-safe operation might be delayed up to 30 seconds (until the capacitors are fully charged).

Auxiliary Switch (MEP-4x7x)

In MEP-4x7x models, the adjustable auxiliary SPDT switch can be set to trip anywhere between 0° (full CW rotation position) and 90° (full CCW). To adjust the auxiliary switch position:

1. While pressing the gear disengagement lever (see Illustration 1), rotate the actuator to the point where the auxiliary switch should trip.
2. Using a small, flat-bade screwdriver, adjust the rotary dial to “0” (see Illustration 10). As the

actuator rotates, the switch dial arrow will point to the current switch position (Red connected to Blue vs. Red connected to Black). For example, if the switch is set to trip (dial at “0”) when the actuator rotation position is at 45°, then Red is connected to Black from 0° to 45°, and Red is connected to Blue from 45° to 90°.

NOTE: On MEP-497x models, a second switch is fixed at 10° from full CW direction (Brown is connected to Orange in the 0–10° range, and Brown is connected to Yellow 11–90°).

3. Wire the desired auxiliary device(s) to the cable.
NOTE: For more detailed information, see the [MEP-4xxx Application Guide on the KMC web site](#).

NOTE: The SPDT switch is rated for 6 A with resistive load or 3 A with motor load @ 250 VAC.

Auxiliary Switch Cable*	
Wire Color	Function
Red	Adjustable Aux. Switch, Common
Blue	Adjustable Aux. Switch (see Illustration 10)
Black	Adjustable Aux. Switch (see Illustration 10)
Brown**	Fixed Aux. Switch, Common
Orange**	Fixed Aux. Switch, Closed 0–10°
Yellow**	Fixed Aux. Switch, Closed 11–90°

*Left-hand cable, looking from the top (see Illustration 2).
**Fixed auxiliary switches (with brown, yellow, orange wires) are only available in MEP-497x models.

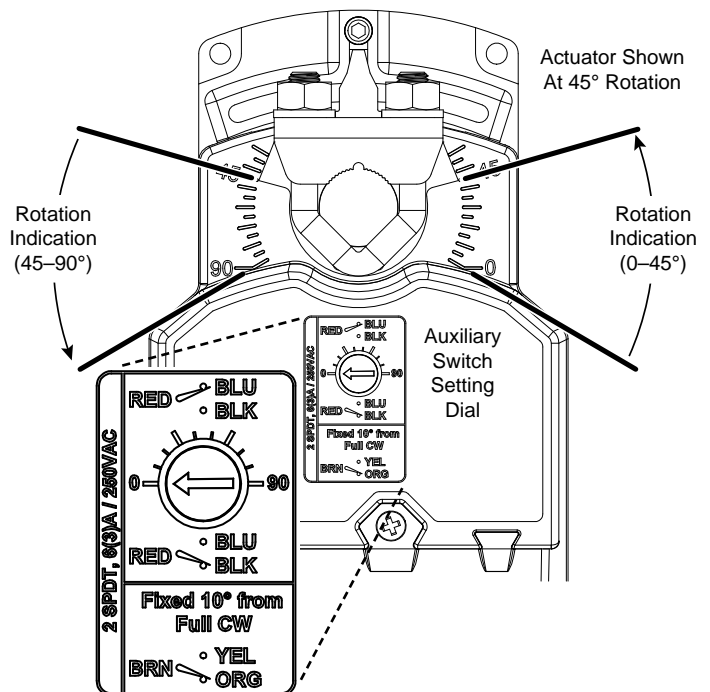

Illustration 10—Actuator Rotation and (MEP-497x) Aux. Switch

Proportional (MEP-4xx2) Models Setup

Proportional actuators are shipped with factory settings of 2–10 VDC input, 1–5 VDC feedback voltage, and CW movement with increasing voltage.

To change any settings, access the selector switches and jumper (see Illustrations 2 and 11) by loosening the screws on the conduit fitting and lifting up to remove the fitting.

1. Select actuator rotation with the **Direction** switch.
2. Use the **Input Range** switch to select either 0–10 or 2–10 for the VDC input range. This also sets the starting point for the feedback voltage range (e.g., 2–10 VDC input provides a corresponding feedback voltage of either 2–10 or 1–5 VDC). Select the desired feedback range with the **Feedback** switch.

Switch	Feedback	Direction*	Input Range
Up	0/1–5 VDC	CCW	2–10 VDC
Down	0/2–10 VDC	CW	0–10 VDC

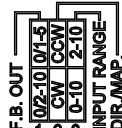

Illustration 11—Feedback/Direction/Mapping Selectors

***NOTE: The Direction Switch has two functions:**

1. **It determines the direction to rotate** (CW or CCW) with increasing voltage and is **factory set in the CW position (down)**. To change, **remove power before flipping the switch up to the CCW position**. Removing power prevents initiation of the auto-mapping feature.
2. **It initiates the auto-mapping feature**. (See description below.) This feature is initiated only by **cycling the switch with power applied** to the unit. The auto-mapping feature will NOT begin if the switch position is changed with power removed or in the event of a power failure.

MEP-4xx2 models also offer a **actuator/signal range reset program (auto-mapping)** feature that reassigns the full 0/2–10 VDC input signal scale over a reduced stroke range for more precise control.

NOTE: The auto-mapping feature works best for ranges that are more than about 45°.

To set the auto-mapping:

1. If desired, use a 7/64-inch hex key wrench to loosen and position the end-stop screw.
2. With power applied to the actuator, flip the Direction switch (from its required CW or CCW increasing voltage direction) to start the reset mode. The actuator will first move to the

CCW limit. The complete reset process will take approximately four minutes.

3. Return the Direction switch to the required increasing voltage direction before the reset finishes. The reset process is complete after the actuator has moved to the CW limit and has begun to position normally.
4. Verify that the actuator travels completely across the new range.

For example, after completing the auto-mapping program, the **new actuator stroke is 0–80°**:

- **With a 0–10 VDC input**, a 5 VDC input signal (halfway between 0–10 VDC) will drive the actuator to the 40° position (50% of its adjusted range) and the feedback voltage will be 2.5 VDC if the Feedback switch is set at the 0–5 VDC position or 5 VDC if the Feedback switch is set at 0–10 VDC.
- **With a 2–10 VDC input**, a 6 VDC input signal (halfway between 2–10 VDC) will drive the actuator to the 40° position (50% of its adjusted range) and the feedback voltage will be 3 VDC if the Feedback switch is set at the 1–5 VDC position or 6 VDC if the Feedback switch is set at 2–10 VDC.

NOTE: After automapping, the feedback range will be equally affected.

Maintenance

No routine maintenance is required. Careful installation enhances long term reliability and performance.

More Information

For models, specifications, and additional information, see the [MEP-4200/4500/4900 Series Data Sheet](#) on the KMC web site.



For accessories, troubleshooting, torque selection, links to sample applications, and other information, see the [MEP-4xxx Applications Guide](#) on the KMC web site.



KMC Controls, Inc.

19476 Industrial Drive, New Paris, IN 46553
574.831.5250

www.kmcccontrols.com; info@kmcccontrols.com