

Part No.	Reference No.	Quantity	Description
75000677#M801UP2~S	*		BLOWER ASSEMBLY
75000676#M801UP2~S	*		BURNER ASSEMBLY
75004163#M801UP2~S	*		GENERAL ASSEMBLY
75007576#M801UP2~S	*		INDUCED BLOWER & FLUE ASSEMBLY
M801UP2_M801UP2_126137~P	*		M801UP2 PARTS LIST
75009819#M801UP2~S	*		MODEL NUMBER NOMENCLATURE

NO GRAPHIC AVAILABLE

75013702

REV
A

**NO
GRAPHIC
AVAILABLE**

Part No.	Reference No.	Quantity	Description
75004163_M801UP2_348684~P	*		GENERAL ASSEMBLY PARTS LIST



Part No.	Reference No.	Quantity	Description
BRK01966	*	2	BRACKET; HEAT EXCHANGER SUPPORT
BRK02173	*	1	BRACKET; INNER BLOWER DOOR DISCONNECT SWITCH
PLT02168	*	1	PLATE; ADAPTER
SCR00968	*	9	SCREW; 10-16 HEX WASHER, TYPE B, THREAD FORMING SCREW, 0.31 THREAD LENGTH, STEEL W/ZINC FINISH
SWT01714	*	1	SWITCH; DOOR SPST, 21 AMP, 125/250VAC
TIE00026	*	1	TIE; CABLE, 8-1/2IN.
TUB08301	*	1	TUBE; PRESSURE SWITCH, STAINLESS STEEL, .025 O.D. .035 WALL THK.
EXC00997	2	1	EXCHANGER; HEAT
COV04434	5	2	COVER; REPL TOP ASM
PNL28838	6	2	PANEL; TOP QW
SPG00309	7	1	SPRING; DOOR RETAINER, INCLUDED IN COVER ASSEMBLY
RIV00071	8	5	RIVET; POP, QTY 100 PER BOX COMPLETE COVER ASSEMBLY WILL INCLUDE THIS
CNL01933	9	1	CHANNEL; BOTTOM DF QW
DOR04086	10	1	DOOR; BURNER
PLT04873	11	1	PLATE; NAME ASM
DOR04079	12	1	DOOR; REPL ASM
DOR01192	13	1	DOOR; FURNACE, CUMBERLAND
BRK02826	15	1	BRACKET; BLOWER DOOR SWITCH
BAF00899	17	1	BAFFLE; HEAT EXCHANGER
BRK01574	20	3	BRACKET; CONNECTION, COIL ATTACHMENT, FOR AIR HANDLER CONNECT.
GRM00836	22	1	GROMMET; WIRE, 2.55 LENGTH X 1.69 WIDTH X .32 THICK
CNT03799	24	1	CONTROL; IFC W/COVER AND WIRE LEADS
TRR01816	25	1	TRANSFORMER;
SUP04110	26	2	SUPPORT; INNER DOOR
DOR02016	27	1	DOOR; INNER BLOWER
SWT01263	30	1	SWITCH; THERMAL LIMIT, OPEN AT 210, CLOSE AT 180 DEG. F
SWT01275	30	1	SWITCH; THERMAL LIMIT, OPEN AT 135, CLOSE AT 105 DEG. F
SHD00194	32	1	SHIELD; LIMIT
BOX01499	33	1	BOX; JUNCTION BOX
COV03320	34	1	COVER; JUNCTION BOX COVER
BUS00300	35	1	BUSHING; STRAIN RELIEF
IRT00020	36	3	INSERT; BURNER
SWT02293	37	1	SWITCH; PRESSURE, 1 POLE, N.O., 1/10 HP, 3 FLA, 18 LRA, 120 VAC, OPEN AT -0.45 TO -0.55 WC, CLOSE AT -0.65 (IS2)
HSE01563	38	1	HOSE; PRESSURE SWITCH, 5.00 X .188 ID X .094 WALL, TRANSLUCENT SILICONE COMPOUND

Induced Blower and Flue Assembly

75007576

REV
A



This is a typical illustration. The unit in the field may not appear exactly as shown.

Part No.	Reference No.	Quantity	Description
75007576_M801UP2_283322~P	*		INDUCED BLOWER & FLUE ASSEMBLY PARTS LIST

Induced Blower and Flue Assembly

75007576

REV
A

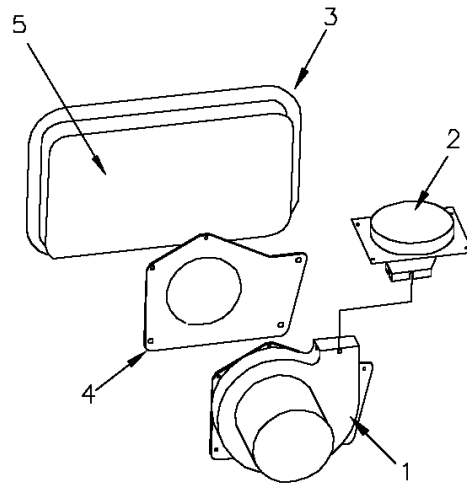

This is a typical illustration. The unit in the field may not appear exactly as shown.

Parts List Number :M801UP2#M801UP2

Model Number :M801P060AD36AAB

Part No.	Reference No.	Quantity	Description
BLW00886	1	1	BLOWER; INDUCED, 1 STAGE
ADP00295	2	1	ADAPTER;FLUE TRANSITION ASSEMBLY
GKT02603	3	1	GASKET;COLLECTOR BOX
GKT03081	4	1	GASKET; VENTER ASSEMBLY
BOX02134	5	1	BOX; FLUE COLLECTOR

Part No.	Reference No.	Quantity	Description
75000676_M801UP2_348683~P	*		BURNER ASSEMBLY PARTS LIST



Part No.	Reference No.	Quantity	Description
COV03389	1	1	COVER; BURNER, 9.10 LG
SUP02127	2	1	SUPPORT; BURNER-RIGHT HAND
VAL09029	3	1	VALVE; GAS, SLOW OPENING 1/2-14 NPT, 24V, 50/60 HZ, "J" SERIES
ORF01427	4	3	ORIFICE; SPUD, DRILL #45, BRASS
MFD00525	5	1	MANIFOLD; ASSEMBLY FOR 3 BURNER
IGN00152	6	1	MIN=12/12 IGNITER; SILICON-NITRIDE, 120V, INCLUDES BRACKET AND SCREWS
BRK03336	7	1	BRACKET; SiNi IGNITOR BRACKET
SEN01114	8	1	SENSOR; FLAME, NIKROTHAL 80 MATERIAL
BRK01527	9	1	BRACKET; BURNER
BNR01074	10	3	BURNER; ALUMINUM STL, .50 INSERT DIA, TOG-L-LOC
SWT02173	11	2	SWITCH; SWITCH-FLAME ROLLOUT
SUP02126	12	1	SUPPORT; BURNER-LEFT HAND
BRK01960	13	1	BRACKET; TOP

Blower Assembly

75000677

REV
A



This is a typical illustration. The unit in the field may not appear exactly as shown.

Part No.	Reference No.	Quantity	Description
75000677_M801UP2_333620~P	*		BLOWER ASSEMBLY PARTS LIST

Blower Assembly

75000677

REV
A



This is a typical illustration. The unit in the field may not appear exactly as shown.

Part No.	Reference No.	Quantity	Description
BLW00533	1	1	BLOWER; REPLACEMENT ASM. W/MOTOR
BLW00734	1	1	BLOWER; REPLACEMENT BLOWER ASSEMBLY
CPT00088	2	1	CAPACITOR; RUN, 10 MFD, 440V OVAL, W/O RESISTOR
CPT00478	2	1	CAPACITOR; RUN, 15 MFD, 370VAC, OVAL, W/O RESISTOR
SRP00841	3	1	STRAP;
HUS01622	5	1	HOUSING;BLOWER
MOT11993	6	1	MOTOR; 1/2 HP, 115/60/1, 1075 RPM, 4SPEED, TYPE PSC, 48 FRAME, CCW, SLEEVE BEARING, 10 MFD @ 370V, INCLUDES RESILIENT RINGS
RNG00957	7	2	RING; RESILIENT, 2.5 OD
BRK00690	8	1	BRACKET; ASSEMBLY, SHORT, 4.06 X 2.31, INCLUDES RING CUP
BRK00691	8	1	BRACKET; ASSEMBLY, LONG, 5.00 X 2.39, INCLUDES RING CUP
SUP03399	9	3	SUPPORT; HANGER
WHL01171	10	1	WHEEL;BLOWER,11IN.DIA X 7IN.WIDTH,.50IN.BORE, CONVEX, CW
WHL02353	10	1	WHEEL; BLOWER, 48 BLADES, CW, CONCAVE DISC, 10 X 7
SWT01656	11	1	SWITCH; REVERSE FLOW, OPEN 130F, CLOSE 120F

MODEL NOMENCLATURE
 Montana Furnaces

75009819

REV
 A

Model Number Example
M 9 5 1 P 0 4 0 B D 2 4 A A A
1 2 3 4 5 6 7 8 9 10 11 12 13 14 15

Digit 1 = Brand
 M = Montana

Digit 2,3 = Model Family
 80 = Non Condensing
 90 or 95 = Condensing

Digit 4 = Gas Valve Stages
 1 = Single Stage
 2 = Two Stage
 3 = Three Stage
 M = Modulating

Digit 5 = Blower Type
 P = PSC
 X - X13
 V - Variable Speed

Digit 6,7,8 = BTU Input Capacity
 040 = 40,000 Btu/h
 060 = 60,000 Btu/h
 065 = 65,000 Btu/h
 080 = 80,000 Btu/h
 100 = 100,000 Btu/h
 110 = 110,000 Btu/h
 120 = 120,000 Btu/h
 140 = 140,000 Btu/h

Digit 9 = Cabinet Width
 A = 14.5" Cabinet Width
 B = 17.5" Cabinet Width
 C = 21.0" Cabinet Width
 D = 24.5" Cabinet Width

Digit 10 = Orientation
 D = Downflow
 U = Upflow

Digit 11,12 = Airflow
 24 = 24,000
 36 = 36,000
 42 = 42,000
 45 = 45,000
 48 = 48,000
 60 = 60,000

Digit 13 = Major Design Change
 A = Major Design Change

Digit 14 = Minor Design Sequence
 A = First Design Sequence
 B = Second Design Sequence
 C = Third Design Sequence

Digit 15 = Service Digit
 A = Service Digit

Part No.	Reference No.	Quantity	Description
75009819_M801UP2_126159~P	*		MODEL NUMBER NOMENCLATURE PARTS LIST

MODEL NOMENCLATURE Montana Furnaces	75009819	REV A
Model Number Example M 9 5 1 P 0 4 0 B D 2 4 A A A 1 2 3 4 5 6 7 8 9 10 11 12 13 14 15		
Digit 1 = Brand M = Montana Digit 2,3 = Model Family 80 = Non Condensing 90 or 95 = Condensing Digit 4 = Gas Valve Stages 1 = Single Stage 2 = Two Stage 3 = Three Stage M = Modulating Digit 5 = Blower Type P = PSC X - X13 V - Variable Speed Digit 6,7,8 = BTU Input Capacity 040 = 40,000 Btu/h 060 = 60,000 Btu/h 065 = 65,000 Btu/h 080 = 80,000 Btu/h 100 = 100,000 Btu/h 110 = 110,000 Btu/h 120 = 120,000 Btu/h 140 = 140,000 Btu/h	Digit 9 = Cabinet Width A = 14.5' Cabinet Width B = 17.5' Cabinet Width C = 21.0' Cabinet Width D = 24.5' Cabinet Width Digit 10 = Orientation D = Downflow U = Upflow Digit 11,12 = Airflow 24 = 24,000 36 = 36,000 42 = 42,000 45 = 45,000 48 = 48,000 60 = 60,000 Digit 13 = Major Design Change A = Major Design Change Digit 14 = Minor Design Sequence A = First Design Sequence B = Second Design Sequence C = Third Design Sequence Digit 15 = Service Digit A = Service Digit	

Parts List Number :M801UP2#M801UP2

Model Number :M801P060AD36AAB