

CREST[®]

CONDENSING BOILER

Outdoor Crest Supplemental Manual Models: OF 751 - 6001



2000549955



WARNING

This manual must only be used by a qualified heating installer / service technician. Read all instructions, including this manual along with the Crest Installation and Operation Manual, and the Crest Service Manual, before installing. Perform steps in the order given. Failure to comply could result in severe personal injury, death, or substantial property damage.

Save this manual for future reference.

CONTENTS

HAZARD DEFINITIONS	2	Fill Water	15
PLEASE READ BEFORE PROCEEDING	3	Boiler Water.....	15
THE OUTDOOR CREST -- HOW IT WORKS	4-5	Oxygen Prevention	16
RATINGS	6	Check for Gas Leaks	16
1. DETERMINE BOILER LOCATION		Check Thermostat Circuit(s)	17
Installation Must Comply With:.....	7	Inspect Condensate System	17
Before Locating the Boiler, Check:	7	Final Checks Before Starting the Boiler.....	17
Provide Clearances.....	8	Start the Boiler	17
Prevent Combustion Air Contamination.....	8	If Boiler Does Not Start Correctly.....	17
Remove Boiler from Wood Pallet.....	8	Check System and Boiler.....	17
Install Outdoor Vent Kit	9	Check Flame and Combustion.....	18
Outdoor Venting	10	Operating Instructions	19
Outdoor Vent/Air Inlet Location	10	4. DIAGRAMS	
2. GAS CONNECTIONS		Ladder Diagram 751 - 2001 Models	20
Gas Supply.....	11	Wiring Diagram 751 - 2001 Models	21
Connecting Gas Supply Piping	11-12	Ladder Diagram 2501 - 3501 Models	22
Natural Gas:	12	Wiring Diagram 2501 - 3501 Models	23
Propane Gas:	12	Ladder Diagram 4001 - 5001 Models	24
Check Inlet Gas Supply	13-14	Wiring Diagram 4001 - 5001 Models	25
Gas Valve Replacement	14	Ladder Diagram 6001 Model	26
3. START-UP		Wiring Diagram 6001 Model	27
Pre-Commissioning Cleaning.....	15	Revision Notes	Back Cover

Hazard definitions

The following defined terms are used throughout this manual to bring attention to the presence of hazards of various risk levels or to important information concerning the life of the product.

DANGER

DANGER indicates an imminently hazardous situation which, if not avoided, will result in death or serious injury.

WARNING

WARNING indicates a potentially hazardous situation which, if not avoided, could result in death or serious injury.

CAUTION

CAUTION indicates a potentially hazardous situation which, if not avoided, may result in minor or moderate injury.

CAUTION

CAUTION used without the safety alert symbol indicates a potentially hazardous situation which, if not avoided, may result in property damage.

NOTICE

NOTICE indicates special instructions on installation, operation, or maintenance that are important but not related to personal injury or property damage.

Please read before proceeding

WARNING

Installer – Read all instructions, including this manual, the Crest Installation and Operation Manual and the Crest Service Manual, before installing. Perform steps in the order given.

User – This manual is for use only by a qualified heating installer/service technician. Refer to the User’s Information Manual for your reference.

Have this boiler serviced/inspected by a qualified service technician, at least annually.

Failure to comply with the above could result in severe personal injury, death or substantial property damage.

NOTICE

When calling or writing about the boiler – Please have the boiler model and serial number from the boiler rating plate.

Consider piping and installation when determining boiler location.

Any claims for damage or shortage in shipment must be filed immediately against the transportation company by the consignee.

Factory warranty (shipped with unit) does not apply to units improperly installed or improperly operated.

WARNING

Failure to adhere to the guidelines on this page can result in severe personal injury, death, or substantial property damage.

WARNING

If the information in this manual is not followed exactly, a fire or explosion may result causing property damage, personal injury or loss of life.

This appliance **MUST NOT** be installed in any location where gasoline or flammable vapors are likely to be present.

WHAT TO DO IF YOU SMELL GAS

- Do not try to light any appliance.
- Do not touch any electric switch; do not use any phone in your building.
- Immediately call your gas supplier from a near by phone. Follow the gas supplier’s instructions.
- If you cannot reach your gas supplier, call the fire department.
- Installation and service must be performed by a qualified installer, service agency, or the gas supplier.

When servicing boiler –

- To avoid electric shock, disconnect electrical supply before performing maintenance.
- To avoid severe burns, allow boiler to cool before performing maintenance.

Boiler operation –

- Do not block flow of combustion or ventilation air to the boiler.
- Should overheating occur or gas supply fail to shut off, do not turn off or disconnect electrical supply to circulator. Instead, shut off the gas supply at a location external to the appliance.
- Do not use this boiler if any part has been under water. The possible damage to a flooded appliance can be extensive and present numerous safety hazards. Any appliance that has been under water must be replaced.
- The installer must verify that at least one carbon monoxide alarm has been installed within a residential living space or home following the alarm manufacturer’s instructions and applicable local codes before putting the appliance into operation.

The Outdoor Crest - How it works...

1. **Front access panels**
Provides access to the controls compartment.
2. **Top access panel**
Provides access to the burner compartment.
3. **Optional outdoor air inlet hood assembly** (shipped separately with outdoor installation kits)
The hood assembly is required when installing outdoors for combustion air to prevent rain and debris from entering the air inlet.
4. **Boiler drain connection**
Location from which the heat exchanger can be drained.
5. **Condensate drain connection**
The condensate drain connection provides a connection point to install a condensate drain line using flexible hose provided.
6. **Condensate trap box (shipped separately with outdoor installation kits)**
The condensate trap box comes assembled inside the outdoor installation kit. The condensate trap box is required for outdoor installations to protect/house the condensate trap.
7. **Control module (on control panel assembly)**
The control module responds to internal and external signals and controls the blower, gas valves, and pump(s), depending on the application, to meet the heating demand.
8. **Electronic display**
Digital controls with SMART TOUCH screen technology, full color display, and an 8" user interface screen.
9. **Gas connection pipe**
The gas connection pipe is a threaded black iron pipe connection (see Gas Connections Section for specific model pipe size requirements). This pipe should be connected to the incoming gas supply to deliver gas to the boiler.
10. **Gas shutoff valve (inside unit)**
The manual gas shutoff valve is used to isolate the boiler gas train from the gas supply.
11. **Gas valves**
The gas valves sense the negative pressure created by the blower, allowing gas to flow only if the gas valves are powered and combustion air is flowing.
12. **Condensate trap**
The condensate trap is sized for a 1" PVC outlet connection pipe.
13. **Line voltage junction box**
The line voltage junction box contains the connection points for the line voltage power to the boiler (and pumps if used).
14. **Line voltage wiring connections**
Conduit connection points for the high voltage junction box.
15. **Low gas pressure switch**
Monitors gas supply pressure to the boiler and shuts the boiler down in the event a low gas pressure condition occurs.
16. **High gas pressure switch**
Monitors gas supply pressure to the boiler and shuts the boiler down in the event a high gas pressure condition occurs.
17. **Low voltage connection board(s)**
Connection boards used to connect external low voltage devices.
18. **Low voltage wiring connections (knockouts)**
Conduit connection points for the low voltage connection boards.
19. **Power switch**
The On/Off power switch provides the ability to turn line voltage power to the boiler on and off.
20. **Relief valve**
The safety relief valve protects the heat exchanger from an over pressure condition. The boiler comes with a 50 PSI relief valve as standard equipment. Optional settings are available.
21. **Reset switch**
Reset switch for the low water cutoff. Hold the switch for 10 seconds to reset.
22. **Test switch**
The test switch permits manual triggering of the LWCO safety circuit to test the contacts and evaluate the integrity of the circuit. Hold the switch for 10 seconds to test.
23. **Firetube heat exchanger**
High grade stainless steel WAVE™ firetube design that extracts heat from flue gases and transfers it directly into boiler water.
24. **Temperature and pressure gauge**
Monitors the outlet temperature of the boiler as well as the system water pressure.
25. **Venturi (not shown)**
The venturi controls air and gas flow into the burner.
26. **Water inlet**
An ANSI flange connects the return water from the system to the heat exchanger.
27. **Water outlet**
An ANSI flange connects the hot water supply from the boiler to the system.
28. **Flame inspection window (not shown)**
Two large high temperature quartz observation windows provide views of the burner surface during firing.
29. **Air metering valve**
The air metering valve is used to control the amount of air used when firing.
30. **Air metering valve air pressure switch**
The air metering valve air pressure switch is used to ensure the air metering valve is open when firing gas valve 2.
31. **Vent support (shipped in the ship loose parts box with each unit)**
The vent support is required for outdoor installations to support the vent piping.
32. **Air pressure switch**
The air pressure switch detects blocked flue/vent conditions.
33. **O2 Sensor (not shown?)**
The O2 sensor is used to measure the unburned oxygen in the exhaust gas to determine a rich or lean fuel mixture.

The Outdoor Crest - How it works... *(continued)*

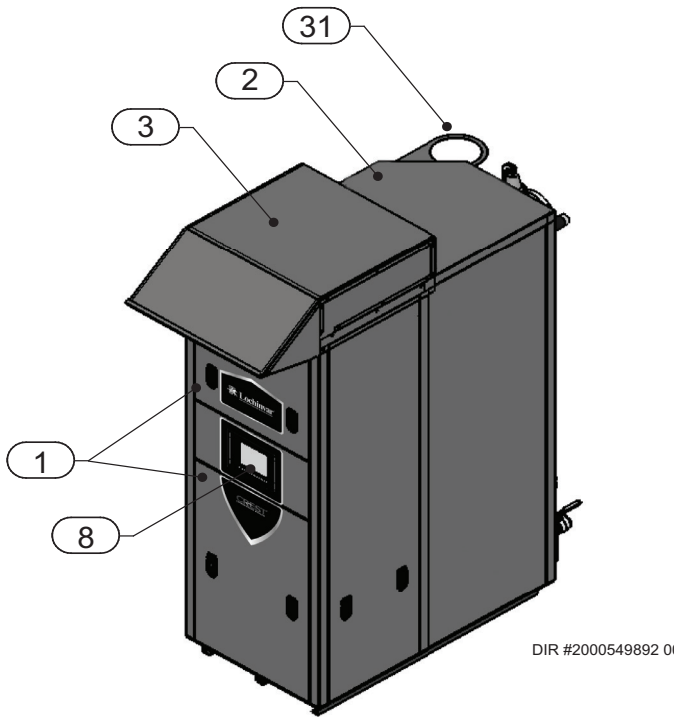

DIR #2000549892 01

Front View

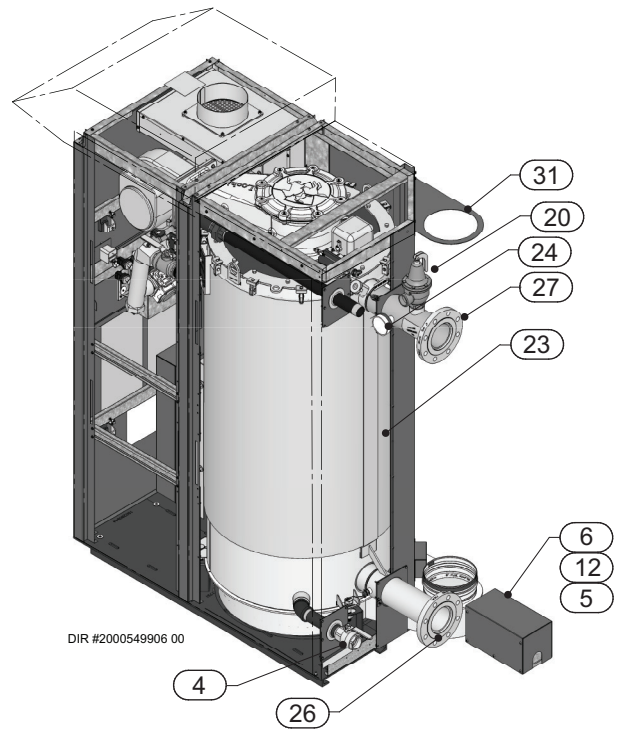

DIR #2000549906 00

Rear View

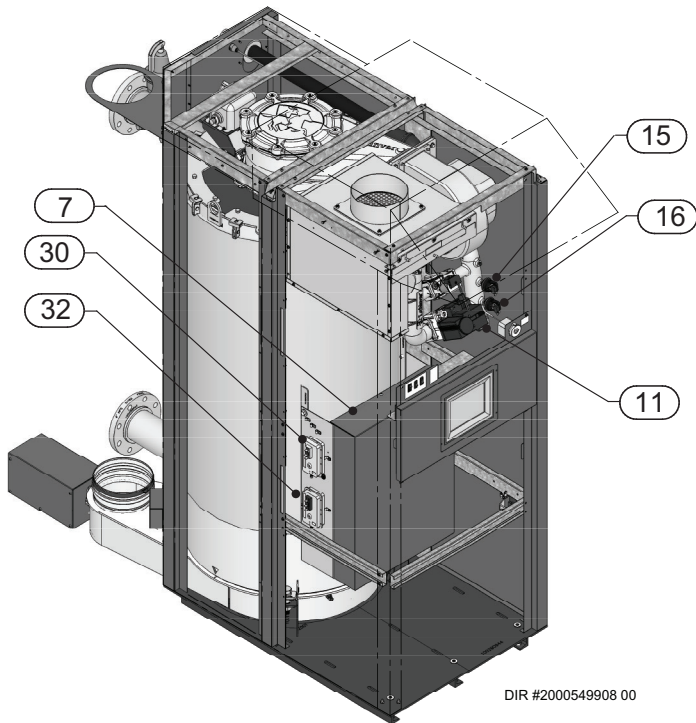

DIR #2000549908 00

Left Side (inside unit)

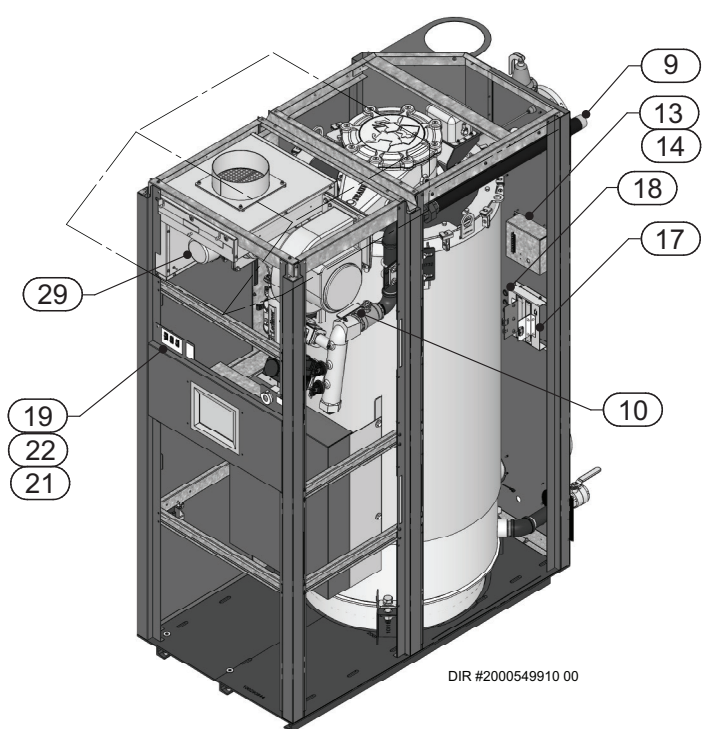

DIR #2000549910 00

Right Side (inside unit)

Ratings



DOE

 Outdoor Crest AHRI Rating				
Model Number Note: Change "N" to "L" for L.P. gas models.	Input MBH (Notes 4 - 8)		Gross Output MBH (Note 1)	Net AHRI Ratings Water, MBH (Note 2)
	Min	Max		
OF(N,L)0751	50	750	722	626
OF(N,L)1001	50	999	961	834
OF(N,L)1251	62.5	1250	1203	1043
OF(N,L)1501	60	1500	1443	1252
OF(N,L)1751	70	1750	1684	1461
OF(N,L)2001	80	1999	1923	1699
OF(N,L)2501	125	2500	2400	2087
OF(N,L)3001	150	3000	2883	2507
OF(N,L)3501	175	3500	3364	2925
OF(N,L)4001	333.3	3999	3843	3342
OF(N,L)5001	499.9	4999	4804	4177
OF(N,L)6001	600	6000	5766	5014

Other Specifications		
Boiler Water Content Gallons	Water Connections	Gas Connections
73	3"	1 1/4"
77	3"	1 1/4"
87	3"	1 1/2"
94	4"	1 1/2"
106	4"	1 1/2"
111	4"	1 1/2"
157	4"	2"
156	4"	2"
202	4"	2"
201	4"	2 1/2"
254	6"	2 1/2"
304	6"	3"

NOTICE Maximum allowed working pressure is located on the rating plate.

Notes:

1. The ratings are based on standard test procedures prescribed by the United States Department of Energy.
2. Net AHRI ratings are based on net installed radiation of sufficient quantity for the requirements of the building and nothing need be added for normal piping and pickup. Ratings are based on a piping and pickup allowance of 1.15.
3. Standard Outdoor Crest boilers are equipped to operate from sea level to 4,500 feet **only**. The boiler will de-rate by 1.4% for each 1,000 feet above sea level up to 4,500 feet.
4. Ratings have been confirmed by the Hydronics Section of AHRI.
5. Outdoor Crest boilers comply with the requirements of CSD-1 Section CW-400 requirements as a temperature operation control. The manual reset high limit provided with the Outdoor Crest is listed to UL353.

1 Determine boiler location

Installation must comply with:

- Local, state, provincial, and national codes, laws, regulations, and ordinances.
- National Fuel Gas Code, ANSI Z223.1 – latest edition.
- Standard for Controls and Safety Devices for Automatically Fired Boilers, ANSI/ASME CSD-1, when required.
- National Electrical Code.

NOTICE The Outdoor Crest gas manifold and controls met safe lighting and other performance criteria when the boiler underwent tests specified in ANSI Z21.13 – latest edition.

WARNING Outdoor models must be installed outdoors only and must use the outdoor air inlet hood assembly along with the vent termination cap supplied by the manufacturer. Personal injury or product damage may result if any other venting is used or if an outdoor model is used indoors. All covers, doors and jacket panels must be properly installed to ensure proper operation and prevent a hazardous condition.

WARNING This product contains a condensate management and disposal system that may be subject to freezing if exposed to sustained temperatures below 32°F. Precautions should be taken to protect the condensate trap and drain lines during extended periods of outdoor temperatures below 32°F.

WARNING The Outdoor Crest is NOT suitable for installation in areas which may experience temperatures below 32°F.

Before locating the boiler, check:

1. Check for nearby connection to:
 - System water piping
 - Gas supply piping
 - Electrical power
2. - Keep venting areas free of obstructions.
 - Keep area clean and free of combustible and flammable materials.
 - To avoid a blocked air inlet or blocked flue condition, keep the outdoor air inlet and flue outlet clear of leaves, debris, etc.

CAUTION Do not install outdoor models directly on the ground. You must install the outdoor unit on a level concrete, brick, block, or pressure-treated wood platform.

CAUTION Do not locate unit so that high winds can deflect off of adjacent walls, buildings or shrubbery causing recirculation. Recirculation of flue products may cause operational problems, bad combustion or damage to controls. Locate unit at least 3 feet (0.91m) from any wall or vertical surface to prevent wind conditions from affecting performance.

CAUTION The unit must not be installed in an area that is enclosed by walls or a fence that will block free wind movement around the appliance. Free movement of wind around the outdoor unit is required to carry away the flue products and provide combustion air. The flue outlet/ combustion air inlet of an outdoor unit must not be installed closer than 10 feet from an inside corner of an L-shaped structure. Walls or enclosed fencing may cause eddy currents which can recirculate the flue products into the combustion air inlet. Recirculation of flue products may cause operational problems, bad combustion or non-warrantable damage to controls.

Locate the unit at least 3 feet (0.91m) outside any overhang.

CAUTION Do not install in locations where rain from building runoff drains will spill onto the unit.

Do not locate the unit so that water from sprinklers may spray directly onto it. Water may damage controls or other electrical components.

WARNING Do not install the unit under a deck. Do not install the unit in a well, stairwell, alcove, courtyard or other recessed area.

Do not install outdoor units on stack frames. Failure to comply with the above may result in severe personal injury, death or substantial property damage.

3. Check area around the boiler. Remove any combustible materials, gasoline and other flammable liquids.

WARNING Failure to keep boiler area clear and free of combustible materials, gasoline, and other flammable liquids and vapors can result in severe personal injury, death, or substantial property damage.

4. If a new boiler will replace an existing boiler, check for and correct system problems, such as:
 - System leaks causing oxygen corrosion or heat exchanger cracks from hard water deposits.
 - Incorrectly-sized expansion tank.
 - Debris left from existing piping, if not flushed and cleaned with an appropriate cleaner.

1 Determine boiler location

- This unit is not intended for installations where temperatures may reach below 32°F (0°C). Exposure to freezing temperatures will cause the system and boiler to freeze and leak.
5. Check around the boiler for any potential air contaminants that could risk corrosion to the boiler or the boiler combustion air supply (see Table 1A). Prevent combustion air contamination. Remove any of these contaminants from the boiler area.

WARNING DO NOT install units in areas that contain corrosive contaminants (see Table 1A). Failure to comply could result in severe personal injury, death, or substantial property damage.

Provide clearances:

Clearances from combustible materials

1. Hot water pipes—at least 1/4" (6 mm) from combustible materials.
2. Jacket—minimum of 0" from right side and 14" from rear side for proximity from combustible materials.
3. Vent—minimum of 1" from combustible materials.

Clearances for service access

1. If you do not provide the minimum clearances shown, it may not be possible to service the boiler without removing it from the space.

Recommended service clearances

Front: 30" (762mm)
 Top: 24" (610mm)
 Left side: 24" (610mm)
 Right side: 24" (610mm)
 Rear: 24" (610mm)

Flooring and foundation

Flooring

The Outdoor Crest is approved for installation on combustible flooring.

Under no circumstances is the manufacturer to be held responsible for water damage in connection with this appliance, or any of its components. If flooding is possible, elevate the boiler sufficiently to prevent water from reaching the boiler.

Prevent combustion air contamination

Do not install unit in locations that can allow contamination of combustion air. Refer to Table 1A for products and areas which may cause contaminated combustion air.

Table 1A Corrosive Contaminants and Sources

Products to avoid:
Spray cans containing chloro/fluorocarbons
Permanent wave solutions
Chlorinated waxes/cleaners
Chlorine-based swimming pool chemicals
Calcium chloride used for thawing
Sodium chloride used for water softening
Refrigerant leaks
Paint or varnish removers
Hydrochloric acid/muriatic acid
Cements and glues
Antistatic fabric softeners used in clothes dryers
Chlorine-type bleaches, detergents, and cleaning solvents found in household laundry rooms
Adhesives used to fasten building products and other similar products
Areas likely to have contaminants
Dry cleaning/laundry areas and establishments
Swimming pools
Metal fabrication plants
Beauty shops
Refrigeration repair shops
Photo processing plants
Auto body shops
Plastic manufacturing plants
Furniture refinishing areas and establishments
New building construction
Remodeling areas
Garages with workshops

Remove boiler from wood pallet

1. After removing the outer shipping crate and plastic from the boiler, remove the parts package (packaged parts inside the controls compartment of the boiler inside the lower front access panel).
2. To remove the boiler from the pallet:
 - a. Remove the three (3) shipping bolts located inside the controls compartment securing the boiler to the front of the pallet (see FIG. 1-1 on page 9).
 - b. Remove the three (3) shipping bolts that fasten the tie-down brackets securing the legs to the rear of the pallet (FIG. 1-1).
 - c. The boiler can now be removed from the pallet using a lift truck lifting from the front or rear of the boiler. If lifting from the front, the lift truck forks must extend at least half way under the boiler heat exchanger to assure proper lifting technique with no damage to the boiler.

1 Determine boiler location *(continued)*

WARNING Failure to assure the truck forks are long enough to extend at least halfway under the boiler heat exchanger will result in the boiler tipping off the lift truck, and potentially falling. This will result in severe personal injury, death, or substantial property damage.

- d. If lifting by crane is desired, remove the top access panels to gain access to the lifting lugs located on the boiler. It is also recommended that the upper and lower front panels along with both front side panels be removed (no tools required).

Note: Reapply silicone sealant as necessary when placing the access panels back on the unit.

NOTICE Do not drop the boiler or bump the jacket on the floor or pallet. Damage to the boiler can result.

- 8. Once the condensate hoses are inserted through the terminal plates of the condensate trap box and attached to the condensate trap (both inlet and vent), the condensate trap box can then be re-assembled (FIG. 1-3).
- 9. Make certain the condensate trap is oriented correctly and that the wiring harness has enough slack to ensure the escutcheons remain seated properly. For proper trap placement, reference the Condensate Disposal Section of the Crest Installation and Operation Manual.

Figure 1-2 Install the Air Inlet Hood Assembly

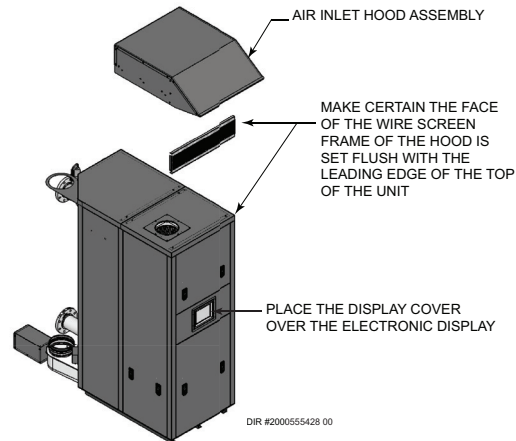

CAUTION Do NOT use grease or other lubricant on the vent seals. Only water may be used for this purpose. Grease or other lubricant can make the seal brittle or cause tearing of the seal surface which can result in flue gas leakage.

Figure 1-1 Boiler Mounted on Shipping Pallet

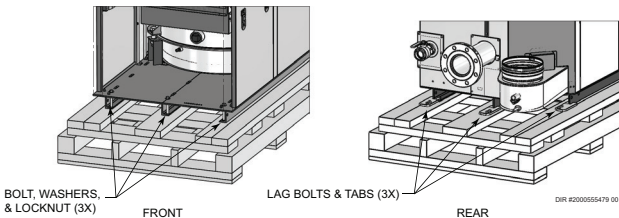

Install outdoor kit

In order to properly install the appliance in an outdoor configuration, the optional outdoor kit must be used (see Table 1B).

1. Locate all components from the installation kit and carton.
 - a. Kit Components: Air Inlet Hood Assembly, Condensate Trap Box Assembly, and Display Cover.
2. Position the air inlet hood assembly to the top of the unit. Make certain the face of the wire screen frame of the hood is set flush with the front leading edge of the top of the unit as shown in FIG. 1-2.
3. Once positioned, use the kit provided self-tapping fasteners to attach the hood to the unit through the holes in the sides of the air inlet hood assembly.

Note: Once the air inlet hood is installed, the top, front and side doors are still removable.

4. Locate the kit provided display cover and place over the electronic display (FIG. 1-2).
5. Locate the kit provided condensate trap box.
6. The outdoor condensate wiring harness has escutcheons built into it which allows a water tight fit into both the rear jacket of the boiler as well as the terminal plates of the condensate trap box. Connect the outdoor condensate wiring harness to the pigtail connector of the condensate trap (see FIG. 1-3).
7. Disassemble the condensate trap box.

Figure 1-3 Disassemble/Re-assemble outdoor condensate trap

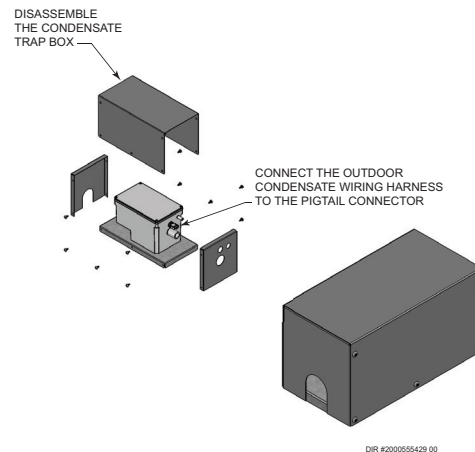

Table 1B Outdoor Vent Kits

Model	Outdoor Kit Number
751 - 2001	100301827
2501 - 3001	100313289
3501	100308477
4001 - 5001	100313290
6001	100313291

1 Determine boiler location

Outdoor venting

- Vent materials for outdoor venting are to be field supplied.
- The vent must terminate at least 36 inches above the top of the unit.
- All vent materials must be supported as recommended by the vent manufacturer.

NOTICE

Before installing a venting system, follow all requirements found in the Outdoor Venting section of this manual.

Units are self-venting and can be used outdoors when installed with the optional outdoor kit.

WARNING

Only install outdoor models outdoors, and only use the vent caps specified in this manual. Personal injury or product damage may result if any other cap is used, or if an indoor model is used outdoors. Properly install all covers, doors, and jacket panels to ensure proper operation and prevent a hazardous condition.

Combustion air supply must be free of contaminants To prevent recirculation of the flue products into the combustion air inlet, follow all instructions in this section.

For outdoor models, you must install a flue termination. Do not install outdoor models directly on the ground. You must install the outdoor unit on a concrete, brick, block, or other non-combustible pad.

Outdoor vent / air inlet location

Keep venting areas free of obstructions. Keep area clean and free of combustible and flammable materials. Maintain minimum clearances to combustibles as stated in this manual.

WARNING

DO NOT install units in areas that contain corrosive contaminants (see Table 1A on page 8). Failure to comply could result in severe personal injury, death, or substantial property damage.

Keep venting areas free of obstructions. Keep area clean and free of combustible and flammable materials. Maintain minimum clearances to combustible surfaces and a 36" (915 mm) minimum clearance to the air inlet. To avoid a blocked air inlet or blocked flue condition, keep the air inlet, flue outlet, and condensate trap clear of leaves, debris, etc.

Do not locate unit so that high winds can deflect off of adjacent walls, buildings, or shrubbery causing recirculation. Recirculation of flue products may cause operational problems, bad combustion, or damage to controls.

Locate outdoor cap at least 48" (1.22 m) below and 48" (1.22 m) horizontally from any window, door, walkway, or gravity air intake.

Locate unit at least 10 feet (3.05 m) away from any forced air inlet.

Locate unit at least 3 feet (0.91 m) outside any overhang.

Clearances around outdoor installations can change with time. Do not allow the growth of trees, shrubs, or other plants to obstruct the proper operation of the outdoor vent system.

Do not install in locations where rain from building runoff drains will spill onto the unit.

Some discoloration to exterior building or unit surfaces can be expected. Adjacent brick or masonry surfaces should be protected with a rust resistant sheet metal plate.

2 Gas connections

Gas supply

NOTICE Ensure that the high gas pressure regulator is at least 10 feet (3 m) upstream of the appliance.

NOTICE The gas inlet size has been designed to allow the minimum of 10 feet between the boiler and regulator and for a maximum pressure drop of 1" w.c.

1. It is recommended to install one (1) gas regulator for each Outdoor Crest boiler.
2. Gas regulators should be installed in a horizontal orientation unless otherwise recommended by the regulator manufacturer.
3. It is recommended to install a filter at the inlet of a gas regulator to prevent debris from entering the regulator.
4. Gas regulators should be installed the greater of either 20 inches or 10 pipe diameters from the nearest fitting, elbow, or valve to the outlet of the regulator.
5. It is recommended that the gas regulator outlet size match the gas inlet size of the boiler and to not change the pipe size between them. If the pipe diameter must be increased, a bell reducer type fitting should be located at the regulator outlet and the boiler inlet, maintaining the distance indicated in Step 4.
6. Gas regulators must be properly vented to ensure proper function:
 - a. Vent pipe must be no smaller than the regulator vent connection size.
 - b. Each regulator must have a separate vent line.
 - c. Vent lines must not be combined together or with any other equipment that also requires atmospheric vents.
 - d. Excessive gas regulator vent length will detrimentally affect regulator performance:
 - Gas regulators must be properly vented according to the regulator manufacturer's instructions.
 - It is recommended that regulator vent length not exceed 15 equivalent feet (4.5 m).
 - When regulator vent must exceed 15 equivalent feet, it is recommended to use a ventless regulator equipped with a vent limiter.
 - If a ventless regulator cannot be utilized, it is recommended to increase vent diameter by one pipe size after the initial 15 equivalent feet and every additional 10 equivalent feet.
 - e. Proper measures must be taken to prevent water, snow, insects, or other debris from obstructing the vent.

Connecting gas supply piping

1. Refer to FIG. 2-1 to pipe gas to the boiler.
 - a. Install ground joint union for servicing, when required.

Figure 2-1 Gas Supply Piping

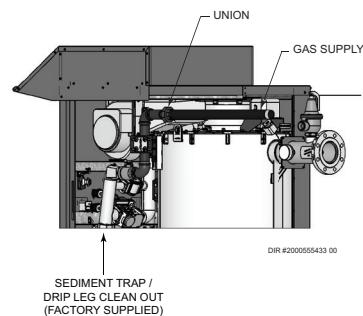

2. Support piping with hangers, not by the boiler or its accessories.

WARNING The gas valve and blower will not support the weight of the piping. Do not attempt to support the weight of the piping with the boiler or its accessories. Failure to comply could result in severe personal injury, death, or substantial property damage.

3. Purge all air from the gas supply piping.
4. Before placing the boiler in operation, check the boiler and its gas connection for leaks.
 - a. The appliance must be disconnected from the gas supply piping system during any pressure testing of that system at a test pressure in excess of 1/2 PSIG (3.5 kPa).
 - b. The appliance must be isolated from the gas supply piping system by closing a manual shutoff valve during any pressure testing of the gas supply piping system at test pressures equal to or less than 1/2 PSIG (3.5 kPa).
 - c. The appliance and its gas connection must be leak tested before placing it in operation.

WARNING Do not check for gas leaks with an open flame – use the bubble test. Failure to use the bubble test or check for gas leaks can cause severe personal injury, death, or substantial property damage.

5. Use pipe sealing compound compatible with propane gases. Apply sparingly only to male threads of the pipe joints so that pipe dope does not block gas flow.

WARNING Failure to apply pipe sealing compound as detailed in the Crest Installation and Operation Manual can result in severe personal injury, death, or substantial property damage.

Table 2A Gas Inlet Size

Model	Gas Inlet Size
OF0751 - OF1001	1 1/4"
OF1251 - OF2001	1 1/2"
OF2501 - OF3501	2"
OF4001 - OF5001	2 1/2"
OF6001	3"

2 Gas connections

WARNING Use two wrenches when tightening gas piping at boiler (FIG. 2-2), using one wrench to prevent the boiler gas line connection from turning. Failure to support the boiler gas connection pipe to prevent it from turning could damage gas line components.

Figure 2-2 Inlet Pipe with Backup Wrench

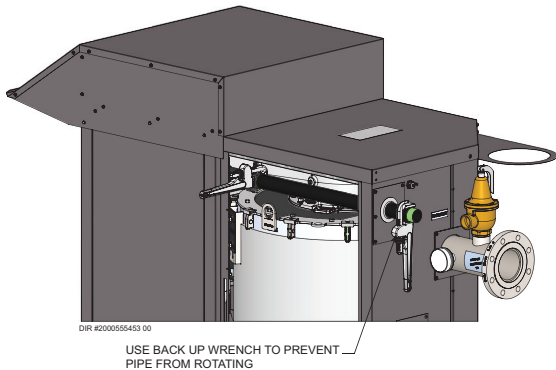

NOTICE Maximum inlet gas pressure must not exceed the value specified. Minimum value listed is for the purposes of input adjustment.

Natural gas:

WARNING Check boiler rating plate to determine which fuel the boiler is set for. Outdoor Crest boilers CANNOT be field converted. Failure to comply could result in severe personal injury, death, or substantial property damage.

Pipe sizing for natural gas

1. Refer to Table 2B for pipe length and diameter. Based on rated boiler input (divide by 1,000 to obtain cubic feet per hour).
 - a. Table 2B is only for natural gas with specific gravity 0.60, with a pressure drop through the gas piping of 0.3 inches w.c.
 - b. For additional gas pipe sizing information, refer to the National Fuel Gas Code, NFPA 54 / ANSI Z223.1 - latest edition, or in Canada CSA B149.1 Installation Code.

Natural gas supply pressure requirements

1. Target a supply pressure of 7 inches w.c. (1.7 kPa) measured when the boiler is operating at minimum input rate. Gas pressure can be adjusted higher or lower than 7 inches w.c. as needed.
2. Pressure required at the gas valve inlet pressure port:
 - Maximum 14 inches w.c. (3.5 kPa) with boiler operating.
 - Minimum 4 inches w.c. (.99 kPa) with boiler operating.

3. Install 100% lockup gas pressure regulator in supply line for each boiler if inlet pressure exceeds 14 inches w.c. (3.5 kPa).
4. Gas valves used on Outdoor Crest boilers are rated for at least 27 inches w.c. (6.7 kPa).

Propane Gas:

WARNING Check boiler rating plate to determine which fuel the boiler is set for. Outdoor Crest boilers CAN NOT be field converted. Failure to comply could result in severe personal injury, death, or substantial property damage.

Pipe sizing for propane gas

1. Contact gas supplier to size pipes, tanks, and 100% lockup gas pressure regulator.

Propane Supply Pressure Requirements

1. Target a supply pressure of 11 inches w.c. (2.7 kPa) measured when the boiler is operating at minimum input rate. Gas pressure can be adjusted higher or lower than 11 inches w.c. as needed.
2. Adjust propane supply regulator provided by the gas supplier for 14 inches w.c. (3.5 kPa) maximum pressure.
3. Pressure required at gas valve inlet pressure port:
 - Maximum 14 inches w.c. (3.5 kPa) with boiler operating.
 - Minimum 8 inches w.c. (.99 kPa) with boiler operating.

Figure 2-3 Gas Supply Piping to Regulator

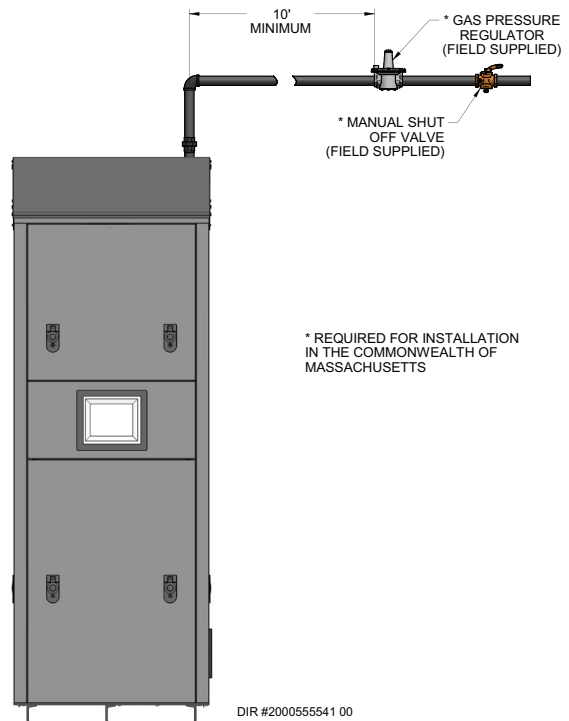

2 Gas connections *(continued)*

Table 2B Natural Gas Pipe Size Chart

TABLE - 2B Capacity of Schedule 40 Metallic Pipe in Cubic Feet of Natural Gas Per Hour (based on .60 specific gravity, 0.30" w.c. pressure drop)														
Pipe Size (Inches)	Length of Pipe in Straight Feet													
	10	20	30	40	50	60	70	80	90	100	125	150	175	200
1 1/4	1,060	726	583	499	442	400	368	343	322	304	269	244	224	209
1 1/2	1,580	1,090	873	747	662	600	552	514	482	455	403	366	336	313
2	3,050	2,090	1,680	1,440	1,280	1,160	1,060	989	928	877	777	704	648	602
2 1/2	4,860	3,340	2,680	2,290	2,030	1,840	1,690	1,580	1,480	1,400	1,240	1,120	1,030	960
3	8,580	5,900	4,740	4,050	3,590	3,260	3,000	2,790	2,610	2,470	2,190	1,980	1,820	1,700
4	17,500	12,000	9,660	8,270	7,330	6,640	6,110	5,680	5,330	5,040	4,460	4,050	3,720	3,460

Check inlet gas supply

WARNING DO NOT adjust or attempt to measure gas valve outlet pressure. Attempting to alter or measure the gas valve outlet pressure could result in damage to the valve, causing potential severe personal injury, death, or substantial property damage.

The gas piping must be sized for the proper flow and length of pipe, to avoid excessive pressure drop. Both the gas meter and the gas regulator must be properly sized for the total gas load.

If gas pressure drops more than 1 inch w.c. (249 Pa) between maximum and minimum input rate, the meter, regulator, or gas line may be undersized or in need of service. Perform the steps below when checking inlet gas supply:

1. Turn the main power switch to the "OFF" position.
2. Shut off gas supply at the manual gas valve in the gas piping to the appliance.
3. **For Crest models 751-2001:** Remove the 1/8" pipe plug on the gas manifold before the gas valve, and install a suitable 1/8" fitting (field supplied) for the manometer tubing. Place the tubing of the manometer over the tap once the 1/8" fitting is installed as shown in FIG. 2-4.

For Crest models 2501-6001: Remove the 1/8" pipe plug on the large gas valve flange before the gas valve, and install a suitable 1/8" fitting (field supplied) for the manometer tubing. Place the tubing of the manometer over the tap once the 1/8" fitting is installed as shown in FIG. 2-4.
4. Slowly turn on the gas supply at the factory installed manual gas valve.
5. Turn the power switch to the "ON" position.
6. Adjust the temperature set point on the control panel of the SMART TOUCH control module to call for heat or utilize Service Mode.
7. Observe the gas pressure with the burner operating at 100% of rated input. Without turning off the boiler, reduce the burner to the minimum input rate and observe the gas pressure with the burner at the minimum input rate. Percent of burner input will be displayed on the Modulation Screen.
8. Ensure inlet pressure is within specified range. Minimum and maximum gas supply pressures are specified in this section of the manual.
9. If gas supply pressure is within normal range and no adjustments are needed, proceed on to Step 11.
10. If the gas pressure is out of range, contact the gas utility, gas supplier, qualified installer or service agency to determine the necessary steps to provide proper gas pressure to the control.
11. Turn the power switch to the "OFF" position.
12. Shut off the gas supply at the manual gas valve in the gas piping to the appliance.
13. Remove the manometer from the pressure tap on the gas manifold or gas valve flange, depending on the model size. Remove the 1/8" (3mm) field supplied fitting and reinstall the pipe plug removed Step 3.

2 Gas connections

⚠ WARNING

Do not check for gas leaks with an open flame -- use the bubble test. Failure to use the bubble test or check for gas leaks can cause severe personal injury, death, or substantial property damage.

14. Turn on the gas supply at the manual gas valve.
15. Turn the power switch to the "ON" position.
16. Adjust the temperature set point on the control panel of the SMART TOUCH control module to the desired water temperature so the appliance will call for heat.
17. Check burner performance by cycling the system while you observe burner response. The burner should ignite promptly. Flame pattern should be stable. Turn system off and allow burner to cool, then cycle burner again to ensure proper ignition and flame characteristics.

Figure 2-4A Inlet Gas Supply Check - model 751-2001

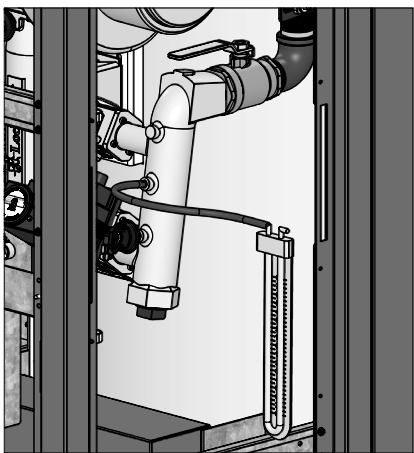

2000611010 00

Figure 2-4B Inlet Gas Supply Check - model 2501-6001

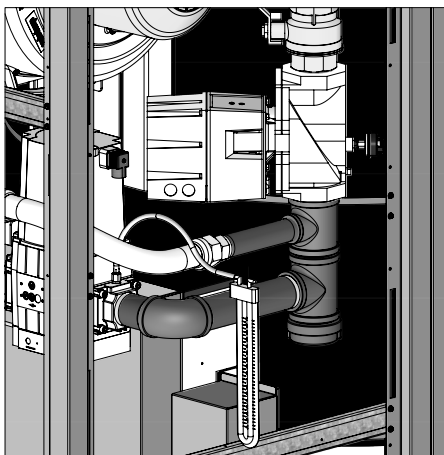

2000611008 00

Gas valve replacement

The gas valve MUST NOT be replaced with a conventional gas valve under any circumstances. As an additional safety feature, the gas valves have flanged connections to the venturi and the blower.

⚠ WARNING

Failure to follow all precautions could result in fire, explosion, or death!

⚠ WARNING

DO NOT adjust or attempt to measure gas valve outlet pressure. Attempting to alter or measure the gas valve outlet pressure could result in damage to the valve, causing potential severe personal injury, death, or substantial property damage.

3 Start-up

Pre-Commissioning Cleaning

1. Prior to fill and start-up, flush the entire heating system.
2. Clean the entire heating system with an approved pre-commissioning cleaner (comparable to Sentinel X300 or X400 and Fernox F3 or DS40) in accordance with the manufacturer’s recommendation to remove debris and prolong the life of the heat exchanger.
3. Clean all water filtering devices in the system.
4. Flush the cleaning solution out of the entire system and refill.

Fill water

Check/control fill water chemistry

IMPORTANT Conduct water quality testing prior to installing the appliance. Various solutions are available to adjust water quality.

The manufacturer recommends the following for properly filling your boiler with the appropriate water chemistry for closed loop boilers. Good fill water quality will help extend the life of the appliance by reducing the effects of lime scale buildup and corrosion in closed loop systems.

Hardness between 5 and 12 grains per gallon

1. Consult local water treatment companies for hard water areas (above 12 grains per gallon hardness).
2. Hardness levels that are above 12 grains/gallon can lead to lime scale buildup throughout the boiler system. If the fill water is below 5 grains/gallons, usually due to use of a water softener, it is recommended to mix in some potable water at the inlet to increase the hardness of the water to above 5 grains/gallons.

pH between 6.5 and 8.5

1. pH levels below 6.5 can cause an increase in the rate of corrosion. pH of 8.5 or higher can potentially cause lime scale buildup.

Total Dissolved Solids (TDS) less than 350 ppm

1. Total dissolved solids are all minerals, salts, metals, and charged particles that are dissolved in water.
2. The greater the amounts of TDS present, the higher the corrosion potential due to increased conductivity in the water.

Chloride concentration less than 150 ppm

1. Do not fill boiler or operate with water containing chlorine in excess of 150 ppm.
2. Filling with fresh drinking water should be acceptable.
3. Do not use the boiler to directly heat swimming pool or spa water.

Boiler water

Do not use petroleum based cleaning or sealing compounds in the boiler system. Gaskets and seals in the system may be damaged. This can result in substantial property damage.

DO NOT use "homemade cures" or "boiler patent medicines". Serious damage to boiler, personnel, and/or property may result.

Table 3A Boiler Water Chemistry

BOILER WATER CHEMISTRY	
Specification	Range
Dissolved Solids	< 2000 ppm
pH Level	6.5 to 9.5
Chloride	< 150 ppm

- Monitoring pH, chlorides, TDS, and hardness levels can prolong the life of the appliance by reducing lime scale buildup, corrosion, and erosion. Check for leaks to ensure that fresh water is not entering the system.
- Continual fresh makeup water will reduce boiler life.
- Mineral buildup in the heat exchanger reduces heat transfer, overheats the stainless steel heat exchanger, and causes failure.
- The addition of oxygen carried in by makeup water can cause internal corrosion in system components.
- Leaks in the boiler or piping must be repaired at once to prevent excessive makeup water. For this purpose, it is recommended to install a water meter to easily check the amount of makeup water entering the system. Makeup water volume should not exceed 5% of the total system volume per year. Note: When makeup water is added, make sure the chemical additives are added to maintain the correct level.
- An approved multi-metal corrosion inhibitor (comparable to Sentinel X100 or Fernox F1) is recommended at the correct concentration and in the manner recommended by the manufacturer.

3 Start-up

Oxygen prevention

CAUTION Eliminate all system leaks. Continual fresh makeup water will reduce boiler life. Minerals can build up in the heat exchanger, reducing heat transfer, overheating the heat exchanger, and causing heat exchanger failure.

Dissolved oxygen can have a negative effect on the boiler system. Oxygen can cause iron oxide to generate iron deposits. Oxygen may also increase the rate of corrosion on non-stainless steel parts of the system. A low pH level combined with oxygen further enhances its corrosive effects. After boiler installation, check for air leaks in the following areas:

- Suction gasket
- Pump
- Air valve
- O-ring gaskets

Precautions include installing a water meter to evaluate the fresh water volume entering the system (should be no more than 5% system volume). Additional volumes of fresh water could indicate that a leak is present.

Fill and test water system

1. Fill system only after ensuring the water meets the requirements of this manual.
2. Close automatic and manual air vents and boiler drain valve.
3. Fill to correct system pressure. Correct pressure will vary with each application.
 - a. The minimum cold water fill pressure for a system is 12 psi.
 - b. Pressure will rise when the boiler is turned ON and system water temperature increases.
4. At initial fill and during boiler startup and testing, check the system thoroughly for any leaks. Repair all leaks before proceeding further.

Purge air from water system

1. Purge air from system:
 - a. Connect a hose to the purge valve. Route the hose to an area where water can drain and be seen.
 - b. Close the boiler or system isolation valve between the purge valve and fill connection to the system.
 - c. Close zone isolation valves.
 - d. Open the quick-fill valve on the cold water makeup line.
 - e. Open purge valve.

- f. Open the isolation valves one zone at a time. Allow water to run through the zone, pushing out the air. Run until no noticeable air flow is present. Close the zone isolation valves and proceed with the next zone. Follow this procedure until all zones are purged.
 - g. Close the quick-fill water valve and purge valve and remove the hose. Open all isolation valves. Watch that system pressure rises to correct cold-fill pressure.
 - h. After the system has operated for a while, eliminate any residual air by using the manual air vents located throughout the system.
 - i. If purge valves are not installed in the system, open the manual air vents in the system one at a time, beginning with the lowest floor. Close the vent when water squirts out. Repeat with remaining vents.
2. Open the automatic air vent (diaphragm-type or bladder type expansion tank systems only) one turn.
 3. Open other vents:
 - a. Starting on the lowest floor, open air vents one at a time until water squirts out.
 - b. Repeat with remaining vents.
 4. Refill to correct pressure.

Check for gas leaks

WARNING Before starting the boiler, and during initial operation, smell near the floor and around the boiler for gas odorant or any unusual odor. Remove the top access panel and smell the interior of the boiler enclosure. Do not proceed with startup if there is any indication of a gas leak. Use an approved leak detection solution. Repair any leaks at once.

WARNING DO NOT adjust or attempt to measure gas valve outlet pressure. The gas valve is factory set for the correct outlet pressure. This setting is suitable for natural gas and propane, requiring no field adjustment. Attempting to alter or measure the gas valve outlet pressure could result in damage to the valve, causing potential severe personal injury, death, or substantial property damage.

3 Start-up *(continued)*

WARNING Propane boilers only – Your propane supplier mixes an odorant with the propane to make its presence detectable. In some instances, the odorant can fade, and the gas may no longer have an odor. Before startup (and periodically thereafter), have the propane supplier verify the correct odorant level in the gas.

Check thermostat circuit(s)

1. Disconnect the two external wires connected to the enable terminals on the connection board.
2. Connect a voltmeter across these two incoming wires. Close each thermostat, zone valve, and relay in the external circuit one at a time and check the voltmeter reading across the incoming wires.
3. There should NEVER be a voltage reading.
4. If a voltage does occur under any condition, check and correct the external wiring. (This is a common problem when using 3-wire zone valves.)
5. Once the external boiler enable wiring is checked and corrected if necessary, reconnect the external thermostat circuit wires to the connection board. Allow the boiler to cycle.

Inspect condensate system

Inspect/check condensate lines and fittings

1. Inspect the condensate drain line, condensate PVC fittings and condensate trap.

Figure 3-1 Condensate Trap

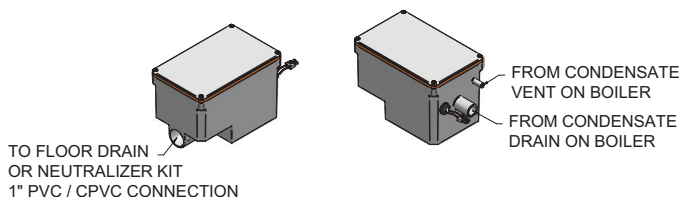

Final checks before starting the boiler

- Read the Crest Service Manual to familiarize yourself with SMART TOUCH control module operation. Read this manual, page 19 for proper steps to start boiler.
- Verify the boiler and system are full of water and all system components are correctly set for operation.
- Verify the preparation procedures of Section 3 pages 15 - 18 have been completed.
- Verify electrical connections are correct and securely attached.
- Inspect vent piping and air piping for signs of deterioration from corrosion, physical damage or sagging. Verify air piping and vent piping are intact and correctly installed per this manual.

Start the boiler

1. Read and follow the Operating instructions in FIG. 3-3, page 19.

If boiler does not start correctly

1. Check for loose connections, blown fuse or service switch off?
2. Is external limit control (if used) open? Is boiler water temperature above 200°F (93°C)?
3. Is the boiler receiving a call for heat?
4. Is gas turned on at meter and boiler?
5. Is incoming gas pressure less than 4 inches w.c. (.99 kPa)?
6. Ignition problems are especially noticeable in new LP installations and also in empty tank situations. This can also occur when a utility company shuts off service to an area to provide maintenance to their lines.

If none of the above corrects the problem, refer to the Troubleshooting Section of the Crest Service Manual.

Check system and boiler

- Check water piping**
 1. Check system piping for leaks. If found, shut down the boiler and repair immediately. (See WARNINGS on pages 15 - 18 (startup) regarding failure to repair leaks.)
 2. Vent any remaining air from the system using manual vents. Air in the system will interfere with circulation and cause heat distribution problems and noise.

3 Start-up

Check vent piping and air piping

1. Check for gastight seal at every connection, seam, and vent piping.

WARNING Venting system must be sealed gastight to prevent flue gas spillage and carbon monoxide emissions, which will result in severe personal injury or death.

Check gas piping

1. Check around the boiler for gas odor following the procedure on page 11 of this manual (connecting gas supply piping).

WARNING If you discover evidence of any gas leak, shut down the boiler at once. Find the leak source with a bubble test and repair immediately. Do not start the boiler again until corrected. Failure to comply could result in severe personal injury, death, or substantial property damage.

Check flame and combustion

1. Turn the main power off to the boiler by placing the “On/Off” switch in the OFF position.
2. Remove the fitting from the flue collector. **Note:** Combustion measurements will be made at this point.
3. Insert the probe from a combustion analyzer into the hole left by the removal of the fitting.
4. Turn the main power on to the boiler by placing the “On/Off” switch in the ON position.
5. Navigate to the Setup Screen from the Home Screen by pressing the SETUP button along the left side of the screen. Enter the installer password.
6. Select the Service Maintenance Screen. The tabs will scroll (up and down) to reveal more options.

On the Service Maintenance Screen place heater into Service Mode by selecting the START button, then selecting **Set Gas Valve 1 - High** (FIG. 3-2).

7. Once the boiler has modulated up to rate, measure the combustion. The values should be in the range listed in Table 3B (this page). CO levels should be less than 200 ppm for a properly installed unit. If the combustion is not within range reference the *Troubleshooting* Section in the Outdoor Crest Service Manual for possible causes and corrective actions.

Table 3B Flue Products Chart **ADD O2 SENSOR?**

Flue Products				
Units	Natural Gas			
	751-2001		2501-6001	
Gas Valve	CO ₂ (%)	O ₂ (%)	CO ₂ (%)	O ₂ (%)
Valve 1 High	9.2	4.6	9.2	4.6
Valve 1 Low	9.0	4.9	8.5	5.7
Valve 2 High	9.3	4.4	9.5	4.2
Valve 2 Low	8.7	5.5	8.8	5.4
Propane				
Units	751-2001		2501-6001	
Gas Valve	CO ₂ (%)	O ₂ (%)	CO ₂ (%)	O ₂ (%)
Valve 1 High	11.0	4.1	11	4.1
Valve 1 Low	10.0	5.6	9.9	5.7
Valve 2 High	11.1	4.0	11.1	4
Valve 2 Low	10.7	4.6	10.1	5.5

All set points should be within +/- 0.2%

8. Once the heater analysis is complete, test the safety shutoff device by turning the manual shutoff valve to the OFF position and ensuring the heater shuts down and registers an alarm. Open the manual shutoff valve and reset the control.
9. Turn the main power off to the boiler and replace the fitting into the flue pipe connection.
10. Ensure the boiler is placed back into normal operation.

WARNING You must replace the fitting to prevent flue gas spillage into the room. Failure to comply could result in severe personal injury, death, or substantial property damage.

Figure 3-2 Service Maintenance Screen



3 Start-up *(continued)*

Figure 3-3 Operating Instructions

FOR YOUR SAFETY READ BEFORE OPERATING

WARNING: If you do not follow these instructions exactly, a fire or explosion may result causing property damage, personal injury, or loss of life.

- A. This appliance does not have a pilot. It is equipped with an ignition device which automatically lights the burner. Do not try to light the burner by hand.
 - B. BEFORE OPERATING smell all around the appliance area for gas. Be sure to smell next to the floor because some gas is heavier than air and will settle on the floor.
- WHAT TO DO IF YOU SMELL GAS**
- Do not try to light any appliance.
 - Do not touch any electric switch; do not use any phone in your building.
 - Immediately call your gas supplier from a neighbor's phone. Follow the gas supplier's instructions.
 - If you cannot reach your gas supplier, call the fire department.
- C. Use only your hand to turn the gas control knob. Never use tools. If the handle will not turn by hand, don't try to repair it, call a qualified service technician. Force or attempted repair may result in a fire or explosion.
 - D. Do not use this appliance if any part has been under water. Immediately call a qualified service technician to inspect the appliance and to replace any part of the control system and any gas control which has been under water.

OPERATING INSTRUCTIONS

1. **STOP!** Read the safety information above on this label.
2. Set the thermostat to lowest setting.
3. Turn off all electric power to the appliance.
4. This appliance is equipped with an ignition device which automatically lights the burner. Do not try to light the burner by hand.
5. Remove front door.
6. Turn gas shutoff valve counterclockwise to "OFF". Handle will be perpendicular to pipe. Do not force.
7. Wait five (5) minutes to clear out any gas. If you then smell gas, **STOP!** Follow "B" in the safety information above this label. If you don't smell gas, go to next step.
8. Turn gas shutoff valve clockwise to "ON". Handle will be parallel to pipe.
9. Install front door.
10. Turn on all electric power to appliance.
11. Set thermostat to desired setting.
12. If the appliance will not operate, follow the instructions "To Turn Off Gas To Appliance" and call your service technician or gas supplier.

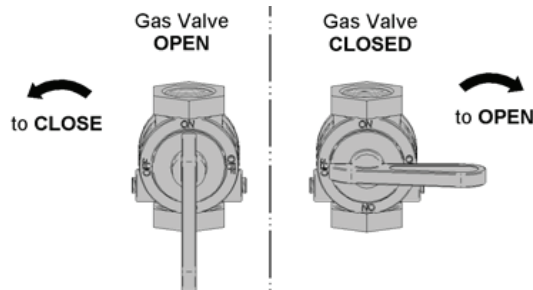

TO TURN OFF GAS TO APPLIANCE

1. Set the thermostat to lowest setting.
2. Turn off all electric power to the appliance if service is to be performed.
3. Remove front door.
4. Turn gas shut off valve counterclockwise to "OFF". Handle will be perpendicular to pipe. Do not force.
5. Install front door.

LBL2005 3 REV B

4 Diagrams

Figure 4-1 Ladder Diagram_751 - 2001 Models

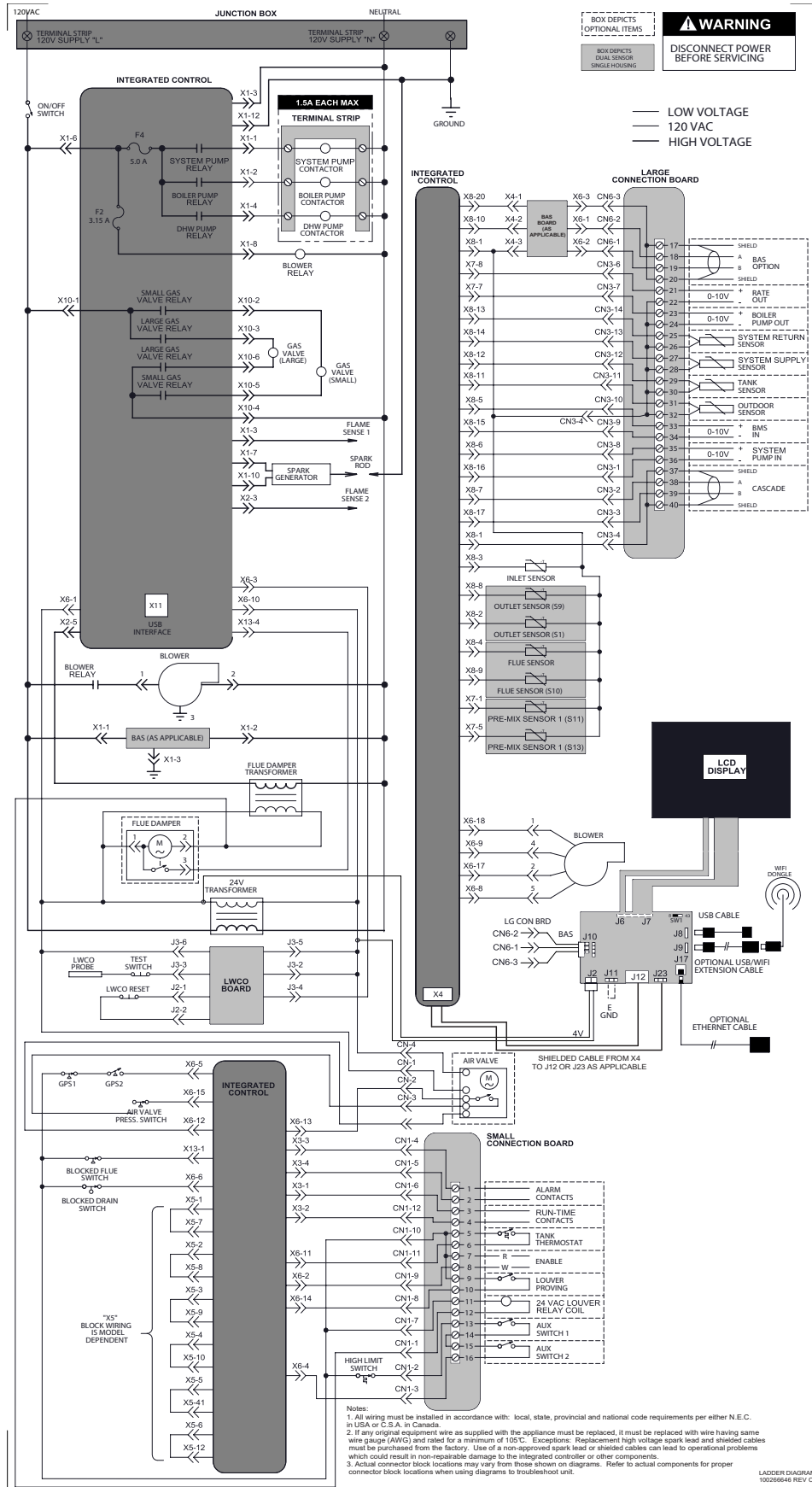

4 Diagrams (continued)

Figure 4-2 Wiring Diagram_751 - 2001 Models

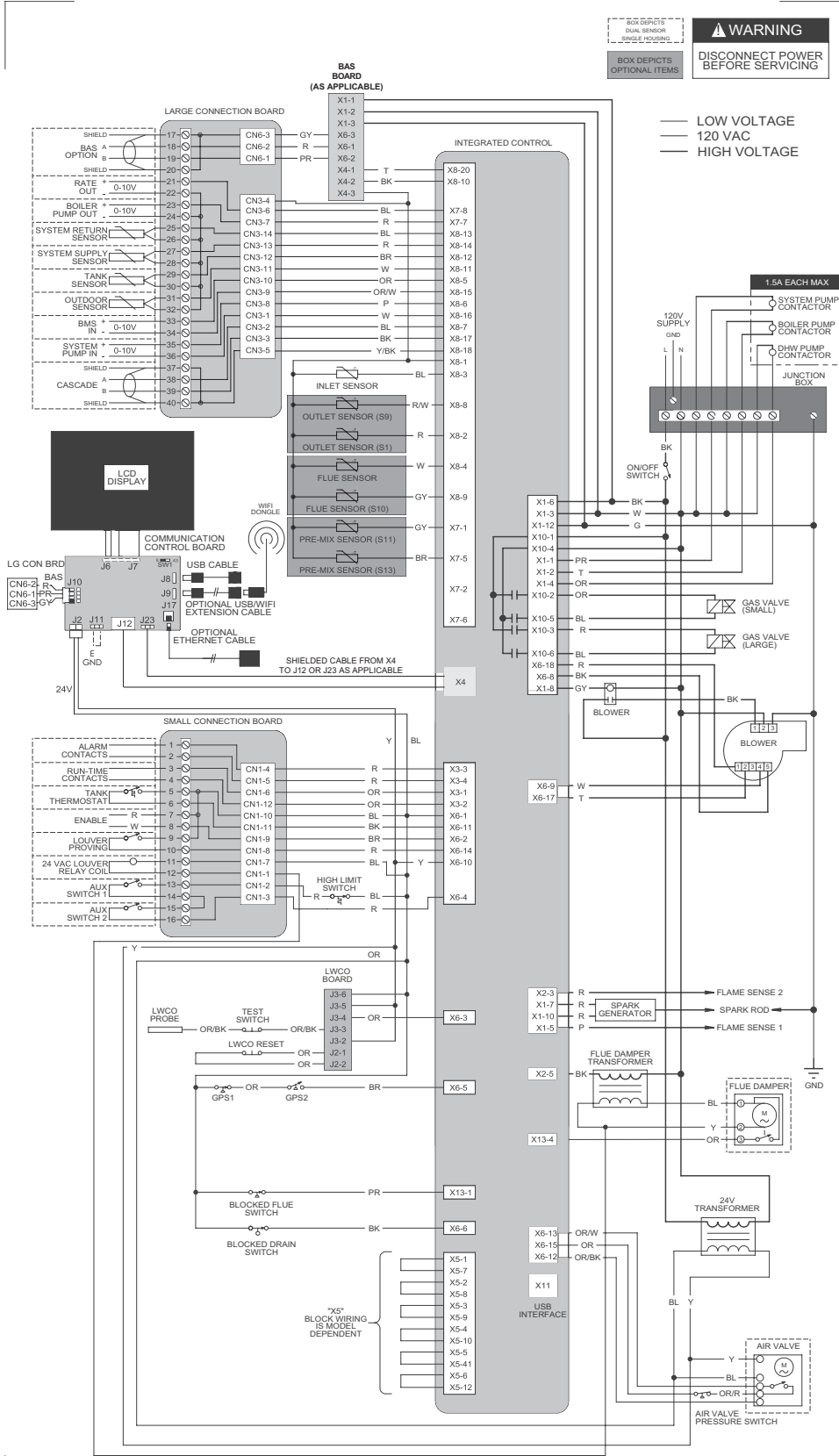

Notes:
 1. All wiring must be installed in accordance with local, state, provincial and national code requirements per either N.E.C. in USA or C.S.A. in Canada.
 2. If any original equipment wire as supplied with the appliance must be replaced, it must be replaced with wire having same wire gauge (AWG) and rated for a minimum of 105°C. Exceptions: Replacement high voltage spark lead and shielded cables must be purchased from the factory. Use of a non-approved spark lead or shielded cables can lead to operational problems which could result in non-repairable damage to the integrated controller or other components.
 3. Actual connector block locations may vary from those shown on diagrams. Refer to actual components for proper connector block locations when using diagrams to troubleshoot unit.

WIRING DIAGRAM
 10026647 REV.C

4 Diagrams

Figure 4-3 Ladder Diagram_2501 - 3501 Models

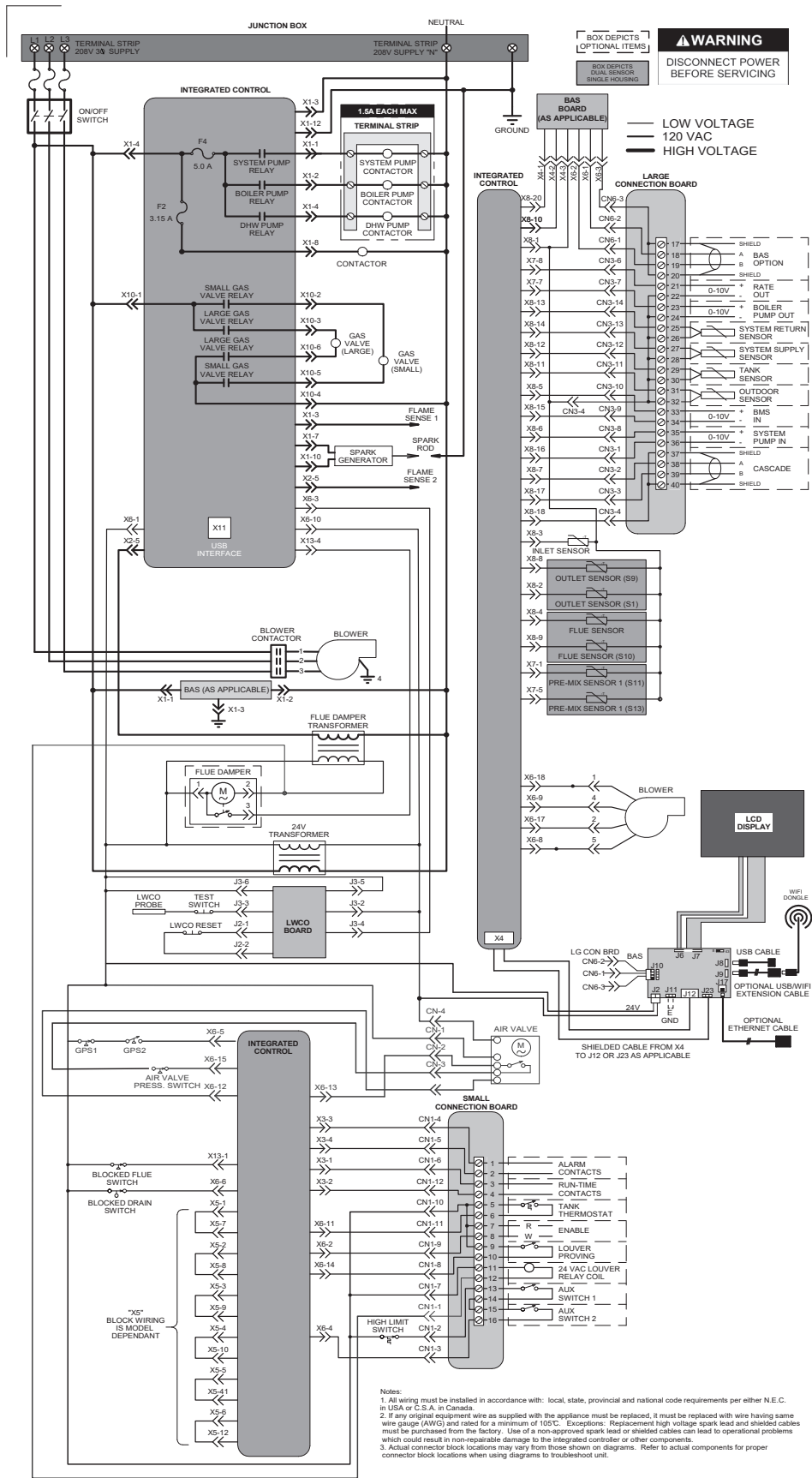

4 Diagrams (continued)

Figure 4-4 Wiring Diagram_2501 - 3501 Models

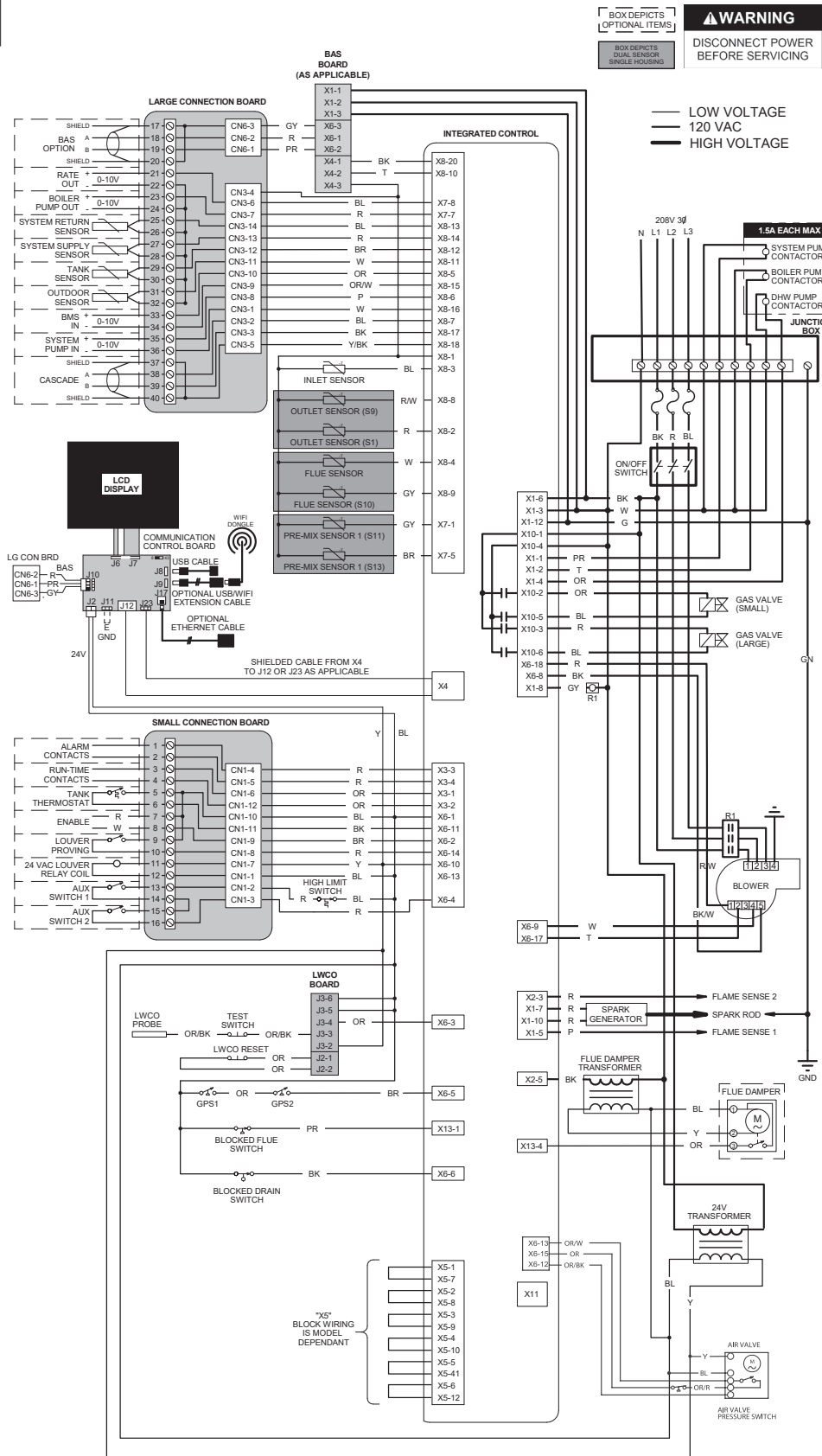

WIRING DIAGRAM
1001234 REV A

4 Diagrams

Figure 4-5 Ladder Diagram_4001 - 5001 Models

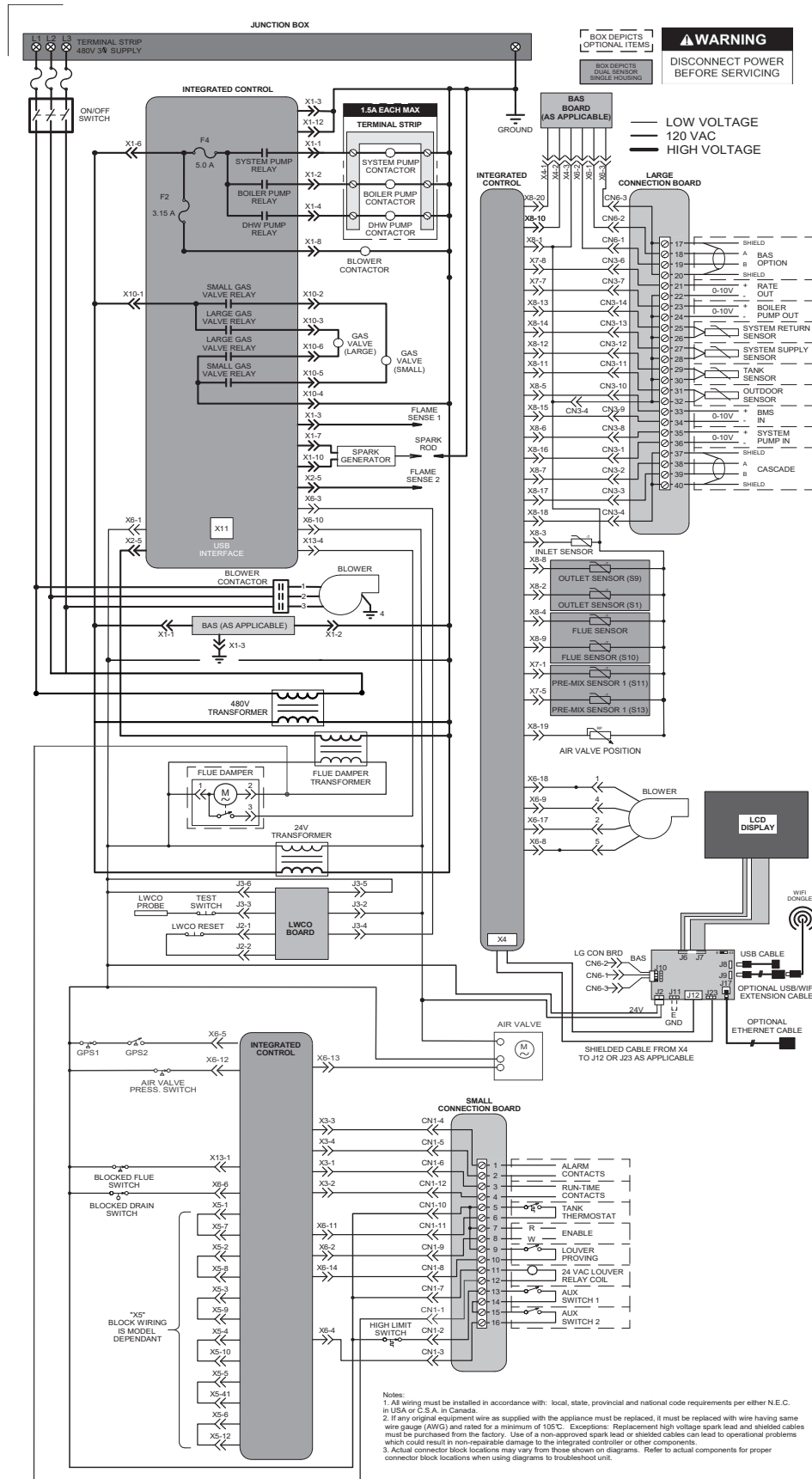

4 Diagrams (continued)

Figure 4-8 Wiring Diagram_6001 Model

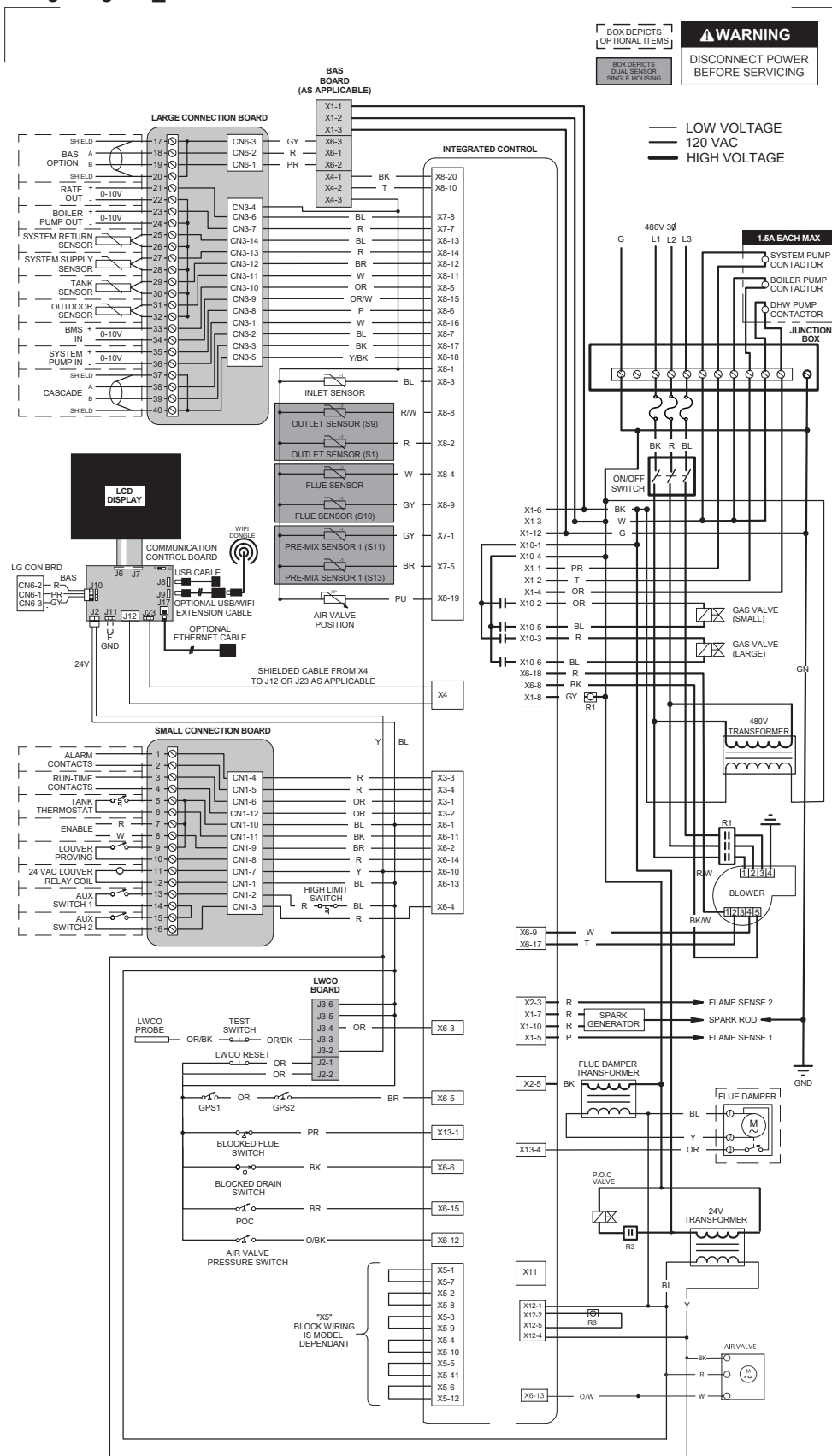

Notes:
 1. All wiring must be installed in accordance with local, state, provincial and national code requirements per either N.E.C. in USA or C.S.A. in Canada.
 2. If any original equipment wire as supplied with the appliance must be replaced, it must be replaced with wire having same wire gauge (AWG) and rated for a minimum of 105°C. Exceptions: Replacement high voltage spark lead and shielded cables must be purchased from the factory. Use of a non-approved spark lead or shielded cables can lead to operational problems which could result in non-repairable damage to the integrated controller or other components.
 3. Actual connector block locations may vary from those shown on diagrams. Refer to actual components for proper connector block locations when using diagrams to troubleshoot unit.

WIRING DIAGRAM 1000X13 REV A

Revision Notes: *Revision A (PCP# 3000023718 / CN# 500013605) initial release.*

Revision B (PCP #3000027910 / CN #500017507) reflects the addition of the 3501 model, updates made to the Check Flame and Combustion Section on page 18, and the wiring and ladder diagrams.

Revision C (PCP #3000029182 / CN #500018624) reflects the addition of the 2501 - 3001 and 4001 - 6001 models.

Revision D (PCP #3000033824 / CN #500022616) reflects the addition of the silicone sealant note and edits made to the install outdoor kit on page 9 as well as an update to the ratings table.

Revision E (PCP #3000035711 / CN #500024133) reflects an update to the Ratings Table and Table 2A.

Revision F (PCP #3000042364 / CN #500030203) reflects updates to the wiring and ladder diagrams.

Revision G (PCP #3000049605 / CN #500036675) Remove Series numbers

Revision H (PCP #3000049089 / CN #500036206) reflects updates to the gas connection instructions on page 13 and the image for FIG. 2-4 on page 14.

Revision J (PCP #3000053380 / CN #500039995) reflects updates to the wiring and ladder diagrams on pages 22 through 27.

Revision K (PCP #3000057732 / CN #500043895) reflects the addition of a carbon monoxide warning on page 3.

Revision L (PCP #3000062176 / CN #500048407) reflects updated ladder diagrams.