



Lochinvar[®]

HIGH EFFICIENCY BOILERS & WATER HEATERS

KNIGHT XL COMMERCIAL BOILER

Submittal Sheet

KBX-Sub-08

KNIGHT XL COMMERCIAL CONDENSING HEATING BOILERS

Job Name: _____ Model No. _____
 Location: _____ Type Gas: _____
 Engineer: _____ Equipment Tag(s): _____
 Agent/Wholesaler: _____
 Contractor: _____

NOTES:

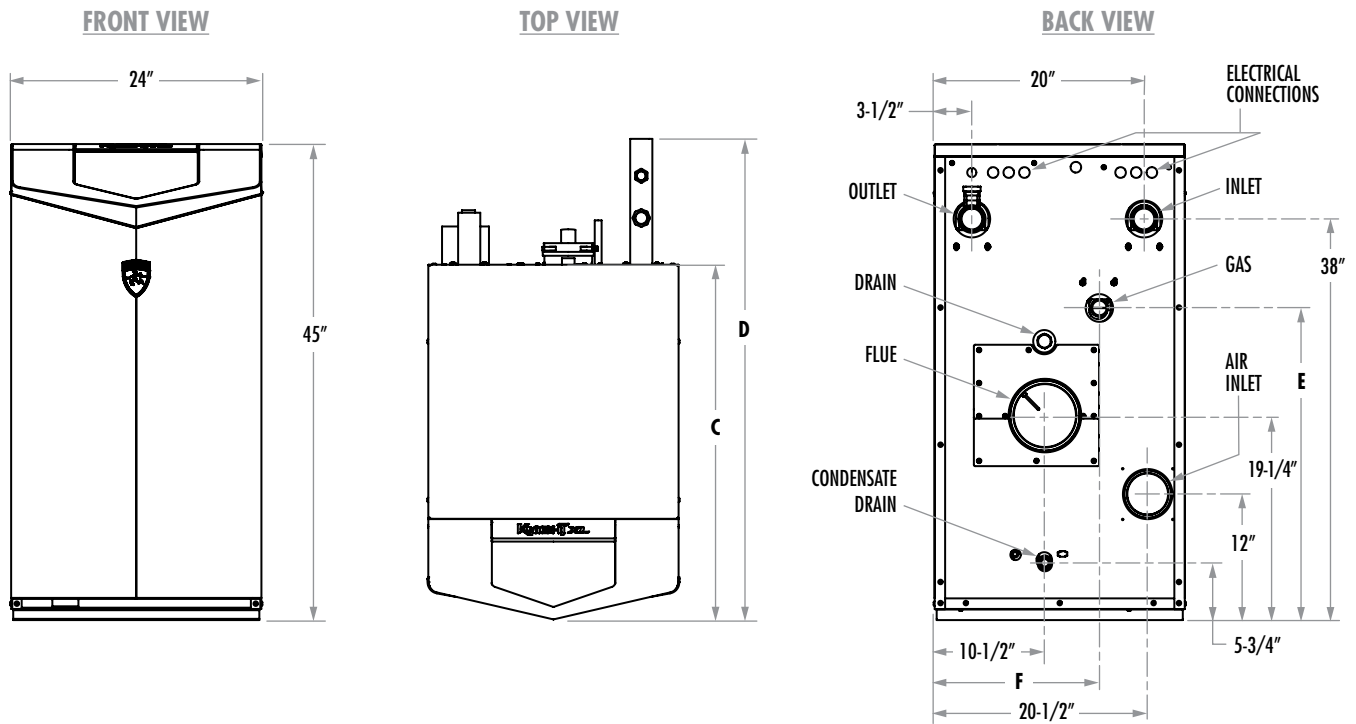

Dimensions & Specifications

Model Number	Input MBH		Thermal Efficiency	Gross Output MBH	Net AHRI Rating MBH	C	D	E	F	Gas Conn.	Water Conn.	Air Inlet	Vent Size	Ship. Weight (lbs.)
	Max Btu/Hr	Min Btu/Hr												
KBX0400N	399,000	39,900	97%	387	337	33-1/2"	42-1/2"	29-3/4"	20-1/4"	1"	2"	4"	4"	365
KBX0500N	500,000	50,000	97%	485	422	33-1/2"	42-1/2"	29-3/4"	20-1/4"	1"	2"	4"	4"	377
KBX0650N	650,000	65,000	97%	631	549	42-1/2"	53"	30-1/2"	15-1/4"	1-1/4"	2"	4"	6"	456
KBX0800N	800,000	80,000	97%	776	675	42-1/2"	53"	30-1/2"	15-1/4"	1-1/4"	2"	4"	6"	484
KBX1000N	999,000	99,900	97%	969	843	50"	62"	30-1/2"	15-3/4"	1-1/4"	2-1/2"	6"	6"	567

Notes:

- Indoor installation only. All information subject to change. Change "N" to "L" for LP gas models.
- The Net AHRI Water Ratings shown are based on a piping and pickup allowance of 1.15.
- Lochinvar should be consulted before selecting a boiler for installations having unusual piping and pickup requirements, such as intermittent system operation, extensive piping systems, etc.
- The ratings have been determined under the provisions governing forced draft burners.



Standard Features

- › **97% Thermal Efficiency**
- › **Modulating Burner with 10:1 Turndown**
 - Direct Spark Ignition
 - Low NOx Operation
 - Sealed Combustion
 - Low Gas Pressure Operation
- › **Stainless Steel Water Tube Heat Exchanger**
 - ASME-Certified, “H” Stamped
 - 160 psi Working Pressure
 - 50 psi Relief Valve
 - Combustion Analyzer Test Port
 - Fully Welded Design
- › **Smart System Control**
- › **Vertical and Horizontal Direct Vent**
 - Direct Vent up to 150 feet
 - PVC, CPVC, Polypropylene or AL29-4C
- › **Other Features**
 - On/Off Switch
 - Adjustable High Limit with Manual Reset
 - Automatic Reset High Limit
 - Flow Switch
 - Flue Temperature Sensor
 - Low Air Pressure Switch
 - Temperature and Pressure Gauge
 - Condensate Trap
 - 10-Year Limited Warranty (See Warranty)

Smart System Features

- › **CON-X-US Remote Connect**
- › **Smart Touch Touchscreen Operating Control**
- › **Full Color 7” Touchscreen LCD Display**
- › **Loch-N-Link® USB Thumb Drive Port for Easy Programming**
- › **Cascading Sequencer with Built-in Redundancy**
 - Selectable Cascade Type:*
 - Lead Lag or Efficiency Optimization
 - Multiple Size Boilers
 - Front-End Loading
- › **3 Reset Temperatures Inputs w/Independent Outdoor Reset Curves for Each**
 - Outdoor Sensor
- › **Four-Pump Control**
 - System Pump with Parameter for Continuous Operation
 - Boiler Pump with Variable-Speed Control
 - Domestic Hot Water Boiler Pump
 - Domestic Hot Water Recirculation Pump Control with Sensor
- › **Building Management System Integration**
 - 0-10 VDC Input to Control Modulation or Setpoint
 - 0-10 VDC Input from Variable-Speed System Pump
 - 0-10 VDC Modulation Rate Output Signal
 - 0-10 VDC Enable/Disable Signal
- › **Programmable System Efficiency Optimizers**
 - Space Heating Night Setback
 - DHW Night Setback
 - Anti-Cycling
 - Ramp Delay
 - Boost Time and Temperature
- › **High-Voltage Terminal Strip**
 - 120 VAC/60 Hertz/1 Phase
 - Pump Contacts for 3 Pumps
- › **Low-Voltage Terminal Strip**
 - Building Recirculation Pump Start/Stop
 - Proving Switch Contacts
 - Alarm Contacts
 - Runtime Contacts
 - 3 Space Heat Thermostat Contacts
 - Tank Thermostat Contacts
 - System Sensor Contacts
 - Tank Sensor Contacts
 - Cascade Contacts
 - 0-10 VDC BMS Contacts
 - 0-10 VDC Boiler Rate Output Contacts
 - 0-10 VDC Boiler Pump Speed Contacts
 - 0-10 VDC System Pump Speed Contacts
 - ModBus/BACnet Contacts
- › **Time Clock**
- › **Data Logging**
 - Ignition Attempts
 - Last 10 Lockouts
 - Space Heat Run Hours
 - Domestic Hot Water Run Hours
 - Custom Maintenance Reminder w/ Contact Info
 - Password Security
 - Customizable Freeze Protection Parameters

Optional Equipment

- Wireless Outdoor Temperature Sensor
- Multi-Temperature Loop Control
- Variable-Speed Boiler Circulator
- Constant-Speed Boiler Circulator
- ModBus Communication
- BMS Gateway to BACnet or LonWorks
- BACnet MSTP
- Alarm on Any Failure
- Condensate Neutralization Kit
- Concentric Vent Kit (KBX0400-KBX650)
- High and Low Gas Pressure Switches w/Manual Reset (KBX0500-KBX1000)

Firing Codes

- M9 Standard Construction
- M13 CSD1/FM/GE Gap (KBX0500-KBX1000)

Venting Options

- Direct Vent Vertical
- Direct Vent Horizontal
- Vertical Vent with Sidewall Air Intake
- Sidewall Vent with Rooftop Air Intake
- Vertical Vent with Optional Room Air
- Sidewall Vent with Optional Room Air



Lochinvar, LLC
 300 Maddox Simpson Parkway
 Lebanon, Tennessee 37090
 P: 615.889.8900 / F: 615.547.1000
 Lochinvar.com

