



REMOTE CONNECT  
INSTALLATION & OPERATION  
INSTRUCTIONS

**Models: FTXL and Knight**



**⚠ WARNING**

This manual must only be used by a qualified heating installer / service technician. Read all instructions, including this manual, the Installation and Operation Manuals, and the Service Manuals, before installing. Perform steps in the order given. Failure to comply could result in severe personal injury, or substantial property damage.



**Save this manual for future reference.**

# Contents

1. INTRODUCTION .....	2	4. PERMISSIONS.....	13-17
2. CON·X·US INSTALLATION		5. TROUBLESHOOTING.....	18
CON·X·US Board Layout .....	3	Revision Notes .....	Back Cover
List of Kit Components .....	3		
Gain Access to the Interior of the Unit .....	3		
Installation Procedure.....	4-6		
3. CON·X·US REGISTRATION			
Device Registration.....	7-12		
Site Manager .....	12		

## 1 Introduction

The information contained in this manual provides general guidelines for the implementation of the CON·X·US remote communication device with Lochinvar boilers.

Now from virtually anywhere you can:

- Monitor boiler plant operating conditions at unlimited locations
- Re-program SMART SYSTEM control parameters
- Setup custom text or e-mail alerts for contractor and building owners/managers

### CON·X·US board layout

**Figure 1-1**\_CON·X·US Board Components

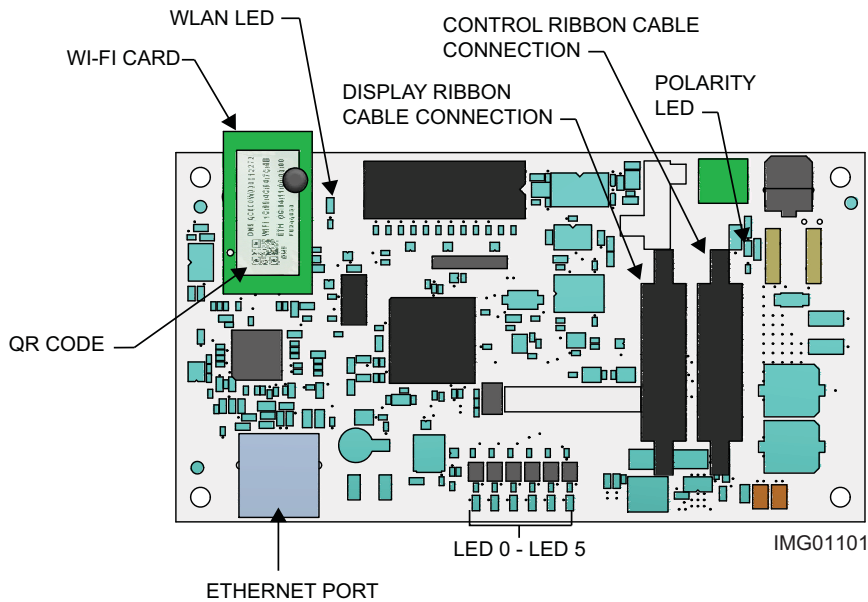

#### LED 0 - LED 5

LED	Description
LED 0	N/A
LED 1	Control to Display Communication Error
LED 2	CON·X·US Communication
LED 3	N/A
LED 4	Control to Display Communication
LED 5	Power Confirmation

## 2 CON·X·US Installation

Table 2A - List of kit components

Old Part #	New Part #	Description	FTXL	KB/ WH
			Qty	
BLT20133	100053762	SCREW, PHP, 6-32 X 1/4 STL	10	10
BLT2719	100134843	RIVET, NYLON PUSH	2	--
BLT2117	100134798	STAND-OFF, HEX 6-32 X 1/2 STL	4	4
MSC2430	100163015	BUSHING, SNAP 1-1/4"	2	--
CLP2013	100137491	CLIP, WIRE HARNESS, EXTRUDED	2	--
RLY20143	100094892	BOARD, CON·X·US	1	1
WRE20225	100189402	CABLE, RIBBON, 10 CIRCUIT X 74"	1	--
WRE20228	100190832	HARNESS, POWER, REMOTE, FTX	1	1
WRE20200	100172950	CABLE, RIBBON, 10 CIRCUIT X 14"	--	1

**⚠ WARNING**

Warning: **Electrical Shock Hazard** -- For your safety, turn OFF electrical power supply before making any electrical connections to avoid possible electric shock. Failure to do so can cause severe personal injury or death.

To gain access to the interior of the unit

1. Turn the main power OFF.
2. Turn the main manual gas shutoff to the appliance OFF.
3. Remove the front door panel (no tools required).

### Recommended tool(s)

- #2 Phillips Head Screwdriver
- 8 mm Wrench or 5/16" Wrench

Figure 2-1\_Gain Access to the Interior of the Unit

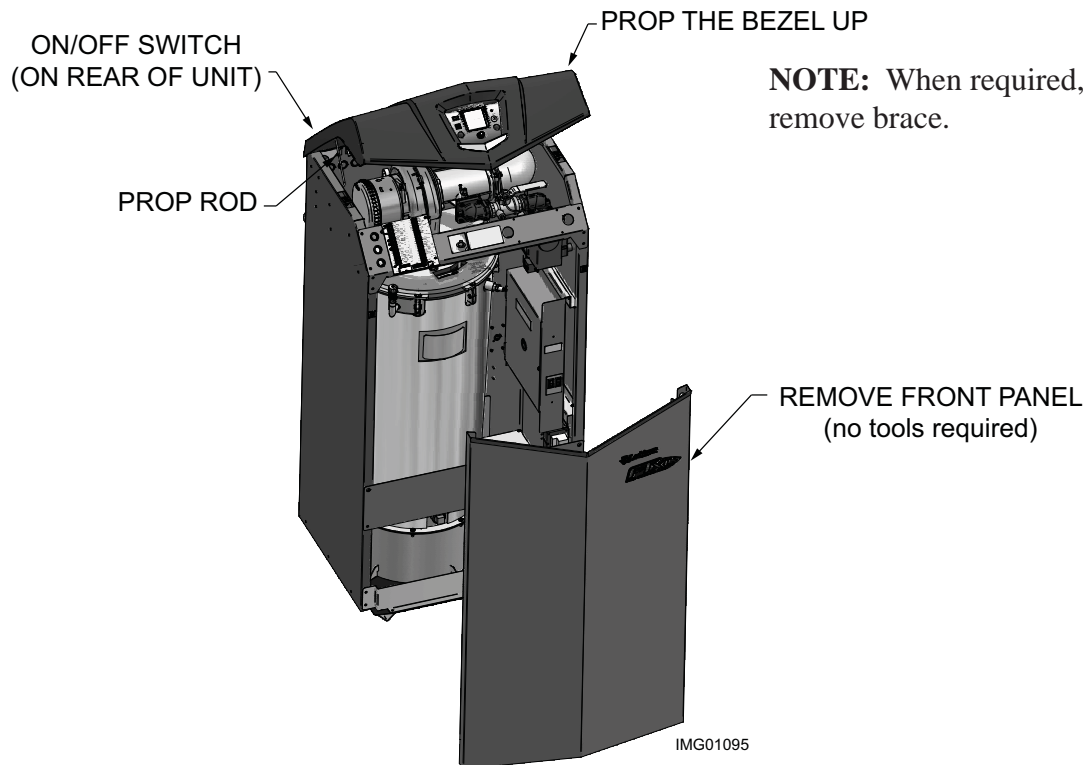

**NOTE:** When required, remove brace.

**NOTE:** FTXL shown for illustration purposes only.

# 2 CON·X·US Installation

## Installation procedure

1. Using four (4) BLT20133/100053762 screws, install the four (4) standoffs (BLT2117/100134798) into the four (4) small holes on the front right side of the unit (see FIG.'s 2-2A, 2-2B and 2-2C).
2. Using four (4) BLT20133/100053762 screws, install the CON·X·US board (RLY20143/100094892) onto the standoffs installed in Step 2.

Table 2B - List of bracket kits

Part #	Description
100265396	KIT,BRKT,BEZEL,CONXUS,KB
100265397	KIT,BRKT,BEZEL,CONXUS,WH

Figure 2-2A\_Install FTXL CON·X·US Board

**NOTE:** FTXL Models Only:

- a. Install two (2) push rivets (BLT2719/100134843) on the right side of the unit (reference Detail A). Once installed attach the harness clips (CLP2013/100137491) to the push rivets on the inside of the unit (Detail A), above the main control panel.
- b. Install two (2) bushings (MSC2430/100163015) into the left and right side of the CON·X·US board.

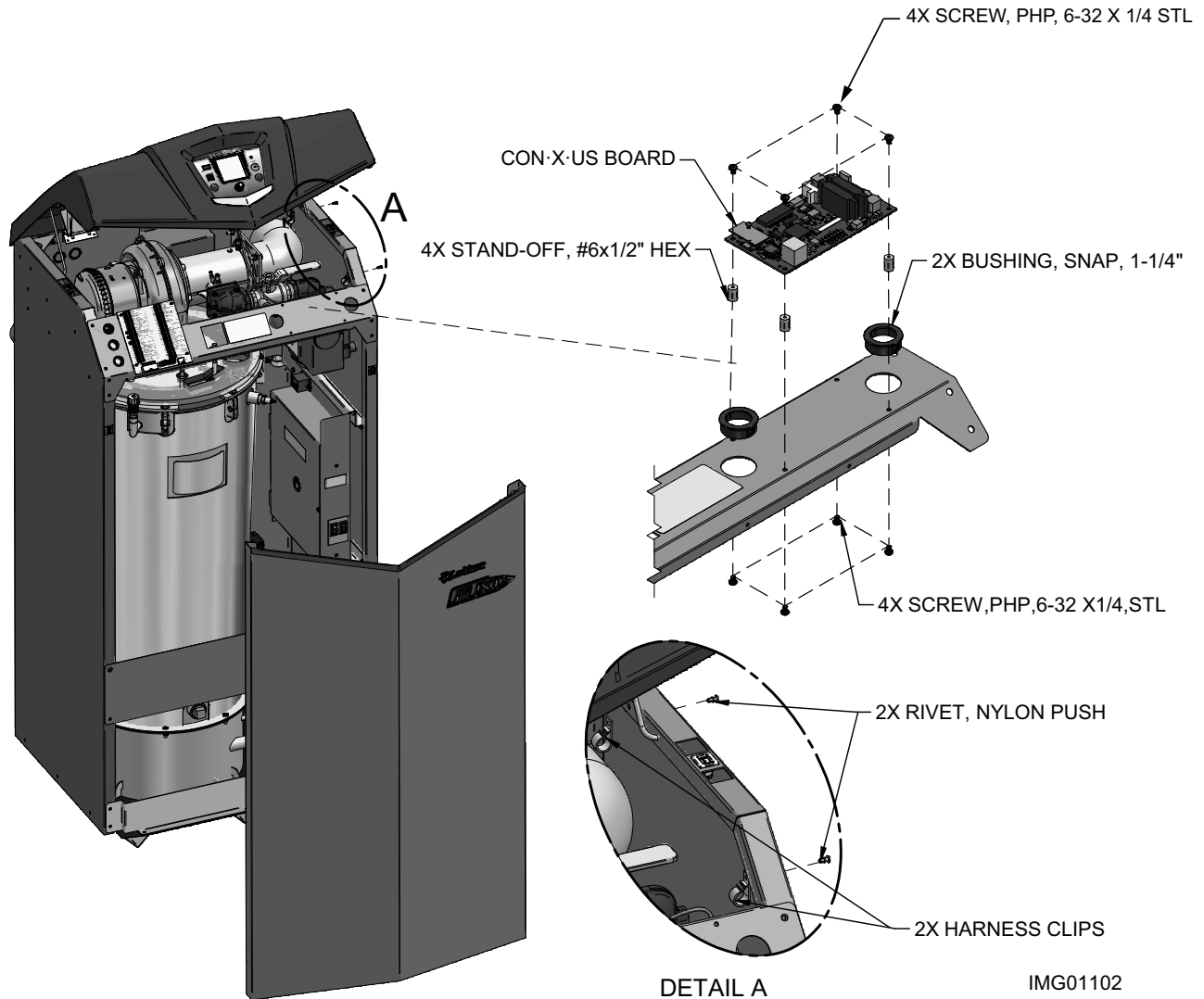

## 2 CON·X·US Installation *(continued)*

**Figure 2-2B**\_Install KB CON·X·US Board

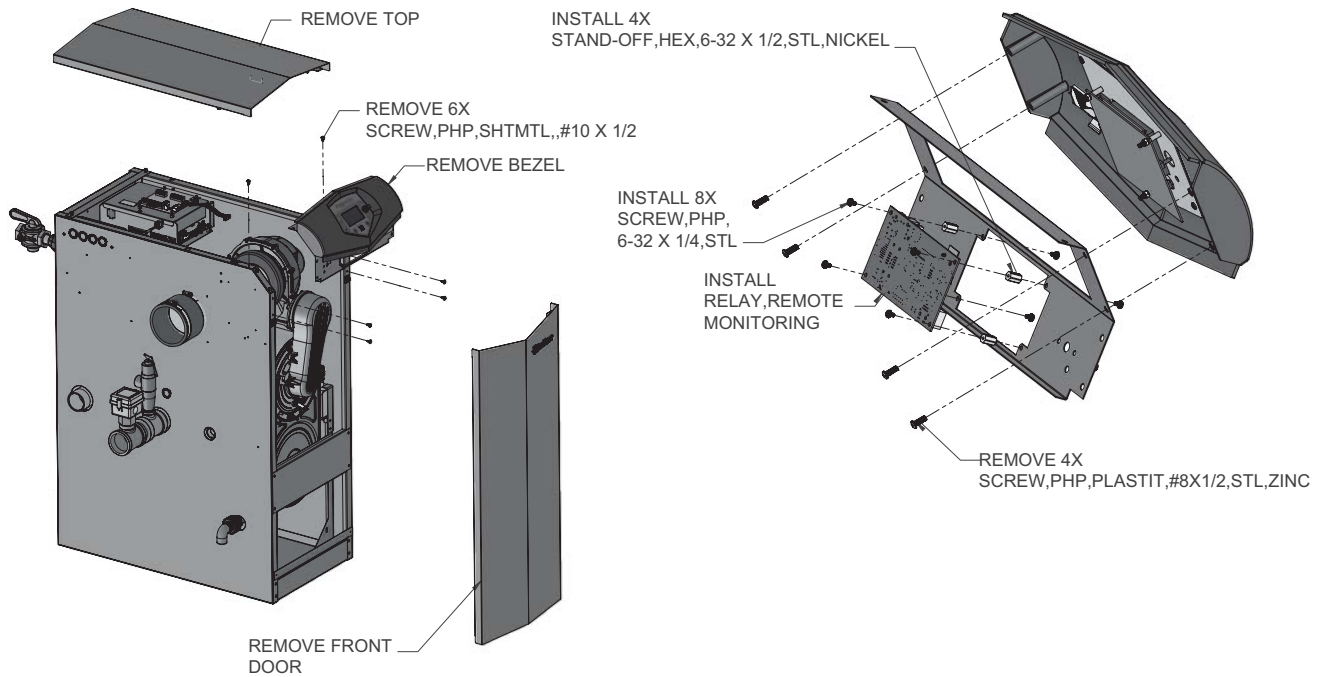

IMG01191

**NOTE:** On units purchased after Serial #1915 the bezel bracket will not be required. If purchased between Serial #H10 to D15 the bezel bracket (see Table 2B on page 4) is required. Units purchased prior to Serial #H10 are not compatible.

**Figure 2-2C**\_Install WH CON·X·US Board

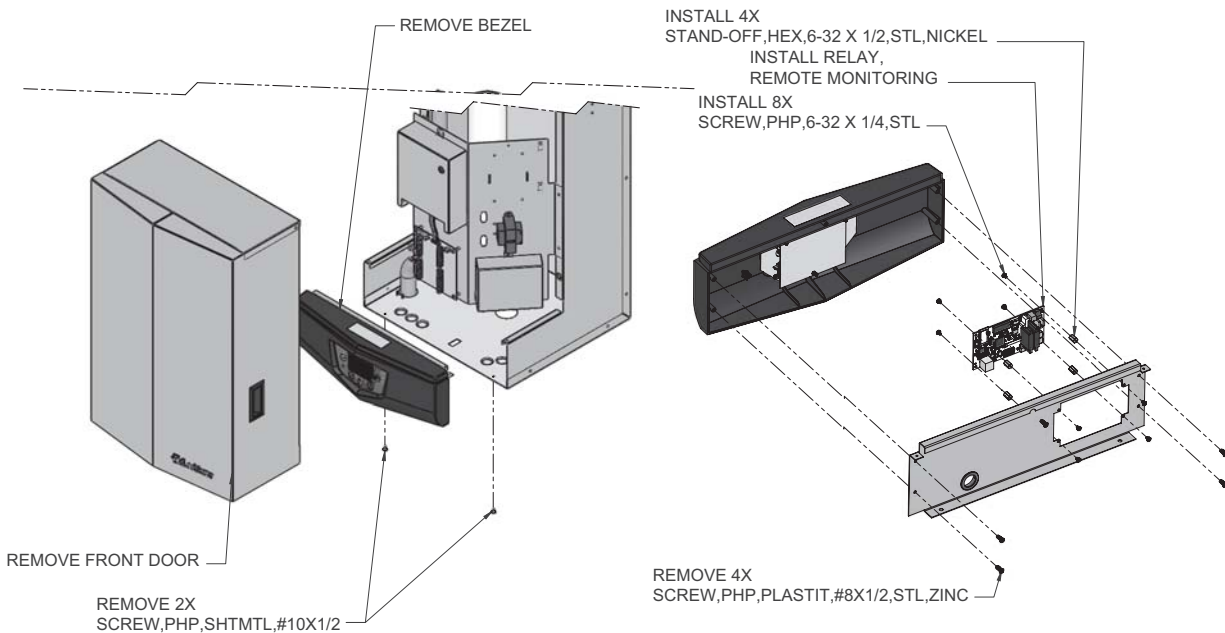

IMG01193

**NOTE:** On units purchased after Serial #1915 the bezel bracket will not be required. If purchased between Serial #H10 to D15 the bezel bracket (see Table 2B on page 4) is required. Be certain to record the CON·X·US board QR code (see FIG. 3-9 on page 11) before mounting the bezel to the unit.

## 2 CON·X·US Installation

3. Connect the 24 volt power harness WRE20228/100190832) in series with the 24 volt side of the transformer and the other end of the power harness to the CON·X·US board (see FIG. 2-3).
4. Disconnect the ribbon cable from the rear of the display board and route it to the ribbon cable plug on the CON·X·US board labeled **BIC** (remove the ribbon cable from the clip underneath the bezel).
5. Connect the ribbon cable (WRE20225/WRE20200/100189402) to the rear of the display and route on the left side of the CON·X·US board and connect it to the ribbon cable plug labeled **DU** (see FIG. 2-3).
6. Reinstall the front panel.
7. Turn the power and gas back ON to the unit and resume operation.

**Figure 2-3**\_Wiring Schematic

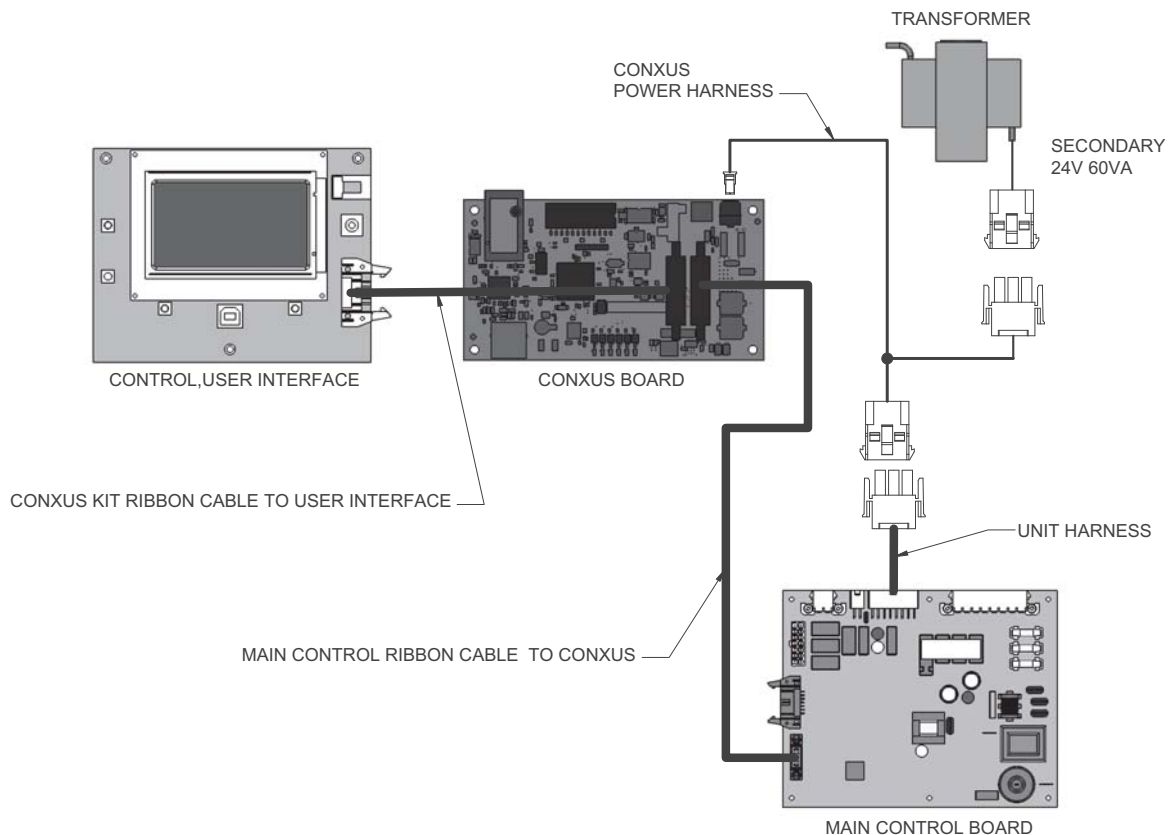

### 3 CON·X·US Registration

**NOTICE**

The screens depicted in this manual are to be used for illustration purposes only.

#### Device Registration

1. Search for the CON·X·US board just like you would search for a Wi-Fi connection on your device. Ensure that your green LED light is ON and that the WLAN LED is OFF.

**NOTICE**

If your CON·X·US board was installed in a boiler prior to this one, you may experience longer wait times for the CON·X·US link to appear.

2. Connect to the device named CON·X·US as shown in FIG. 3-1.

**Figure 3-1**\_Device Connection

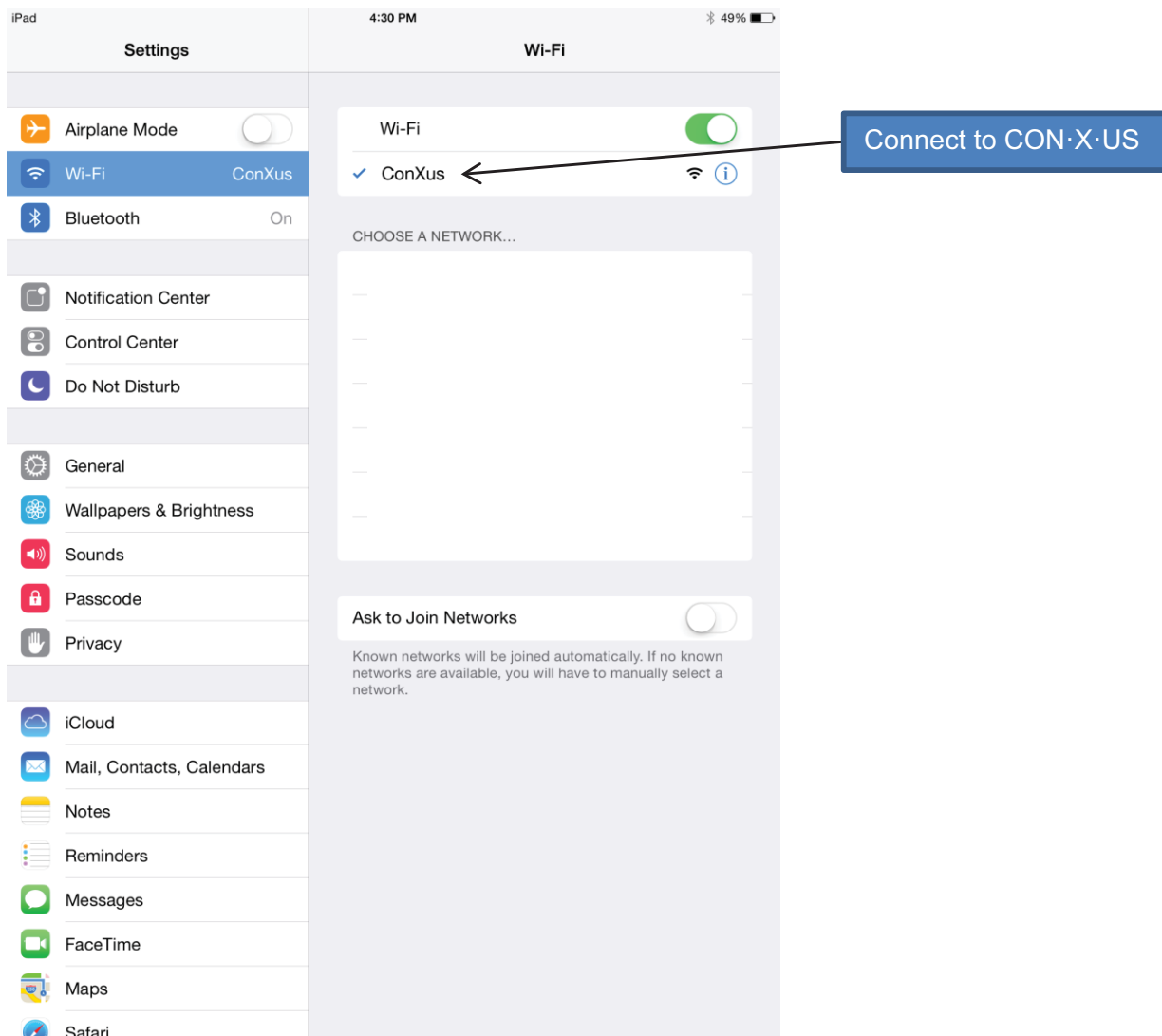

### 3 CON·X·US Registration

- Once connected to the CON·X·US board, you should be redirected to a Login page. Note: If you are not redirected, open your internet browser and type **192.168.0.1** in the address bar and click GO. At this point, you are choosing the network you would like the CON·X·US board to be linked with. If the network is secure you will have to enter in the password for the network.

**Figure 3-2**\_Choose Network

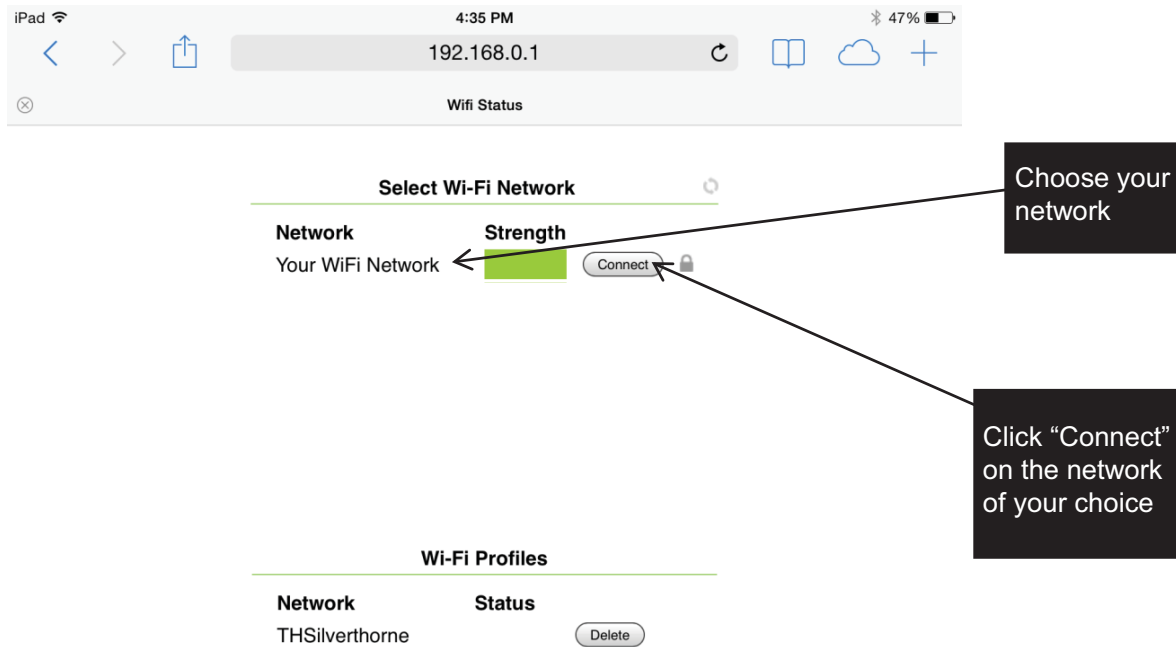

- Enter the security password for your network and click CONNECT.

**Figure 3-3**\_Enter Password

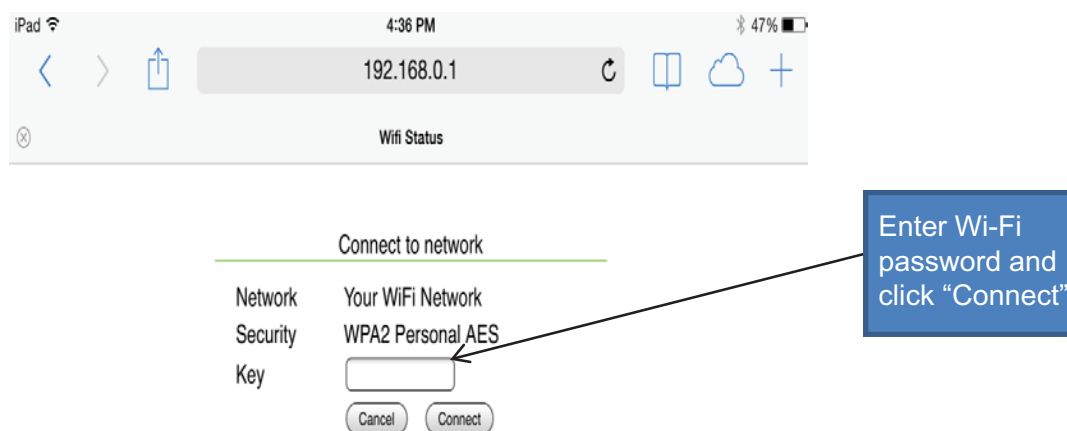

### 3 CON·X·US Registration *(continued)*

5. Your screen should tell you when the WiFi connection is complete. You will also notice a WLAN LED light on the upper left side of the CON·X·US board once the CON·X·US board is connected to your internet source.

**Figure 3-4**\_Connection Complete



6. Download the Android App on Google Play or the Apple App from the App Store.

**NOTICE**

To run the CON·X·US App on your device (Tablet/Phone) you must have a version of iOS 7.0 or above or Android 4.0 or above.

7. Once installation is complete, click on the CON·X·US App (logo) on your Tablet/Phone.

**Figure 3-5**\_Click on App



### 3 CON·X·US Registration

8. If you are a new user you will have to create a new account. If you have an existing account, move on to Step 11.
9. To create a new account, open the CON·X·US App and click CREATE NEW ACCOUNT. You will receive an e-mail asking you to confirm your new account. **NOTE:** Be sure to check your Junk or Spam folders as your new account email may default to one of these folders. You will also be directed to a web page. This web page signifies you have completed the process. Exit the web page and move on to Step 10.

**Figure 3-6**\_Create Account/Login to Existing Account

**Log in**

User Name:

Password:

Save Information

[Create New Account](#) [Login](#)

---

**New User Account**

First Name:  Phone:   Cell

Last Name:  E-Mail:

Company:  Confirm E-Mail:

Address:  Password:

City:  Confirm Password:

State:  Zip:

Country:

[Create](#) [Cancel](#)

10. After creating your account, login to register a CON·X·US board.
11. Once you are logged in you will be directed to the Device Selection Screen. You can now register the unit by clicking on the REGISTER NEW DEVICE button.

**NOTE:** The unit, at some point, must have been connected to the internet before registration can occur.

**Figure 3-7**\_Register New Device Button

**Select Device**

Devices registered under your User Account

Sort by: [Site](#) [Serial Number](#) [City](#)

Boiler Name	Serial Number	Address
<input type="radio"/> Site: University Building: Gym Boiler: 3	L1234567892	123 Main Street Nashville, TN 37216
<input type="radio"/> Site: University Building: Library Boiler: 4	L1234567893	500 Palm Street Nashville, TN 37212
<input type="radio"/> Site: University Building: Dorm Boiler: 7	L2234567895	2345 Burkle Road Nashville, TN 37201
<input type="radio"/> Site: University Building: Hospital Boiler: 17	L4234567897	34 White Street Nashville, TN 37228
<input type="radio"/> Site: University Building: Cafeteria	L2234567898	456 Washington Blvd Nashville, TN 37217

[Register New Device](#) [Log Out](#)

### 3 CON·X·US Registration *(continued)*

12. There are required fields on the Device Registration Screen. Ensure ALL required fields are filled in.

**Figure 3-8**\_Fill in Required Fields

The screenshot shows the "Device Registration" form with the following fields and buttons:

- QR Code on Herald: Required (text input) and Scan (button)
- Barcode on Boiler: Required (text input) and Scan (button)
- Site Name: Required (text input)
- Address: (text input)
- Building/Location: (text input)
- City: Required (text input)
- Boiler Name: (text input)
- State: (dropdown menu)
- Zip: (text input)
- Register (button)
- Cancel (button)

NOTE: You can use the SCAN buttons to fill in the QR code (reference FIG. 1-1 on page 2 for QR Code location) on the CON·X·US board and the serial number of the unit or you can enter them manually.

**Figure 3-9**\_Scan Buttons

This screenshot is identical to Figure 3-8, but includes a blue callout box with the text "Scan buttons for QR code and serial number". Two black arrows point from this box to the "Scan" buttons next to the "QR Code on Herald" and "Barcode on Boiler" fields.

### 3 CON·X·US Registration

13. When you are finished filling in the fields, click the REGISTER button.

Figure 3-10\_Register Button

Device Registration

QR Code on Herald:

Barcode on Boiler:

Site Name:  Address:

Building/Location:  City:

Boiler Name:  State:  Zip:

Register button

14. Once registration has been completed, you will be re-directed to the Device Selection Screen. You are now able to select the unit to monitor and change parameters with the App at this time.

Figure 3-11\_Select Device

Select Device

Devices registered under your User Account

Sort by:

Boiler Name	Serial Number	Address
<input type="radio"/> Site: University Building: Gym Boiler: 3	L1234567892	123 Main Street Nashville, TN 37216
<input type="radio"/> Site: University Building: Library Boiler: 4	L1234567893	500 Palm Street Nashville, TN 37212
<input type="radio"/> Site: University Building: Dorm Boiler: 7	L2234567895	2345 Burkle Road Nashville, TN 37201
<input type="radio"/> Site: University Building: Hospital Boiler: 17	L4234567897	34 White Street Nashville, TN 37228
<input type="radio"/> Site: University Building: Cafeteria	L2234567898	456 Washington Blvd Nashville, TN 37217

Select the job  
you wish to  
view

## 4 Permissions

Whoever registers the CON·X·US will be assigned the role of Site Manager. As you register a CON·X·US your user information will be automatically populated in the site manager field. The Site Manager is responsible for assigning access to users for each site. As the Site Manager your contact information will be displayed in the “Site Manager” field on the “Service Notification” page of the setup tab (see FIG. 4-1).

**Figure 4-1** Site Manager Contact Info

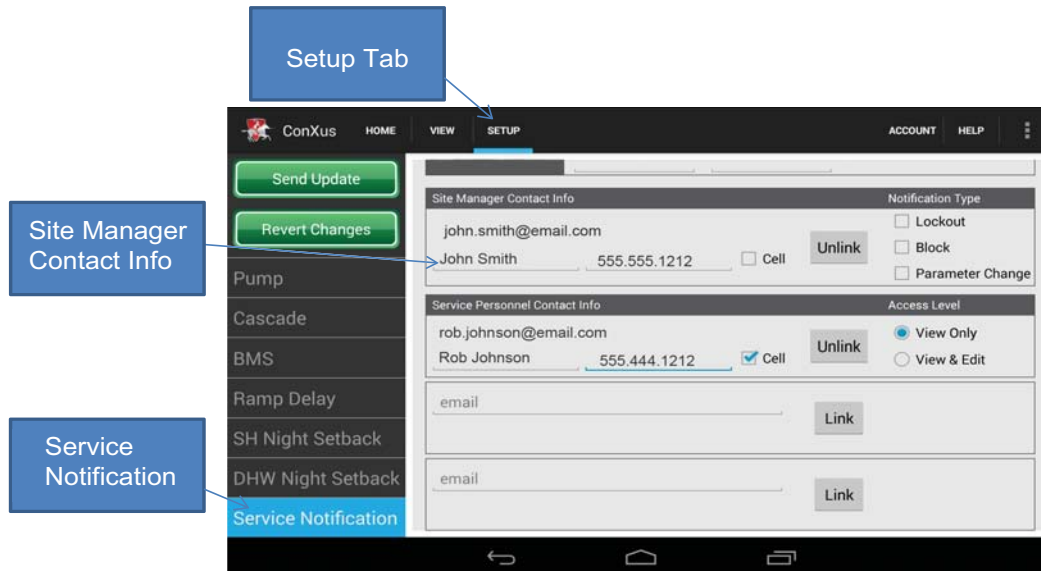

To add a user to a CON·X·US enabled boiler the user will need to create an account (reference the *Create Account* section on page 10 of this manual). Once the user that you wish to add has created an account, the Site Manager must enter the e-mail address into the Service Personnel Contact Info section of the Service Notification Menu and click the LINK button. This will grant access to the CON·X·US enabled boiler and will be populated on the user’s available devices list (reference Select Devices Screen on page 12 of this manual).

NOTE: The UNLINK button can be used to remove a user. If the Site Manager unlinks themselves, the CON·X·US will need to be re-registered.

**Figure 4-2** Enter Contact Information to Add User Access

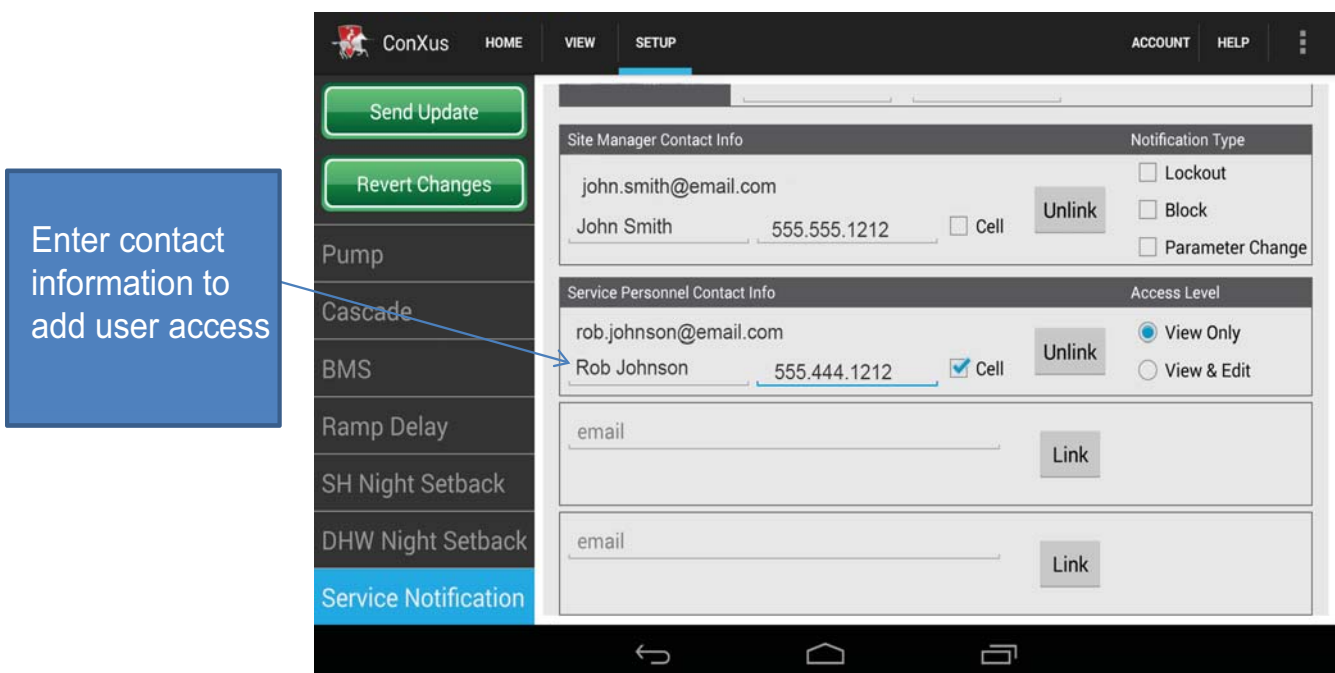

## 4 Permissions

For each service provider, the Site Manager can grant either “View Only” access or “View & Edit” access by clicking one of the boxes to the right of the service provider’s name. “View Only” access will allow that user to view all information without the ability to make any changes. If the Site Manager would like to have a user have “View Only” privileges, but receive alerts, the Site Manager must provide the user with “View & Edit” privileges to allow the user to set up the alerts. Once the setup is complete, the Site Manager can then change that user’s access level back to “View Only”. “View & Edit” access will allow that user to view all information and make programming changes.

**Figure 4-3** Access Levels

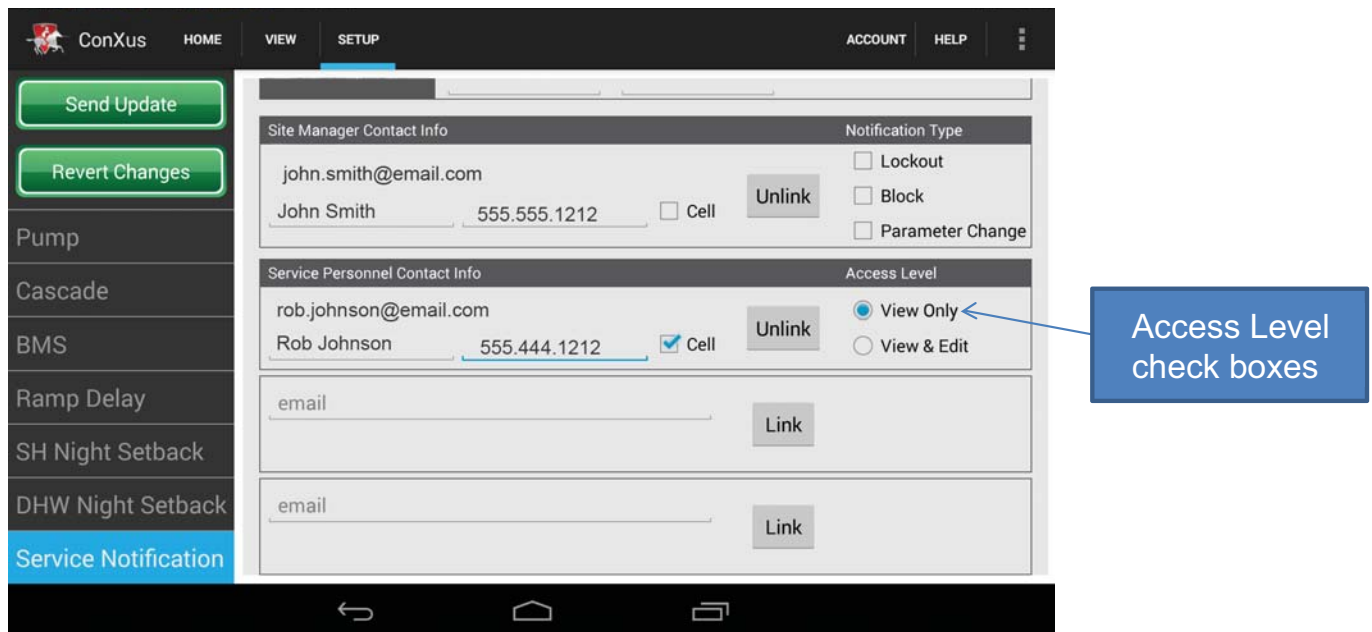

The Site Manager and any user with View & Edit privileges can select which alerts they receive. One, all, or none of these notification types can be selected. By selecting “Lockout” the Site Manager or user will receive a text or e-mail about a lockout condition. Selecting “Block” will result in an e-mail or text message any time the boiler enters a blocking condition. Blocking conditions are not lockouts, but are conditions such as high outlet temperature, high flue temperature, or high Delta T’s, that result in the boiler limiting itself. Blocking conditions can occur often depending on the operation conditions, but could also indicate a problem. Anti-cycling Blockings are not relayed. Selecting “Parameter Change” will result in an e-mail or text message every time a parameter is changed remotely from CON·X·US or locally through the user interface on the boiler.

When a boiler with CON·X·US goes into a fault condition an alert will be sent out via e-mail or text message. A text message will be sent if a cell phone number is entered and the cell box is checked (see FIG. 4-4 on page 15). Otherwise, the user will receive an e-mail.

**NOTE:** Only the Site Manager is able to see all linked personnel. All other personnel will only see the Site Manager.

# 4 Permissions (continued)

Figure 4-4 Enter Cell Phone Info

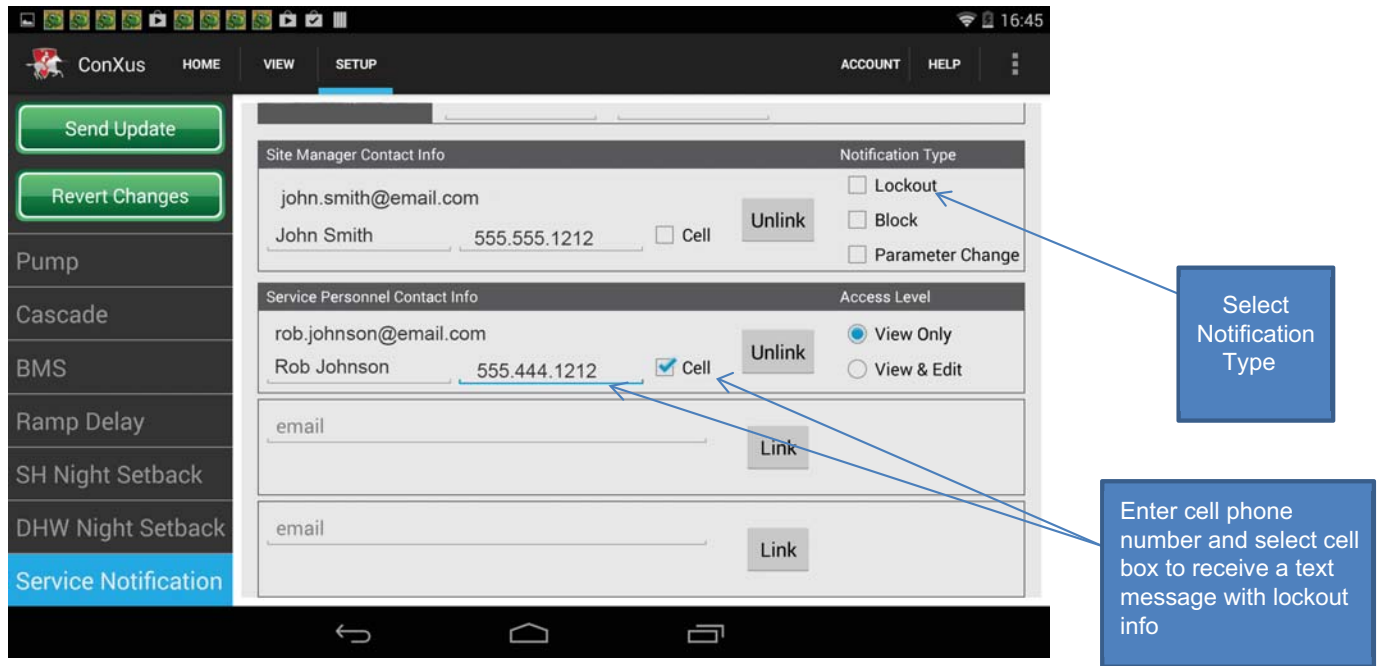
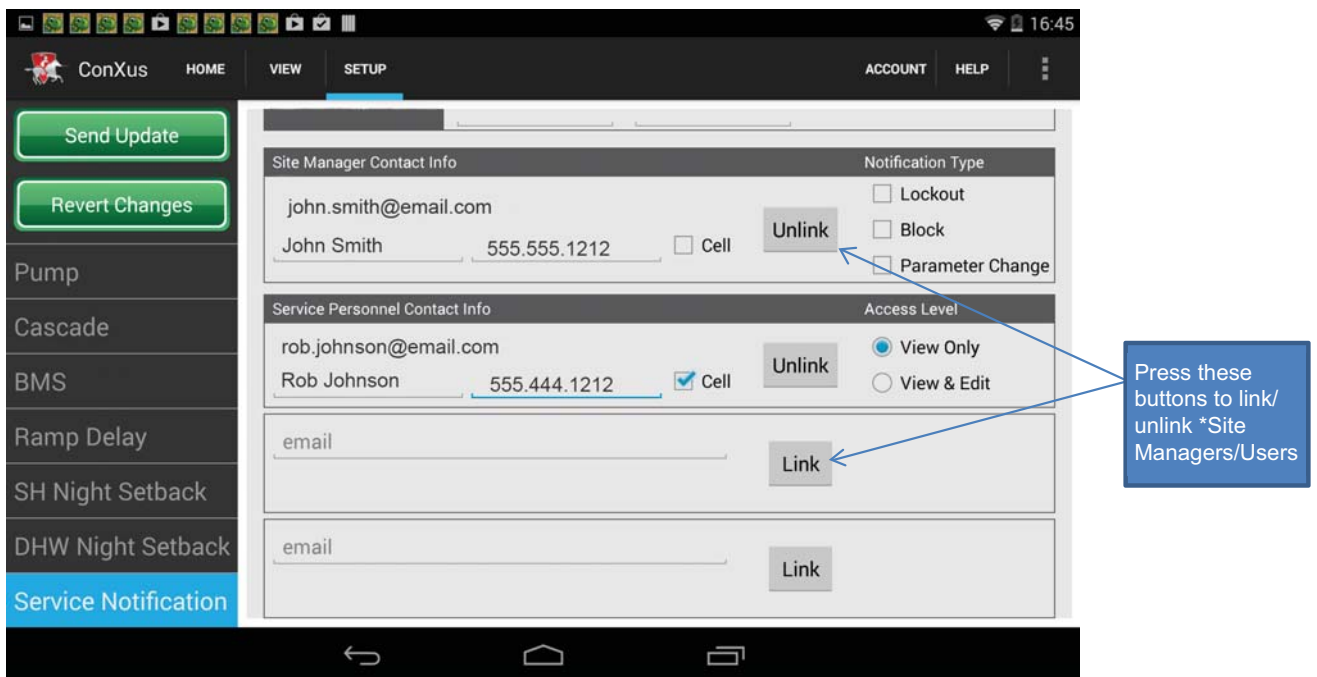

Figure 4-5 Link/Unlink Buttons



\*Site Manager can unlink all if unlinked.

## 4 Permissions

By accessing the Setup tab, the Site Manager and any user with “View and Edit” privileges will be able to make changes to all accessible parameters and send the parameters to the boiler. To send parameters to the boiler simply click the SEND UPDATE button. The REVERT CHANGES button will retrieve the last saved parameters and re-populate all the screens with those parameters.

**Figure 4-6** Send New Parameters to Boiler

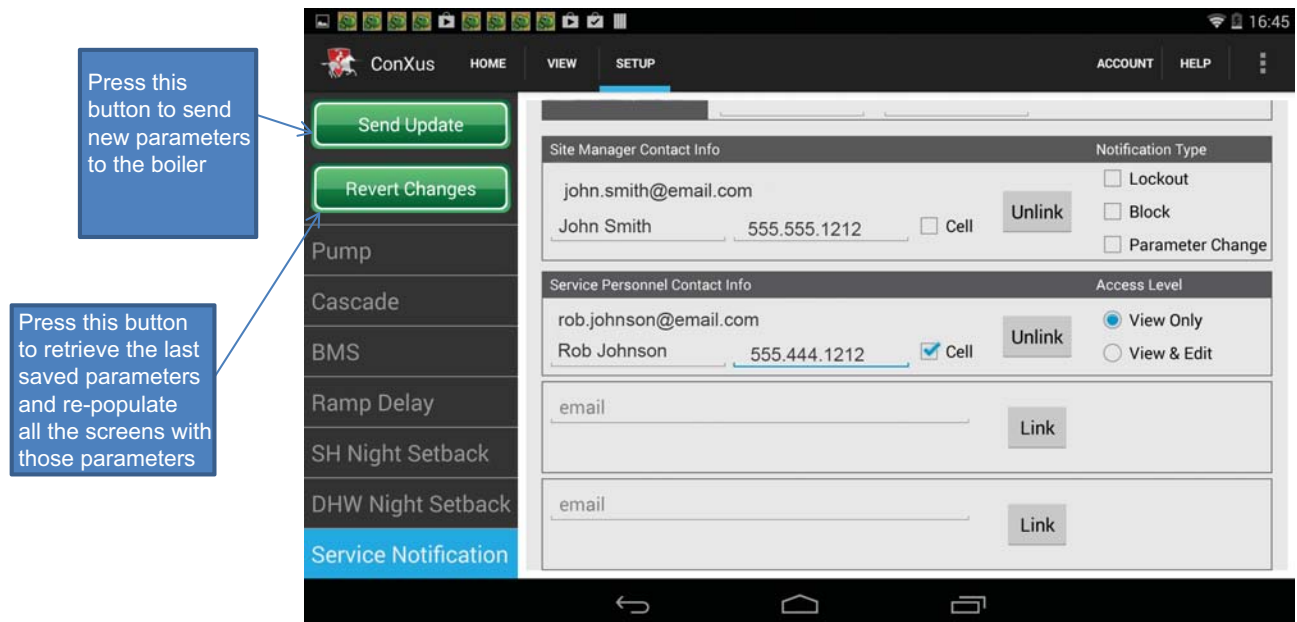

## 4 Permissions *(continued)*

### How to use the sort function

By clicking on the ACCOUNT button you will be taken to a list of all the boilers registered to the Account Manager or user. You can access any boiler on the list by selecting the desired boiler. The sort function can be used to sort the list of boilers by serial number, city, or site name.

If a boiler is gray, this means it is not communicating with the internet. This could mean that the boiler is powered OFF or that the CON-X-US module is not connected to the internet.

**Figure 4-7** Sort Function

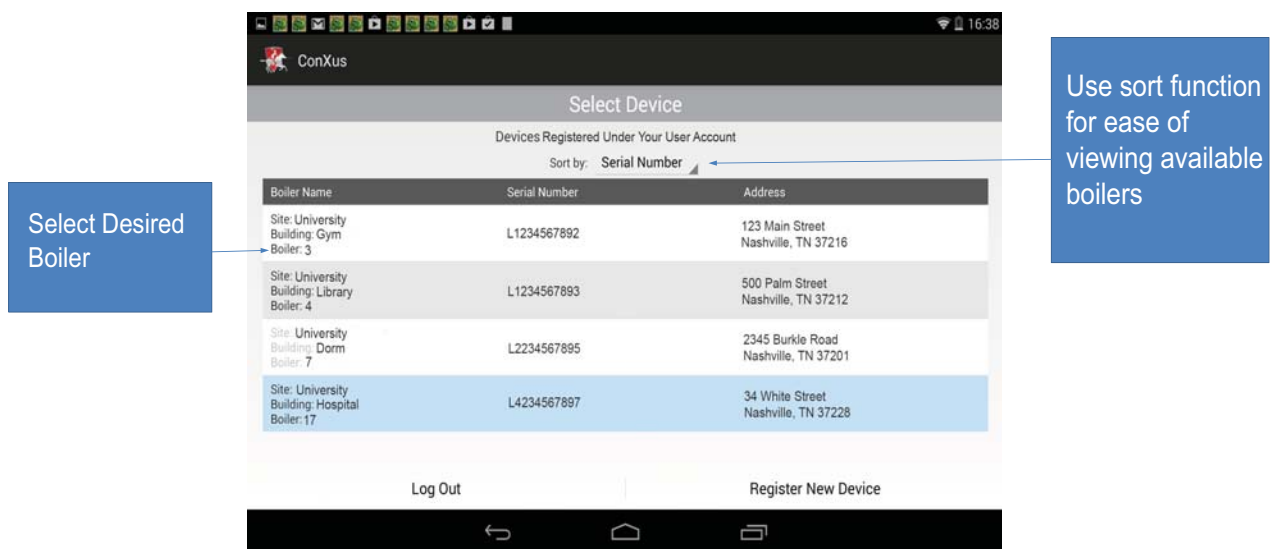

# 5 Troubleshooting

**Figure 5-1**\_CON·X·US LED Layout

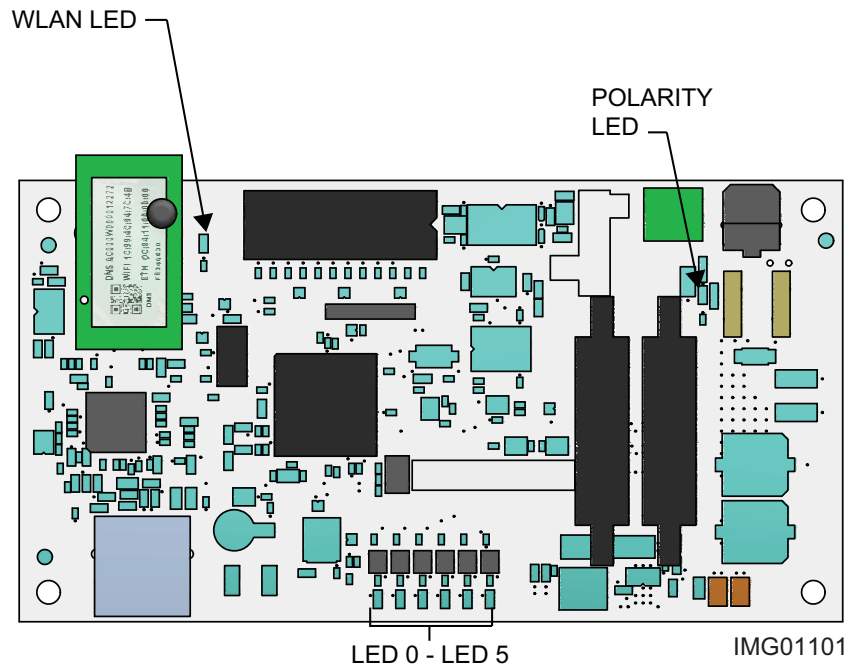

**Table 5-1** CON·X·US LED Troubleshooting Table

LED	DESCRIPTION	ERROR	CORRECTIVE ACTION
LED 0	N/A	--	--
LED 1	Control to Display Communication Error	RED	<ul style="list-style-type: none"> <li>• Check ribbon cable connections and display.</li> </ul>
LED 2	CON·X·US Communication	BLANK	<ul style="list-style-type: none"> <li>• If blank during known transfer through CON·X·US, review install and registration.</li> </ul>
LED 3	N/A	--	--
LED 4	Control to Display Communication	BLANK	<ul style="list-style-type: none"> <li>• No display signal received, check ribbon cable connections.</li> </ul>
LED 5	Power Confirmation	BLANK	<ul style="list-style-type: none"> <li>• Confirm power on 24 VAC supply from transformer.</li> </ul>
WLAN	Internet Connectivity Confirmation	BLANK	<ul style="list-style-type: none"> <li>• If after registration, repeat section of set-up.</li> </ul>
POLARITY	Inverse Polarity Alert	RED	<ul style="list-style-type: none"> <li>• Swap 24 VAC power and ground.</li> </ul>



This device complies with Part 15 of the FCC Rules. Operation is subject to the following two conditions:  
(1) This device may not cause harmful interference. (2) This device must accept any interference received including interference that may cause undesired operation.

This Class A digital apparatus complies with Canadian ICES-003.  
Cet appareil numérique de la classe A est conforme à la norme NMB-003 du Canada.