

PURE PERFORMANCE[™]

COMMERCIAL HRV

OPERATION AND INSTALLATION

455FD/DD, 650FD/DD, 700FD/DD , 1200FD/DD

69-COMHRV 011118



511 McCormick Blvd.
London, ON
Canada
N5W 4C8

General Info/Tech Support:
1 855. 247 4200

Online:
www.lifebreath.com

Table of Contents

The Benefits of HRVs		Optional Wireless Timer	16-17
Location of the HRV for Mounting	3	Optional Wireless Repeater	
Specifications - Model 455FD/DD	4	Optional Timer	18
Specifications - Model 700FD/DD	5	Function And Controls	19
Specifications - Model 650FD/DD	6	Connecting Optional Digital Controls	20-21
Specifications - Model 1200FD/DD	7	Balancing the HRV	22
The Ductwork System		Service and Maintenance	23-24
Outside Weatherhoods	8	Reverse Installation	25-26
Stale Air Return System		Aircon Relays	27
Fresh Air Supply System		Troubleshooting your HRV System	28
Adjustable Grilles	9	Wiring Diagrams	29-32
The Integrated HVAC System	10	Warranty	33
Drain Connections			
Electrical Connections	11		
HRV Defrost Strategies			
Defrost Time Adjustment	12		
Reversing the Supply and Defrost Air Ports ...	13		
Optional Ventilation Control			
Optional 3 Speed Control	14		
Optional Dehumidistat	15		

⚠ CAUTION

Assess how the operation of an HRV may interact with already installed vented combustion equipment (ie. Gas Furnaces, Oil Furnaces, Wood Stoves, etc.).

⚠ ATTENTION

Do not apply electrical power to the unit until installation has been fully completed (including low voltage control wiring).

⚠ CAUTION

Never install an HRV in a situation where its normal operation, lack of operation or partial failure may result in the backdrafting or improper functioning of vented combustion equipment!

Leave this manual with your customer!

TO BE COMPLETED BY CONTRACTOR AFTER INSTALLATION

Installing Contractor

Telephone / Contact

Serial Number

Installation Date Model

The Benefits of HRVs

Heat Recovery Ventilators (HRV) are designed to supply fresh air to a building while exhausting an equal amount of stale air from the building. An energy savings is experienced during the process by reducing the heating (or cooling) requirements.

HRV - Aluminum Core

During the winter months, the incoming cold fresh air is warmed by utilizing the heat recovered from the stale air before it is exhausted to the outdoors. During summer months when the indoor space is air conditioned, the Heat Recovery Ventilator will help in cooling the incoming fresh air with the stale air that is being exhausted.

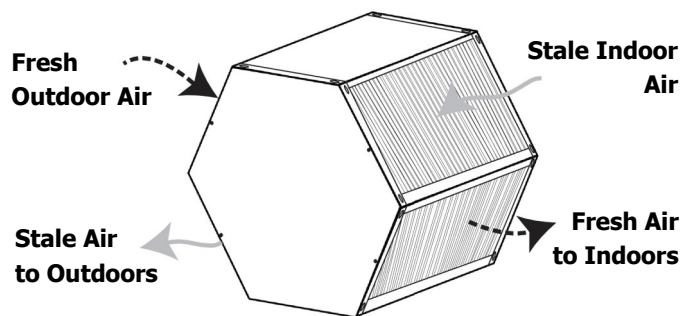

Location of the HRV for Mounting

The HRV must be located in a heated space where the surrounding air temperature does not fall below 60°F (16°C). The unit must be mounted level (horizontal) to obtain proper drainage of water from the heat exchange element and drip pans. The warranty will be void if these conditions are not met.

Typically, the HRV is positioned close to an outside wall or the roof to simplify the connections and keep the length of insulated ducting required for the fresh air intake to a minimum.

A minimum clearance of 30 inches (76 cm) in front of the HRV is recommended to service the heat exchanger cores and the filters. The HRV may be mounted on an equipment platform providing the drain hoses are clear and there is sufficient space to open the doors for servicing.

Saddle Installation

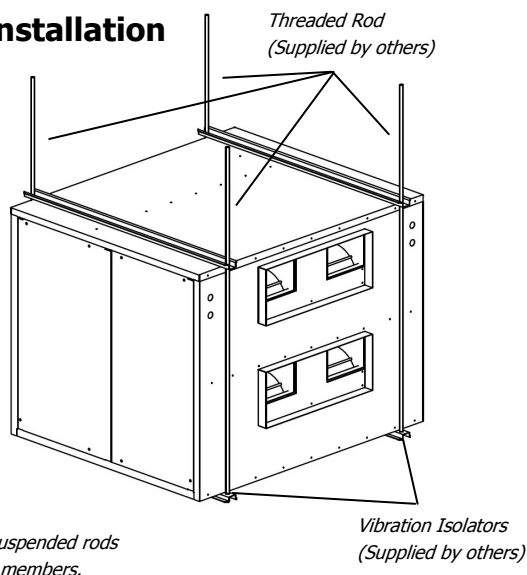

Curb Mounted

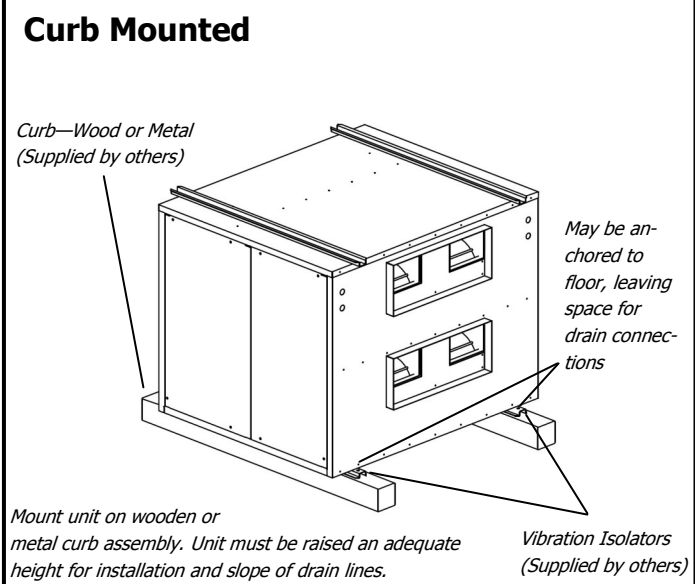

! ATTENTION

Flexible duct connectors should be installed between the HRV and the galvanized ductwork.



CORES
Modular (2 section) patented aluminum heat recovery cores arranged for efficient counter-flow ventilation.

MOTORS
Two PSC, 3 speed single shafted, 120 VAC, 1.92 Amps each (3.8 total on high speed). HP- 1/6, 1625 RPM. MCA: 4.8 MOP: 15. Watts - total on high speed - 437.

FILTERS
Washable air filters in exhaust and supply air streams.

BLOWERS
Slide easily in / out of unit. Centrifugal type rated at 236 L/s (500 CFM) free air delivery. Each air stream has one single shafted motor driving a centrifugal blower.

CONNECTION DUCT SIZES
Four - 14" x 8" (356 mm x 200 mm).

MOUNTING
Unit to be set on support brackets hung by threaded rod type apparatus (brackets and rods not provided).

CASE
Unit has front and back access doors and electrical panel can be switched to either side giving the installer flexibility in duct direction. 20 gauge pre-painted galvanized steel (G60) for superior corrosion resistance. Insulated with foil faced insulation where required to prevent exterior condensation. Drain connections; two - 1/2" (12 mm) O.D.

ELECTRONICS
Integrated microprocessor circuit board. Built-in interlock contacts.

DEFROST CONTROLS
MODEL 455FD - Interrupts supply air while exhaust air defrosts core.
MODEL 455DD - Supply bypass routes indoor air to defrost core.

WEIGHT 150 lbs. (70 kg) **SHIPPING WEIGHT** 210 lbs. (90 kg)

CONTROL OPTIONS

99-BC02 Lifebreath Ventilation Control

- 2 speed fan setting (Low/High)
- Humidity control through adjustable Dehumidistat
- Compatible with 99-DET02 Wireless Timers
- 3 wire connection; 20 gauge wire (minimum)

99-500 3 Speed Control

- 3 Speed Fan setting (Low/Medium/High)
- 4 wire connection; 20 gauge wire (minimum)

99-DH01 Lifebreath Dehumidistat

- Humidity control through adjustable Dehumidistat
- 3 wire connection; 20 gauge wire (minimum)

DIMENSIONS inches (mm)

NOTE: The 455FD/DD model may easily be reversed in the field. Refer to page 25 for installation instructions.

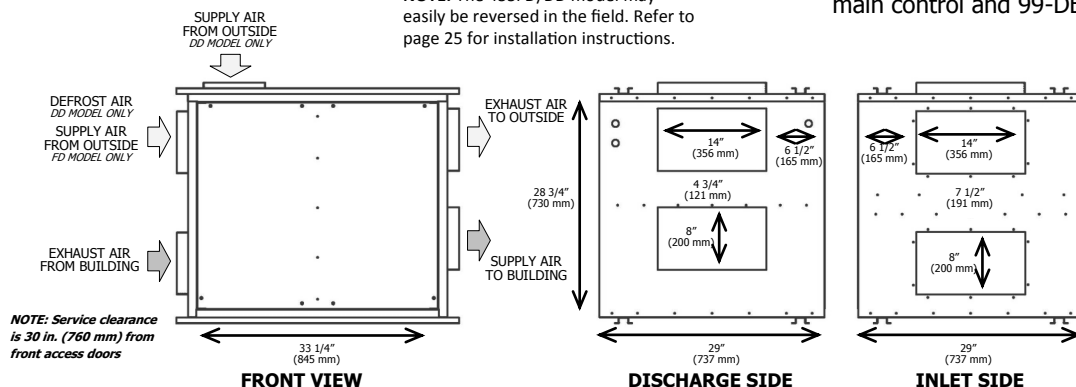

PERFORMANCE

AIRFLOWS (Each Air Stream)

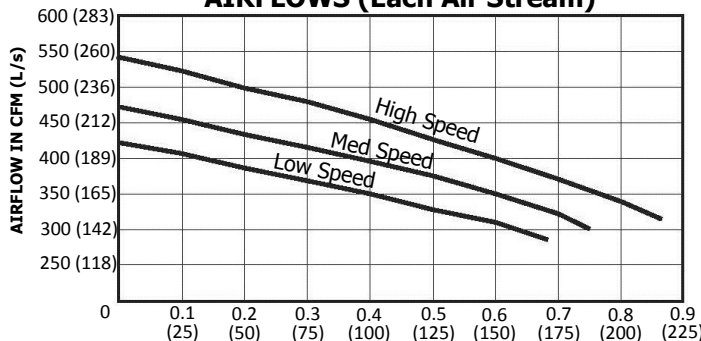

TEMPERATURE EFFECTIVENESS

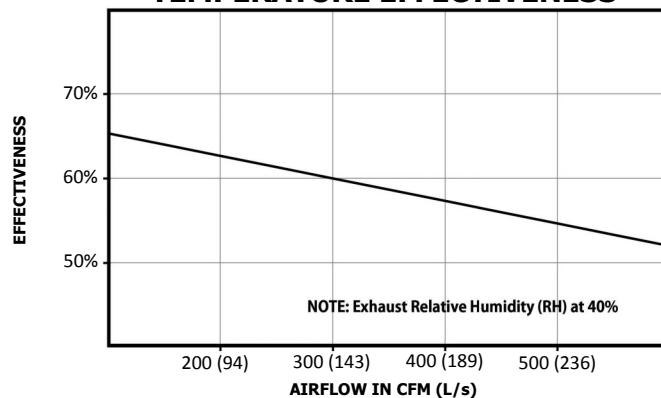

AHRI 1060 Certified
Core: Contains two 68-222

TIMER OPTIONS

99-DET01 Lifebreath 20/40/60 Minute Timer

- Initiates high speed Ventilation for 20, 40 or 60 minutes
- 3 wire connection; 20 gauge wire (minimum)

99-DET02 Lifebreath WIRELESS 20/40/60 Minute Timer

- Initiates high speed Ventilation for 20, 40 or 60 minutes
- Wirelessly connects to main control for ease of installation
- 40' approximate range

99-RX02 Lifebreath WIRELESS Repeater

- Used to extend range of 99-DET02 Wireless Timers when Timers are out of range
- Plugs into 120V power outlet and wirelessly connects to main control and 99-DET02

WARRANTY

Units carry a 15 year warranty on the HRV core and a 2 year replacement parts warranty.

All units conform to CSA and UL standards

NOTE: All specifications are subject to change without notice.

Date: _____

Tag: _____ Qty: _____

Project: _____

Engineer: _____

Contractor: _____

Supplier: _____

Quote #: _____

Submitted by: _____



CORES
Modular (2 section) patented aluminum heat recovery cores arranged for efficient counter-flow ventilation.

MOTORS
Two PSC, 3 speed single shafted, 120 VAC, 4.5 Amps each (9 total on high speed). HP-1/4, 1450 RPM. MCA: 11.3 MOP: 15 Watts - total on high speed - 1032.

FILTERS
Washable air filters in exhaust and supply air streams.

BLOWERS
Slide easily in / out of unit. Centrifugal type rated at 700 CFM (329 L/s) free air delivery. Each air stream has one single shafted motor driving a centrifugal blower.

CONNECTION DUCT SIZES - Four - 14" x 8" (356 mm x 200 mm).

MOUNTING
Unit to be set on support brackets hung by threaded rod type apparatus (brackets and rods not provided).

CASE
Unit has front and back access doors and electrical panel can be switched to either side giving the installer flexibility in duct direction. 20 gauge pre-painted galvanized steel (G60) for superior corrosion resistance. Insulated with foil faced insulation where required to prevent exterior condensation. Drain connections are two - 1/2" (12 mm) O.D.

ELECTRONICS
Integrated microprocessor circuit board. Built-in interlock contacts.

DEFROST CONTROLS
MODEL 700FD - Interrupts supply air while exhaust air defrosts core.
MODEL 700DD - Supply bypass routes indoor air to defrost core.

WEIGHT 260 LBS (118 KG) **SHIPPING WEIGHT** 310 LBS. (141 KG)

CONTROL OPTIONS

99-BC02 Lifebreath Ventilation Control

- 2 speed fan setting (Low/High)
- Humidity control through adjustable Dehumidistat
- Compatible with 99-DET02 Wireless Timers
- 3 wire connection; 20 gauge wire (minimum)

99-500 3 Speed Control

- 3 Speed Fan setting (Low/Medium/High)
- 4 wire connection; 20 gauge wire (minimum)

99-DH01 Lifebreath Dehumidistat

- Humidity control through adjustable Dehumidistat
- 3 wire connection; 20 gauge wire (minimum)

DIMENSIONS inches (mm)

NOTE: The 700FD/DD model may easily be reversed in the field. Refer to page 25 for installation instructions.

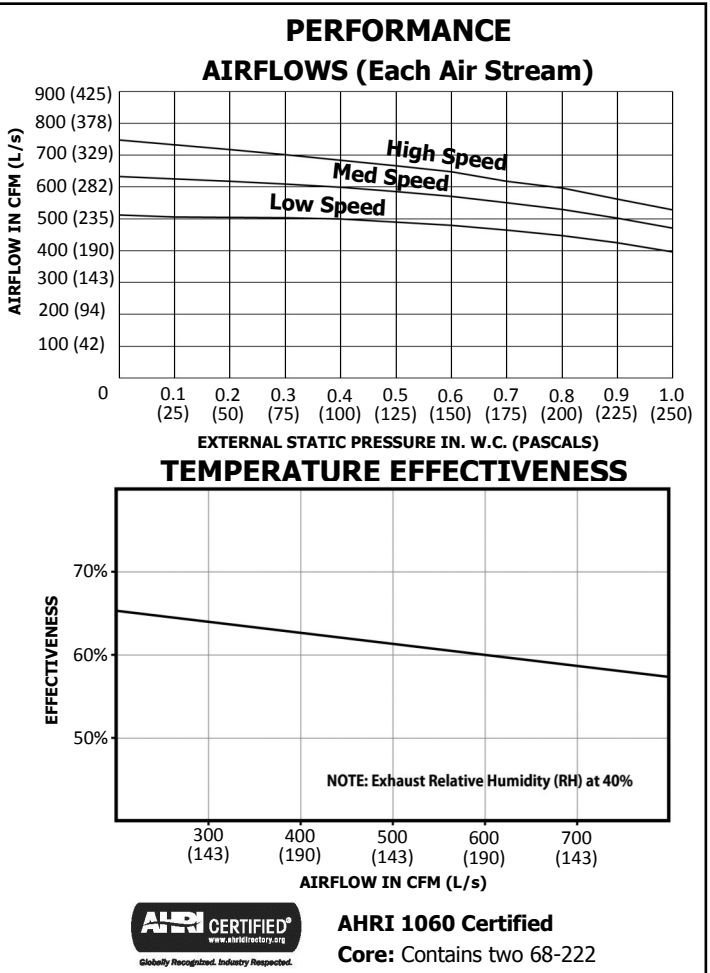
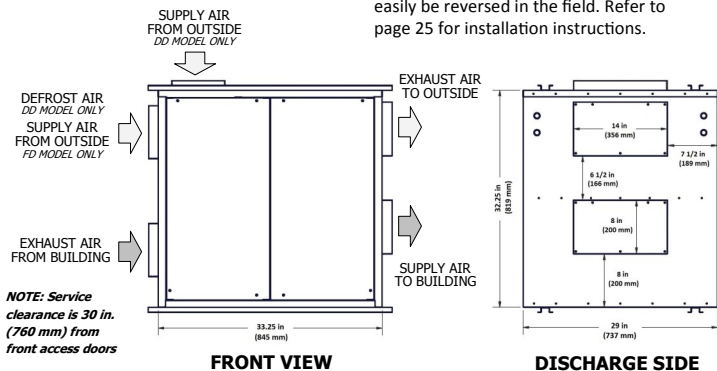

TIMER OPTIONS

99-DET01 Lifebreath 20/40/60 Minute Timer

- Initiates high speed Ventilation for 20, 40 or 60 minutes
- 3 wire connection; 20 gauge wire (minimum)

99-DET02 Lifebreath WIRELESS 20/40/60 Minute Timer

- Initiates high speed Ventilation for 20, 40 or 60 minutes
- Wirelessly connects to main control for ease of installation
- 40' approximate range

99-RX02 Lifebreath WIRELESS Repeater

- Used to extend range of 99-DET02 Wireless Timers when Timers are out of range
- Plugs into 120V power outlet and wirelessly connects to main control and 99-DET02

FILTER OPTION

99-65-183 2" pleated MERV 8 filter for fresh air stream

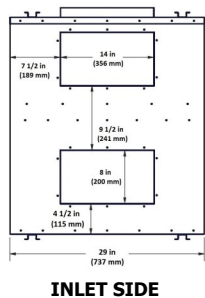

WARRANTY
Units carry a 15 year warranty on the HRV core and a 2 year replacement parts warranty.

All units conform to CSA and UL standards
NOTE: All specifications are subject to change without notice.

Date: _____

Tag: _____ Qty: _____

Project: _____

Engineer: _____

Contractor: _____

Supplier: _____

Quote #: _____

Submitted by: _____



CORES

Modular (6 section) patented aluminum heat recovery cores arranged for high efficiency counter-flow ventilation.

MOTORS

Two PSC, 3 speed double shafted, 120 VAC, 3.8 Amps each (7.6 total on high speed). HP - 1/4, 1625 RPM. Watts - total on High Speed - 912. MCA: 9.5 MOP: 15

FILTERS

Washable air filters in exhaust and supply air streams.

BLOWERS

Slide easily in / out of unit. Centrifugal type rated at 850 cfm (401 L/s) free air delivery. Each air stream has one double shafted motor driving two centrifugal blowers.

CONNECTION DUCT SIZES

Four - 20" x 8" (508 mm x 200 mm). Model 650DD - additional 20" X 8" defrost port

MOUNTING

Unit to be set on support brackets hung by threaded rod type apparatus (brackets and rods not provided).

CASE

Unit has front and back access doors and electrical panel can be switched to either side giving the installer flexibility in duct direction. 20 gauge pre-painted galvanized steel (G60) for superior corrosion resistance. Insulated with foil faced insulation where required to prevent exterior condensation. Drain connection is one - 1/2" (12 mm) O.D.

ELECTRONICS

Integrated microprocessor circuit board. Built-in interlock contacts.

DEFROST CONTROLS

Model 650FD - Interrupts supply air while exhaust air defrosts core.
Model 650DD - Supply bypass routes indoor air to defrost core.

WEIGHT 270 lbs. (120 kg) **SHIPPING WEIGHT** 350 lbs. (156 kg)

CONTROL OPTIONS

99-BC02 Lifebreath Ventilation Control

- 2 speed fan setting (Low/High)
- Humidity control through adjustable Dehumidistat
- Compatible with 99-DET02 Wireless Timers
- 3 wire connection; 20 gauge wire (minimum)

99-500 3 Speed Control

- 3 Speed Fan setting (Low/Medium/High)
- 4 wire connection; 20 gauge wire (minimum)

99-DH01 Lifebreath Dehumidistat

- Humidity control through adjustable Dehumidistat
- 3 wire connection; 20 gauge wire (minimum)

DIMENSIONS inches (mm)

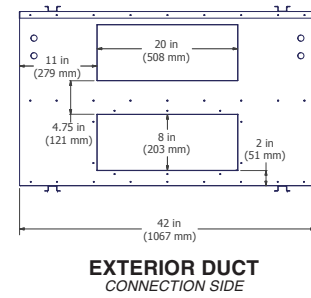
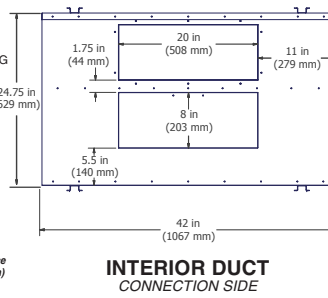
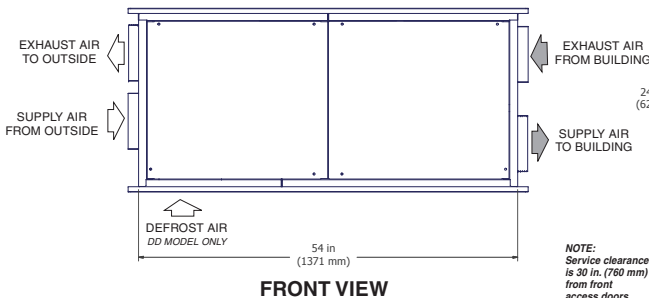

WARRANTY
Units carry a 15 year warranty on the HRV core and a 2 year replacement parts warranty.

NOTE: The 650FD/DD model may easily be reversed in the field. Refer to page 25 for installation instructions.
All units conform to CSA and UL standards

NOTE: All specifications are subject to change without notice.

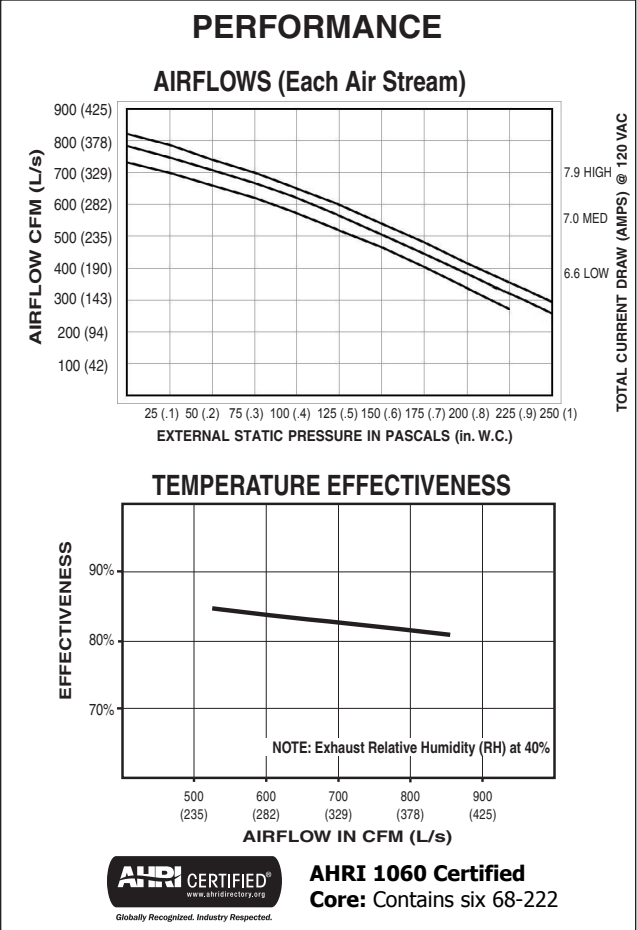

TIMER OPTIONS

99-DET01 Lifebreath 20/40/60 Minute Timer

- Initiates high speed Ventilation for 20, 40 or 60 minutes
- 3 wire connection; 20 gauge wire (minimum)

99-DET02 Lifebreath WIRELESS 20/40/60 Minute Timer

- Initiates high speed Ventilation for 20, 40 or 60 minutes
- Wirelessly connects to main control for ease of installation
- 40' approximate range

99-RX02 Lifebreath WIRELESS Repeater

- Used to extend range of 99-DET02 Wireless Timers when Timers are out of range
- Plugs into 120V power outlet and wirelessly connects to main control and 99-DET02

FILTER OPTIONS

99-65-183 2" pleated MERV 8 filter for fresh air stream

Date: _____
 Tag: _____ Qty: _____
 Project: _____
 Engineer: _____

Contractor: _____
 Supplier: _____
 Quote#: _____
 Submitted by: _____



CORES
Modular (3 section) patented aluminum heat recovery cores arranged for efficient counter-flow ventilation.

MOTORS
Two PSC, 3 speed double shafted, 120 VAC, 9.4 Amps each (18.8 total on high speed). HP - 1/2, 1625 RPM. Watts - total on high speed - 2256. MCA: 23.5 MOP: 30

FILTERS
Washable air filters in exhaust and supply air streams.

BLOWERS
Slide easily in / out of unit. Centrifugal type rated at 1200 cfm (566 L/s) free air delivery. Each air stream has one double shafted motor driving 2 centrifugal blowers.

CONNECTION DUCT SIZES
Four - 20" x 8" (508 mm x 200 mm).

MOUNTING
Unit to be set on support brackets hung by threaded rod type apparatus (brackets and rod not provided).

CASE
Unit has front and back access doors and electrical panel can be switched to either side giving the installer flexibility in duct direction. 20 gauge pre-painted galvanized steel (G60) for superior corrosion resistance. Insulated with foil faced insulation where required to prevent exterior condensation. Drain connections; two - 1/2" (12 mm) O.D.

ELECTRONICS
Integrated microprocessor circuit board. Built-in interlock contacts. Optional remote speed control.

DEFROST CONTROLS
MODEL 1200FD - Interrupts supply air while exhaust air defrosts core.
MODEL 1200DD - Supply bypass routes indoor air to defrost core.

WEIGHT 285 LBS (130 KG) **SHIPPING WEIGHT** 335 LBS. (152 KG)

CONTROL OPTIONS

- 99-BC02 Lifebreath Ventilation Control**
 - 2 speed fan setting (Low/High)
 - Humidity control through adjustable Dehumidistat
 - Compatible with 99-DET02 Wireless Timers
 - 3 wire connection; 20 gauge wire (minimum)
- 99-500 3 Speed Control**
 - 3 Speed Fan setting (Low/Medium/High)
 - 4 wire connection; 20 gauge wire (minimum)
- 99-DH01 Lifebreath Dehumidistat**
 - Humidity control through adjustable Dehumidistat
 - 3 wire connection; 20 gauge wire (minimum)

DIMENSIONS inches (mm)

NOTE: The 1200FD/DD model may easily be reversed in the field. Refer to page 25 for installation instructions.

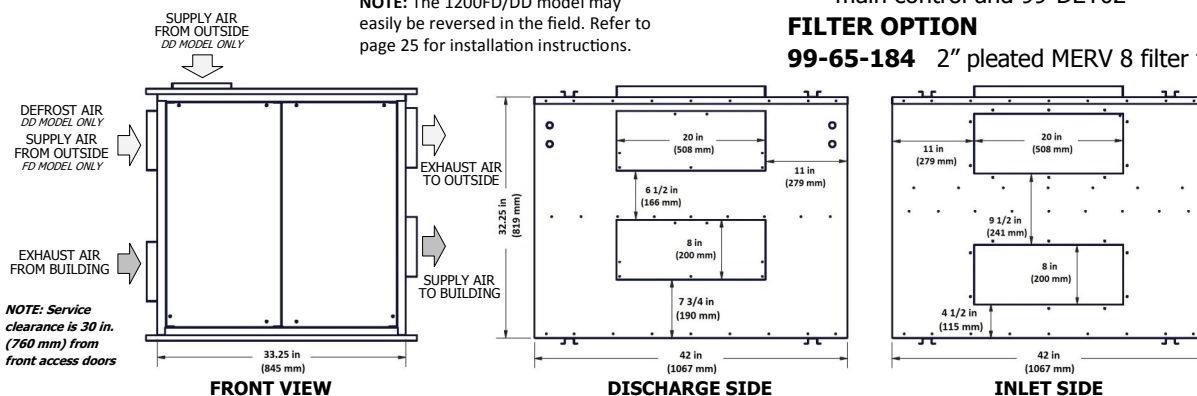

Date: _____
 Tag: _____ Qty: _____
 Project: _____
 Engineer: _____

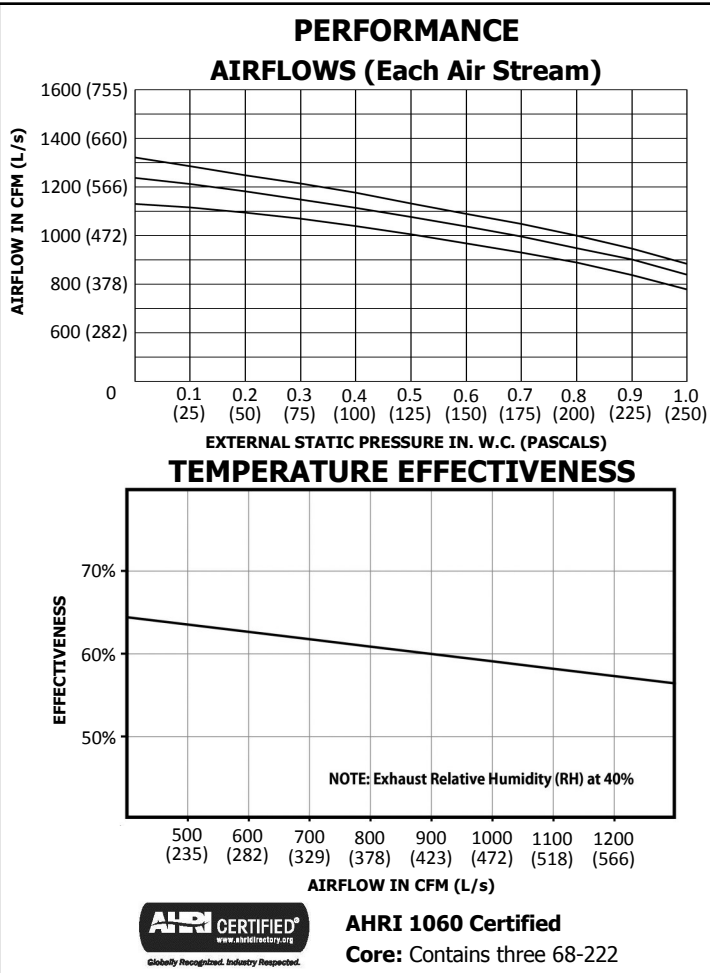

- TIMER OPTIONS**
- 99-DET01 Lifebreath 20/40/60 Minute Timer**
 - Initiates high speed Ventilation for 20, 40 or 60 minutes
 - 3 wire connection; 20 gauge wire (minimum)
 - 99-DET02 Lifebreath WIRELESS 20/40/60 Minute Timer**
 - Initiates high speed Ventilation for 20, 40 or 60 minutes
 - Wirelessly connects to main control for ease of installation
 - 40' approximate range
 - 99-RX02 Lifebreath WIRELESS Repeater**
 - Used to extend range of 99-DET02 Wireless Timers when Timers are out of range
 - Plugs into 120V power outlet and wirelessly connects to main control and 99-DET02
- FILTER OPTION**
99-65-184 2" pleated MERV 8 filter for fresh air stream

WARRANTY
Units carry a 15 year warranty on the HRV core and a 2 year replacement parts warranty.

All units conform to CSA and UL standards
NOTE: All specifications are subject to change without notice.

Contractor: _____
 Supplier: _____
 Quote #: _____
 Submitted by: _____

The Ductwork System

A properly designed ducting system will allow the HRV to operate at its maximum efficiency. (Air flow will be restricted by undersized ducting, use of too many elbows, tees, bends, etc.). Always try to keep duct runs as short and straight as possible.

NOTE: Fully insulated ducting with an integral vapor barrier must be used on all runs passing through unheated areas in order to avoid condensation problems and energy losses from the air streams.

All joints must be airtight, sealed and impervious to moisture. See specification sheets for each unit for exact duct sizes and location.

To minimize pressure drop and noise, galvanized metal ducts, properly sized, are recommended. Keep ducting as short as possible and use a minimum of elbows and tees.

Connecting sections and shorter runs may be flexible ducting one size larger than the metal equivalent. Use flexible duct connectors at the HRV to avoid noise transmission.

All duct joints must be secured with screws, rivets or duct sealant and sealed with aluminum duct tape to prevent leakage.

ATTENTION

Fully insulated ducting with an integral vapour barrier must be used on all runs passing through unheated areas in order to avoid condensation problems and energy losses from the air systems.

Outside Weatherhoods

The weatherhoods must have built-in "bird" screen with 1/4 in (6.35 mm) minimum mesh to prevent birds and rodents from entering into the ductwork. **Do not** use smaller mesh as it will be very susceptible to plugging up. Gravity dampers at the vents must not be used as they will restrict air flow and often "seize up". The preferred location of the outside weatherhoods is:

- no less than 10 ft. (3 m) apart from each other
- at least 18 in (46 cm) above snow line or ground level
- away from sources of contaminants, such as automobile exhaust fumes, gas meters, garbage cans, containers, etc.
- not exposed to prevailing winds

The outside perimeter of the weatherhood must be caulked to prevent leakage into the building.

The design and size of the weatherhoods or louvers chosen by the installer must allow for adequate free area. Water and debris penetration of the system is minimized when the airflow does not exceed 1000 FPM (5.08 m/s) free area velocity.

Ducting from the Weatherhoods

Galvanized sheet metal ducting with sufficient cross section with an integral single piece vapor barrier should be used to connect the HRV to the weatherhoods. **All ducting must meet UL Class 1 requirements.**

A minimum R value of insulation should be equal to 4 (RSI 0.75)

A good bead of high quality caulking (preferably acoustical sealant) and taping with a high quality aluminum foil tape is recommended to seal the duct to both the HRV and the weatherhood.

Stale Air Return System

The stale air return system is used to draw air from the points in the building where the worst air quality problems occur. Balancing dampers and/or adjustable grilles are recommended on all return air lines which are used during installation to help balance the "draw" from different areas of the building.

Alternately, the stale air may be drawn directly from the return air duct. When this system is used, the air handler's blower must constantly operate. The exhaust take-off connection must be at least 3 ft (1 m) from a directly connected HRV supply duct if both are connected to the same duct run. Note and compensate for the static pressure of the air handlers return system if the static pressure of the return in the air handler exceeds .1 to .15" W.C.

A damper located just prior to the HRV is required to balance the stale air exhausted with the fresh air supply entering the building.

Return air suction points should be located on the opposite side of the room from the fresh air inlet.

The inlets may be located in the ceiling or high on the walls and fitted with inlet grilles.

Many commercial activities produce air contaminants in the form of dusts, fumes, mists, vapors and gases. Contaminants should be controlled at the source so they are not dispersed through the building or allowed to increase to toxic concentration levels. The ventilator allows for economical operation of the HVAC system while effectively removing contaminants from the space. In designing the exhaust portion of the system the exhaust grilles are situated to remove the contaminants while not allowing them to enter the breathing zone of the occupants.

For contaminants lighter than air, grilles should be located high on the wall. If contaminants are heavier than air, a lower placement of the grilles will be required. Information on a contaminants specific gravity and toxicity should be available from chemical data sheets.

Fresh Air Supply System

The fresh air supply ductwork from the HRV may be directly connected to the return air duct of the forced air system. Check the air flow balance of the HRV with the air handler blower both "ON" and "OFF" to determine that it does not imbalance the HRV more than 10%. Also, it is advisable to include a short length of flex duct or other non-metallic connector in this hard ducted line in order to keep the HRV acoustically isolated and separately grounded (electrically) from the air handler. This will avoid a possible shock hazard to service people if a short to ground develops in one of the devices.

It may be necessary to install a separate fresh air supply ductwork system if the heating is other than forced air.

When installing an HRV, the designer and installer should be aware of local codes that may require smoke detectors and/or firestats in the HVAC or HRV ductwork.

Because an HRV is designed to bring fresh air into the building, structures may require supply voltage interrupt when smoke or flame sensors are triggered, or when a central fire alarm system is activated.

Supply air grilles may be ceiling or high wall mounted. Avoid locating incoming fresh air grilles that could cause a direct draft on the occupants as the incoming air may be below room temperature. A reheat duct heater can be installed to improve occupant comfort.

Adjustable Grilles

The use of balancing dampers or adjustable grilles as supply air diffusers and air exhaust covers are recommended. TECHGRILLES™ are round, efficient, sound absorbing devices available in 4", 5", 6" and 8" (100, 125, 150, and 200 mm) models.

Part# 99-EAG4 4" diameter Techgrille

Part# 99-EAG5 5" diameter Techgrille

Part# 99-EAG6 6" diameter Techgrille

Part# 99-EAG8 8" diameter Techgrille

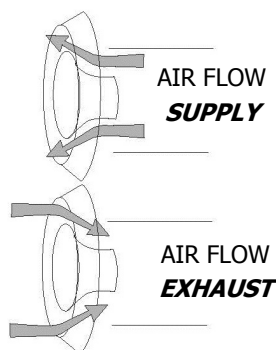

The Integrated HVAC System

The HRV has become an integral component of the HVAC system. Figure A shows an HRV unit providing fresh air directly to the return air plenum of a rooftop heat/cool unit.

In the balanced airflow system, the HRV exhaust removes stale room air (eg. from lunch room, storage or copy area) and returns to the space an equal amount of fresh outdoor air, making the use of an economizer obsolete in conjunction with an HRV.

Many buildings have ceiling return air plenum as in Figure B. Fresh air from the HRV can be introduced directly into the ceiling space but this should occur near the air handler's intake.

By operating the HRV on a 24 hour / 7 day battery backed timer, the unit can be set to operate only when occupancy or indoor conditions require the air exchange.

In installations where it is satisfactory to provide general exhaust from the space, the air to be exhausted may be taken directly from the return air plenum to the HRV as it is drawn back to the air handler. Fresh air supplied by the HRV is then introduced directly into the return air plenum but at a location closer to the air handler. The air handler would have a constant running blower to effectively distribute the fresh air and remove the stale air. Balancing dampers would be located in both the HRV supply and exhaust ducts between the return air plenum and the HRV.

NOTE: At no time should the air handler T.E.S.P. on the return duct exceed that of the HRV .



CAUTION

When interlocking a rooftop unit with an HRV, take care to ensure the fans of both units operate in the correct rotation.

Figure A

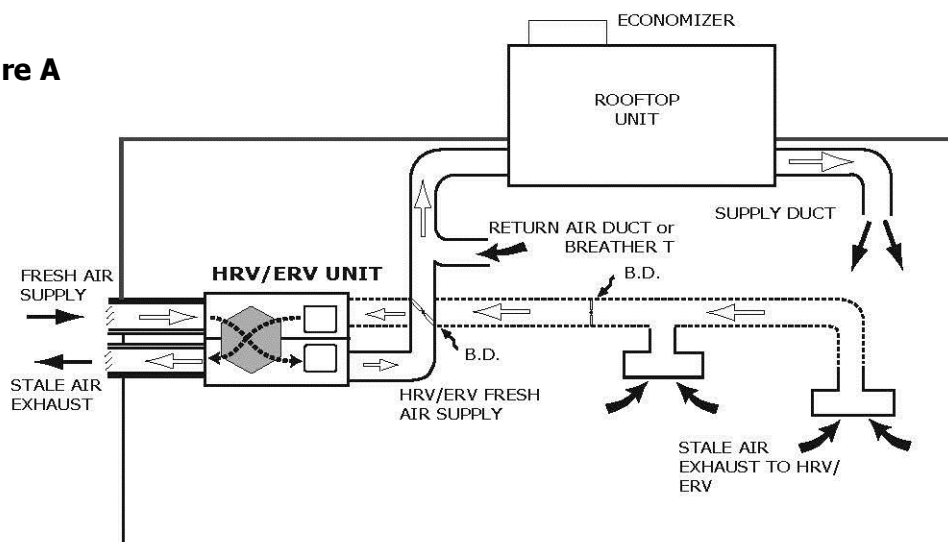
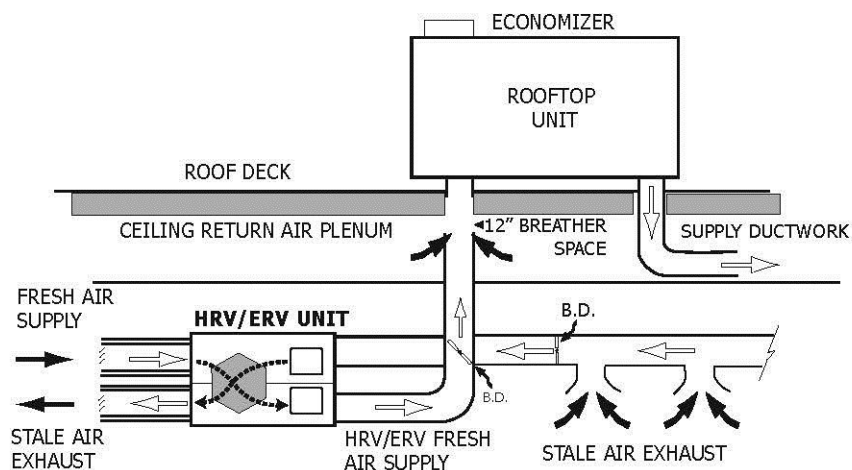

Figure B



Drain Connections

The HRV must be level for proper drainage of condensate from the drain pans.

Install a loop or "P Trap" in the condensate line and pour a cup of water into the drain pan. This will create a water seal which will prevent odors from being drawn up the hose and into the fresh air supply of the HRV.

Install the drain pans in the bottom of the HRV so the drain connections protrude through the holes provided. Use drain hoses with hose clamps to connect the drain pan outlets to a floor drain or standpipe. Make sure the drain line slopes down to the outlet. If this is not possible, a condensate pump will be required for positive removal of the water. Protect the drain line from freezing.

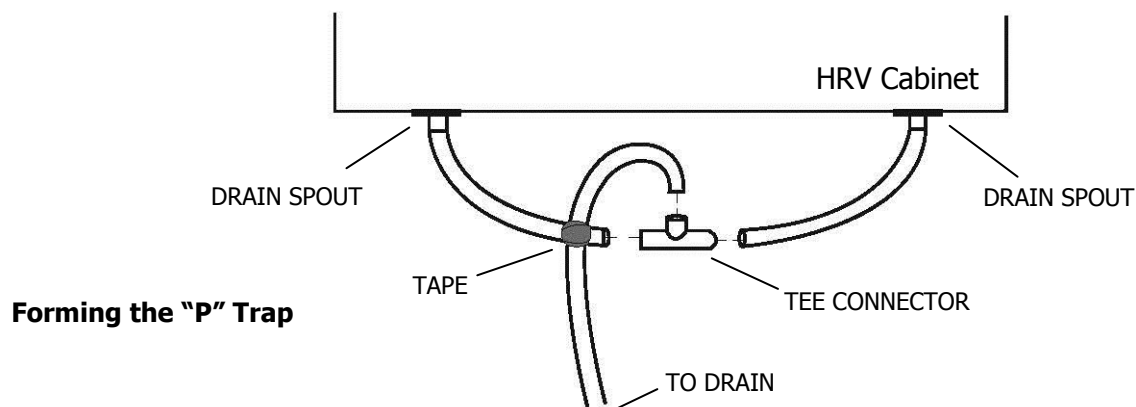

Forming the "P" Trap

! CAUTION

The HRV and all condensate lines must be installed in a space where the temperature is maintained above the freezing point.

! CAUTION

Drain trap and tubing **MUST** be below bottom of door with 1/4" per foot downwards slope away from unit.

Electrical Connections

Electrical Connections

It is recommended that a licensed electrician make all electrical connections. It is very important that the unit be properly grounded. The circuit must be sized to handle the F.L.A. indicated on the name tag for the circuit.

WARNING: Verify the polarity of the power coming into the unit with a test lamp or multimeter. Connect the multimeter or test lamp probe to the wire being tested and the other probe to ground. The black line should be "live". If the white line is "live" the polarity is reversed and must be corrected. If both lines are live, the voltage is not 120VAC. The black open line from the unit should be connected to the live line and the white open line should be connected to the neutral line. Some unit have a safety disconnect rocker switch located just outside of the electrical control box area. The switch disconnects the live line. Verify that it is working properly with a multimeter or test lamp. Always ensure the HRV is properly grounded before and after testing.

! CAUTION

The HRV is designed to operate with ducting. When first starting the HRV, measure the amp draw to each motor at each speed to ensure it is operating at or below the max rating.

	Maximum AMP Rating		
	HIGH	MED.	LOW
1200DD, 1200FD	9.4	6.0	4.5
700DD, 700FD	4.5	3.2	2.4
650DD, 650FD	4.6	3.0	2.3
455DD, 455FD	2.0	1.4	1.0

HRV Defrost Strategies (Fan Defrost and Damper Defrost)

Fan Defrost

Models 455FD, 700 FD, 650FD, 1200FD

Fan defrost HRV's are equipped with an electronically controlled fan defrost system to remove frost that collects on the warm air side of the aluminum heat transfer surfaces of the heat exchanger core. When the outside air temperature drops below 27°F (-3°C), defrost is activated which provides for an automatic defrost cycle. During the automatic defrost cycle the fresh air supply is shut off while the exhaust fan continues to operate. This allows warm inside air to flow through the heat exchanger core melting frost accumulation. After the defrost period, the fresh air supply fan automatically returns to the normal speed and fresh outside air continues to be drawn into the building. Water from the melted frost collects in the bottom drip pans and drains out through the bottom drain connections. The defrost cycle repeats automatically until the air temperature rises above 27°F (-3°C).

Damper Defrost

Models 455DD, 700DD, 650DD, 1200DD

These damper defrost HRV's have an electronically controlled damper defrost mechanism. If the outside temperature drops below 27°F (-3°C), the defrost timer is activated. A motor driven damper door mechanism opens the defrost port and at the same time closes off the supply air from outside. After the defrost period, the damper operates in the opposite direction to close off the defrost port and reopen the fresh air at the supply port. Defrost cycle repeats until the temperature again rises above 27°F (-3°C).

Defrost Time Adjustment

455FD/DD, 700FD/DD, 650FD/DD, 1200FD/DD

DIP switch #8 will adjust the defrost time. Do not change any of the other DIP switch settings.

! ATTENTION

Change DIP switch #8 only as illustrated on this page. Do not adjust any other switches.

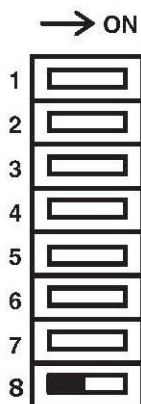

Factory Setting (DIP Switch 8 OFF)

The HRV enters defrost mode when outdoor temperatures drop below 27°F (-3°C).

The factory defrost cycle is 4 minutes defrost with a 30 minute run time.

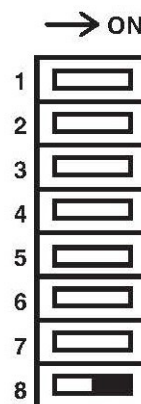

Increased Defrost Time (DIP Switch 8 ON)

Cooler climates may require a more aggressive defrost cycle.

Positioning DIP switch 8 to ON will initiate a 4 minute defrost with a 20 minute run time.

Reversing the Supply and Defrost Air Ports (Damper Defrost Units only- Models 455DD, 650DD, 700DD, 1200DD)

Sometimes installation is easier if the "Supply Air from Outside" is ducted from the upper left side port (Defrost Air) instead of the top port.

Changing the functionality of these two ports is easily accomplished by switching the red and yellow defrost motor wires at the circuit board. Switch T37 and T39 on the Aircom circuit board.

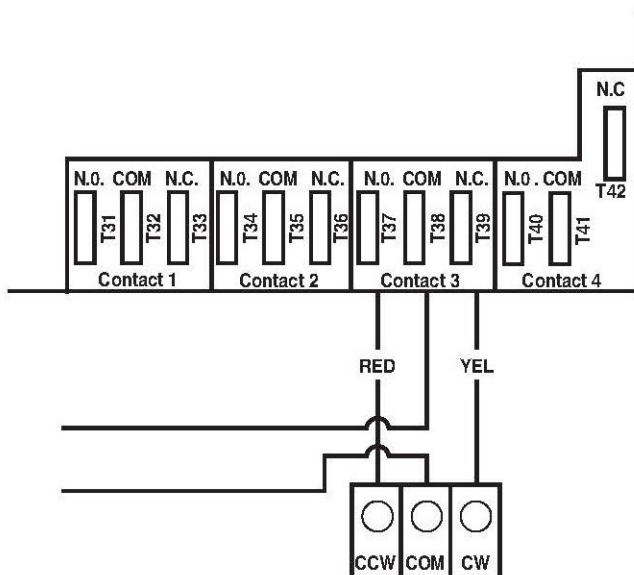
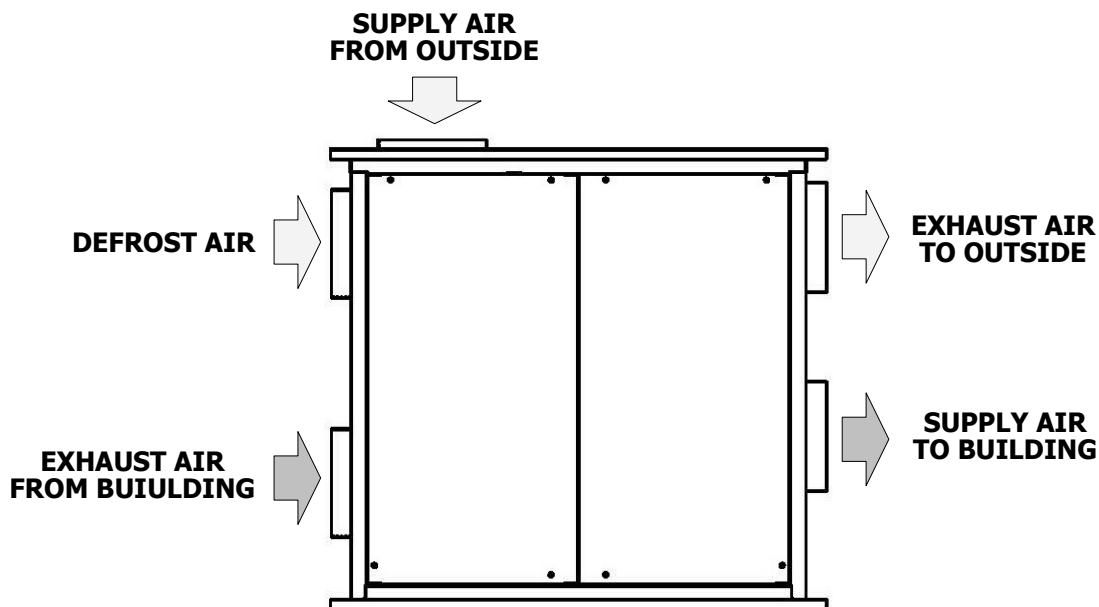

Switch T37 (red wire) and T39 (yellow wire) on the Aircom circuit board if you wish to reverse the "Supply Air From Outside" and "Pool and Defrost Air" ports.

This illustration shows the factory configuration.

Optional Lifebreath Ventilation Control - Part #99-BC02

Key Features:

- 2 speed fan setting (LOW / HIGH)
- Standby setting (fan OFF)
- Electronic Dehumidistat
- Compatible with 99-DET02 Wireless Timers
- Slim-line design
- Connect to 3 wire 20 gauge low voltage wire

BC02 Operating Instructions:

Turning on the Control

Press and release the ON/OFF button . The light above will illuminate.

Setting the Ventilation Speed

Press and release the Fan button  to select LOW or HIGH fan speed. The corresponding "Indicator Light" will illuminate. If both LO and HI indicator lights are off, the fan is OFF but will turn ON if required by the Dehumidistat or remote Timer (if installed).

Humidity Control

Your unit will reduce indoor humidity when outdoor humidity levels are lower than indoor humidity levels. This feature is only effective when the outdoor temperature is below 59°F (15°C).

Setting the Dehumidistat

Press and release the Dehumidistat button  until the Dehumidistat Light is at the desired setting. After a few seconds the Dehumidistat light will either flash or be on continuous.

A flashing light indicates the humidity level is higher than the setting and the unit is operating on high speed ventilation. A continuous light indicates the humidity level is lower than the setting. Refer to the unit's Home Owner's manual for instructions on how the Dehumidistat works.

The Dehumidistat will override the current speed setting to HIGH speed.

The Dehumidistat function can be turned OFF by pressing the  button until no Dehumidistat light is on.

Note - Only 1 Dehumidistat should be installed in a system.

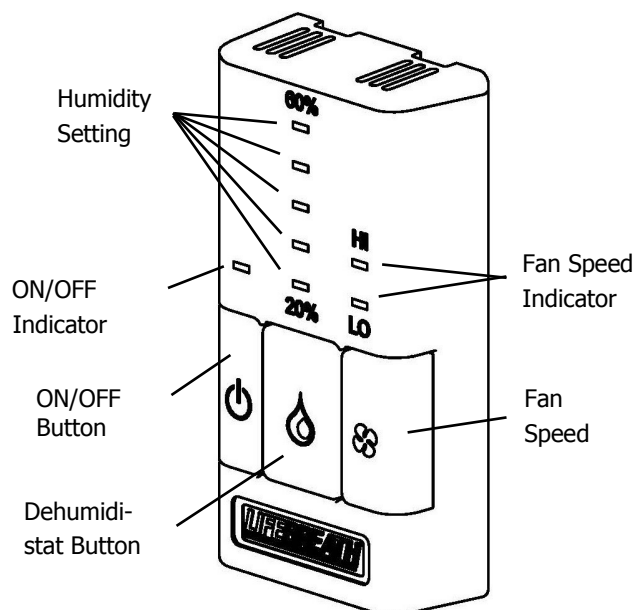

Optional Lifebreath 3 Speed Control - Part #99-500

Key Features:

- 3 Speed Fan setting (LOW / MEDIUM / HIGH)
- 4 wire; 20 gauge wire (minimum)
- Connect to Red, White, Yellow, Green.

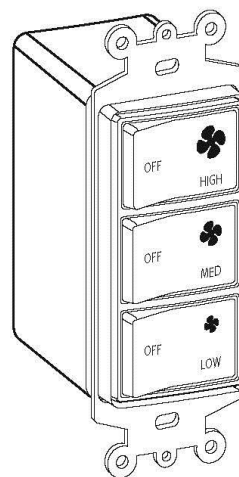

! ATTENTION

When used in conjunction with the 99-BC02, the BC02 control must be ON for the 99-500 control to operate. The 99-BC02 will override the 99-500 control when the Dehumidistat is operating or the control is set to HIGH speed.

Optional Lifebreath Dehumidistat - Part #99-DH01

Key Features:

- The Dehumidistat measures the indoor humidity level and will initiate high speed ventilation when the moisture level in the building exceeds the set point on the control.
- Once the humidity in the building is reduced, the HRV will revert back to its previous setting.
- The Dehumidistat should be set to OFF for all season except the heating season.
- Connect to 3 wire 20 gauge low voltage wire.

Humidity Control

Your HRV will produce a dehumidifying effect when outdoor humidity levels are lower than indoor humidity levels. Never use the Dehumidistat feature when outdoor temperatures are above 59 F (15 C).

Note: The indoor humidity level is measured at the control.

Setting the Dehumidistat

Press and release the Dehumidistat button until the Dehumidistat Light is at the desired setting. After 5 seconds the Dehumidistat light will either flash or be on continuous.

A flashing light indicates the humidity level is higher than the setting and the unit is operating on high speed ventilation. A continuous light indicates the humidity level is lower than the setting. Refer to the unit's Operation & Installation Manual for instructions on how the Dehumidistat works.

Note - Only 1 Dehumidistat should be active on a system.

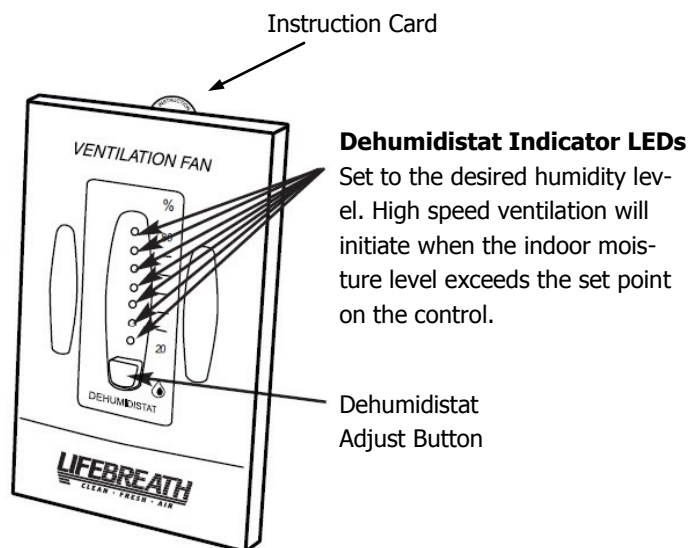





Dehumidistat Indicator LEDs

Set to the desired humidity level. High speed ventilation will initiate when the indoor moisture level exceeds the set point on the control.

Optional Lifebreath Wireless Timer - Part #99-DET02

The Timers may be installed onto a flush mounted electrical switch box or it may be surface mounted onto a wall. Multiple Timers may be installed in a ventilation system. To increase the range of a wireless Timer, a RX02 Repeater should be used.

Pairing:

1. Turn on the main wall control by pressing the ON/OFF button  and remove the battery from Timer.
2. Press the left and right buttons simultaneously on the main wall control ( and ). The bottom row of 3 LED's will begin flashing. This indicates that the main control is now in pairing mode. (Figure E)
3. Keep the Timer within 16" of the main wall control when pairing.
4. Install the battery in the DET02 Timer. All four lights on the Timer will immediately flash 5 times, then only the red battery light will remain on for approximately 12 seconds after which the "40" light flashes the rev code. 20, 40, 60 lights will flash until paired or will stop if not paired within 12 seconds. If pairing was not successful you now must return to step 1 to restart the pairing process.
5. Press the  button on the main wall control to exit.

To pair additional DET02 Timers with the same wall control, or if pairing was not successful, repeat steps 1-6.

When paired, the DET02 Timers can be moved and installed elsewhere. Estimated range of the Timer is 40' with no obstructions. A RX02 Repeater may be installed to increase the range of the Timers.

Test if pairing was successful by pressing the Select Button and listen for the HRV / ERV to initiate HIGH fan speed Ventilation.

Un-pairing:

1. Remove the battery from the back of the DET02 Timer.
2. Press and hold the Select Button on the front of the Timer.
3. While holding the Select Button, reinsert the battery in the Timer. Continue holding the select button until the LED under "40" begins flashing. The DET02 Timer will now be unpaired with the main wall control.



Note

The wireless Timers and Repeaters must be matched to the main wall control of the HRV / ERV. This process is called "Pairing". Multiple Timers and Repeaters can be paired to a single wall control.

Figure A

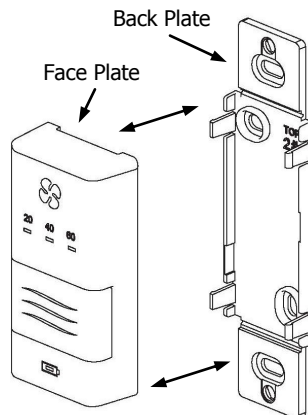

Figure B

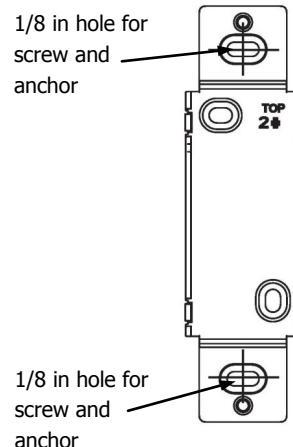

Figure C

Alternate Wall Mount

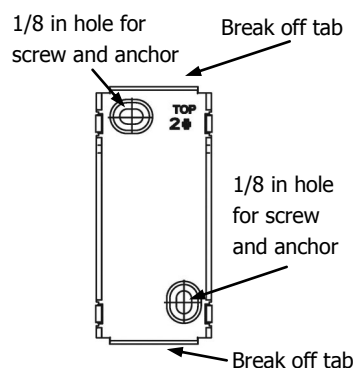

Figure D

BC02 Control

NOTE: Your control may look different than the one shown.

Press simultaneously to initiate pairing mode

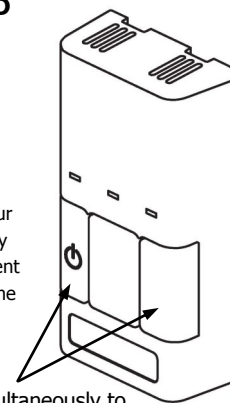
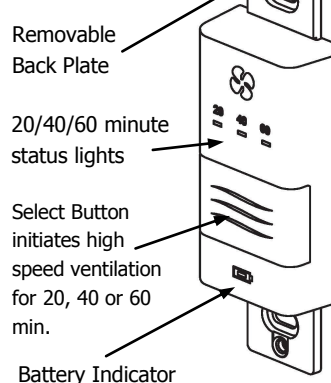

Figure E

DET02 Timer



Optional Lifebreath Wireless Timer - Part #99-DET02

Installation of Wireless Timer

1. Separate the Face Plate from the Back Plate by firmly pulling apart (Figure A).
2. For mounting the control without a Decora plate, break off top and bottom tabs and refer to Figure C for mounting.
3. Place the Back Plate of the control in the desired location on the wall and pencil mark the top and bottom screw holes (Figure B or C). Drill two 1/8" holes.
4. Attach the Back Plate to the wall using the 2 supplied screws and anchors.
5. Attach the Face Plate to the Back Plate (Figure A).

Overview of Lifebreath Wireless 20/40/60 Minute Timer

Initiates HIGH speed Ventilation for 20, 40 or 60 minutes. The 20/40/60 minute Status Lights indicate HIGH speed operation.

Wireless Timers have an estimated range of 40' with no obstructions. To increase the range of a Wireless Timer a 99-RX02 Repeater may be used.

Using the Wireless Timer

When paired to the main wall control, the Wireless Timer may be moved to a remote location in the home such as a bathroom.

Pressing the Select Button on the Timer will initiate HIGH speed fan operation. The corresponding Status Light will illuminate under the number on the Timer to indicate either 20, 40 or 60 minutes of HIGH speed fan operation. To cancel the call for HIGH speed fan operation, press the Select Button until the Status Lights are no longer illuminated.

Replacing the Battery

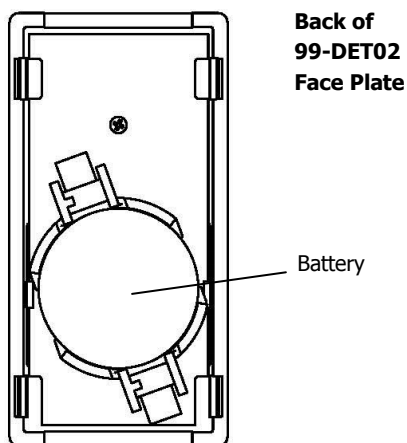
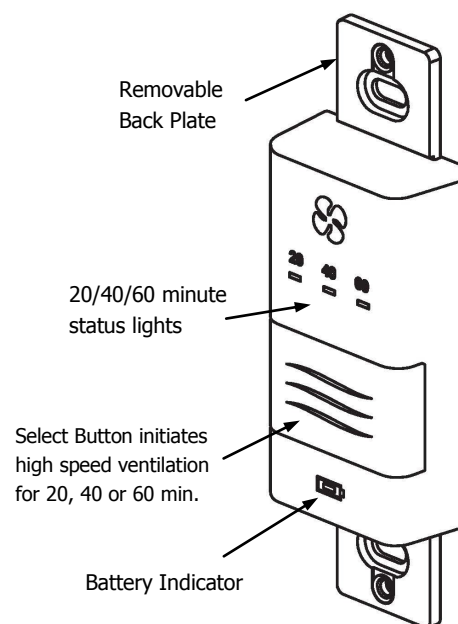
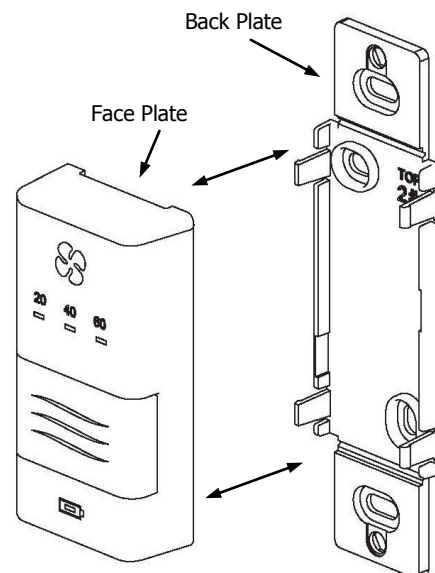

When the battery needs to be replaced in the Wireless Timer, the red LED Battery Indicator will illuminate.

To replace the battery, first remove the Face Plate by pulling it off the wall. On the back of the Timer Face Plate the battery will be exposed. Replace the battery and re-attach the Face Plate to the Back Plate. Be careful not to damage the tabs on the Back Plate when re-attaching the Face Plate.



Optional Lifebreath Wireless Repeater - Part #99-RX02

The RX02 Repeaters are to be plugged directly into a 120V power outlet

1. Turn on the main wall control by pressing the ON/OFF button .
2. Press the left and right buttons simultaneously on the main wall control ( and ). The bottom row of 3 LED's will begin flashing. This indicates that the main control is now in pairing mode.
3. The RX02 Repeater must be powered within 16" of the main wall control for pairing. If an outlet is not available an extension cord should be used to power the repeater initially for pairing.
4. Plug the RX02 Repeater into the power outlet. The green light will flash after approximately 12 seconds indicating that the repeater is paired with the main wall control.
5. Press the ON/OFF button on the main wall control to exit pairing mode and the Repeater may now be unplugged and moved to its permanent location.

To pair additional RX02 Repeaters with the same wall control, repeat steps 1-5 until all Repeaters have been paired.

When installed in its permanent location, the green LED will remain solid to indicate the best location and the Repeater can be moved farther if required. The green LED will flash to indicate it is in a good location. A red light indicates the Repeater is out of range and needs to be moved closer to the main wall control.

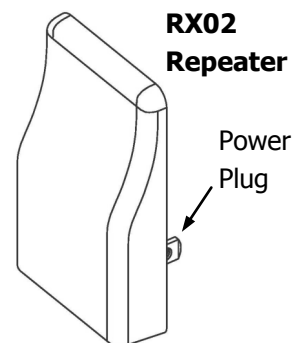

Optional Lifebreath 20/40/60 Minute Timer - Part #99-DET01

Operating the Timer

Press and release the Select Button to activate a 20, 40 or 60 minute HIGH speed override cycle. The Light will illuminate and the unit will run on HIGH speed Ventilation for the selected time. The Light will dim after 10 sec. for run time. The Light will flash during the last 5 min. of the cycle. The Timer connected to the unit will illuminate for the duration of the override when the Select Button is pressed.

Lockout Mode

Lockout Mode is useful if you wish to disable the Timers. The Timer can be set to lockout mode by pressing and holding the Select Button for five seconds. After 5 sec., the Light will flash; release the Select Button. The Timer is now in lockout mode. If the Select Button is pressed during lockout mode the Light will momentarily illuminate but no override will be initiated.

If lockout mode is initiated when the Timer is activated, the Timer will continue its timed sequence but will not allow any further overrides to be initiated. Lockout mode can be unlocked by pressing and holding the Select Button for 5 sec. After 5 sec. the Light will stop flashing. Release the Select Button and the Timer will now operate normally.

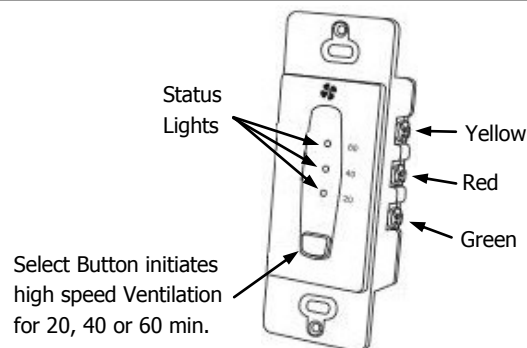

NOTE

- Timers mount in standard 2" x 4" electrical boxes.
- Wire multiple timers individually back to the unit.
- Use 3/20 low voltage wire

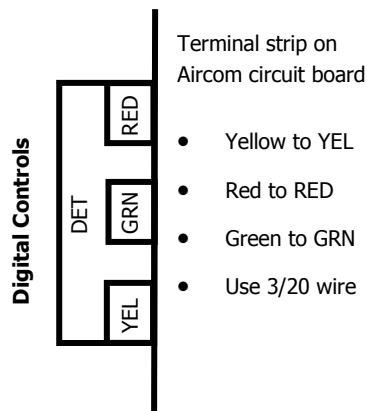

Function and Controls

Basic Functions

Speed control is obtained by powering 24V to one of the designated speed taps.

Example:

A jumper between the **R** terminal and the **G** terminal will result in low speed operation.

Setup

Select appropriate operational speed by installing the jumper wire between one of the designated speed taps. (A jumper wire is factory installed in the low speed position.)

Note:

It is recommended to use the optional speed control Part # 99-500 in order to obtain 3 speed fan control.

Jumper wire placement on microprocessor board

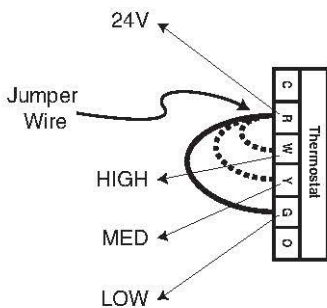

SPEED	JUMPER	
High	R	W
Medium	R	Y
Low	R	G

Optional 3 Speed Control (Part #99-500)

Connect to R, W, Y and G on Thermostat

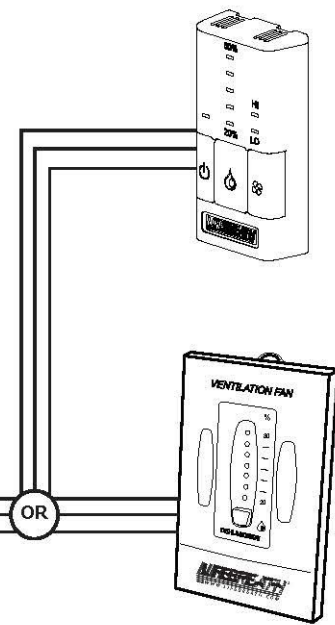
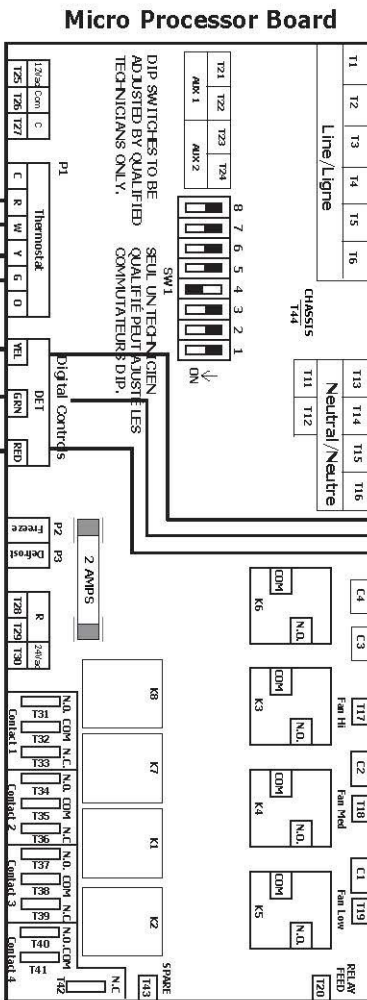
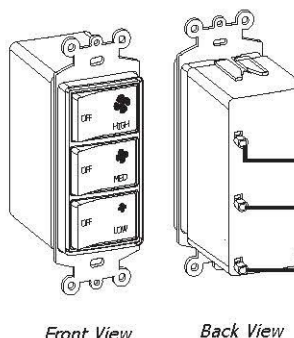

Optional 20/40/60 Minute Timer Part# 99-DET01

- Boost unit to Ventilation Mode for 20, 40, 60 minutes (no speed change).
- Connect up to 4 maximum
- Connect to Yellow, Red & Green

Refer to "Connecting Optional Control" in this manual for instructions on connecting the optional Life-breath Ventilation Control (Part# 99-BC02) and optional Life-breath Dehumidistat (Part# 99-DH-01) Connect to Yellow, Red & Green

Connecting Optional Control - Part #99-BC02

The control is to be surface mounted onto a wall.

Only 1 master control should be installed to a ventilation system (the Face Plate on this illustration may not be exactly the same as yours).

1. Separate the Face Plate from the Back Plate by firmly pulling apart (Figure A). Be careful not to damage Face Plate Contact Pins.
2. For mounting the control without a Decora plate, break off top and bottom tabs and refer to Figure C for mounting.
3. Place the Back Plate of the control in the desired location on the wall and pencil mark the top and bottom screw holes (Figure B or C).
4. Remove the Back Plate and mark the center hole for the wires in the middle of the screw holes. Refer to Figure B or C for placement.
5. Cut in a 3/4 in by 1 in oval hole in the wall to allow for the wire opening and drill (two) 1/8 in holes for the screws and wall anchors (Figure B or C).
6. Pull 3 wire 20 gauge (min.) 100 ft length (max.), through the opening in the wall.
7. Connect red, green, and yellow to the Wiring Terminals located on the Back Plate (Figure B or C).
8. Attach the Back Plate to the wall using the 2 supplied screws and anchors.
9. Attach the Face Plate to the Back Plate (Figure A). Note: Be careful to correctly align the Face Plate to avoid damaging the Face Plate Contact Pins.
10. Connect the 3 wire 20 gauge (min.) 100 ft length (max.) to the digital controls terminal strip located on the Aircom circuit board (Figure D).

! ATTENTION

Pay special attention not to damage the Contact Pins when attaching and detaching the Face Plate. (Figure B)

Figure A

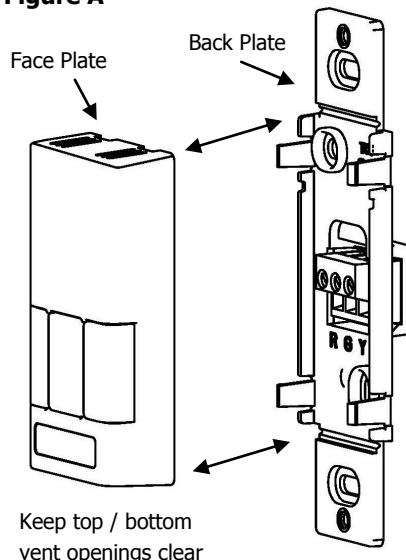

Figure B

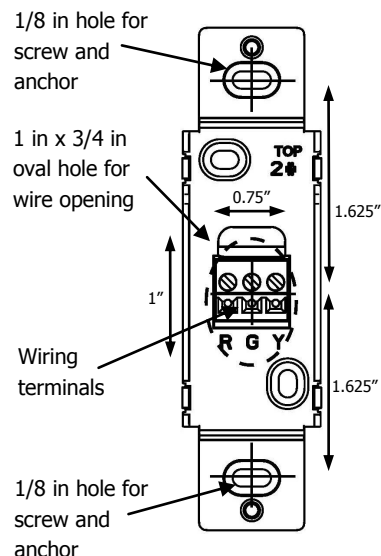

Figure C

Alternate Wall Mount

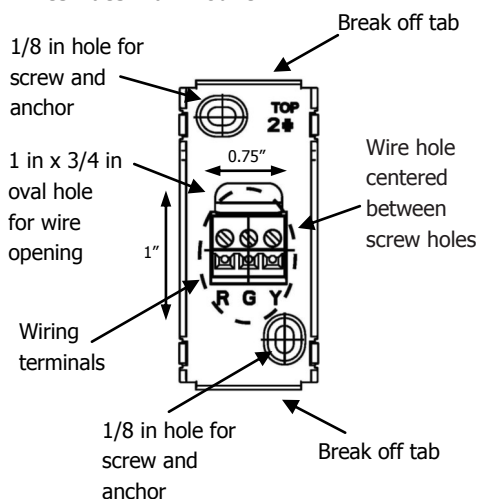
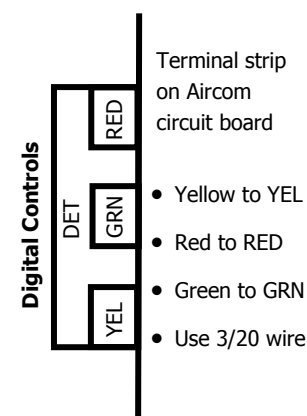

Figure D



Connecting Optional Control - Part #99-DH01

The Lifebreath Dehumidistat may be installed onto a flush mounted 2" x 4" electrical switch box or it may be surface mounted onto a wall.

Only 1 master control should be installed to a ventilation system (the Face Plate on this illustration may not be exactly the same as yours).

1. Remove the Operating Instructions Card from the top of the Control (Figure A).
2. Separate the Face Plate from the Back Plate by firmly pulling apart (Figure B). Be careful not to damage Face Plate Contact Pins.
3. Place the Back Plate of the control in the desired location on the wall and pencil mark the wall in the center of the Wire Opening, Top Screw Hole and Bottom Screw Hole (Figure C).
4. Remove the Back Plate and drill a 3/8" opening in the wall to allow for the Wire Opening and a 1/8" hole for the Wall Anchors for the top and bottom screw holes (Figure D).
5. Pull 3/20 wire through the opening in the wall and the Wire Opening of the Back Plate (Figure C).
6. Connect Red, Green and Yellow to the Wiring Terminals located on the Back Plate (Figure C).
7. Secure a single wire to the Wire Retainer located on the Back Plate (Figure C).
8. Attach the Back Plate to the wall using the 2 supplied screws and anchors.
9. Attach the Face Plate to the Back Plate (Figure B). Note: Be careful to correctly align the Face Plate to avoid damaging the Face Plate Contact Pins.
10. Insert the Operating Instructions Card into the control (Figure A).
11. Connect the 3 wire 20 gauge (min.) 100 ft length (max.) to the digital controls terminal strip located on the Aircom circuit board (Figure E).

! ATTENTION

Pay special attention not to damage the Contact Pins when attaching and detaching the Face Plate. (Figure B)

Figure A - Face Plate

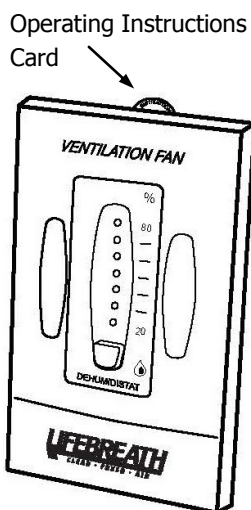

Figure C

Front View of Back Plate

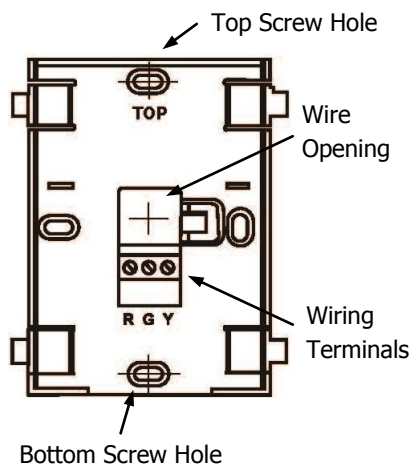

Figure E

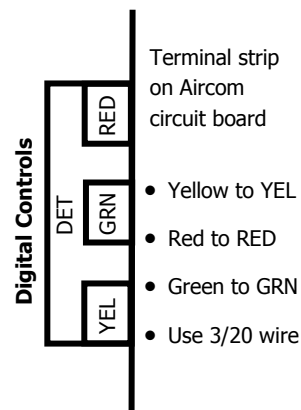

Figure B

Side View

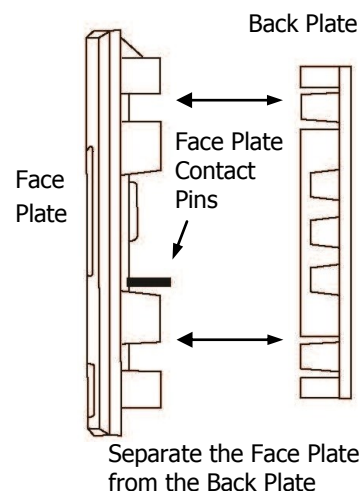

Figure D

Drill Holes in Wall

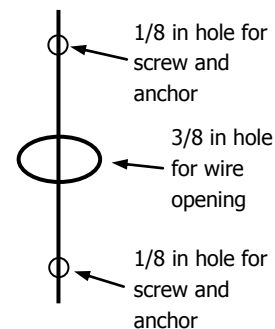
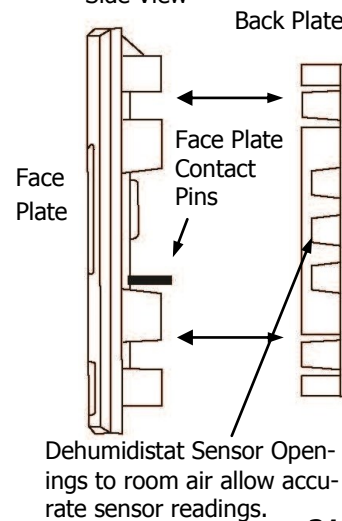

Figure F

Side View



Pitot Tube Air Flow Balancing - Commercial

It is necessary to have balanced air flows in an HRV. The volume of air brought in from the outside must equal the volume of air exhausted by the unit. If the air flows are not properly balanced, then;

- The HRV may not operate at its maximum efficiency
- A negative or positive air pressure may occur in the building
- The unit may not defrost properly
- Failure to balance HRV properly may void warranty

Excessive positive pressure may drive moist indoor air into the external walls of the building where it may condense (in cold weather) and degrade structural components. May also cause key holes to freeze up.

Excessive negative pressure may have several undesirable effects. In some geographic locations, soil gases such as methane and radon gas may be drawn into the home through basement/ground contact areas. Excessive negative pressure may also cause the back-drafting of vented combustion equipment.

Read the Application Warning on the front of this manual!

Prior to balancing, ensure that:

1. All sealing of the ductwork system has been completed.
2. All of the HRV's components are in place and functioning properly.
3. Balancing dampers are fully open.
4. Unit is on HIGH speed.
5. Air flows in branch lines to specific areas of the house should be adjusted first prior to balancing the unit. A smoke pencil used at the grilles is a good indicator of each branch line's relative air flow.
6. After taking readings of both the stale air to the HRV duct and fresh air to the house duct, the duct with the lower CFM ([L/s] velocity) reading should be left alone, while the duct with the higher reading should be adjusted back to match the lower reading. See **Adjusting the Airflow**.
7. Return unit to appropriate fan speed for normal operation

BALANCING PROCEDURE

The following is a method of field balancing an HRV using a Pitot tube, advantageous in situations when flow stations are not installed in the ductwork. Procedure should be performed with the HRV on high speed.

The first step is to operate **all** mechanical systems on **high speed**, which have an influence on the ventilation system, i.e. the HRV itself and the forced air furnace or air handler if applicable. This will provide the maximum pressure that the HRV will need to overcome, and allow for a more accurate balance of the unit.

Drill a small hole in the duct (about 3/16"), three feet downstream of any elbows or bends, and one foot upstream of any elbows or bends. These are recommended distances but the actual installation may limit the amount of straight duct.

The Pitot tube should be connected to a manometer capable of reading 3 digits of resolution. The tube coming out of the top of the pitot is connected to the high pressure side of the gauge. The tube coming out of the side of the pitot is connected to the low pressure or reference side of the gauge.

Insert the Pitot tube into the duct; pointing the tip into the airflow.

For general balancing it is sufficient to move the pitot tube around in the duct and take an average or typical reading. Repeat this procedure in the other (supply or return) duct. Determine which duct has the highest airflow (highest reading on the manometer). Adjust the higher airflow by reducing the fan speed (see "Adjusting the Airflow"). The flows should now be balanced. Actual airflow can be determined from the gauge reading. The value read on the gauge is called the velocity pressure. The Pitot tube comes with a chart that will give the air flow velocity based on the velocity pressure indicated by the gauge. This velocity will be in either feet per minute or meters per second. To determine the actual airflow, the velocity is multiplied by the cross sectional area of the duct being measured.

This is an example for determining the airflow in a 6" duct. The Pitot tube reading was 0.025 inches of water.

From the chart, this is 640 feet per minute.

The 6" duct has a cross sectional area of

$$= [3.14 \times (6" \div 12) \div 2]^2 \div 4 \\ = 0.2 \text{ square feet}$$

The airflow is then:

$$640 \text{ ft./min.} \times 0.2 \text{ square feet} = 128 \text{ cfm}$$

For your convenience, the cross sectional area of some common round duct is listed below:

DUCT DIAM. (inches)	CROSS SECTION AREA (sq. ft.)
5 (127 mm)	0.14
6 (152 mm)	0.20
7 (178 mm)	0.27

The accuracy of the air flow reading will be affected by how close to any elbows or bends the readings are taken. Accuracy can be increased by taking an average of multiple readings as outlined in the literature supplied with the Pitot tube.

Pitot tube and gauge

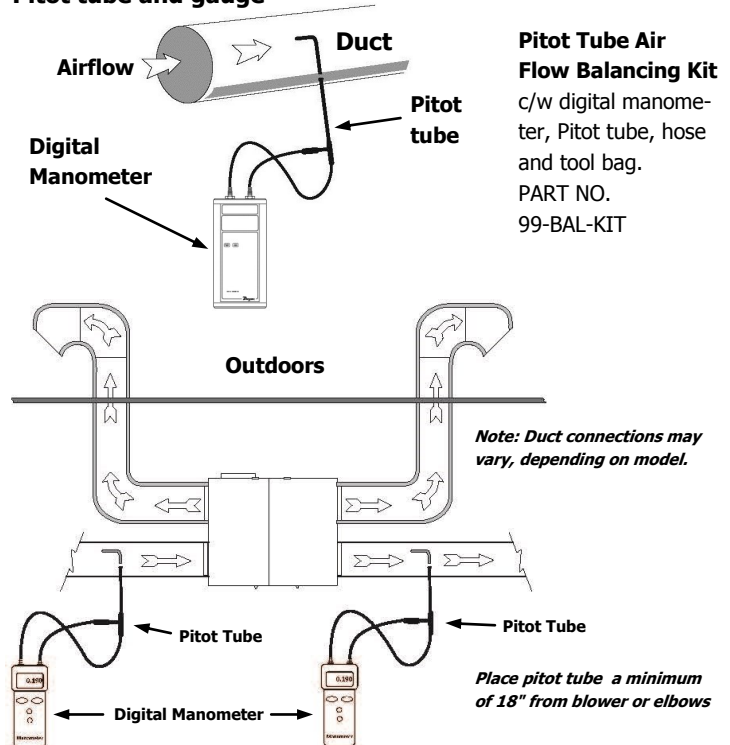

Service and Maintenance

Servicing your HRV on a regular schedule will result in optimum operating efficiencies and prolonged life of the equipment.

Due to numerous applications in which this equipment can be installed, it is difficult to predict servicing intervals. In certain situations where there is heavy smoke, servicing the equipment every one - two months may be needed; whereas ventilating a meeting room for carbon dioxide may only need service every six months to a year.

Motor

Access to the motor is through the front service doors. Note heat exchanger core can be removed to provide more room. See **HRV Core** in this section.

The motor is a permanent split capacitor type (PSC) which uses a sleeve mechanism to steady the shaft.

HRV Core

The heat exchange core is accessible through the front service door. Special care and attention should be given to this component as the edges may be sharp, and the core itself susceptible to damage if dropped.

When removing the core, the location it is removed from should be noted.

The core is removed by carefully pulling the core outward from the unit, sliding it evenly along its guide rail supports found on the top and bottom corners, and on either side of the core. Note the core may have some resistance when sliding out. Avoid tilting the core as this will result in its edges catching the guide rail and temporarily preventing its removal.

In most cases, washing the core in a mild detergent and warm water will be all that is needed to completely clean them. Do not use harsh chemicals as this may cause corrosion in the HRV. The time between core service will depend on the application the HRV has been installed in. It can be as often as one - two months or at the very least, cleaned every six months. When reinstalling the core you must note foam location and drip edge location for proper core placement. See diagram below.

Models 455, 700, 1200

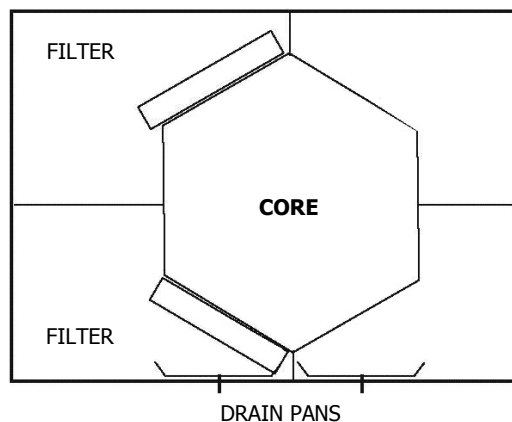

Model 650

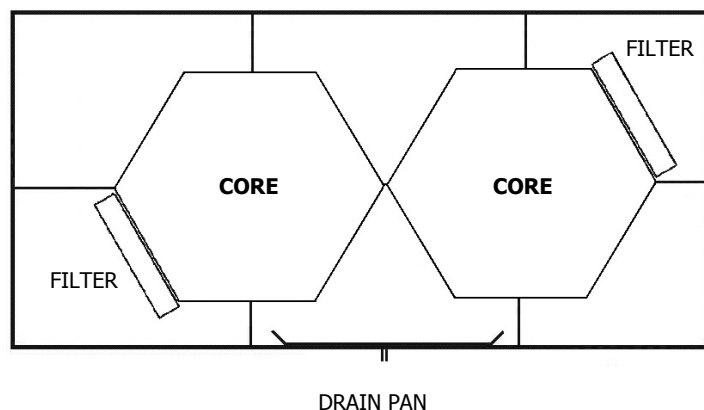

When removing cores and filters note their location and arrangement.

Service and Maintenance

Filters

Open front service door to access the filters located in both supply and exhaust air streams. Note to remove and install filters, it may be easier to first remove the core(s). Refer to **HRV Core**.

The filters are designed to stop large particles from entering in the core. The filters are fastened in place by a metal spring rod. To remove filters from core(s) simply pull the rod from one end, outward until free from core lip, and remove.

Only use warm water with a mild detergent to wash the filters. Do not use harsh chemicals.

The time between filter service will depend on the application the HRV has been installed in. It can be as often as one - two months or at the very least, cleaned every six months.

Condensate Drains

The condensate drains consist of two drain pans which may collect water after the HRV initiates a defrost cycle, and a drain line to remove the condensate.

Maintenance on this portion of the system should be done as often as possible and should not exceed six months. Note bacterial growth in standing water is a major concern to healthy indoor air quality, and should be avoided whenever possible.

To clean these components, open the front service door and flush the pans with water. Ensure that the pans drain completely and in a reasonable amount of time. Note if the water does not drain right away, check for blockage in the drain line, also check that the drain line has a good slope to it. (1/8 - 1/4" per foot)

The drain line itself should have a "P" trap in it below the HRV which is to be filled with water to prevent odors or gases from entering back into the unit.

Duct Work

It is a good idea to inspect ducting, outside weather hoods (wall caps), and grilles for blockage and dirt buildup, at least every six months.

Outside weatherhoods should be protected by a bird screen which can plug up with debris. Also, it is a good idea to visually confirm that the fresh air supply is free from any sources of contamination, such as other vented combustion equipment added after the fact.

Damper Motor

The damper motor, (if applicable) is a self contained motor and does not require service. The damper door attached to the motor could use a little lithium grease on the shaft opposite the motor, where it enters its holder, once every two - three years.

General Maintenance

As a final step in a routine maintenance schedule, it is a good idea to confirm operation of the system, checking speed control functions and remote control operation, if applicable.

Wipe the inside of the cabinet to remove dust and cob webs as needed.

It is a good idea to keep a service/maintenance log of the unit.

Reverse Installation of the HRV

Electrical Box Removal:

1. Remove the door panels from the HRV by loosening the screws located on the face of the doors.
2. Remove the electrical box cover by removing the 4 screws fastening the cover in place.
3. Disconnect the motor wires coming through the bottom of the electrical box from the circuit board, capacitors and relays, and remove from the electrical box.
4. Pull motor wires for lower blower through hole in blower divider panel.
5. Disconnect damper motor wires (three) from the circuit board and remove from the electrical box.
6. Disconnect thermistor from circuit board and remove from electrical box.
7. Remove the 4 screws securing the electrical box to the cabinet of the HRV.

! ATTENTION

8. Remove the ground continuity screw from both the upper and lower blower pans securing them to the pan stops.

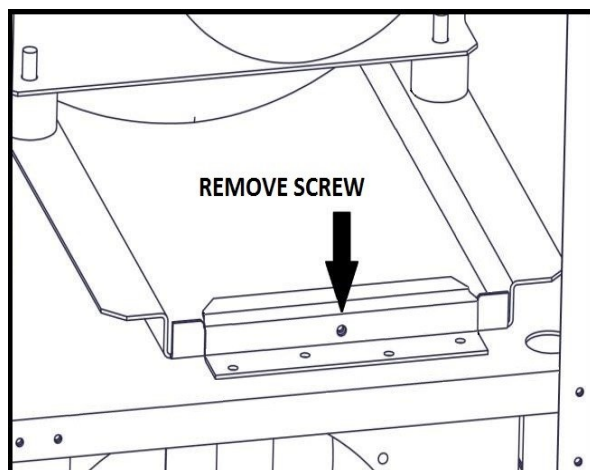

Damper Removal:

9. Cut cable tie fastening thermistor wire to bracket, disconnect thermistor from circuit, and remove thermistor.
10. On the damper motor, loosen the two set screws which hold the square damper rod in place using a 1/8" hex key.
11. Remove the machine screw and kep nut fastening the damper motor to the bracket.
12. Remove the damper motor from the bracket and ensure that the two shims are collected from either side of the damper rod, and by pulling the damper motor wires out from the top core support panel.
13. Remove the plastic snap bushing from the hole in the top core support panel where the damper wires were removed from, and install a snap plug to seal the hole, found in the manual bag.

Reinstalling the Damper Motor:

14. On the opposite side of the HRV, place the damper motor over the square damper rod aligning the end of the rod flush with the damper motor.
15. Install the machine screw and kep nut which fastens the damper motor to the bracket.
16. Insert the shim around the damper rod ensuring it is placed on the opposite side of the rod from the set screws. Both of the set screws should screw directly into the damper rod, not the shim.
17. Prior to tightening the set screws ensure proper alignment of the damper door such that it is evenly spaced over the port collars providing a good seal in both directions.
18. Once alignment is confirmed, tighten the set screws to secure the damper into place.
19. Remove the snap plug from the hole in the top core support panel, and install a plastic snap bushing in hole.
20. Route damper motor wires through hole in top core support panel.

Reverse Installation of the HRV (Continued)

Reinstalling the Electrical Box:

21. Remove the two snap plugs from the opposite side of the cabinet for electrical and control wires.
22. Install the two snap plugs in the cabinet holes on the side of the HRV which electrical box was originally removed from.
23. Route wires for both blower motors to opposite side of HRV cabinet where electrical box is to be installed.
24. Install the grounding continuity screw in both the upper and lower blower assemblies on the opposite side of the HRV where electrical box is now installed.
25. Fasten the electrical box to the cabinet of the HRV using the 4 screws that were previously removed.
26. Remove the snap plug from the blower divider panel and install plastic snap bushing provided in manual bag.
27. Install snap plug in hole in blower divider panel where lower blower motor wires were originally removed from.
28. Route the lower blower motor wires through the hole in the divider panel into the electrical box.
29. Route upper motor wires into the electrical box.
30. Route damper motor wires into e-box and connect the motor wires to the circuit board, relays and capacitors using wiring diagram found in manual for reverse installations.
31. Connect damper motor wires to circuit board using wiring diagram found in manual for reverse installations.
32. Route thermistor wire from electrical box, through hole in the top core support panel, and secure the blue end to the thermistor bracket in front of the damper motor using a plastic cable tie.
33. Connect the thermistor to the circuit board in the electrical box.
34. Putty holes closed in blower divider panel and top core support panel with wires protruding through.
35. Install the large single door panel on the now back of the cabinet where electrical box was removed from and fasten using the eight machine screws.
36. Reversing of the HRV is now complete. Continue with the installation of the HRV.

Aircom Relays

Models 455, 650, 700, 1200

The Aircom circuit board has three available "dry contact" relays. Contact 3 is not available.

Maximum 115V 10 amp resistive load.

Contact 2 and 4

These relays initiate whenever the HRV fans are operating.

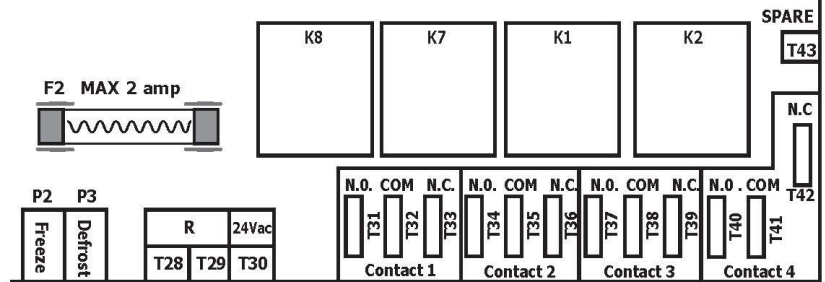

Aircom Relays

Use contact 2 or 4 to interlock the HRV to an Air Handler or Furnace.

Connecting the HRV as illustrated will ensure the Air Handler Blower Motor is operating whenever the HRV is ventilating.



CAUTION

Consideration must be given to competing air-flows when connecting the HRV in conjunction with an Air Handler/Furnace Blower system.

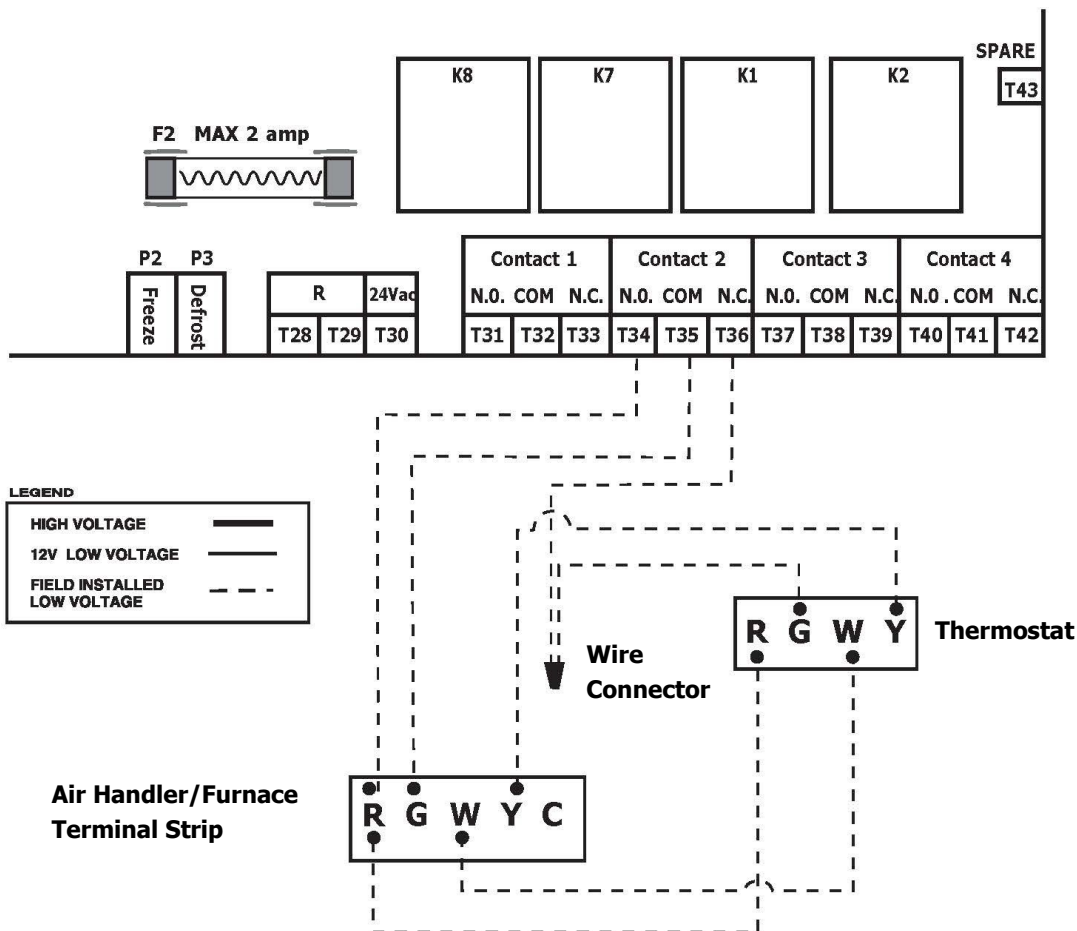

Troubleshooting Your HRV System

Symptom	Cause	Solution
Poor airflows	<ul style="list-style-type: none"> • 1/4 in (6 mm) mesh on outside hood is plugged • Filters plugged • Core obstructed • House grills closed or blocked • Dampers are closed if installed • Poor power supply at site • Ductwork is restricting HRV • Improper speed control setting • HRV airflow improperly balanced 	<ul style="list-style-type: none"> • Clean exterior hoods or vents • Remove and clean filter • Remove and clean core • Check and open grilles • Open and adjust dampers • Have electrician check supply voltage • Check duct installation • Increase the speed of the HRV • Have contractor balance HRV
Supply air feels cold	<ul style="list-style-type: none"> • Poor location of supply grilles, the airflow may irritate the occupant • Outdoor temperature extremely cold 	<ul style="list-style-type: none"> • Locate the grilles high on the walls or under the baseboards, install ceiling mounted diffuse or grilles so as not to directly spill the supply air on the occupant (i.e. over a sofa) • Turn down the HRV supply speed. A small duct heater (1 kW) could be used to temper the supply air. • Placement of furniture or closed doors is restricting the movement of air in the home • If supply air is ducted into furnace return, the furnace fan may need to run continuously to distribute ventilation air comfortably
Dehumidistat in not operating	<ul style="list-style-type: none"> • Outdoor temperature is above 15°C (59°F) • Improper low voltage connection • External low voltage is shortened out by a staple or nail • Check Dehumidistat setting it may be on OFF 	<ul style="list-style-type: none"> • Dehumidistat is functioning normally (see Auto Dehumidistat Disable in this manual) • Check that the correct terminals have been used • Check external wiring for a short • Set the Dehumidistat at the desired setting
Humidity levels are too high condensation is appearing on the windows	<ul style="list-style-type: none"> • Dehumidistat is set too high • HRV is not sized to handle a hot tub, indoor pool etc. • Lifestyle of the occupants • Moisture coming into the home from an unvented or unheated crawl space • Moisture is remaining in the wash room and kitchen areas • Condensation seems to form in the spring and fall • HRV is set at too low a speed 	<ul style="list-style-type: none"> • Set Dehumidistat lower • Cover pools, hot tubs when they are not in use • Avoid hanging clothes to dry, storing wood and venting clothes dryer inside. Firewood may have to be moved outside • Vent crawl space and place a vapor barrier on the floor of the crawl space • Ducts from the washroom should be sized to remove moist air as effectively as possible, use of a bathroom fan for short periods will remove additional moisture • On humid days, as the seasons change, some condensation may appear but the homes air quality will remain high with some HRV use • Increase speed of the HRV
Humidity levels are too low	<ul style="list-style-type: none"> • Dehumidistat control set too low • Blower speed of HRV is too high • Lifestyle of occupants • HRV airflows may be improperly balanced 	<ul style="list-style-type: none"> • Set Dehumidistat higher • Decrease HRV blower speed • Humidity may have to be added through the use of humidifiers • Have contractor balance HRV airflows
HRV and/or ducts frosting up	<ul style="list-style-type: none"> • HRV airflows are improperly balanced • Malfunction of the HRV defrost system 	<ul style="list-style-type: none"> • Note: minimal frost build-up is expected on cores before unit initiates defrost cycle functions • Have HVAC contractor balance the HRV
Condensation or ice build up in insulated duct to the outside	<ul style="list-style-type: none"> • Incomplete vapor barrier around insulated duct • A hole or tear in outer duct covering 	<ul style="list-style-type: none"> • Tape and seal all joints • Tape any holes or tears made in the outer duct covering, ensure that the vapor barrier is completely sealed
Excess water in the bottom of the HRV	<ul style="list-style-type: none"> • Drain pans plugged • Improper connection of HRV's drain lines • HRV is not level • Drain lines are obstructed • HRV heat exchange core is not properly installed 	<ul style="list-style-type: none"> • Look for obstructions in the drain line • Look for kinks in the drain line
Excessive vibration	<ul style="list-style-type: none"> • Dirt on fan wheels 	<ul style="list-style-type: none"> • Have contractor service HRV

CAUTION: ELECTRICAL CONTROL PANEL, SERVICE BY ELECTRICIAN ONLY

Commercial Wiring Diagram
for Fan Defrost

N.O.	Normally open
N.C.	Normally closed
COM	Common
T#	Terminal
P#	Plug
K#	Relay
F#	Fuse
SW#	Switch

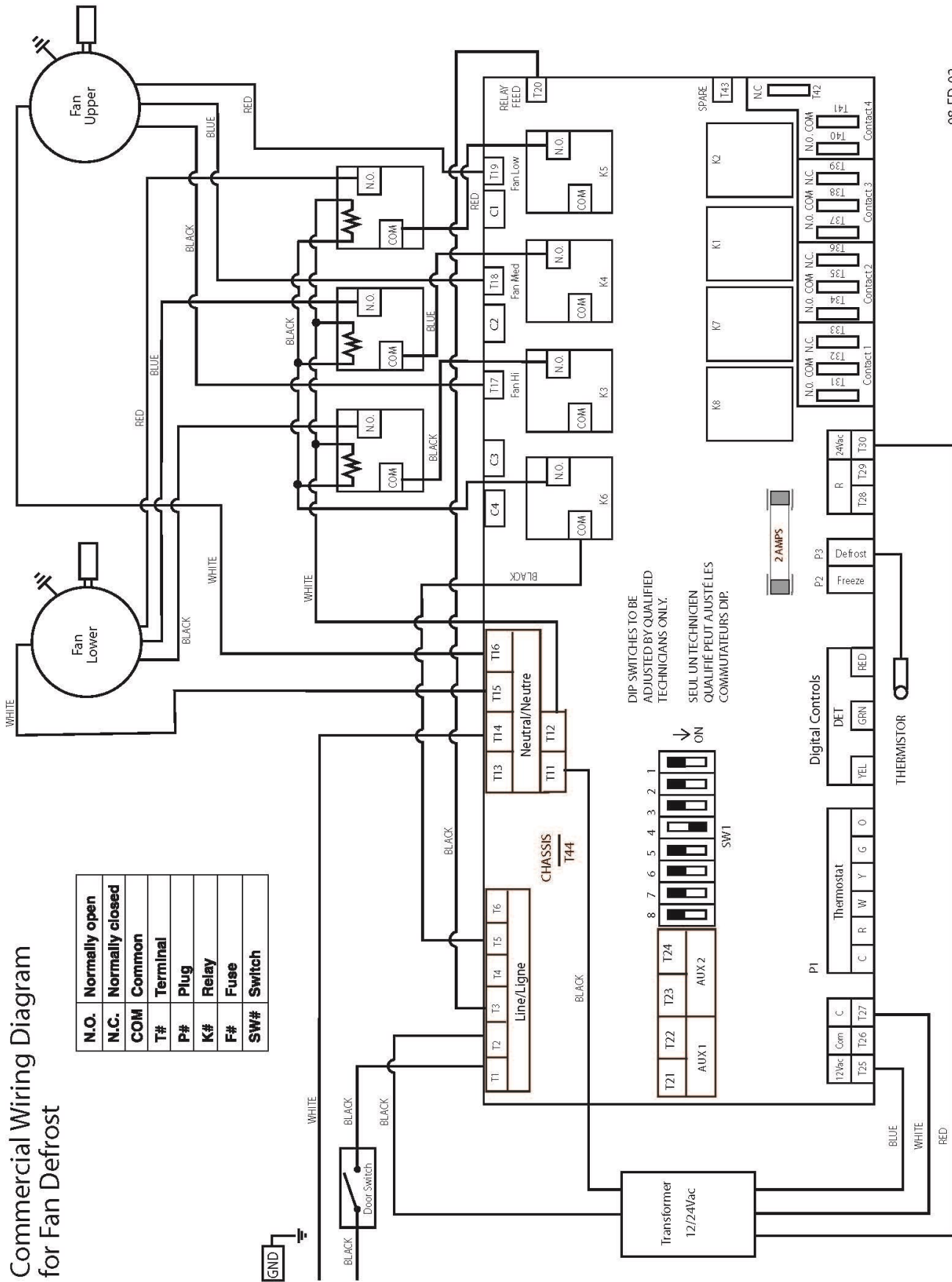

DIP SWITCHES TO BE
ADJUSTED BY QUALIFIED
TECHNICIANS ONLY.
SEUL UN TECHNICIEN
QUALIFIE PEUT AJUSTER LES
COMMUTATEURS DIP.



CAUTION: ELECTRICAL CONTROL PANEL, SERVICE BY ELECTRICIAN ONLY

Commercial Wiring Diagram for Fan Defrost

N.O.	Normally open
N.C.	Normally closed
COM	Common
T#	Terminal
P#	Plug
K#	Relay
F#	Fuse
SW#	Switch

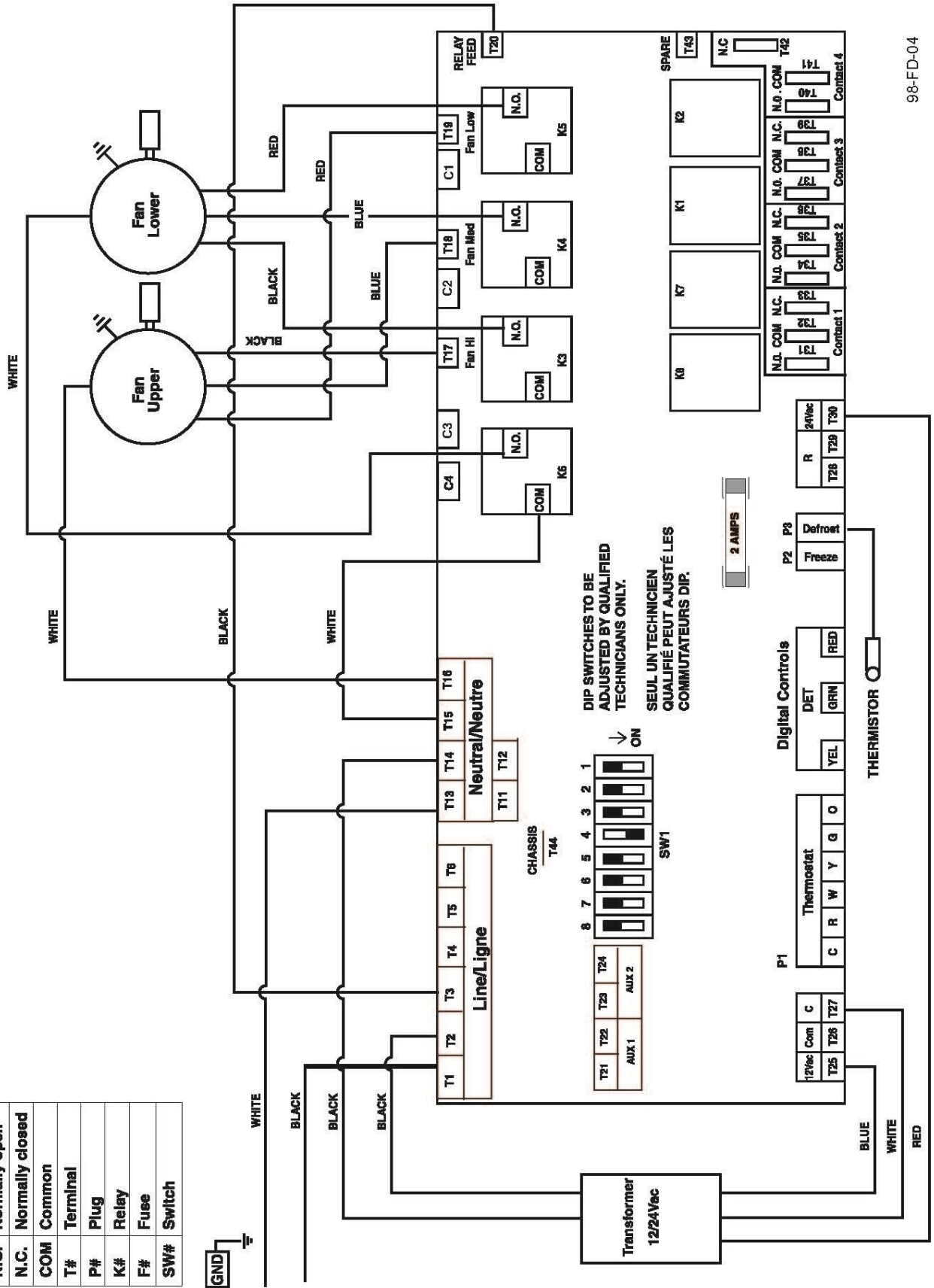

DIP SWITCHES TO BE ADJUSTED BY QUALIFIED TECHNICIANS ONLY.
SEUL UN TECHNICIEN QUALIFIE PEUT AJUSTE LES COMMUTATEURS DIP.

98-FD-04

CAUTION: ELECTRICAL CONTROL PANEL, SERVICE BY ELECTRICIAN ONLY

Commercial Wiring Diagram for Fan Defrost

N.O.	Normally open
N.C.	Normally closed
COM	Common
T#	Terminal
P#	Plug
K#	Relay
F#	Fuse
SW#	Switch

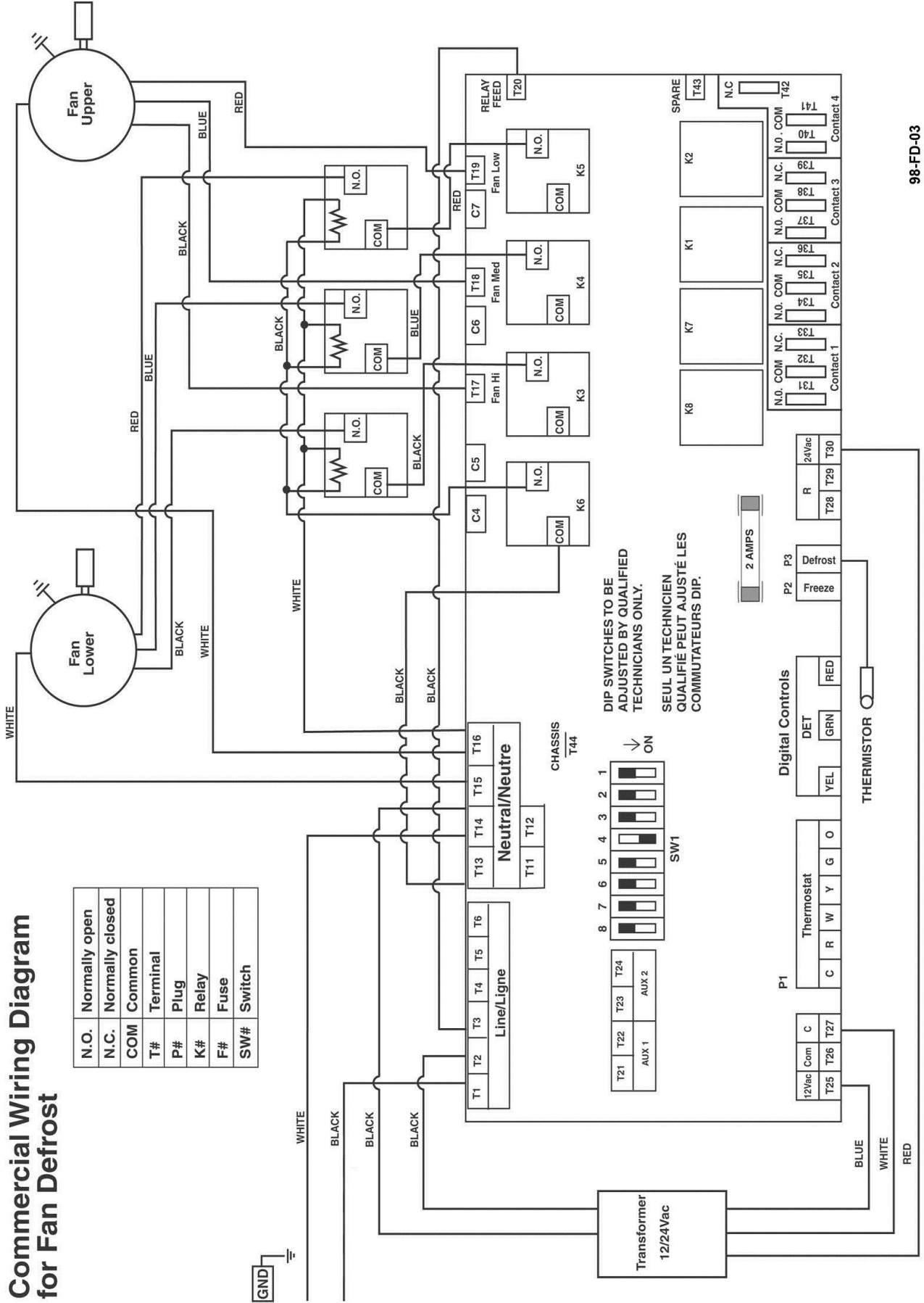

DIP SWITCHES TO BE ADJUSTED BY QUALIFIED TECHNICIANS ONLY.
SEUL UN TECHNICIEN QUALIFIÉ PEUT AJUSTÉ LES COMMUTATEURS DIP.



98-FD-03

CAUTION: ELECTRICAL CONTROL PANEL, SERVICE BY ELECTRICIAN ONLY

Commercial Wiring Diagram for Damper Defrost

N.O.	Normally open
N.C.	Normally closed
COM	Common
T#	Terminal
P#	Plug
K#	Relay
F#	Fuse
SW#	Switch

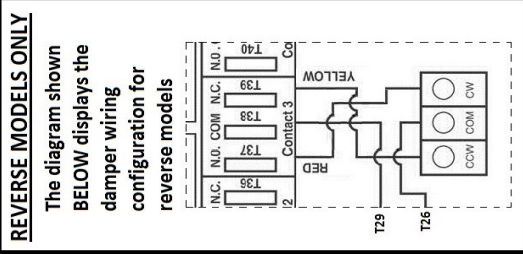
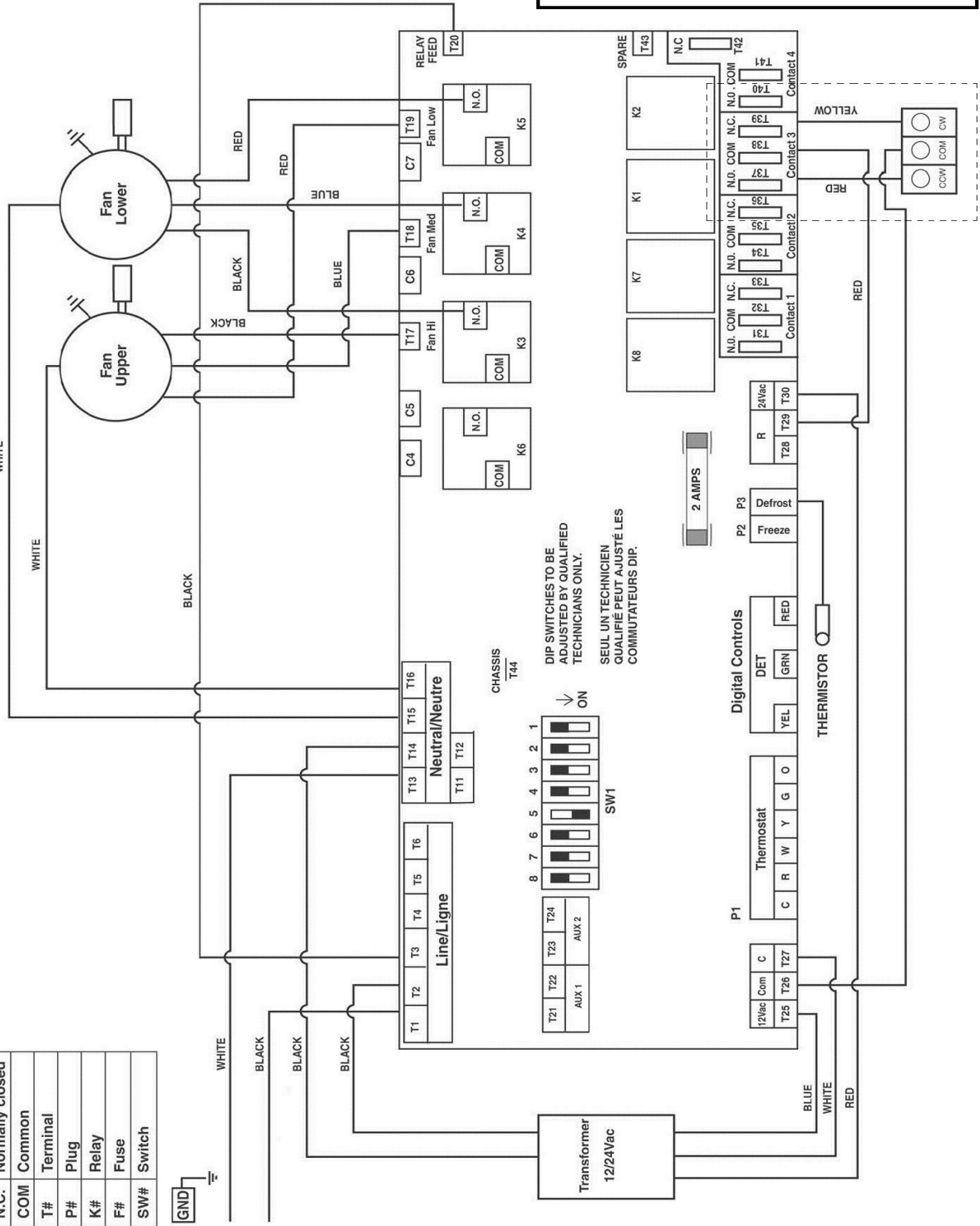

98-DD-02

COMMERCIAL LIFEBREATH® HEAT RECOVERY VENTILATORS

2 Year Limited Warranty • 15 Year HRV Core Warranty

AIRIA BRANDS INC.® (AIRIA) warrants to the original purchaser of the Commercial LIFEBREATH® model and accessories referred to below, to be free from manufacturing defects.

This Warranty is personal to AIRIA® and is in effect from the date of the original purchase for a period of two years, save and except that a 15 YEAR WARRANTY is given to the LIFEBREATH® HRV core should it develop a condensation leak or become damaged during normal use.

Damage resulting from all other causes, including but not limited to: lightning, hurricane, tornado, earthquake or any other acts of God; improper installation, modification, alteration or misuse of the LIFEBREATH® or its operation in a manner contrary to the instructions accompanying the unit at the time of sale; accidental or intentional damage, neglect, improper care, or other failure by the owner to provide reasonable and necessary maintenance of the product; any attempt at repair by an unauthorized service representative or not in accordance with this warranty; or any other causes beyond the control of AIRIA®, are excluded from this warranty.

If you feel that the LIFEBREATH® you purchased is not free from manufacturing defects, please contact AIRIA BRANDS INC.®, 511 McCormick Blvd., London, Ontario N5W 4C8, 519-457-1904 or fax 519-457-1676 to find the name of your nearest dealer in order to repair the product. The labour required to install any replacement part(s) shall be dealt with at the option of the customer in either of the following ways:

- a) the customer may supply labour at their own expense: or
- b) if the product was purchased from a dealer, then the dealer may supply labour at cost to the customer.

AIRIA® reserves the right to replace the entire unit or to refund the original purchase price in lieu of repair.

AIRIA® MAKES NO EXPRESS WARRANTIES, EXCEPT FOR THOSE THAT ARE SET FORTH HEREIN AND SHALL NOT BE LIABLE FOR ANY INCIDENTAL, SPECIAL OR CONSEQUENTIAL DAMAGES WITH RESPECT TO LIFEBREATH® COVERED BY THIS WARRANTY. AIRIA'S COMPLETE LIABILITY AND THE OWNER'S EXCLUSIVE REMEDY BEING LIMITED TO REPAIR OR REPLACEMENT ON THE TERMS STATED HEREIN. ANY IMPLIED WARRANTIES, INCLUDING BUT NOT LIMITED TO THE IMPLIED WARRANTY OF MERCHANTABILITY AND OF FITNESS FOR ANY PARTICULAR PURPOSE, ARE EXPRESSLY EXCLUDED.

NO PERSON IS AUTHORIZED TO CHANGE THE WARRANTY IN ANY WAY OR GRANT ANY OTHER WARRANTY UNLESS SUCH CHANGES ARE MADE IN WRITING AND SIGNED BY AN OFFICER OF AIR-IA®.

MODEL NO.: _____

UNIT SERIAL NO.: _____

INSTALLED BY: _____

DATE: _____



511 McCormick Blvd.
London, Ontario N5W 4C8
T 1-855-247-4200
F 1-800-494-4185
Email: info@lifebreath.com

270 Regency Ridge, Suite 210
Dayton, Ohio 45459
T (937) 439-6676
F (937) 439-6685
Website: www.lifebreath.com



69-ComHRV

011118