

ENGINEERING DATA

TOTAL RECOVERY CORE

The cross-flow energy recovery core transfers heat and water vapor between the two airstreams. It is easily removed for cleaning or service.

MOTORS AND BLOWERS

Each airstream has an independent motorized impeller, with multiple fan speed operation.

FILTERS

Washable pre filters in exhaust and supply airstreams.

MOUNTING THE ERV

Hanging straps supplied with the unit.

FROST PREVENTION

Temperature sensor activated, periodically shuts down supply motor. Drains not required.

CASE

20 gauge prepainted galvanized steel for superior corrosion resistance, insulated to prevent exterior condensation.

INSTALLER SELECTABLE HIGH SPEED SETTINGS

The highest speed, "H3" is the factory setting. Installers may select a lower high speed on set up. See chart for airflows H1, H2, and H3.

ELECTRONICS

The main control can be wall mounted in a central location. 3 wire 20 gauge (min.) 100 ft length (max.).

CONTROL OPTIONS

99-DXPL02 Lifebreath Digital Control

- 5 speed operation on each mode
- Humidity control through adjustable Dehumidistat
- 5 user selectable operational modes: Continuous Ventilation, Continuous Recirculation, 20 ON/40 OFF, 10 ON/50 OFF, 20 ON/40 Recirculation
- 20/40/60 min. High speed override button
- Compatible with 99-DET02 Wireless Timers
- 3 wire connection

99-BC04 Lifebreath Ventilation Control

- 2 speed fan setting (Low/High)
- 2 modes of operation: Ventilation, 20/40
- Compatible with 99-DET02 Wireless Timers
- 3 wire connection

TIMER OPTIONS

99-DET01 Lifebreath 20/40/60 Minute Timer - Initiates High speed Ventilation for 20, 40 or 60 minutes. 3 wire connection.

99-DET02 WIRELESS Lifebreath 20/40/60 Minute Timer - Initiates High speed Ventilation for 20, 40 or 60 minutes. Wirelessly connects to main control for ease of installation. 40' approximate range.

99-RX02 WIRELESS Repeater - Used to extend range of 99-DET02 Wireless Timers. Plugs into 120V power outlet. Wirelessly connects to main control and 99-DET02. Install at halfway point between timer and main wall control if timer is out of range.

ACCESSORY OPTIONS

99-163 Duct Heater w/Electronic SCR Thermostat - 1 kW, 6 in (152 mm)

99-186 Weatherhoods - Two 6 in (152 mm)

Performance (HVI certified)		
Net supply airflow in cfm (L/s) against external static pressure		
External Static Pressure	Airflow	
@ 0.1 in (25 Pa)	209 cfm (99 L/s)	
@ 0.2 in (50 Pa)	194 cfm (92 L/s)	
@ 0.3 in (75 Pa)	184 cfm (87 L/s)	
@ 0.4 in (100 Pa)	170 cfm (80 L/s)	
@ 0.5 in (125 Pa)	154 cfm (73 L/s)	
@ 0.6 in (150 Pa)	137 cfm (65 L/s)	
@ 0.7 in (175 Pa)	125 cfm (59 L/s)	
@ 0.8 in (200 Pa)	108 cfm (51 L/s)	
@ 0.9 in (225 Pa)	93 cfm (44 L/s)	
@ 1.0 in (250 Pa)	78 cfm (37 L/s)	
Max. Temperature Recovery		87%
Sensible Effectiveness		
@ 64 cfm (30 L/s)	32°F (0°C)	87%
Total Efficiency		
@ 64 cfm (30 L/s)	95°F (35°C)	53%
VAC @ 60Hz		120
Watts / Low speed		64
Watts / High speed		96
Amp rating		1.4

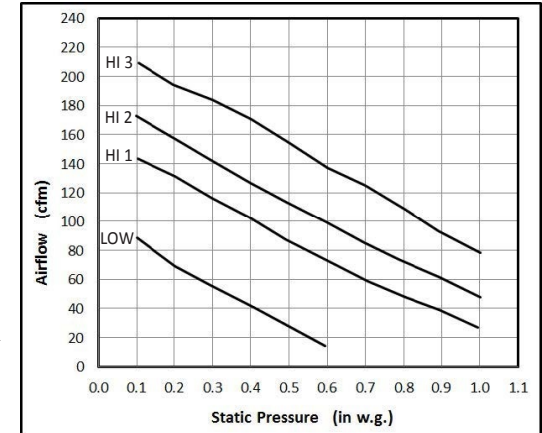

Total Efficiency: Moisture and Thermal @95F

Effectiveness: Based on temperature differential between the 2 airstreams



All units conform to CSA and UL standards

DIMENSIONS 230 ERV

WEIGHT 75 lbs (34 kg) **SHIPPING WEIGHT** 77 lbs (35 kg)

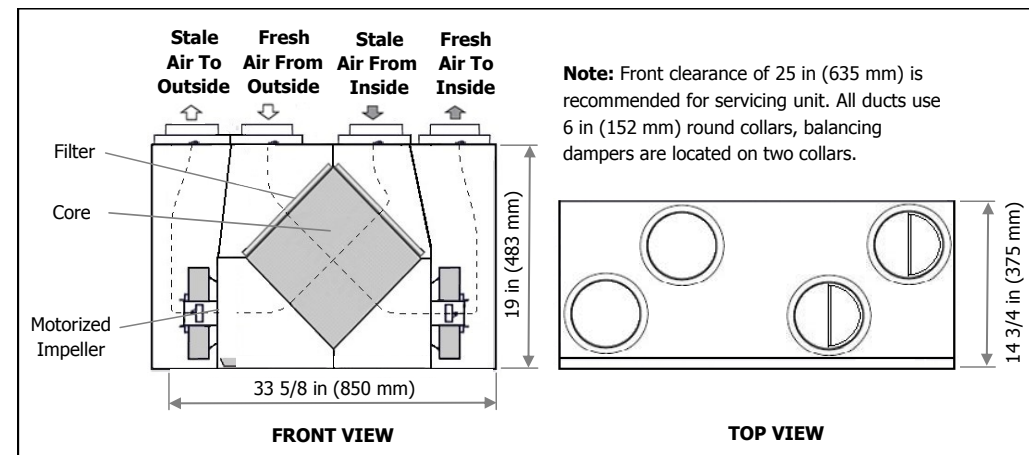

NOTE: All specifications are subject to change without notice.

WARRANTY

Units carry a 10 year warranty on the ERV core and a 5 year replacement parts warranty.

Date: _____ Contractor: _____

Tag: _____ Qty: _____ Supplier: _____

Project: _____ Quote #: _____

Engineer: _____ Submitted By: _____