

## Multimedia Outlet System Fiber Storage/Spacer Ring

### APPLICATION

The Multimedia Outlet System (MOS) Fiber Storage/Spacer Ring provides cable management and bend radius protection behind dual-gang flush-mount MOS wallplates and surface-mount boxes.

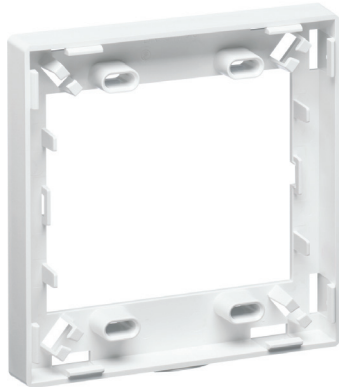

### SPECIFICATION

The fiber cable storage/spacer ring shall mount behind a front-load double-gang wallplate or on top of dual-gang surface-mount box to provide 0.6-inch extra depth and a guided cable path in support of ANSI/TIA-568-C bend radius requirements. Capacity shall be two 1-meter lengths of 900-micron-jacketed fiber optic cable, managed by side tabs and corner 'C' clips. The storage ring shall be made of high-impact self-extinguishing ABS plastic. Tie-wrap areas must be provided to allow the installer to anchor the fiber where it first enters the ring, and secure it again when fully coiled. Colors and configurations to be specified per schedule on plan.

### FEATURES

- Fiber coil bend radius is guided and protected by side tabs and corner 'C' clips
- Slotted mounting holes let installers level the ring if backbox is crooked

### DESIGN CONSIDERATIONS

- Ring is for fiber cable only
- Adds 0.6-inch depth to the wallplate and provides .5-inch wire management pathway
- Can store two 1-meter lengths of 900-micron-jacketed fiber optic cable
- Mounts to standard dual-gang NEMA openings, or foursquare boxes with appropriate reducer/adaptor

### INSTALLATION NOTES

- The plate attaches with screws to wallbox or backbox
- Inserts snap in/out of wallplate from front
- Self-leveling feature allows adjustment
- Limit wire untwisting to 0.5 inches from termination point
- Limit cable jacket removal to a minimum
- Observe cable manufacturer's recommended bend radius
- 1.5-unit angled QuickPort® modules used in the top half of the wallplate may result in an interference when using fiber connectors and the fiber storage ring

### STANDARDS COMPLIANCE

- ANSI/TIA-568-C
- cULus listed (UL1863, CAN/CSA C22.2 No. 182.4-M90)

### PHYSICAL SPECIFICATIONS

- Capacity: Two 1-meter lengths of 900-micron-jacketed fiber optic cable
- Materials: High-impact self-extinguishing ABS plastic rated UL 94V-0
- Dimensions: See page two

### COUNTRY OF ORIGIN

USA

### WARRANTY INFORMATION

For warranty information go to [leviton.com/warranty](http://leviton.com/warranty)  
[www.leviton.com/warranty](http://www.leviton.com/warranty).

41290-DRx

**ELECTRONIC FILES**

For CAD files, typical specs, or technical drawings (.DXF, .DWG), visit [www.leviton.com](http://www.leviton.com).

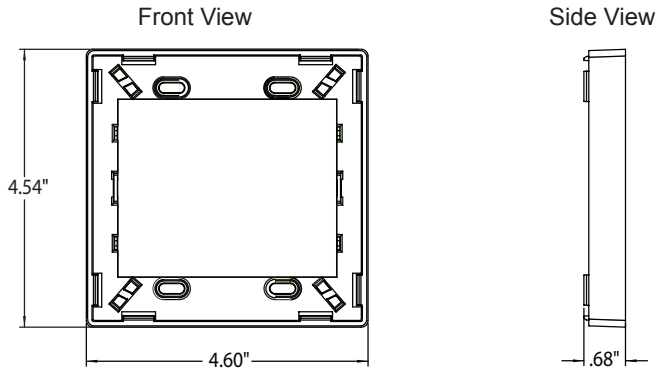

**41290-DRx**

**MOS Fiber Storage/Spacer Ring**

Description	Part No.
Dual-Gang, White	41290-DRW
Dual-Gang, Ivory	41290-DRI
Dual-Gang, Grey	41290-DRG
Dual-Gang, Black	41290-DRE