

Smart Wallbox Sensors: 15A Switching ON/OFF

Cat. No. ODS15-ID

LEVITON®

PK-A3316-10-00-2A

WARNINGS

- **TO AVOID FIRE, SHOCK, OR DEATH; TURN OFF POWER AT CIRCUIT BREAKER OR FUSE AND TEST THAT POWER IS OFF BEFORE WIRING!**
- To be installed and/or used in accordance with appropriate electrical codes and regulations.
- If you are unsure about any part of these instructions, consult an electrician.

CAUTION

- For indoor applications only.

SAVE THESE INSTRUCTIONS.

INSTALLATION INSTRUCTIONS

ENGLISH

Product Description

Leviton Cat. No. ODS15-ID, Wall Switch Occupancy Sensor, uses Passive Infrared (PIR) detection technology to monitor a room for occupancy through a segmented lens. This specialized lens divides the field of view into sensor zones. When a person passes into or out of a sensor zone, the sensor detects motion and switches the lights ON. The lights will remain ON as long as there is an occupant moving through the sensor zones. ODS15-ID can also be programmed to vacancy mode (Manual ON/Auto OFF) for installations where manual ON switching is required for Title 24 applications. The ODS15-ID provides a 180° field of view with a maximum coverage area of approximately 1100 square feet. The maximum sensing distance in front of the sensor is 30-40 feet, and 15-20 feet on either side. A "minor motion" zone detects small body movements and allows the lights to stay ON even though a person may not be moving or walking around the room. The remainder of the field of view, the "major motion" zone, exhibits a lesser degree of sensitivity and requires larger movements. Simple configuration can also be applied using push-button setup for several popular preconfigured options. ODS15-ID is also equipped with a photocell for daylighting which is programmable using the Leviton Smart Sensor App.

Before Installation

- Installs into standard single gang wall boxes.
- Supports multi-gang installations.
- Ivory, light almond, black, red, and gray faceplates are available with a color change kit (sold separately).
- Decora® wallplate not included.
- Controls lighting loads and plug load control up to 15A.

FOR OPTIMAL PERFORMANCE:

The ODS15-ID sensor lens establishes dozens of zones of detection. The sensor is sensitive to the heat emitted by the human body. In order to trigger the sensor, the source of heat must move from one zone of detection to another. The device is most effective in sensing motion across its field of view, and less effective sensing motion towards or away from its field of view. Keep this in mind when selecting the installation location. Note that occupancy sensors respond to rapid changes in temperature, so care should be taken NOT to mount the device near a climate control source (i.e., radiators, air exchanges, and air conditioners). Hot or cold drafts will look like body motion to the device and will trigger it if the unit is mounted too close. It is recommended to mount the occupancy sensor at least 6 ft away from a climate control source. In addition, it is also recommended NOT to mount the occupancy sensor directly under a large light source. Large wattage bulbs (greater than 100W incandescent) give off a lot of heat and switching the bulb causes a temperature change that can be detected by the device. Mount the occupancy sensor at least 6 ft away from large bulbs. If it necessary to mount the device closer, lower the wattage of the bulb directly overhead.

Horizontal Beam Diagram

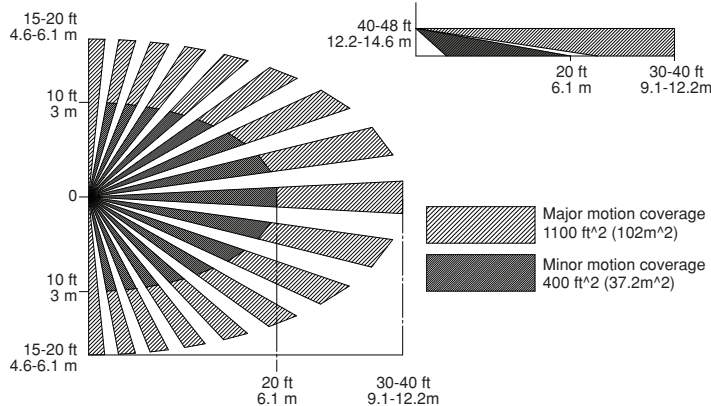

Installation

WARNING: TO AVOID FIRE, SHOCK, OR DEATH; TURN OFF POWER at circuit breaker or fuse and test that power is off before wiring!

1. Strip wires 3/4 in and connect as per wiring diagram. Ensure wires are firmly attached and there is no exposed copper.

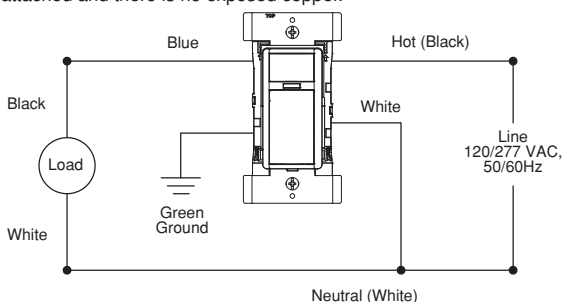

2. Gently place the wires and your device into the wall box and attach with screws provided.
3. If desired, change switch color. (Sold separately.)
4. Restore power and test ON/OFF operation. Locator light should be ON when switch is in the OFF state.
5. Install Decora wallplate (not included).
6. ODS15-ID is designed to work and be fully functional right out of the box, settings can be adjusted using the Leviton Smart Sensor App or simple push button programming.

7. Using the Leviton Smart Sensor App or push button programming, you can now configure the sensor to your preferred settings. (Leviton Smart Sensor App, downloadable from Google Play™ or the Apple App Store®, using any Bluetooth™ enabled Android™ or iOS Device). Operating mode, sensor sensitivity, and sensor timeout can be quickly adjusted. For more advanced settings such as daylighting and nightlight configuration, the Leviton Smart Sensor App will need to be used for setup and adjustments.

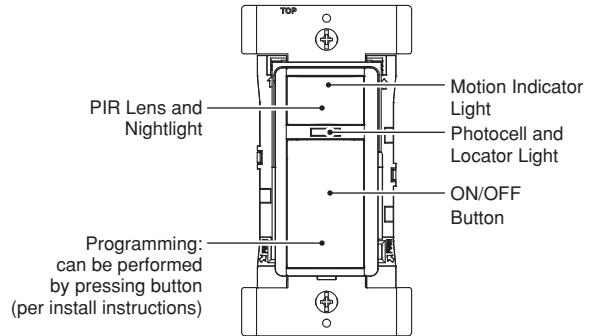

Operation

PUSH-BUTTON: ODS15-ID has a push button switch that will toggle the lights ON or OFF. When mode is set to Auto ON / Auto OFF, the lights will automatically turn ON when occupancy is detected and will turn OFF automatically after occupancy is no longer detected and the timeout has expired. If mode is set to Manual ON / Auto OFF, the lights will only turn ON when the push button switch is pressed; the lights will turn OFF automatically after occupancy is no longer detected and the timeout has expired. If the lights are ON, the lights can be turned OFF when the button is pressed. The lights will stay OFF (regardless of motion detected) until the timeout expires. After the timeout expires, the lights will turn ON when the next motion is detected. This is useful for slide or film presentations.

NOTES:

- The Motion Indicator light will blink RED for 1 second each time motion is detected.
- In Manual ON mode, the button must be pressed to turn the lights ON. In the absence of motion, the unit will time out and turn the lights OFF.

Configuration and Programming

1. The ODS15-ID Sensor is designed to work out of the box in default settings. Changes to these settings and additional product configuration can be performed using the Leviton Smart Sensor App, downloadable from Google Play™ or the Apple App Store®, using any Bluetooth™ enabled Android™ or iOS Device.
 - a. To pair to device using the Leviton Smart Sensor App:
 - i. Press and hold the ON/OFF button for 2-5 seconds; when the light behind the PIR lens blinks BLUE, release the button.
 - ii. Open the Leviton Smart Sensor App and connect to the device.
 - iii. The device can also be found by scanning for nearby devices; devices can be identified in the app to confirm you are connected to the right sensor.
 - b. Use the Leviton Smart Sensor App to:
 - i. Set operating mode to Auto ON / Auto OFF (default) or Manual ON / Auto OFF.
 - ii. Adjust the sensitivity of the sensor to increase or decrease field of view coverage area pending the room size (100% for larger spaces approaching 1100 sq ft).
 - iii. Adjust timeouts (amount of time lights/load will turn OFF after occupancy is no longer detected).
 - iv. Activate the night light and its operating mode; selection of custom night light color.
 - v. Add daylighting and select target levels for daylighting.
 - vi. Set a security code to lock configuration.
 - vii. See Leviton Smart Sensor App for additional settings and other programming options.
2. If the installer does not have access to a Bluetooth enabled Android or iOS Device, popular preset product configuration can also be made using simple push button commands:
 - a. If wall plate is attached, remove first. With the wallplate removed, pinch sides of sensor near bottom tabs to release front cover of sensor.

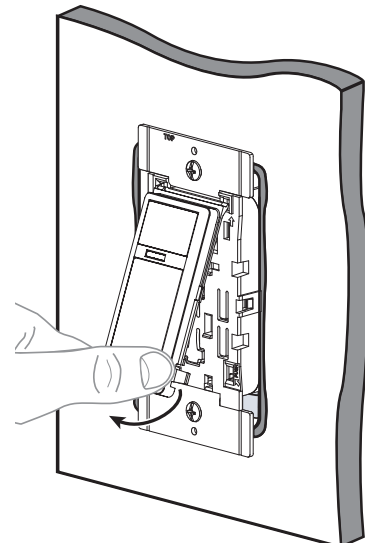

- b. With the front faceplate of the sensor removed, push both buttons on front of sensor simultaneously for 10-15 seconds (note: after 5 seconds, a light will blink BLUE and then alternate between BLUE and RED) and release when the Locator Light is blinking GREEN.

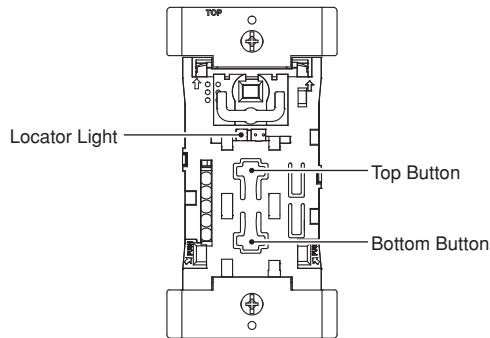

- c. Push the bottom button to move to the next automatic setting using the table below as a guide.
 d. When at the desired setting, press and hold the bottom button again for 5 seconds (until the GREEN LOCATOR light turns ON), when the button is released, the light will flash the number of times as the setting selected; the sensor is now saved in that configuration.
 e. The front cover can now be reattached. Insert the top tabs and push in bottom tabs to attach.

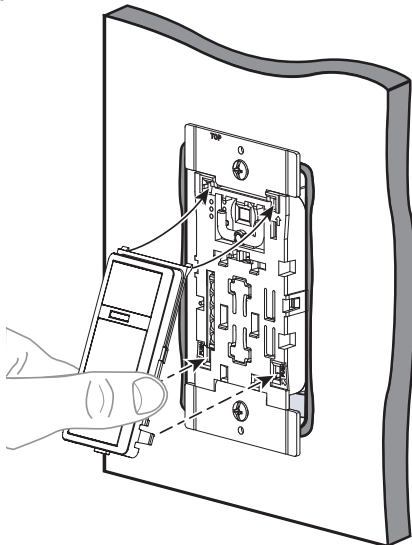

NOTES:

- Use the number of light blinks to determine which user mode the sensor is set to.
 If pressed more than 8 times, it will cycle back to the start of the list.
- Auto ON/Auto OFF (10 min timeout and 1 button press) is the DEFAULT MODE.

- 3. Daylighting and Night Light:** The ODS15-ID is equipped with a photocell for daylighting and also has a built in night light that can be turned ON and configured using the Leviton Smart Sensor App.
- 4. Bluetooth Reset:** Resets any security settings but preserves lighting and mode settings.
- Push button on switch for approximately 20-25 seconds until the light behind PIR lens is flashing RED.
NOTE: after 5 seconds, light behind PIR lens will blink BLUE and then alternate between BLUE and RED; at 10-15 seconds will then blink GREEN.
 - When the light flashes RED, release the button.
 - The device will reset and turn off when complete.
 - When device turns back on it will have no password set.

Troubleshooting

- If sensor does not trigger when entering the room or space, increase the sensitivity level of the sensor and/or check the daylighting settings (increase the daylighting level).
- If the lights constantly stay ON even when room is unoccupied:
 - Check the Time Out setting and confirm set to desired time.
 - Try lowering the sensor sensitivity; if problem persists, try lowering again.
 - Check for reflected heat/motion as sensor may be seeing motion through a window.
 - Check for adjacent HVAC and/or heater ducts.

Statement Caution

Changes or modifications not expressly approved by Leviton Manufacturing Co., could void the user's authority to operate the equipment.

FCC COMPLIANCE STATEMENT:

This equipment has been tested and found to comply with the limits for a Class B digital device, pursuant to part 15 of the FCC Rules. These limits are designed to provide reasonable protection against harmful interference in a residential installation. This equipment generates, uses and can radiate radio frequency energy and, if not installed and used in accordance with the instructions, may cause harmful interference to radio communications. However, there is no guarantee that interference will not occur in a particular installation. If this equipment does cause harmful interference to radio or television reception, which can be determined by turning the equipment off and on, the user is encouraged to try to correct the interference by one or more of the following measures: Reorient or relocate the receiving antenna.

- Increase the separation between the equipment and receiver.
- Connect the equipment into an outlet on a circuit different from that to which the receiver is connected.
- Consult the dealer or an experienced radio/TV technician for help.

IC STATEMENT

This device complies with Industry Canada license-exempt RSS standard(s). Operation is subject to the following two conditions: (1) this device may not cause interference, and (2) this device must accept any interference, including interference that may cause undesired operation of the device.

Trademark Disclaimer

The Leviton logo and Decora are registered trademarks of Leviton Manufacturing Co., Inc. Google Play and Android are trademarks of Google, LLC. The Apple App Store is a registered trademark of Apple, Inc. Bluetooth is a trademark of Bluetooth SIG, Inc. Use herein of other third party trademarks, service marks, trade names, brand names and/or product names are for informational purposes only, are/may be the trademarks of their respective owners; such use is not meant to imply affiliation, sponsorship, or endorsement. No part of this document may be reproduced, transmitted or transcribed without the express written permission of Leviton Manufacturing Co., Inc.

RF EXPOSURE AND CO-LOCATION:

To comply with FCC OET Bulletin 65 and ISED RF exposure limits for general population / uncontrolled exposure this device should be installed and operated with a minimum distance of 7.9 inches (20 cm) between the radiator and your body. This transmitter must not be co-located or operated in conjunction with any other antenna or transmitter.

FCC SUPPLIERS DECLARATION OF CONFORMITY

Smart Wallbox Sensors manufactured by Leviton Manufacturing, Inc., 201 N Service Road, Melville, NY, http://www.Leviton.com. This device complies with part 15 of the FCC Rules. Operation is subject to the following two conditions: (1) This device may not cause harmful interference, and (2) this device must accept any interference received, including interference that may cause undesired operation.

FOR CANADA ONLY

For warranty information and/or product returns, residents of Canada should contact Leviton in writing at Leviton Manufacturing of Canada Ltd to the attention of the Quality Assurance Department, 165 Hymus Blvd, Pointe-Claire (Quebec), Canada H9R 1E9 or by telephone at 1 800 405-5320.

LIMITED 5 YEAR WARRANTY AND EXCLUSIONS
 Leviton warrants to the original consumer purchaser and not for the benefit of anyone else that this product at the time of its sale by Leviton is free of defects in materials and workmanship under normal and proper use for five years from the purchase date. Leviton's only obligation is to correct such defects by repair or replacement, at its option. For details visit www.leviton.com or call 1-800-824-3005. This warranty excludes and there is disclaimed liability for labor for removal of this product or reinstallation. This warranty is void if this product is installed improperly or in an improper environment, overloaded, misused, opened, abused, or altered in any manner, or is not used under normal operating conditions or not in accordance with any labels or instructions. There are no other or implied warranties of any kind, including merchantability and fitness for a particular purpose, but if any implied warranty is required by the applicable jurisdiction, the duration of any such implied warranty, including merchantability and fitness for a particular purpose, is limited to five years. Leviton is not liable for incidental, indirect, special, or consequential damages, including without limitation, damage to, or loss of use of, any equipment, lost sales or profits or delay or failure to perform this warranty obligation. The remedies provided herein are the exclusive remedies under this warranty, whether based on contract, tort or otherwise.

SPECIFICATIONS	
Input Voltage/Frequency	120-277VAC, 50/60Hz
Input Current	
120V	Standby: 0.2W Max: 0.5W+Load Current
277V	Standby: 0.3W Max: 0.6W+Load Current
Load Ratings	
General Purpose @ 120V	20A
General Purpose @ 277V	20A
LED, CFL, Electronic Ballast @ 120V	10A
LED, CFL, Electronic Ballast @ 277V	10A
Magnetic Ballast @ 120V	10A
Magnetic Ballast @ 277V	10A
Resistive, Tungsten @ 120V	6.67A
Resistive, Tungsten @ 277V	6.67A
Motor @ 120V	1/4Hp (FLA 5.8A)
Motor @ 277V	1/3Hp (FLA 3.0A)
IP Rating	IP10
Network Connections	BLE 5.0
Operating Temperature	0°C to 40°C (32°F to 104°F)
Storage Temperature	-40°C to 85°C (-40°F to 185°F)
Purpose of Control	Energy Management Equipment
Action Control Type	1
Pollution Degree	2
Impulse Voltage	4000V

INDICATOR LIGHT DESCRIPTIONS		
LED	Location	Action / Definition
RED	Behind PIR Lens	Blinks ON for 1 second upon PIR detection
RED	Behind PIR Lens	Blinking RED: Device in Bluetooth reset; continues until reset is complete then stops
BLUE	Behind PIR Lens	Blinking BLUE LED: Device BLE in Pairing Mode
BLUE / RED	Behind PIR Lens	Alternating BLUE/RED: Device in Installation/Test Mode (Factory Only)
GREEN	Behind PIR Lens and Locator	GREEN light behind PIR lens / Locator LED blinking according to Menu Mode: Device is in Manual Configuration mode, number of LED blinks shows which mode device is in
GREEN	ALL	Blinking GREEN LEDs indicates device is in identify mode
GREEN / BLUE	Behind PIR Lens	Alternating GREEN/BLUE during 1 minute Daylight Calibration
GREEN / BLUE	Behind PIR Lens	GREEN/BLUE blinks for 2 seconds every 30 seconds when Daylighting is active

Button Press	Locator Light Blinks	Operating Mode	Sensor Sensitivity	Timeout	Daylighting and Night Light
1 *Default Operation	1	Auto ON / Auto OFF	75%	10mins	OFF & OFF
2	2	Auto ON / Auto OFF	75%	20mins	OFF & OFF
3	3	Auto ON / Auto OFF	100%	10mins	OFF & OFF
4	4	Auto ON / Auto OFF	100%	20mins	OFF & OFF
5	5	Manual ON / Auto OFF	75%	10mins	OFF & OFF
6	6	Manual ON / Auto OFF	75%	20mins	OFF & OFF
7	7	Manual ON / Auto OFF	100%	10mins	OFF & OFF
8	8	Manual ON / Auto OFF	100%	20mins	OFF & OFF

ARTWORK PRINT SPECIFICATIONS



PART NUMBER PK-A3316-10-00-2A **REV** _____ **DESCRIPTION** Instruction Sheet

SPECIFICATIONS :

- * Artwork must be printed at 100% (1:1 scale)
- * Thickness: 40 lb. _____
- * Material: _____
- * Finish: _____
- _____ :
- * For manuals - designates cover specifications

- * Color(s): 1 over 1
- 1: Black Spot
- 2: _____ CMYK
- 3: _____
- 4: _____

- * Fonts:
- 1: Helvetica _____
- 2: _____
- 3: _____
- 4: _____

Die Line Key: - . . . - Perforate
 _____ Die Cut - - - - - Fold Line - - - - - Kiss Cut ::::: Cellophane ||||| Glue

MANUAL INTERIORS / BINDERY / FOLD SCHEME :

- Body Material: _____
- Thickness: _____
- Bindery
- Die cut Fold Saddle Stitch
- Perfect Bind Drill Trim

- Color(s): _____ over _____
- 1: _____ Spot
- 2: _____ CMYK
- 3: _____
- 4: _____

- Fonts:
- 1: _____
- 2: _____
- 3: _____
- 4: _____

PROCESS :

- Offset Flexo
- Other _____
- Line Screen: _____
- Angle: _____
- Resolution: _____

DIMENSIONS / FOLD SCHEME / BINDERY DIAGRAM

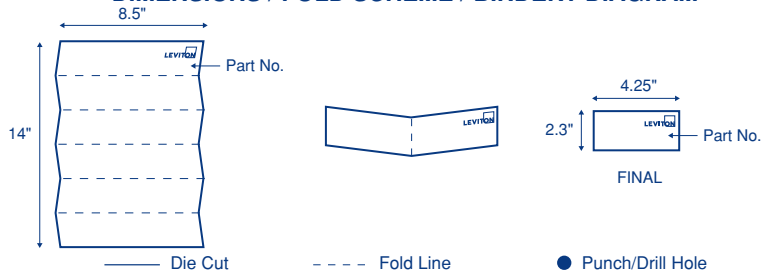

COMMENTS :

The information in this document is the exclusive PROPRIETARY property of LEVITON MANUFACTURING COMPANY, INC. It is disclosed with the understanding that acceptance or review by the recipient constitutes an undertaking by the recipient. (1) to hold this information in strict confidence, and (2) not to disclose, duplicate, copy, modify or use the information for any purpose other than that for which disclosed.

FOR LEVITON USE ONLY

- Approvals: Plant 08 J. Tang cc: H. Cai CQA _____ PM R. Parks cc: L. Pukhrbamb
- Mktg _____ Eng L. Huang S & A D. Moskovkin cc: F. Tse
- Cust _____ Other M. Blonder Other V. LoNigro

PN-ARN: EM0303-6292 ECR Number: _____ Pilot Rev: X7

Artist: L. Walsh/Z. Reisman Released Artwork Format: Production PDF Artwork Release Date: 05/28/20

Notes: _____