

INSTALLATION ADJUSTMENT SERVICE PROTON VALVE

IMPORTANT! Provide serial number when ordering parts!!

INSTALLATION



WARNING: This product can expose you to chemicals including lead, which is known to the State of California to cause cancer. For more information, go to www.P65Warnings.Ca.gov



**INSTALLATION AND FIELD ADJUSTMENTS ARE THE
RESPONSIBILITY OF INSTALLER. READ ALL
INSTRUCTIONS PRIOR TO INSTALLATION**



- | | |
|--|---|
| <ol style="list-style-type: none">1. Leonard Proton Valves are factory pre-assembled and tested and include digital mixing valve and controls which function as a system to meet both high and low demand for tempered water.2. System should be installed at a location where it can easily be cleaned, adjusted or repaired.3. System supplies must be connected as shown (Hot-left, Cold-right). Exercise caution when soldering. | <ol style="list-style-type: none">4. Flush pipes thoroughly after system has been connected.5. This assembly MUST be piped according to LEONARD'S REQUIRED PIPING METHOD W.6. Refer to pages 2-3 of this bulletin for correct Setup Instructions. |
|--|---|

Model PNV-100-LF – 3/4" Inlets, 1" Outlet

Model PNV-125-LF – 1" Inlets and 1.25" Outlet

Model PNV-150-LF – 1.25" Inlets, 1.5" Outlet

Model PNV-200-LF – 2" Inlets and 2" Outlet

Maximum Operating Pressure 200PSI (13.8 BAR) for Hot and Cold Water.

Hot Water Temperature Range: 120° - 180°F (49° - 82°C)

Cold Water Temperature Range: 39° - 80°F (4° - 27°C)

Temperature Adjustment Range: 65° - 180°F (18° - 82°C)

1360 Elmwood Avenue, Cranston, RI 02910 USA

Phone: 401.461.1200 Fax: 401.941.5310

Email: info@leonardvalve.com

Web Site: <http://www.leonardvalve.com>

SETUP INSTRUCTIONS

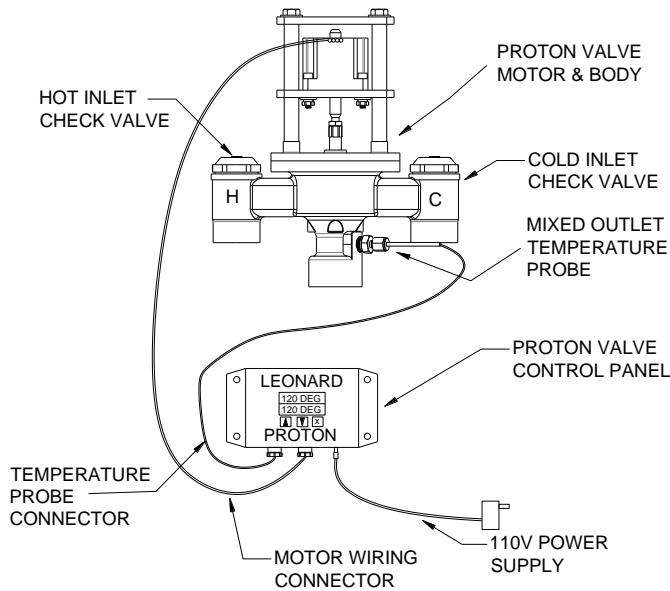

The Proton Control Box has a 2 Line, 16 character LED digital display screen, which serves as the User Interface by utilizing a simple 3-button keypad interface: ▲, ▼ and ENTER, to change temperature see page 4.

On Initial Power up, the valve will go through a full sweep function, which moves the motor its full travel, end-to-end of hot and cold ports of the valve body. This process assigns a numerical value to the distance travelled by the motor, in steps, that will be used in future comparisons to indicate if there is a potential maintenance problem or internal mechanical issue with the components of the valve



WARNING



The Leonard Proton Digital Mixing Valve is an electronically controlled device utilizing DC circuitry. The connection of the Electronic Control Box to the Mechanical Valve Components is very simple. There is a 3-wire RTD Temperature Probe as well as a 4-wire Motor Harness that must be connected and plugged into the box on the left and middle (respectively) connection points on the bottom of the Control Box. The 110V Power to the box is accomplished through the barrel connector on the bottom right side of the Control Box. Installer must follow detailed instructions below to ensure proper operation of valve.



•NOTE! READ ALL INSTRUCTIONS PRIOR TO INSTALLATION



•NOTE! FOR RECIRCULATION PIPING ARRANGEMENT, SEE PAGE 10

INSTALLATION INSTRUCTIONS

1. The Proton Unit MUST be piped according to Leonard Required Piping Method W (see page 10).
2. Mount valve body and plumb inlet and outlet connections. DO NOT introduce water to the valve until completion of these instructions.
3. Mount Proton Control Box to desired location, within 6' of Valve Body using suitable screws at 4-hole locations on Control Box. Ensure all wiring connected to the Control Box is accessible.
4. Remove compression fitting from rear-right side of the valve outlet. Slide RTD Probe #1 through the compression fitting and insert into the rear-right side of the valve outlet. Tighten compression fitting by hand, and then tighten just 1/8 to 1/4 turn. DO NOT overtighten fitting. See page 9 for more detail.
5. Connect and plug in, see pictures below, the 3-wire RTD Temperature Probe connector into the bottom left connection point on the Control Box. Single-pin facing left side, press tab facing the back, and press connector all the way in until firmly engaged and an audible "click" is heard.
6. Connect and plug in, see pictures below, press tab facing the back, the 4-wire Motor Connector into the bottom center connection point on the Control Box. Press the connector all the way in until firmly engaged and an audible "click" is heard.
7. Connect Barrel Connector to bottom right side of Control Box. This is 110Volt Power Supply.
8. Open all inlet and outlet check-stops and ball valves to pressurize Proton valve.
9. Plug power supply into 110V receptacle. GFCI receptacles are recommended. Installer to follow local electrical codes.
10. Powering Valve Control Box will cause the valve motor to initiate a FULL VALVE SWEEP (End to End), indicating that the motor has traveled 900-1500 Steps. Please Record this initial Full Valve Sweep Value _____ Following the FULL SWEEP, the valve is ready for use and the LED Screen will display the following:

ALIGNED CORRECTLY



ALIGNED CORRECTLY

ALIGNED WRONG

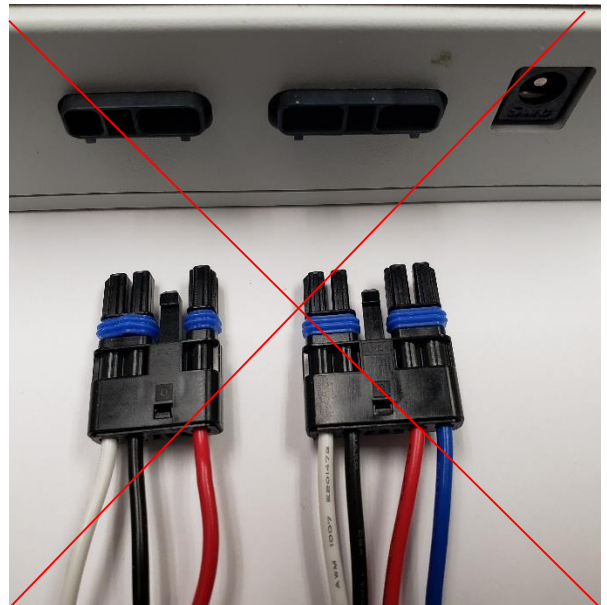

ALIGNED WRONG

User Screens

Home Screen: Current outlet temperature and Set point temperature



Home Screen: After initial “Full Sweep” the bottom line of the digital display indicates the measured sweep value of the valve, hot to cold. Please record this numerical value as you will need it for calibration Screen 2 below. If you “miss” the “full sweep” number simply unplug the unit and plug back in and the unit will do another sweep and give you the value. The digital display now indicates current measured temperature on the mixed outlet of the valve and shows set point temperature on the line below. **Note:** A large negative value displayed at the **Cur temp** line indicates the sensor is damaged or not properly wired to the main control board.

Temperature Adjustment: Temperature is easily adjusted by pressing the key code sequence ▲ ▼ ▲ ▼ ENTER key. At this point, the Setpoint will flash, and the ▲ and ▼ keys can now be used to adjust temperature up or down. When desired value is reached, pressing the ENTER key will store the new set point temperature and a message stating that the set point has been saved will be displayed. If no new temperature is saved, the screen display will revert back to the Home Screen after approximately 10 seconds and the set point will remain unchanged. Symbols + and – indicate whether the outlet temperature is being adjusted higher (+) or lower (-) by the controller.

Standard Menu: Options on Board/Equipped:

Pressing either the ▲ or ▼ keys will allow a user to scroll through other data points, features and options of the valve and will show the following screens and features in order.

Note: ▼ key was used for this manual’s sequence and should be considered forward direction in the menu. Pressing the ▲ key will reverse the order and can be considered reverse direction.

Menu Screen 1: Main Power Supply



Pressing ▼ 1 time displays **POWER: 12.82**

This indicates the input supply voltage to the main control board, Volts DC, and should always be at least 12 VDC

Menu Screen 2: Firmware Revision



Pressing ▼ 2 times displays **FW Rev: X.X.X.X**

This screen shows the current version of Firmware loaded into the Proton processor. It may be used for reference and troubleshooting.

From ANY screen, the user must enter the CALIBRATION Menu in order to record the initial numerical Full Valve Sweep value (recorded in Step 10 above) for comparison to future Valve Sweep Values for any maintenance warnings moving forward on this device. To Enter Calibration: Press the ▲ ▼ buttons simultaneously. The following screen should appear:

Calibration Screen 1: RTD Probe Calibration



This Calibration Screen is used in the event that the outlet valve temperature display differs significantly from a downstream temperature measurement value. It is a way to OFFSET the outlet temperature in order to agree with another temperature measurement value. Press **ENTER** to adjust Cal value, it will flash. Use ▲ ▼ buttons to adjust Cal value (+/-) in order to agree with other values. Press **ENTER** to save the Cal value. If Calibration is not needed, Press the ▼ arrow to advance to the next screen.

Calibration Screen 2: Full Valve Sweep Counts



The above Calibration Screen is used to enter the initial Full Valve Sweep Value obtained and recorded in Step #10 from initial power up. Press **ENTER** to input FVS value, it will flash. Use ▲ button to adjust FVS counts value and advance until it agrees with the Initial Sweep Value recorded in Step #10 above. Press **ENTER** to save the FVS counts value. To Exit Calibration: Press the ▲ ▼ buttons simultaneously. This will return you to the HOME Screen:

Home Screen: Current outlet temperature and Set point temperature



The user is returned to the 'Home Screen' which displays current temperature as measured on valve outlet and the set point temperature on the line below.

Note: A large negative value displayed at the **Cur temp** line indicates the sensor is damaged or not properly wired to the main control board.

Note: Pressing the ▲ key will reverse the order previously shown and allow the user to scroll through the above menu items in reverse order.

Proton Digitally Controlled Mixing Valve Error Codes

Error codes are displayed on the LCD screen. Errors must be manually cleared by pressing **ENTER** and the error condition has been corrected. There are 2 Error Codes on the Proton Digitally Controlled Mixing Valve. Error codes are listed below:

Error Code 1: **Check Probe (Temperature Probe)**



This Error indicates that the RTD Temperature Probe installed in the valve outlet is either disconnected from the Control Box or the wires are broken and it is in need of replacement. Please verify 3 wire connector on left side of control box is firmly engaged and verify that wires are continuous to the probe end. Replace if necessary. See Page 8 for details.

Error Code 2: **Valve Service Required**



This Error indicates that the Proton Valve has reached less than 90% of initial Sweep Value recorded in Step #10. This translates into lost motion on the shuttle and ultimately loss of ideal temperature control. The Mechanical Valve Components should be taken apart, cleaned of any and all debris or scale inside the valve body, inspected and serviced. Worn components must be replaced if necessary.

SENSOR TROUBLESHOOTING AND REPLACEMENT

When a sensor is disconnected or no longer in proper working condition, an error message is displayed on the controller **Err: Check Probe** See Error Code 1 above.

TURN OFF POWER TO THE PROTON CONTROL BOX BEFORE TROUBLESHOOTING OR REPLACING ANY WIRES AND SENSORS.

Determine if the sensor is truly broken and not a simple disconnection. Please verify the 3-wire RTD Temperature Probe connector is firmly plugged into its location on the bottom left of the Proton Control Box.

If the sensor is properly connected to the controller and the condition persists, then the sensor needs to be replaced. Contact Local Leonard Valve Representation for part number **803203**

1. Shut down hot, cold and outlet ball valves and depressurize the pipes. Remove the defective sensor from the piping and install new sensor in its place. For RTD probes new compression fittings are required. **Do not overtighten** compression nuts before re-pressurizing valve (**See Page 9**).
2. Open cold line and outlet ball valves to pressurize valve, once it is confirmed there are no leaks open the hot line as well. Introduce power to the Proton control box and confirm that the replacement sensor is providing proper feedback and data.

INSTALLING AND REPLACING TEMPERATURE PROBES

The RTD temperature probes used with Proton assemblies are simple to install. On the valve body the temperature probe is connected to the valve with a $\frac{1}{4}$ " MNPT x $\frac{1}{8}$ " compression fitting. Teflon tape and a small amount of thread sealant should be used on the NPT side of the fittings. The ferrule, installed with the cone facing down, then sits on the top of the compression inlet. The compression nut is then put over the ferrule and tightened slightly, just enough to hold the ferrule in place. The RTD temperature probe is then inserted through the entire fitting until the end of the probe reaches approximately the center of the desired measured water stream. Finally, the compression nut is tightened by hand to "hand-tight" plus $\frac{1}{8}$ to $\frac{1}{4}$ turn with an adjustable or open end wrench. **Use caution not to overtighten the fitting and only tighten until dripping stops.**

NOTE: if overtightened, leaks are probable and the entire RTD and compression fitting must be replaced!

Replacement part #803203



INSTALLATION OF COMPRESSION FITTING AND OUTLET RTD PROBE ON 2" NUCLEUS VALVE BODY

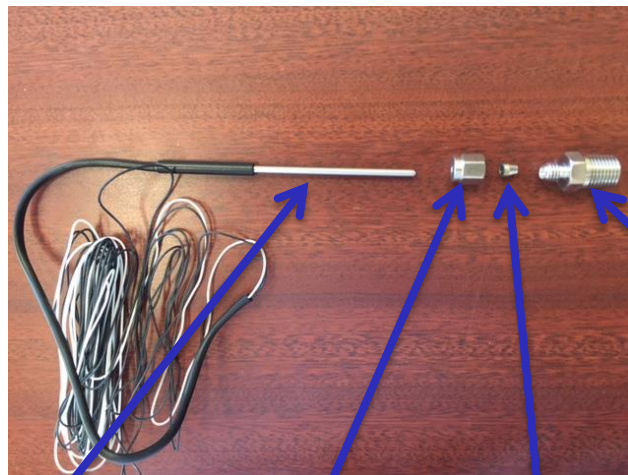

$\frac{1}{4}$ " NPT x Compression Fitting

RTD Probe with
10' Lead Wire

Compression Nut

Ferrule

REQUIRED PIPING METHOD W

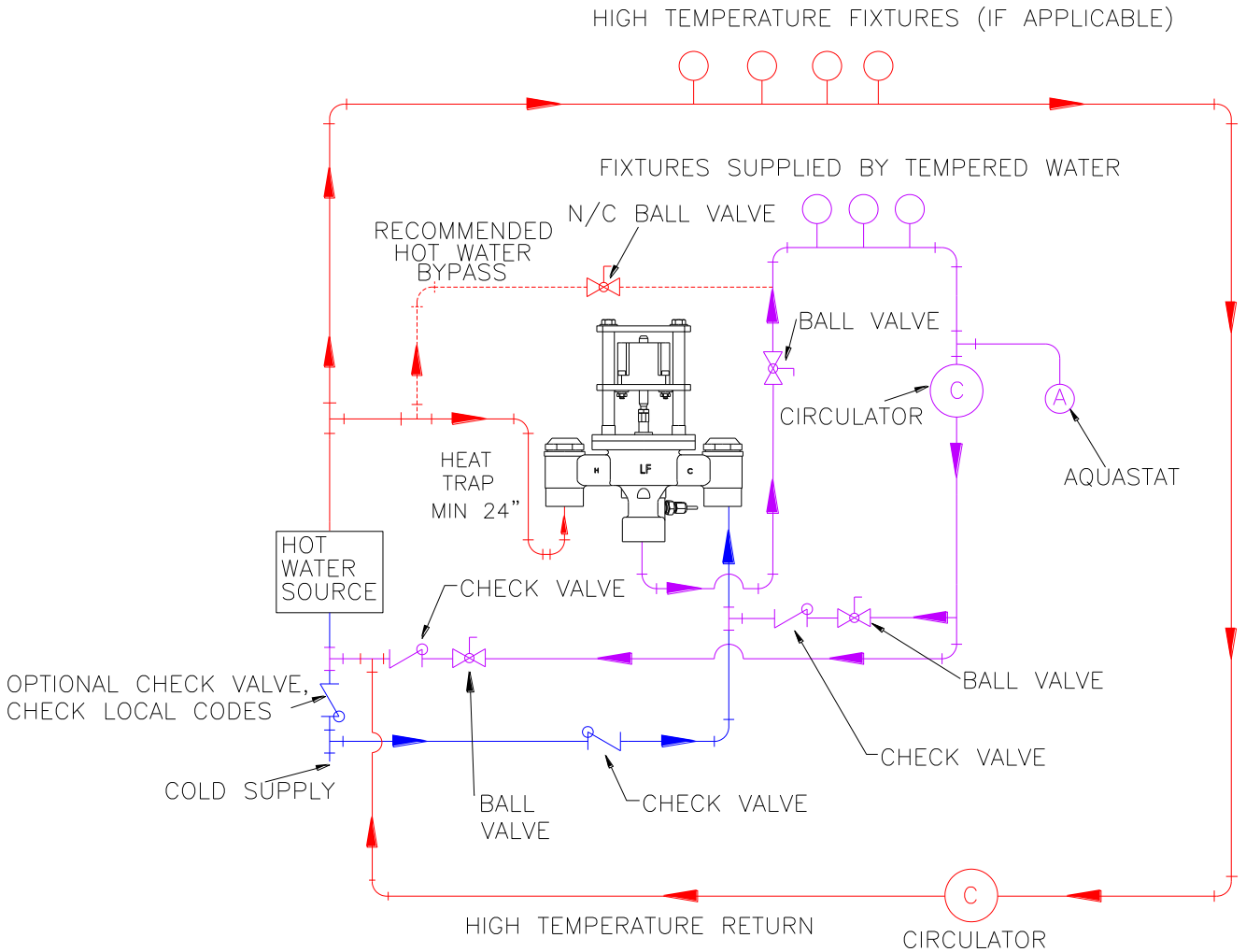

NOTE:
FOR MULTIPLE TEMPERED LOOPS, A BALANCING VALVE AND CHECK VALVE MUST BE INSTALLED ON EACH LOOP AFTER TEMPERED FIXTURES

Leonard Proton Digital Mixing Valves are simple in design and may be easily cleaned, adjusted and repaired. If the installation is accessible, servicing may be completed without disconnecting the valves.

NOTE: Leonard Proton Digital Mixing Valves must be regularly maintained to provide best performance. Frequency of cleaning depends on quality of local water conditions and usage. See Maintenance Guide and Record MGR-1000

PNV100	PNV125	KIT TYPE	INCLUDES
KIT 1/PNV1	KIT 1/PNV2	O-RING KIT	1 - 4
KIT R/PNV1	KIT R/PNV2	COMPLETE REPAIR	1 - 6
KIT 2/50	KIT 2/50	CHECK KIT	7 - 10

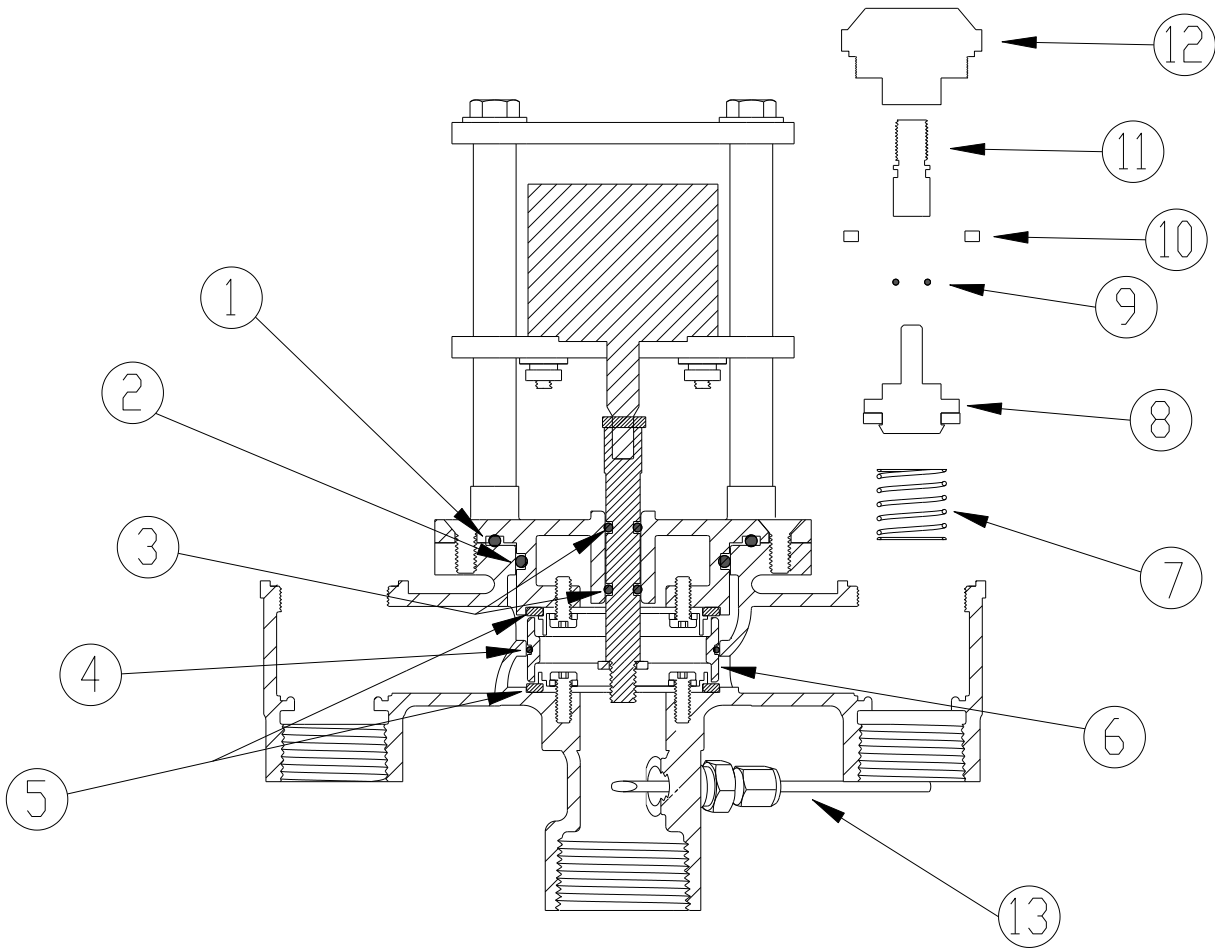

ITEM #	DESCRIPTION	QTY.	PNV100	PNV125
1	O-RING, COVER	1	KIT 1/PNV1, KIT R/PNV1	KIT 1/PNV2, KIT R/PNV2
2	O-RING, COVER	1	KIT 1/PNV1, KIT R/PNV1	KIT 1/PNV2, KIT R/PNV2
3	O-RING, STEM	2	KIT 1/PNV1, KIT R/PNV1	KIT 1/PNV2, KIT R/PNV2
4	O-RING, SHUTTLE	1	KIT 1/PNV1, KIT R/PNV1	KIT 1/PNV2, KIT R/PNV2
5	SEAT, HOT / COLD	2	KIT R/PNV1	KIT R/PNV2
6	SHUTTLE	1	KIT R/PNV1	KIT R/PNV2
7	SPRING	2	011, KIT 2/50	011, KIT 2/50
8	LOWER STEM W/PACKING	2	03, KIT 2/50	03, KIT 2/50
9	O-RING, UPPER STEM	2	MU-5A, KIT 2/50	MU-5A, KIT 2/50
10	PACKING, BONNET	2	05, KIT 2/50	05, KIT 2/50
11	UPPER STEM	2	MU-4A RF	MU-4A RF
12	BONNET	2	02 RF	02 RF
13	THERMOCOUPLE AND FITTING	1	803203	803203

PNV150 / PNV200	KIT TYPE	INCLUDES
KIT R/NV	COMPLETE REPAIR	1 - 8
KIT 1/NV	O-RING	1 - 5

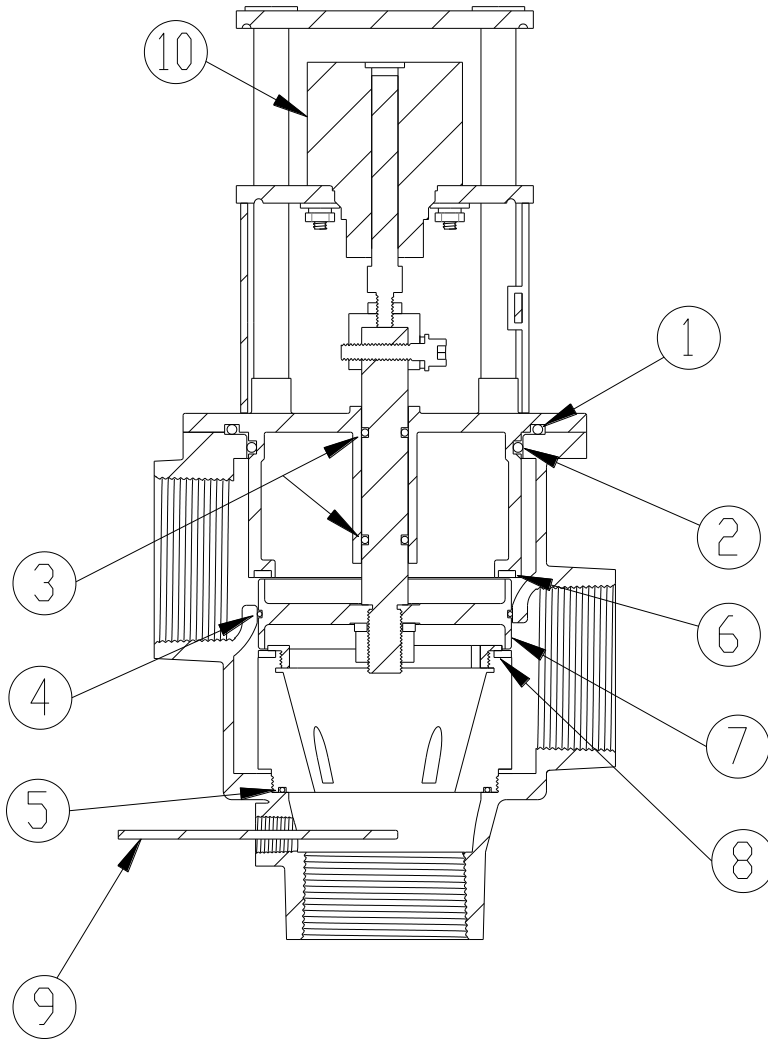

ITEM #	DESCRIPTION	QTY.	PNV150 / PNV200
1	O-RING, COVER	1	KIT 1/NV, KIT R/NV
2	O-RING, COVER	1	KIT 1/NV, KIT R/NV
3	O-RING, STEM	2	KIT 1/NV, KIT R/NV
4	O-RING, SHUTTLE	1	KIT 1/NV, KIT R/NV
5	O-RING, SLEEVE	1	KIT 1/NV, KIT R/NV
6	SEAT, HOT SIDE	1	KIT R/NV
7	SHUTTLE	1	KIT R/NV
8	SEAT, COLD SIDE	1	KIT R/NV
9	THERMOCOUPLE AND FITTING	1	803200
10	MOTOR	1	802500

PNV-150-LF, 1-1/4" CHECKS

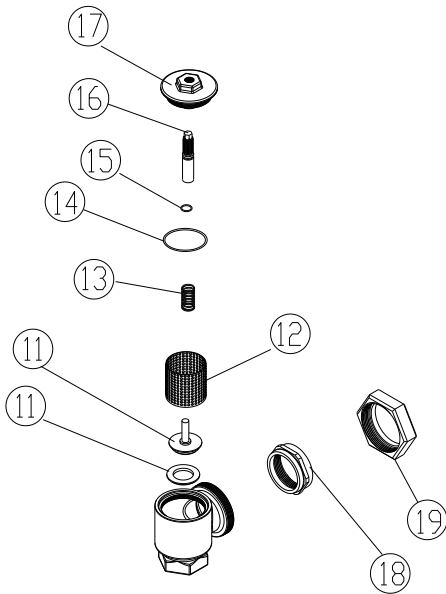

KIT	DESCRIPTION	INCLUDES
KIT 4/984	REBUILD KIT	11-15

ITEM #	DESCRIPTION	QTY.	PART # / KIT #
11	LOWER STEM & PACKING	2	KIT 4/984
12	SCREEN	2	KIT 4/984
13	SPRING,CHECK	2	KIT 4/984
14	O-RING, COVER	2	KIT 4/984
15	O'RING, UPPER STEM	2	KIT 4/984
16	STEM, UPPER CHECK	2	1761
17	CHECK BONNET	2	1786
18	SWIVEL	2	1705
19	SWIVEL NUT	2	4611

PNV-200-LF, 2" CHECKS

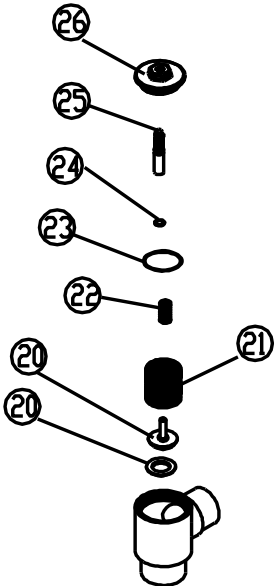

KIT	DESCRIPTION	INCLUDES
KIT 2/200/C	REBUILD KIT	20-24

ITEM #	DESCRIPTION	QTY.	PART # / KIT #
20	LOWER STEM & PACKING	2	KIT 2/200/C
21	SCREEN	2	KIT 2/200/C
22	SPRING,CHECK	2	KIT 2/200/C
23	O-RING, COVER	2	KIT 2/200/C
24	O'RING, UPPER STEM	2	KIT 2/200/C
25	STEM, UPPER CHECK	2	4727
26	CHECK BONNET	2	4723

REMEMBER! THIS IS A CONTROL DEVICE WHICH MUST BE CLEANED AND MAINTAINED ON A REGULAR BASIS (SEE MAINTENANCE GUIDE AND RECORD)

MODEL	IN	OUT	MINIMUM FLOW GPM	PRESSURE DROP										
				5	10	15	20	25	30	35	40	45	50	PSI
				L/MIN	0.3	0.7	1.0	1.4	1.7	2.1	2.4	2.8	3.1	3.4
PNV-100-LF	3/4" (19.1mm)	1" (25.4mm)	0.25*	17	25	28	32	36	39	43	45	48	51	GPM
			0.95*	64	95	106	121	136	148	163	170	182	193	L/MIN
PNV-125-LF	1" (25.4mm)	1 1/4" (31.7mm)	0.25*	40	56	66	77	86	95	104	109	114	120	GPM
			0.95*	151	212	250	291	326	360	394	413	432	454	L/MIN
PNV-150-LF	1-1/4" (31.7mm)	1-1/2" (38.1mm)	0.25*	50	72	86	100	115	122	136	140	158	165	GPM
			0.95*	189	273	326	379	435	462	515	530	598	625	L/MIN
PNV-200-LF	2" (50.8mm)	2" (50.8mm)	0.25*	80	115	130	147	165	173	189	198	215	226	GPM
			0.95*	303	435	492	556	625	655	715	750	814	856	L/MIN

*WHEN INSTALLED NEAR HOT WATER SOURCE AND WITH A PROPERLY SIZED, CONTINUOUSLY OPERATING RECIRCULATION PUMP

CAUTION! ALL THERMOSTATIC WATER MIXING VALVES AND SYSTEMS HAVE LIMITATIONS! THEY WILL NOT PROVIDE THE DESIRED PERFORMANCE OUTSIDE OF THEIR FLOW CAPACITY RANGE! CONSULT THE CAPACITY CHART BELOW AND OBSERVE MINIMUM FLOWS SHOWN.

LIMITED WARRANTY

Leonard Valve Company (hereinafter, "Leonard") warrants the original purchaser that products manufactured by Leonard will be free from defects in material or workmanship under normal conditions of use, when properly installed and maintained in accordance with Leonard's instructions, for a period of one year from the date of shipment. During this period, Leonard will at its option repair or replace any product, or part thereof, which shall be returned, freight prepaid, to the Leonard factory and determined by Leonard to be defective in materials or workmanship. Leonard provides no warranty, express or implied, which extends beyond the description contained herein. LEONARD SPECIFICALLY DISCLAIMS ANY AND ALL IMPLIED WARRANTIES OF MERCHANTABILITY OR OF FITNESS FOR A PARTICULAR PURPOSE. Nonetheless, some jurisdictions may not allow the disclaimer of certain implied warranties, in which case Leonard hereby limits such implied warranties to the duration of the limited warranty period contained herein. Some jurisdictions may not allow limitations on how long an implied warranty lasts, so the foregoing durational limitation may not apply to you. In no event will Leonard be liable for labor or incidental or consequential damages. Any alteration or improper installation or use of this product will void this limited warranty. If any provision of this limited warranty is prohibited by law in the applicable jurisdiction, such provision shall be null and void, but the remainder of this limited warranty shall continue in full force and effect.