



Mixing Safety & Performance for Over 100 Years



SELF BALANCING - SELF CLEANING



ASSE 1017 | NSF 372 COMPLIANT
Made in the USA with Domestic and Imported Parts

1360 Elmwood Ave., Cranston, RI 02910
TF: 800.222.1208 | P: 401.461.1200 | F: 401.941.5310
www.leonardvalve.com



HOT WATER SOLUTIONS START HERE

-  Self balancing
-  Daily self cleaning feature
-  +/- 2°F temperature accuracy
-  Standard integral check valves on all models
-  Flow rates ideal for small scale design projects
-  Self Diagnostic
-  Digital electronic control with 2 line LCD display
-  Programmable temperature setpoint
-  Simple setup/simple error coding
-  Upon power failure, holds last set temperature to avoid thermal shock

MANY MODELS AVAILABLE

PNV-200-LF
Base Valve Only

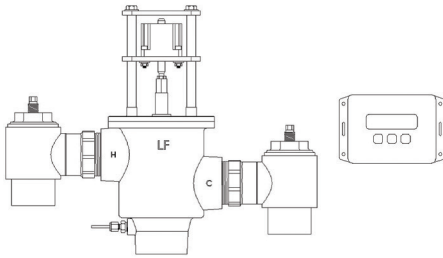

PNV-125-LF-R
Simple Recirculation

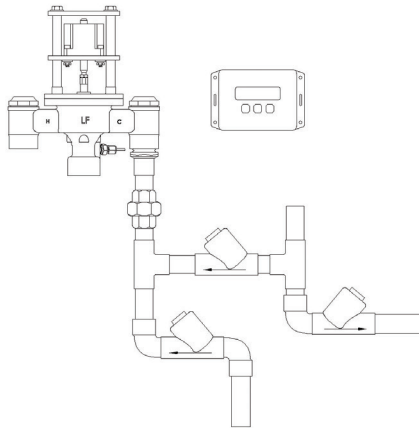

PNV-100-LF
Proton Megatron

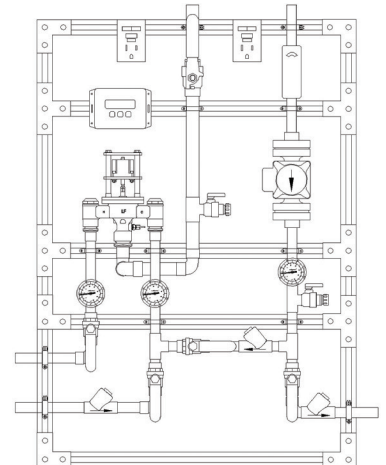

PNV-100-LF-R34
Enhanced Recirculation

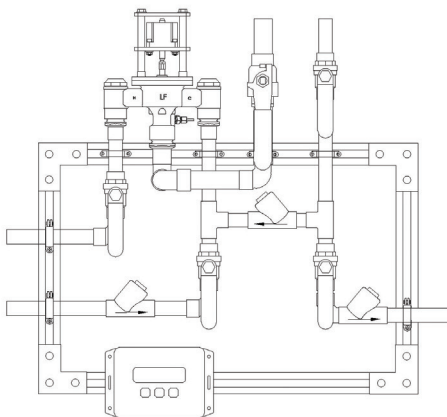

PNV-150-LF-2PS
High Capacity

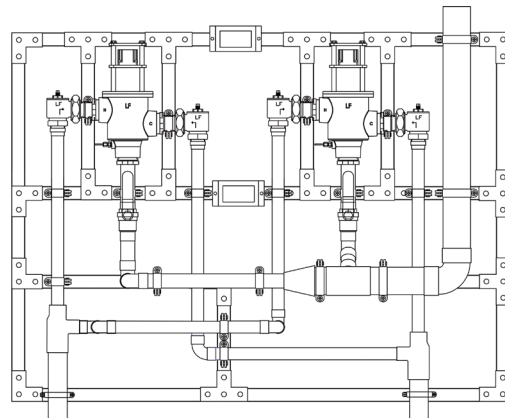

Temperature Control Valve

Flows & Capacities

MODEL	IN	OUT	MINIMUM FLOW GPM	PRESSURE DROP										
				5	10	15	20	25	30	35	40	45	50	PSI
				L/MIN	0.3	0.7	1.0	1.4	1.7	2.1	2.4	2.8	3.1	3.4
PNV-100-LF	3/4" (19.1mm)	1" (25.4mm)	0.25*	17	25	28	32	36	39	43	45	48	51	GPM
			0.95*	64	95	106	121	136	148	163	170	182	193	L/MIN
PNV-125-LF	1" (25.4mm)	1 1/4" (31.6mm)	0.25*	40	56	66	77	86	95	104	109	114	120	GPM
			0.95*	151	212	250	291	326	360	394	413	432	454	L/MIN
PNV-150-LF	1 1/4" (31.6mm)	1 1/2" (38.1mm)	0.25*	50	72	86	100	115	122	136	140	158	165	GPM
			0.95*	189	273	326	379	435	462	515	530	598	625	L/MIN
PNV-200-LF	2" (50.8mm)	2" (50.8mm)	0.25*	80	115	130	147	165	173	189	198	215	226	GPM
			0.95*	303	435	492	556	625	655	715	750	814	856	L/MIN

VALVE ASSEMBLY(S) ARE ASSE STANDARD 1017 LISTED
ALL VALVE ASSEMBLY(S) ARE 3RD PARTY CERTIFIED TO BE LEAD FREE
*WHEN INSTALLED NEAR HOT WATER SOURCE AND WITH A PROPERLY SIZED, CONTINUOUSLY OPERATING RECIRCULATION PUMP



MAXIMUM FLOW CAPACITY

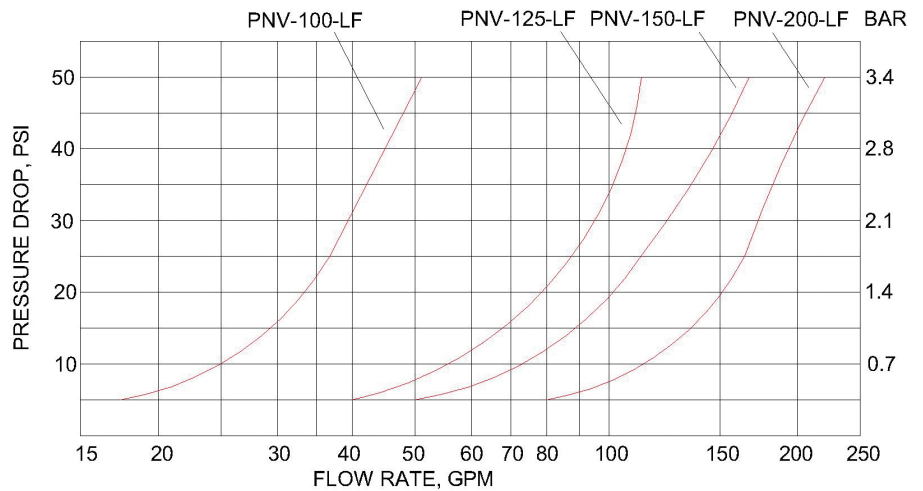

Available in:

- 3/4" inlet - 1" outlet valve assembly
- 1" inlet - 1 1/4" outlet valve assembly
- 1 1/4" inlet - 1 1/2" outlet valve assembly
- 2" inlet - 2" outlet valve assembly



Options:

- **BPS | Backup Power Supply Option**
 - Uninterruptable power supply with up to two hours of run time
- **LC | Less Circulator**
 - Only available for Megatron configurations
- **IOT/Internet of Things**
 - Modbus to WiFi gateway



LV-200 REV AUG 2020
©2020 LEONARD VALVE COMPANY
PRINTED IN THE U.S.A

1360 Elmwood Ave., Cranston, RI 02910
TF: 800.222.1208 | P: 401.461.1200 | F: 401.941.5310
www.leonardvalve.com