



Installation and Operation
Instructions for

FT SERIES

Floor Standing, Modulating
Gas, Condensing, Combination Boiler

Model FTCF199N
199,000 BTU/h



- Natural Gas (NG) - Factory Configuration
- Propane Gas (LP) - Field-Convertible

FOR YOUR SAFETY: This product must be installed and serviced by a professional service technician, qualified in hot water boiler and heater installation and maintenance. Improper installation and/or operation could create carbon monoxide gas in flue gases which could cause serious injury, property damage, or death. Improper installation and/or operation will void the warranty.

⚠ WARNING

If the information in this manual is not followed exactly, a fire or explosion may result causing property damage, personal injury or loss of life.

Do not store or use gasoline or other flammable vapors and liquids in the vicinity of this or any other appliance.

WHAT TO DO IF YOU SMELL GAS

- Do not try to light any appliance.
- Do not touch any electrical switch; do not use any phone in your building.
- Immediately call your gas supplier from a nearby phone. Follow the gas supplier's instructions.
- If you cannot reach your gas supplier, call the fire department.

Installation and service must be performed by a qualified installer, service agency, or gas supplier.

⚠ AVERTISSEMENT

Assurez-vous de bien suivre les instructions données dans cette notice pour réduire au minimum le risque d'incendie ou d'explosion ou pour éviter tout dommage matériel, toute blessure ou la mort.

Ne pas entreposer ni utiliser d'essence ou ni d'autres vapeurs ou liquides inflammables dans le à proximité de cet appareil ou de tout autre appareil.

QUE FAIRE SI VOUS SENTEZ UNE ODEUR DE GAZ:

- Ne pas tenter d'allumer d'appareils.
- Ne touchez à aucun interrupteur. Ne pas vous servir des téléphones dans le bâtiment où vous vous trouvez.
- Appelez immédiatement votre fournisseur de gaz depuis un voisin. Suivez les instructions du fournisseur.
- Si vous ne pouvez rejoindre le fournisseur de gaz, appelez le service des incendies.

L'installation et l'entretien doivent être assurés par un installateur ou un service d'entretien qualifié ou par le fournisseur de gaz.

TABLE OF CONTENTS

SECTION 1 Introduction		4.16 Plumbing Guidelines 43
1.1 About this Installation Manual.....	3	4.16.1 External Plumbing and Water Connection Guidelines.....
1.2 Included in the Box.....	4	43
SECTION 2 Product Characteristics		4.16.2 Applicable Backflow Preventer.....
2.1 Model Nomenclature (model number).....	4	43
2.2 Specifications.....	5	4.16.3 Diaphragm type Expansion tank.....
2.3 Dimensions.....	6	43
2.4 Names of Components.....	7	4.16.4 DHW Piping including DHW Recirc Piping.....
2.5 Product Flow Paths and Characteristics.....	8	44
2.5.1 Central Heating flow..	8	4.16.5 Zoning with zone valves.....
2.5.2 Domestic Hot Water flow.	8	46
SECTION 3 Safety Regulations		4.16.6 Zoning with a Single Pump.....
3.1 Safety Symbols.....	9	48
3.2 Safety Precautions and Proper Use.....	10	4.16.7 Zoning with Multiple Pumps.....
SECTION 4 Installation		50
4.1 Location and Clearances.....	12	4.17 Pressure Relief Valve.....
4.2 Flooring & Leveling.....	13	52
4.3 Combustion Air 14		4.18 Disposal of Condensate 53
4.3.1 Combustion Air from Room.....	14	4.19 DHW Flow Restrictors.....
4.3.2 Ducted Combustion Air.....	14	54
4.4 Venting (Exhaust)..... 16		4.20 Electrical Wiring Connections 55
4.5 General Location Guideline.....	17	4.21 DIP Switches.....
4.6 Locations for Vent Pipe Terminator.....	18	56
4.6.1 Venting Requirements in the Commonwealth of Massachusetts.....	19	4.22 Control Board, Electrical Diagram.....
4.7 Common Vent Test.....	20	57
4.8 Air Supply and Vent Connections.....	21	4.23 Ladder Diagram.....
4.8.1 Vent / Air Pipe Lengths.....	21	58
4.8.2 Direct Venting.....	21	4.24 Electrical Connections (table).....
4.8.3 Indoor Combustion Air.....	22	59
4.9 Vent / Air Pipe Termination.....	22	SECTION 5 Control Display and Operation
4.10.1 Concentric Venting Systems.....	25	5.1 Control Dial and Buttons.....
4.10.2 Installation of a new Concentric stainless steel Venting System.....	26	61
4.10.3 Stainless steel Concentric Venting using an existing stainless steel Venting.....	27	5.2 LCD Overview.....
4.10.4 Installation of Duravent PPS Concentric System.....	28	62
4.10.5 Duravent PPS Concentric System to an existing Heat-Fab SC Venting System.....	29	5.3 Operating Mode.....
4.10.6 Flexible Chimney Liner Venting.....	32	63
4.11 Gas Supply and Piping..... 33		5.4 Status Display Mode.....
4.12 Gas Supply Pressure.....	36	64
4.13 Adjusting Combustion.....	37	5.5 DHW Set Point Change Mode.....
4.14 High Altitude Installations.....	38	65
4.15 Natural Gas to Propane Conversion.....	39	5.6 CH Set Point Change Mode.....
		66
		5.7 Storage Mode.....
		66
		5.8 Installer Parameters.....
		67
		5.9 Outdoor Reset Adjustment.....
		70
		5.10 External Set Point Temperature Control.....
		70
		5.11 Error Mode.....
		71
		SECTION 6 Error Codes
		6.1 Error Code Tables.....
		72
		6.2 Fault Tree Analysis.....
		75
		SECTION 7 Trouble Shooting
		7.1 Diagnostics.....
		77
		7.2 Suggested Corrective Actions.....
		78
		SECTION 8 Maintenance..... 81
		8.1 Annual startup & general maintenance.....
		81
		8.2 Flushing the Combination Boiler.....
		83
		8.3 Draining and Cleaning.....
		84
		8.4 Freeze Protection.....
		84
		SECTION 9 Installation Check
		9.1 Quick View.....
		85
		9.2 Final Check Lists.....
		86
		SECTION 10 Parts List and Illustrations
		10.1 FT 199.....
		87

SECTION 1 Introduction

1.1 About this Installation Manual

For details on Plumbing for Domestic Hot Water, (Pages 43-45)

For details on Gas Connections/ Combustion Setup (Pages 32-42)

For details on Combustion Air and Venting, (Pages 14-32)

For details on Plumbing for Central Heat, (Pages 43-52)

All installations must be made in accordance with
 1) American National Standard Z223.1/ NFPA54-Latest Edition "National Fuel Gas Code" or
 2) CSA B149.1 "Natural Gas and Propane Installation Code" and with the requirement of the local utility or other authorities having jurisdiction. Such applicable requirements take precedence over the general instructions contained herein.

All electrical wiring is to be done in accordance with the local codes, or in the absence of local codes, with: 1) The National Electrical Code ANSI/NFPA No. 70-latest Edition, or 2) CSA STD. C22.1 "Canadian Electrical Code - Part 1". This appliance must be electrically grounded in accordance with these codes.

This manual provides the information necessary for the installation, operation, and maintenance of the FT Series Floor Standing, Combination Boiler.

All application and installation procedures must be read and reviewed completely before proceeding with the installation. Consult the factory, or your local factory representative, with any problems or questions regarding this equipment. Experience has shown that most operating problems are caused by improper installation.

For details on Electrical Connections, (Pages 45-51 and 52-56)





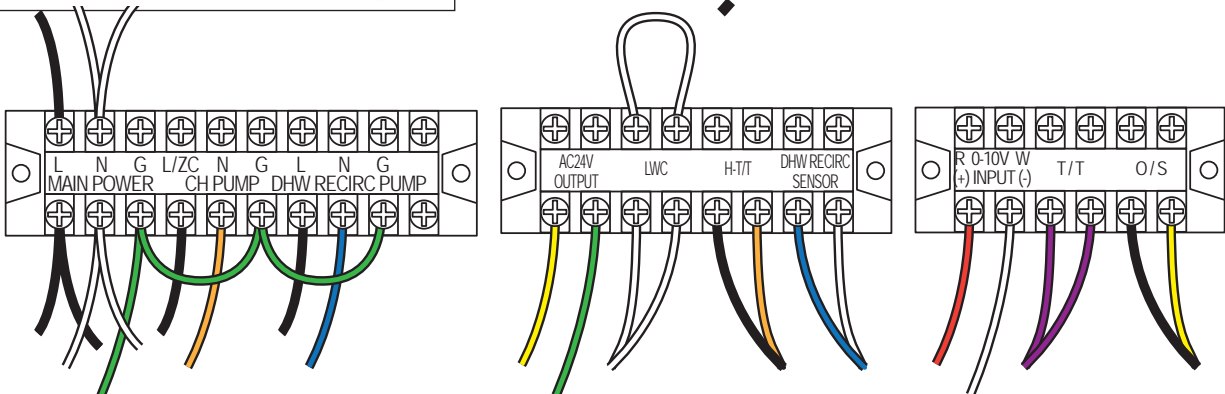



The H-T/T terminals can only be used for a constant high temperature heating zone or to place the boiler in temporary high temperature "manual" operation.

For details on Plumbing for Condensate, (Page 53)



***Note:** Do NOT connect 24 V to the T/T or H-T/T terminals. Only connect a dry contact closure to these terminals.

1.2 Included in the Box

Item	Description	Qty	Item	Description	Qty
Floor Standing Combination Boiler FTCF 199, Adjustable boiler leveling feet (Installed)		1	Installation Instructions and User's Manual		1
Silicone tubing for air relief on condensate trap condensate hose		1	3" Mesh Screens		1
O-Ring and Gasket Kit		1	Outdoor sensor		1
30 psi relief valve, air vent and brass adaptor with 3/4" plug. Part of (accessory box)		1	4.5 GPM Flow Restrictor (dark blue)	*  (model FT140CF only)	1
			Propane Conversion Orifice	** 	

Accessory Box: Boiler 3/4" relief valve (30 psi), combination "brass adaptor" fitting, 3/4" plug for "brass adaptor" fitting, manual air vent, 3/4" female cap for recirc connection, Taco 5003 mixing valve, 2 3" mesh screens, outdoor sensor, O-ring and gasket kit, boiler feet

**A 7.0 GPM restrictor (white / grey) is factory installed in the FTCF199.

Auto Fill Valve and Backflow Preventer Valves are NOT included (Field Supplied).

SECTION 2 Product Characteristics

2.1 Model Nomenclature (model number)

The Model Nomenclature is shown on your Rating Plate and consists of a series of letters and numbers (**Nomenclature**) that further identifies the characteristics of your FT Series Combination Boiler.

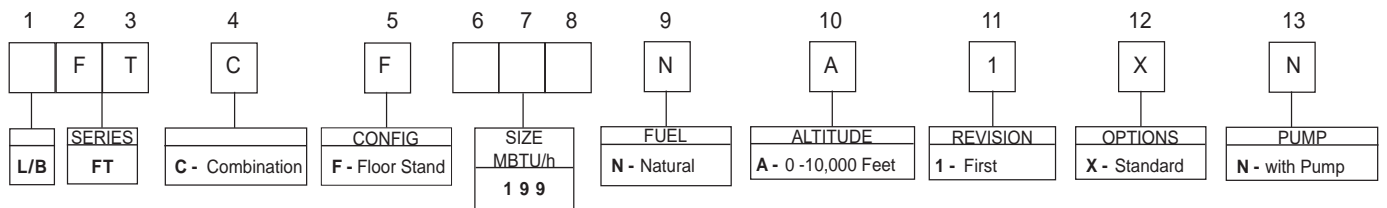
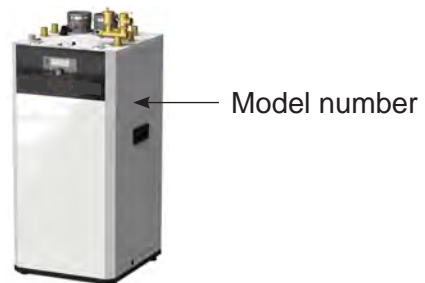

2.2 Specifications, 199

Model Name		FTCF199N			
Gas Input Rate	MAX	199,000 Btu/h			
	MIN	19,900 Btu/h			
Hot Water Capacity	35°F Rise	9.88 GPM			
	45°F Rise	7.7 GPM			
	77°F Rise	4.8 GPM			
Installation		Indoor / Floor stand type			
Flue System		Sealed Combustion Direct / Single Vent / Concentric Vent			
Vent Run		2"(50ft), 3"(100ft) Schedule 40 CPVC, PP, PVC, Stainless Steel, PP Flex			
Orifice Size	NG	0.326" (8.3 mm)			
	LP	0.250" (6.35 mm)			
Gas Supply Pressure	NG	3.5" WC to 10.5" WC			
	LP	8.0" WC to 13" WC			
Manifold	Gas type	NG		LP	
	Vent size	2" VENT	3" VENT	2" VENT	3" VENT
	Max Fire	-0.129"WC	-0.314"WC	-0.169"WC	-0.173"WC
	Min Fire	-0.015"WC	-0.015"WC	-0.015"WC	-0.015"WC
Power Supply	Main Supply	120V 60Hz / 4A			
	Maximum Power Consumption	160W			
Ignition System		Direct Electronic Ignition / Automatic Flame Sensing			
Burner System		Single Orifice Premixed Fuel Modulation			
Gas Valve System		Combination modulating (Current proportional)			
Minimum Flow Rate		0.5 GPM			
Dimensions		W 17-7/8" - H 38-1/4" - D 19-5/8"			
Shipping Weight		130 lbs (59 kg)			
Sub Heat Exchanger Water Capacity(DHW)		Under 1 Gallon			
Main Controller / Control Panel		NGTX-910CP / P-920C			
Domestic Hot Water Pressure, DHW		Min 15 ~ Max 150 PSI			
Central Heat Water Pressure, CH		Min 15 ~ Max 30 PSI			
Connection Sizes	Cold Water Inlet / Hot Water Outlet / DHW Recirc	3/4" NPT			
	Space Heating Supply / Return	1-1/2" NPT			
	Gas Inlet	3/4" NPT			
Materials	Casing	Cold Rolled Carbon Steel			
	Heat Exchanger	Primary Heat Exchanger : Stainless Steel Sub Heat Exchanger : Stainless Steel			
Safety Devices		Optical Flame Sensor, Overheat Cut Off Device, Gas Valve Operation Detector, Exhaust Temperature High Limit Switch, Water Temperature High Limit Switch, Low Water Cut Off, Air Pressure Sensor			

2.3 Dimensions

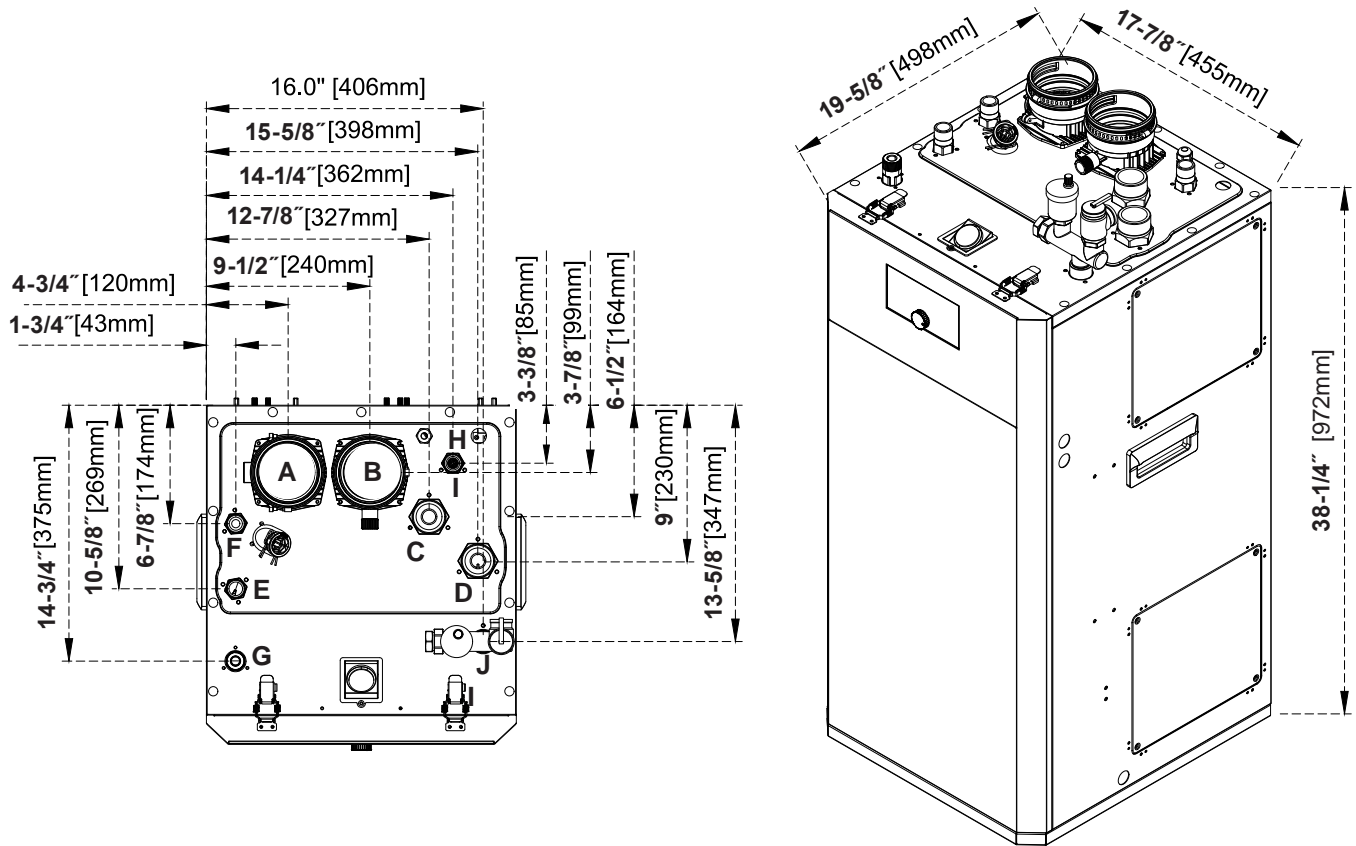

	Description	Diameter
A	Air Intake Collar	3"
B	Vent Pipe Collar	3"
C	Boiler Supply	1-1/2" NPT
D	Boiler Return	1-1/2" NPT
E	DHW Outlet	3/4" NPT
F	DHW Inlet	3/4" NPT
G	Gas Inlet	3/4" NPT
H	Condensate Line	1/2" (no NPT)
I	DHW Recirculation	3/4" NPT
J	Pressure Relief Valve & Air Vent	1" NPT

2.4 Names of Components

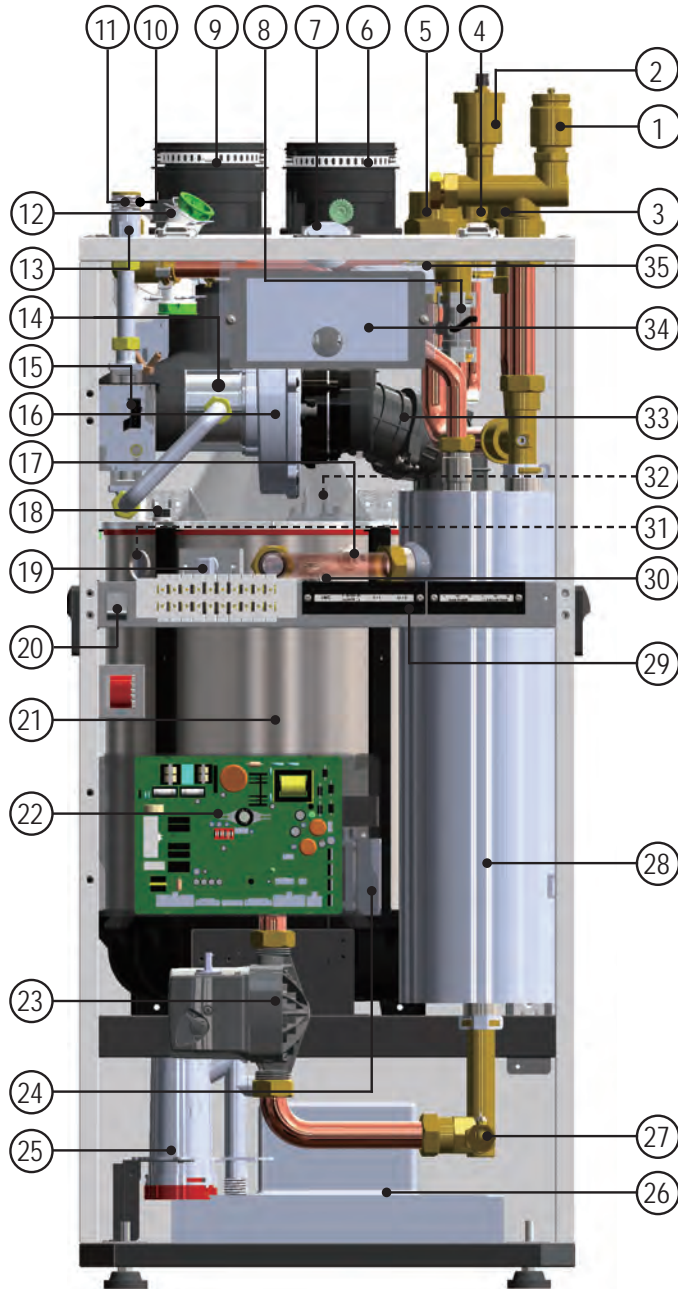

#	Name of Component
1	Pressure Relief Valve
2	Air Vent (air eliminator)
3	Boiler Return Connection
4	DHW Recirculation Connection
5	Boiler Supply Connection
6	Vent Pipe Collar
7	Boiler Pressure Gauge
8	Cold Water Flow Sensor
9	Air Intake Collar
10	DHW Inlet Connection
11	DHW Outlet Connection
12	DHW Filter and Flow Restrictor
13	Gas Inlet Adapter
14	Air/ Gas Venturi
15	Gas Valve
16	BLDC Fan (Blower)
17	Low Water Cut Off
18	Burner High Limit Switch
19	Flame Detecting Sensor
20	Manual Power Switch (ON / OFF)
21	Heat Exchanger
22	Main PCB
23	Boiler Pump
24	Blocked Condensate Switch
25	Condensate Trap
26	Condensate neutralizer and Drain pump (optional equipment)
27	Drain Valve
28	Low Loss Header and DHW Coil
29	Terminal Block
30	Overheat Temperature Sensor
31	Sight Glass
32	Igniter
33	Exhaust Pipe
34	Control Panel and Display
35	Air Pressure Sensor

2.5 Names of Components

2.5.1 Central Heating flow. Combination Boiler Heating Mode.

Water in the heating system flows through the low loss header (LLH); boiler pump heats water in the boiler and is circulated through LLH. System pump or individual zone pumps are required to pull heated water from CH supply connection and return water to CH return connection.

2.5.2 Domestic Hot Water flow. Combination Boiler Domestic Hot Water Mode.

Cold DHW flows into the coil and is heated by boiler pump as it circulates water between boiler and LLH. DHW priority is achieved through wiring heating zones via the CH pump output terminals. See section 4.19 for wiring.

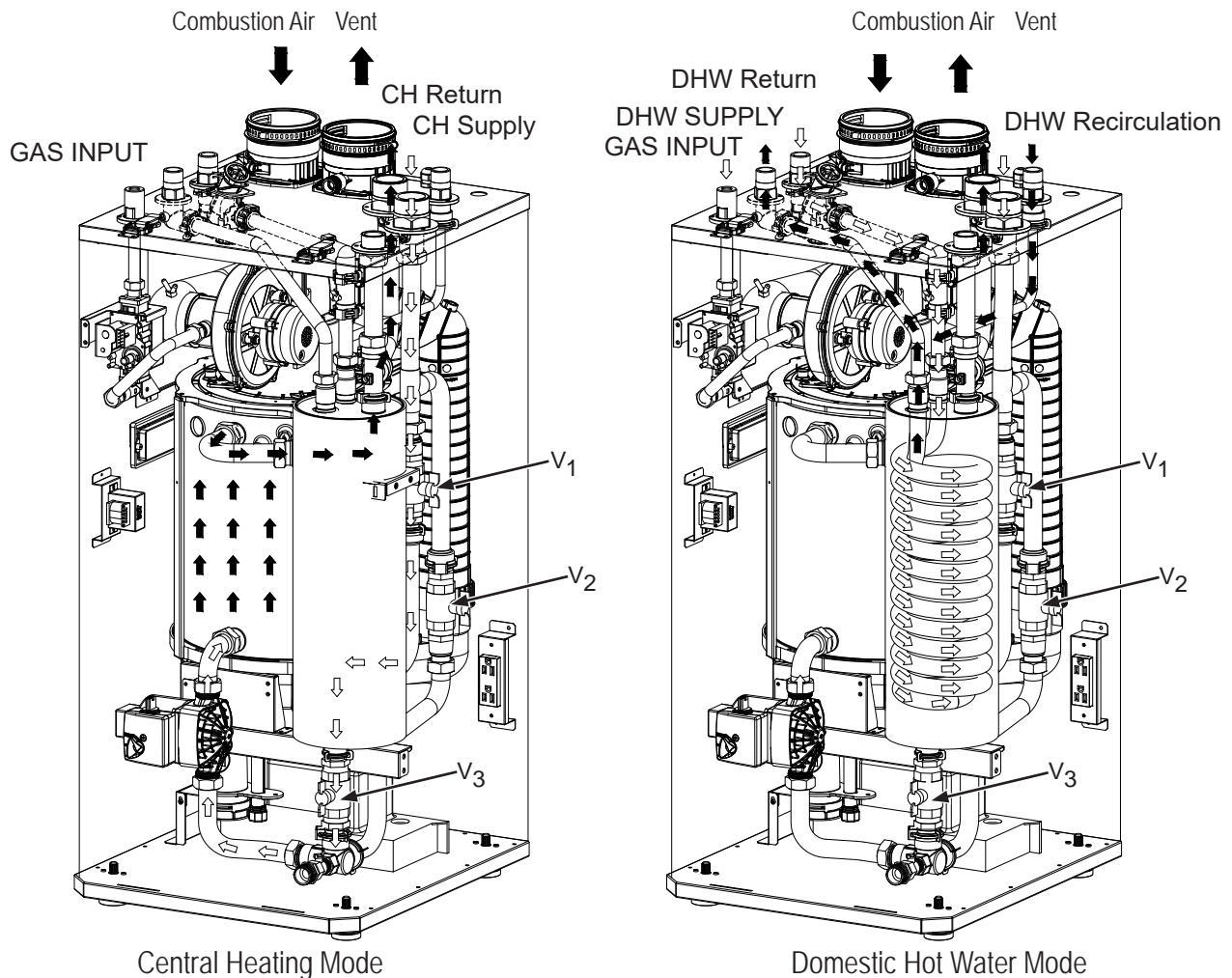

Factory default valve position: V1 and V3 open, V2 closed.

Air purge instructions:

1. Remove both access panels on the right-hand side to gain access to V1 and V2.
2. Close supply and return shut-off valves, isolate all zones and open fast fill valve on boiler feed as per IOM piping diagrams, pages 44-50.
3. Purge air and fill one zone at a time, starting with the furthest zone and open purge station above the return shut-off valve until all air has been released.
4. Continue to purge and fill zones until all zones are completely filled. Close return purge station.
5. Position valves as follows: V1 open, V2 closed, V3 closed. (handle horizontal- closed, vertical- open)
6. Open return shutoff to allow water to flow into low loss header/DHW tank, while purging air on boiler supply.
7. Close V1 and open V2. Purge air from boiler until completed.
8. Close V2, open V1 and V3. Perform final air purge and close supply purge station.

SECTION 3 Safety Regulations

3.1 Safety Symbols

WARNING

To avoid product damage, personal injury, or even possible death, carefully read, understand, and follow all the instructions in the Installation and Operation manual before installation, operation and service the Boiler.

Manufacturer cannot anticipate every circumstance that might involve a potential hazard. Therefore, all possible incidents are not included in our warnings. Proper installation, operation, and service are your responsibility. You must make sure that the operation and settings of the Boiler are safe for you and for others.

This manual provides Safety Symbols. When the user fails to adhere to the following requirement, it may cause death, serious injury, and substantial property damage.

For safety symbols, 'DANGER', 'WARNING', 'CAUTION' are indicated and the definitions for these terms are as follow:

DANGER

Indicates an imminently hazardous situation which, if not avoided, will result in death or serious injury. This signal word is limited to the most extreme situations.

WARNING

Indicates a potentially hazardous situation which, if not avoided, could result in death or serious injury.

CAUTION

Indicates a potentially hazardous situation which, if not avoided, may result in minor or moderate injury. It is also used to alert against unsafe practices and hazards involving only property damage.

WARNING

Cancer and Reproductive Harm.
www.P65WARNINGS.CA.GOV.

as required by the state of California Proposition 65.

WARNING

FOR YOUR SAFETY READ BEFORE OPERATING

If you do not follow these instructions exactly, a fire or explosion could result causing property damage, personal injury or loss of life.

- A. This appliance does not have a pilot. It is equipped with an ignition device which automatically lights the burner. Do not try to light the burner by hand.
- B. BEFORE OPERATING smell all around the appliance area for gas. Be sure to smell next to the floor because some gas is heavier than air and will settle on the floor.

WHAT TO DO IF YOU SMELL GAS

- Do not try to light any appliance.
 - Do not touch any electric switch; do not use any phone in your building.
 - Immediately call your gas supplier from a neighbor's phone. Follow the gas supplier's instructions.
 - If you cannot reach your gas supplier, call the fire department.
- C. Use only your hand to push in or turn the gas control knob. Never use tools. If the knob will not push in or turn by hand, don't try to repair it, call a qualified service technician. Force or attempted repair may result in a fire or explosion.
 - D. Do not use this appliance if any part has been under water. Immediately call a qualified service technician to inspect the appliance and to replace any part of the control system and any gas control which has been under water.

This appliance must be installed in accordance with local codes if any; if not, follow ANSI Z224.1/NFPA 54 or CAN/CSA B149.1, Natural Gas and Propane Installation Code, as applicable.

- This appliance is certified for use at altitudes up to 10,000 feet (3,044 m) in accordance to the latest CSA/CGA 2.17-M91 Gas-Fired Appliances for Use at High Altitudes.

3.2 Safety Precautions and Proper Use

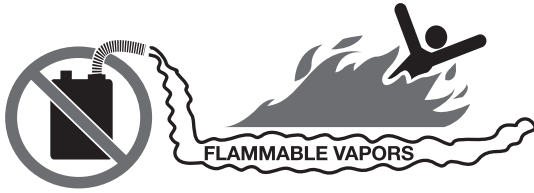

⚠ DANGER

- Vapors from flammable liquids will explode and catch on fire. These will cause death or severe burns.

Do not use or store flammable products such as gasoline, solvents or adhesives in the same room or area near the appliance.

Keep flammable products

- Far away from boiler
- In approved containers
- Tightly closed
- Out of children's reach

Vapors

- Cannot be seen
- are heavier than air
- spread on the floor
- Can spread from other rooms to the main burner by air currents

Do not install the appliance where flammable products will be stored.

Read and follow boiler warnings and instructions thoroughly. If owner's manual is missing, contact the retailer or manufacturer.

- This combination boiler must be installed by a qualified plumber, a licensed gas fitter, and/or a professional service technician. Improper installation and/or operation will cause a potentially hazardous situation, such as serious injury or death. Also, it will void the warranty.
 - The National Fuel Gas Code NFPA 54 / ANSI Z224.1
 - National Electric Code ANSI/NEPA 70
 - All applicable local, state, national and provincial codes, regulations and laws.
- Proper care is your responsibility. Carefully read and understand the Operating Information in this manual before operating the Boiler.
- Be aware of the location of the gas shut-off valve and operation method. Close the gas shut-off valve immediately if the appliance is subjected to fire, overheating, flood, physical damage, or any other

damaging condition that might affect the operation of the unit. Boiler must be checked by a qualified technician before resuming operation.

- DO NOT use this Boiler if any part has been under water. Immediately call a qualified technician for inspecting the Boiler and replacing any part of the control system and gas control which have been under water.
- Do not power up the unit until the gas and water supply valves are fully opened. Make sure that the fresh air intake port and exhaust gas port are opened and functional.
- DO NOT attempt to install, repair, or service this Boiler by yourself. Do not change any part of the Boiler. Contact a qualified technician if the Boiler needs repair or maintenance. Ask your gas supplier for a list of qualified service providers.
- DO NOT use spray paint, hair spray, or any other flammable spray near Boiler or near the exterior fresh air inlet port. DO NOT place any items in or around the exterior exhaust gas outlet port and/or fresh air inlet port. These could restrict or block the flow in or out of the vent system.
- "Caution: While repairing control, all wires are labeled. You must connect the wires in accordance with the instruction. Wiring errors can cause improper and dangerous operation.
- "Verify proper operation after servicing operation"
- This consists of the gas ignition system components which are protected from water (dripping, spraying, rain, etc.) during operation and service (circulator replacement, condensate trap, control replacement, etc.).
- After installing the heater, safety devices must be tested.
- This boiler is equipped with a blocked vent shutoff system. If the error code '44' occurs, follow the instructions below.
 - First, turn off the manual gas valve.
 - Make sure that there is no foreign object in the vent passage or rodent screen.
 - If you do not find any problem, do the following.
 - Turn off the error state by pressing the power button of control panel.
 - If the error occurs repeatedly, call your service technician or gas supplier.

Before Operation

1. Check the Gas Type (NG/LP) when using or moving the unit for the first time. Check if gas type matches with the gas type of the Boiler. Check whether the gas type which is supplied is NG (Natural Gas) or LP (Propane) and also check the Boiler gas type. The gas type is indicated on the rating plate on side of the Boiler.
2. Check the Power (120V 60Hz). Check that the appliance is connected properly.
3. Check the Cold Water Inlet valve. Please keep the appliance water inlet valve open at all times. The appliance will not ignite when insufficient water or no water is in the heating pipes. (valve: always open position)
4. Check the manual gas shut-off valve on top of the FT boiler gas connection. Make sure this manual gas shut-off valve is opened for operation.
5. Check the area around the appliance and remove any combustible or flammable materials. Remove laundry or any other items that are on or near the boiler or vent pipe.

When in Operation



1. Caution for gas leak
Frequently check for a gas leak at the gas connection portion with soapy water.

Steps to take if you have a gas leak.

1. Shut down the boiler as soon as gas fumes are detected.
2. Close the manual gas shut-off valve.
3. Open windows for ventilation.
4. Do not create any sparks! Leave the property immediately and call your local utility or qualified service technician for immediate repair.

WARNING

Do not use the appliance for any other purpose than for heating and hot water.
Do not store combustibles or flammable material such as gasoline near the appliance.
Do not store other items on or near this boiler.
Do not store combustible (flammable) materials such as papers.
Do not hang clothes on the vent pipe. This may start a fire.

2. Caution for Ventilation

Make sure that there is sufficient inflow and outflow of air ventilation while using the unit.

If the ventilation is improper, combustion quality may deteriorate inside the appliance and cause shortened life of the appliance.

3. Burn Warning

Be careful not to burn yourself on the flue or pipes. They become extremely hot during operation.

CAUTION

Scalding Risk: Manufacturer requires the use of the provided anti-scald mixing valve at domestic hot water outlet (boiler location) to reduce potential for scalding. See drawing in section 4.15.4 for proper installation. Check with local codes.

Carbon monoxide poisoning

If vent pipe fumes enter the room, it could cause poisoning by carbon monoxide gas. Check that the vent pipes are properly connected. Open windows for ventilation. Call a qualified service technician for immediate repair.

Gas leakage test.

Gas supply line must be inspected regularly.

Do not shut off the Boiler.

When you leave home for a long time, do not shut off Boiler. The Boiler has a freeze protection function.

Do not wipe the appliance or control panel with wet cloth. Electric shock may occur, or internal parts may fail due to the exposure to moisture.

Do not disassemble the Boiler.

If repair is required, call your local qualified technician.

CAUTION

After repair of gas pipeline or gas regulator replacement, call a qualified contractor for inspection before starting it up.

SECTION 4 Installation

4.1 Location and Clearances

The FT floor boiler must be installed on a level surface of sufficient strength and follow the clearances listed in Table 1. Leveling feet are provided to ensure a plumb installation.

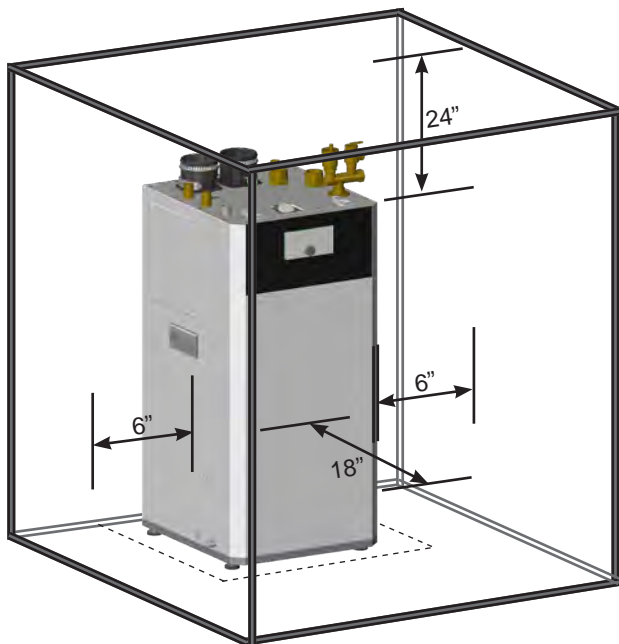

Appliance Surface	Clearance from Combustibles and Non-combustible Surfaces
Back	1 in (2.5 cm)
Left Side	1 in (2.5 cm)
Right Side	1 in (2.5 cm)
Front	1 in (2.5 cm)
Top (Alcove Install)	9 in (22.86 cm)
Top (Closet Install)*	22 in (56 cm)
Vent : Concentric, Direct	0 in (0 cm)
Vent : Category IV	3 in (76 cm)
Suggested Serviceability Clearances	
Front	18 in (46 cm)
Left Side	6 in (15 cm)
Right Side	6 in (15 cm)
Top	24 in (61 cm)

Table 1. Minimum Clearances to Combustibles and for Service.

⚠ WARNING

- Installations must comply with
 - All the local, state, provincial, and national codes, laws, regulations and ordinances.
 - National Fuel Gas Code, ANSI Z223.1 – The latest version.
 - National Electrical Code.
 - A National Standard of Canada CAN/CSA-B149.1
- Check before placing the Combination boiler
 - Always check the connected components which are near to the boiler. The components are below.
- Water piping position / Venting adapter / Gas supply piping / Electrical power / Condensate drain hose.
 - Inspect area around Combination boiler. Remove any combustible materials, gasoline and other flammable liquids. Failure to keep Combination boiler area clear and free of combustible materials, gasoline and other flammable liquids and vapors can result in severe personal injury, death or substantial property damage.
 - The Combination boiler which has gas control system components must be protected from any possible danger during operation and service.
 - If new Combination boiler replaces an existing appliance, check and correct system problems, for example:
 - Do not install if: System leaks causing oxygen corrosion or heat exchanger cracks from hard water deposits.
- Provide clearances
 - If the boiler was installed in a narrow space or corner, please ensure that there is sufficient space for service and maintenance access. For regular maintenance, gas and water lines must be accessible.
- This boiler must be installed upright in the vertical position as described in this manual.

⚠ WARNING

- CLEARANCES FOR SERVICE ACCESS
 - If you do not provide the minimum clearances shown, it might not be possible to service the boiler without removing it from the space.
 - Space must be provided with combustion / ventilation air openings correctly sized for all other appliances located in the same space as the boiler. The boiler cover must be securely fastened to prevent it from drawing air from the boiler room. This is particularly important if the boiler is in a room with other appliances. Failure to comply with the above warnings could result in substantial property damage, severe personal injury, or death.

4.2 Flooring & Leveling

⚠ WARNING

Make sure that the floor and structure of the installation location are sufficient to support the full installed weight of the boiler, including water content of the heat exchanger and related piping. Failure to ensure the floor and structure of the installation location are structurally sound before installation of the boiler can result in structural failure, substantial property damage, severe personal injury, or death.

This boiler is approved for installation on combustible flooring, but must never be installed on carpeting. Installing this boiler on carpeting could result in fire, property damage, severe personal injury, or death.

⚠ CAUTION

In order for the condensate to properly flow out of the collection system, the area where you locate the boiler must be level. Location must also fully support the weight of the filled boiler.

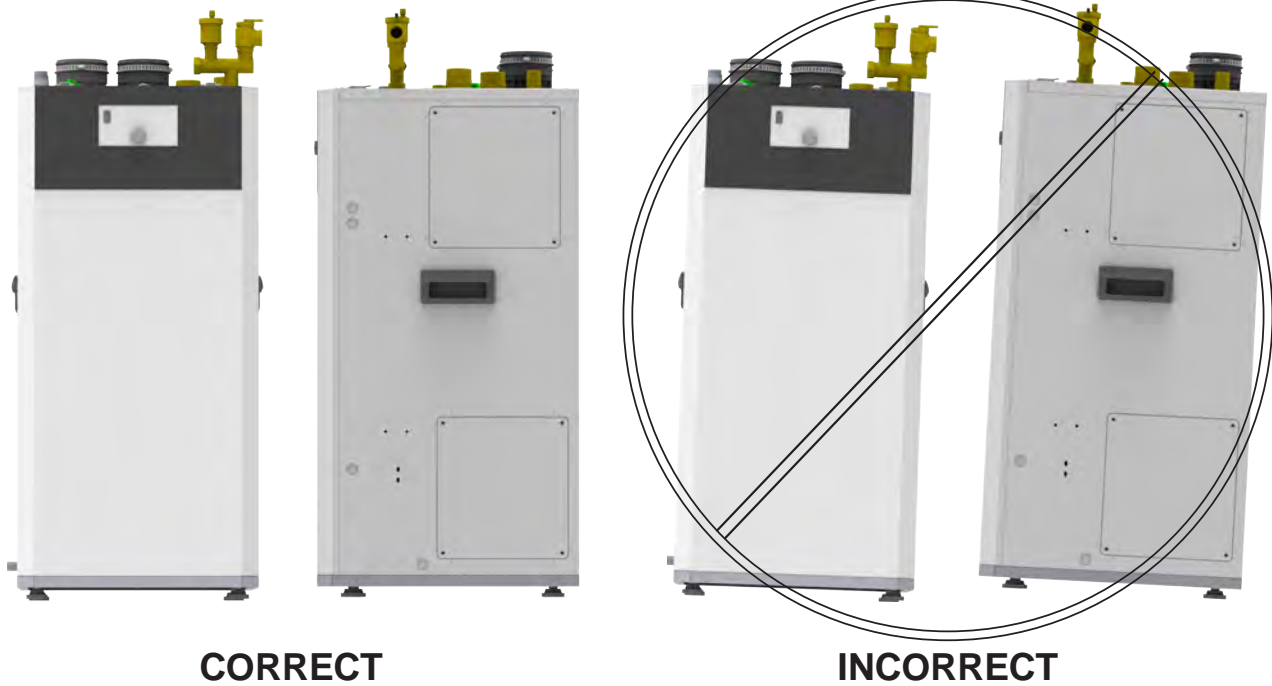

Boiler leveling feet are factory installed for your convenience.

* If small adjustments are required, tilt the boiler either to the left or right side and adjust the proper leveling feet.

Do NOT tip the boiler backwards or forwards as the protruding base on the front may interfere with the floor and may deform.

Note: When moving the boiler, use hand holds in left and right side panels to pick the boiler. Do not slide boiler along the floor on its boiler feet, as this may damage the feet.

4.3 Combustion Air

FT boilers must have provisions for combustion and ventilation air in accordance with the applicable requirements for Combustion Air Supply and Ventilation in the National Fuel Gas Code, ANSI Z223.1; or in Canada, the Natural Gas and Propane Installation Code, CSA B149.1. All applicable provisions of local building codes must also be adhered to.

A FT unit can take combustion air from the space in which it is installed, or the combustion air can be ducted directly to the unit. Ventilation air must be provided in either case.

4.3.1 Combustion Air from Room

In the United States, the most common requirements specify that the space shall communicate with the outdoors in accordance with method 1 or 2, which follow. Where ducts are used, they shall be of the same cross-sectional area as the free area of the openings to which they connect.

Method 1: Two permanent openings, one commencing within 12" (300mm) of the top and one commencing within 12" (300mm) of the bottom, of the enclosure shall be provided. The openings shall communicate directly, or by ducts, with the outdoors or spaces that freely communicate with the outdoors. When directly communicating with the outdoors, or when communicating to the outdoors through vertical ducts, each opening shall have a minimum free area of 1 square inch per 4000 Btu/hr (550 square mm/kW) of total input rating of all equipment in the enclosure. When communicating to the outdoors through horizontal ducts, each opening shall have a minimum free area of not less than 1 square inch per 2000 Btu/hr (1100 square mm/kW) of total input rating of all equipment in the enclosure.

Method 2: One permanent opening, commencing within 12" (300mm) of the top of the enclosure, shall be permitted. The opening shall directly communicate with the outdoors or shall communicate through a

vertical or horizontal duct to the outdoors or spaces that directly communicate with the outdoors and shall have a minimum free area of 1 square inch per 3000 Btu/hr (734 square mm/kW) of the total input rating of all equipment located in the enclosure. This opening must not be less than the sum of the areas of all vent connectors in the confined space.

Other methods of introducing combustion and ventilation air are acceptable, providing they conform to the requirements in the applicable codes listed above.

In Canada, consult local building and safety codes or, in absence of such requirements, follow CAN/CGA B149.1

4.3.2 Ducted Combustion Air

The combustion air can be taken through the wall, or through the roof. When taken from the wall, it must be taken from out-of-doors by means of the horizontal wall terminal. When taken from the roof, a field-supplied rain cap or an elbow arrangement must be used to prevent entry of rain water.

Use ABS, PVC, CPVC, polypropylene, or galvanized pipe for the combustion air intake. Route the intake to the boiler as directly as possible. Seal all joints. Provide adequate hangers at every 4 foot interval and at every elbow for proper support. The unit must not support the weight of the combustion air intake pipe. Maximum linear pipe length allowed is shown in Table 5. (See page 21). Subtract the required deduction in length for each installed elbow as per Table 5.

The connection for the intake air pipe is at the top of the unit.

In addition to air needed for combustion, air shall also be supplied for ventilation, including air required for comfort and proper working conditions for personnel.

COMBUSTION AIR INSTALLATION STANDARDS

MATERIAL	UNITED STATES	CANADA
ABS	ANSI/ASTM D1527	Air pipe material must be chosen CPVC, sch 40, ANSI/ASTM, Polypropylene based upon the intended application of the boiler.
PVC, sch 40	ANSI/ASTM D1785 or D2665	
CPVC, sch 40	ANSI/ASTM F441	
Polypropylene	UL1738, ULC S636.	
Single wall galv. steel	26 gauge	

Table 2. Required Combustion Air Pipe Material.

⚠ NOTICE

The instructions for the installation of the venting system shall specify that the horizontal portions of the venting system shall be supported to prevent sagging; the methods of and intervals for support shall be specified. These instructions shall also specify that the venting system:

Category I, II and IV boilers must be installed so that horizontal sections have an upward slope away from the boiler of at least ¼ inch per foot (21 mm/m) to prevent accumulation of condensate; and For Category II and IV boilers, where necessary, have means provided for drainage of condensate.

⚠ NOTICE

For long, trouble free operation, it is critical that the FT unit has always access to clean combustion air, either drawn from an inside space (per section 4.3.1) or external (per section 4.3.2).

- Do NOT allow contaminated indoor air (either by internal dust, sheet rock, PVC or CPVC pipe debris dust or similar contamination) to be drawn in through the air intake connection. If the unit must operate under job site conditions, always ensure availability of fresh air and protect the unit accordingly.
- For ducted combustion air from the outdoors, follow the guidelines provided in Sections 4.6 through 4.8 and make sure that clean air is always available for combustion.
- During assembly of the air intake system, make sure that any PVC or CPVC pipe debris due to cutting pipe is fully removed and all connecting surfaces are smooth and free of contamination.
- Visually inspect air intake piping for interior debris or shavings. It may be necessary to wash out the air intake piping.

⚠ CAUTION

When an existing Cat I appliance is removed or replaced, the original venting system may no longer be sized to properly vent the attached appliances. Under no circumstances should an improperly sized vent be used. An improperly sized vent may cause operational and safety problems, and could result in serious injury, death, or property damage.

⚠ AVIS

Les instructions d'installation du système d'évacuation doivent préciser que les sections horizontales doivent être supportées pour prévenir le fléchissement. Les méthodes et les intervalles de support doivent être spécifiés. Les instructions doivent aussi indiquer les renseignements suivants:

les chaudières de catégories I, II et IV doivent présenter des tronçons horizontaux dont la pente montante est d'au moins ¼ po par pied (21 mm/m) entre la chaudière et l'évent; les chaudières de catégories II et IV doivent être installées de façon à empêcher l'accumulation de condensat;

et si nécessaire, les chaudières de catégories II et IV doivent être pourvues de dispositifs d'évacuation du condensat.

⚠ CAUTION

- The FT is standard as a Natural Gas Boiler and must be converted if propane is the desired gas, using the furnished LP conversion kit.
- Adequate drainage
 - The appliance should be installed not to damage the adjacent area. If such locations cannot be avoided, it is recommended that a suitable drain pan, adequately drained, be installed under the appliance. The pan must not block combustion air flow.
- Connecting the Water Supply
 - To conserve water and energy, insulate all water piping—especially the hot and recirculation water lines. Never cover the drain or pressure relief valve. Having a backflow preventer in the cold water supply line will prevent thermal expansion backflow. Contact the water supplier or local plumbing inspector for information about how to control this situation.
- If overheating occurs or the gas supply fails to shut off, turn off the manual gas valve.
- This installation must conform with below section
 - “Air for Combustion and Ventilation” of the National Fuel Gas Code, ANSI Z224.1/NFPA 54, or Sections 8.2, 8.3 or 8.4 of Natural Gas and Propane Installation Code, CAN/CSA B149.1, or applicable provisions of the local building codes.

4.4 Venting (Exhaust)

⚠ NOTICE

DO NOT COMMON VENT FT UNITS. FT units are never permitted to share a vent with Category I appliances.

⚠ AVIS

NE PAS ÉVENT COMMUNE FT UNITÉS. FT unités ne sont jamais autorisés à partager un évent Catégorie I avec les appareils.

The flue temperature of the FT changes dramatically with changes in operating water temperature. Therefore, it is necessary to assess the application of the boiler to determine the required certified vent class. If the FT is installed in an application where the ambient temperature is elevated, and/or installed in a closet/alcove, CPVC, polypropylene, or stainless steel material is required. If the system temperatures are unknown at the time of installation, stainless, polypropylene or CPVC material is recommended.

The FT is a Category IV appliance and may be installed with PVC, CPVC or polypropylene (PP) and PP Flex that complies with ULC-S636, ANSI/ASTM D1785 F441 (see Table 3) or a stainless steel venting system that complies with UL 1738 Standard and ULC S636.

⚠ WARNING

Failure to use the appropriate vent material, installation techniques, glues/sealants could lead to vent failure causing property damage, personal injury or death.

⚠ WARNING

All venting must be installed according to this manual and any other applicable local codes, including but not limited to, ANSI Z224.1/NFPA 54, CAN/CSA B149.1 and ULC-S636. Failure to follow this manual and applicable codes may lead to property damage, severe injury, or death.

⚠ WARNING

Use of cellular core PVC (ASTM F891), cellular core CPVC, or Radel® (polyphenolsulfone) used in non-metallic venting systems is prohibited.

Non-metallic vent pipe (PVC, CPVC, (PP), PP Flex or other) shall NOT be insulated or covered. Insulating or covering non-metallic venting may cause overheating which diminishes the integrity of the pipe.

INSTALLATIONS IN CANADA require the use of venting material certified to ULCS636. All Gas vents connected to the FT, plastic, stainless steel or otherwise must be certified to this ULC standard. Appropriate selection of vent material is very important for proper performance and safe operation of the FT.

The flue temperature of the FT changes dramatically with changes in operating water temperature. Therefore, it is necessary to assess the application of the boiler to determine the required certified vent class. If the FT is installed in an application where the outlet water temperature exceeds 145°F, and/or installed in a closet, class IIB or higher vent material is required. If the system temperatures are unknown at the time of installation, class IIB or higher venting material is recommended.

IN CANADA all venting used must meet the following requirements:

- 1. ULC-S636 certified and marked**
- 2. The first 3 feet of venting must be accessible for visual inspection.**
- 3. All components used in the vent system must be from a certified manufacturer.**

VENTING INSTALLATION STANDARDS

MATERIAL	UNITED STATES	CANADA
Stainless Steel	UL 1738	Venting must be ULC-S636 certified for use as venting material. The venting material must be chosen based upon the intended application of the boiler.
PVC, sch 40	ANSI/ASTM D1785	
CPVC, sch 40 Polypropylene (PP), PP Flex	ANSI/ASTM F441 UL1738 or ULC-S636	

Table 3. Required Exhaust Vent Material.

4. **Venting system components can only be mixed with alternate manufacturers' certified components when clearly listed in the manufacturers Installation Manual.**
5. **The venting must be installed according to the vent manufacturers installation instructions.**

The unit's vent can terminate through the roof, or through an outside wall.

Vent pipe must pitch upward, toward the vent terminal, not less than 1/4" per foot, so that condensate will run back to the FT to drain. Route vent pipe to the boiler as directly as possible. Seal all joints and provide adequate hangers as required in the venting system manufacturer's Installation Instructions. Horizontal portions of the venting system must be supported to prevent sagging and may not have any low sections that could trap condensate. The unit must not support the weight of the vent pipe.

WARNING

- Failure to vent this Boiler in accordance with these instructions could cause a fire, resulting in severe property damage, personal injury or death.
- Do not interchange vent systems or materials unless it is specified.
- The use of thermal insulation covering pipe and fittings is prohibited.
- Do not apply an electric damper, draft hood or vent damper with this Boiler.
- Do not locate vent termination where exposed to prevailing winds. Moisture and ice may fall on surface around vent termination. To prevent deterioration, surface must be in good repair (sealed, painted, etc.).

4.5 General Location Guideline

1. Vent system installation must be in accordance with Local codes or, in the absence of local codes, the National Fuel Gas Code, ANSI Z224.1 /NFPA 54 and/or CSA B149.1, Natural Gas and Propane Installation Code.
 2. The Boiler is designed to be installed as a Direct Vent (sealed combustion) type. The air for combustion must be supplied directly from the outside to the burner. Also, the flue gases must be vented directly to the outdoors (through wall or roof).
 3. Do not install venting system components on the exterior of building except as specifically required by these instructions
 - Vent terminals must be at least 1 foot from any door, window, or gravity inlet into the building.
 - Maintain the correct clearance and orientation between the vent and air intake terminals. The vent and air intake terminals must be at the same height and their center lines must be spaced apart 12" minimum.
 - The bottom of the vent and air intake terminal must be at least 12" above the normal snow line. In no case should they be less than 12" above grade level.
- Do not install the vent terminal directly over windows or doors.
 - Air intake terminal must not terminate in areas that might contain combustion air contaminants, such as near swimming pools.
 - For sidewall venting, the minimum horizontal distance between any adjacent individual Module (Boiler) vent terminations is twelve (12) inches. It is better to be far more than 12 inches for avoiding frost damage to building surfaces where vent terminations are placed.
 - The minimum horizontal distance between any adjacent individual module (boiler) roof vent end piece is one (1) foot.
- The vent shall not terminate:
- over public walkways:
 - near soffit vents, crawl space vents or other areas where condensate or vapor could create a nuisance or hazard, or cause property damage:
 - where condensate or vapour could cause damage or could be detrimental to the operation of regulators, relief valves or other equipment.

4.6 Locations for Vent Pipe Terminator

	Canadian Installations ¹	U.S. Installations ²	
A =	Clearance above grade, veranda, porch, deck, or balcony	12 in (30 cm)	12 in (30 cm)
B =	Clearance to window or door that may be opened	<ul style="list-style-type: none"> 6 in (15 cm) for appliances ≤ 10,000 Btuh (3 kW) 12 in (30 cm) for appliances > 10,000 Btuh (3 kW) and ≤ 100,000 Btuh (30 kW) 36 in (91 cm) for appliances >100,000 Btuh (30 kW) 	<ul style="list-style-type: none"> 6 in (15 cm) for appliances ≤ 10,000 Btuh (3 kW) 9 in (23 cm) for appliances > 10,000 Btuh (3 kW) and ≤ 50,000 Btuh (15 kW) 12 in (30 cm) for appliances >50,000 Btuh (15 kW)
C =	Clearance to permanently closed window	See Note 4	See Note 5
D =	Vertical clearance to ventilated soffit located above the terminal within a horizontal distance of 2 ft (61 cm) from the center line of the terminal	See Note 4	See Note 5
E =	Clearance to unventilated soffit	See Note 4	See Note 5
F =	Clearance to outside corner	See Note 4	See Note 5
G =	Clearance to inside corner	See Note 4	See Note 5
H =	Clearance to each side of centerline extended above meter / regulator assy	3 ft (91 cm) within a height of 15 ft (4.6 m)	See Note 5
I =	Clearance to service regulator vent outlet	3 ft (91 cm)	See Note 5
J =	Clearance to nonmechanical air supply inlet to building or the combustion air inlet to any other appliance	<ul style="list-style-type: none"> 6 in (15 cm) for appliances ≤ 10,000 Btuh (3 kW) 12 in (30cm) for appliances > 10,000 Btuh (3 kW) and ≤ 100,000 Btuh (30 kW) 36 in (91 cm) for appliances ≤ 100,000 Btuh (30 kW) 	<ul style="list-style-type: none"> 6 in (15 cm) for appliances ≤ 10,000 Btuh (3 kW) 9 in (23cm) for appliances > 10,000 Btuh (3 kW) and ≤ 50,000 Btuh (15 kW) 12 in (30 cm) for appliances > 50,000 Btuh (15 kW)
K =	Clearance to a mechanical air supply inlet	6 ft (1.83 m)	3 ft (91 cm) above if within 10 ft (3 m) horizontally
L =	Clearance above paved sidewalk or paved driveway located on public property	7 ft (2.13 m)†	7 ft (2.13 m) for mechanical draft systems (Category I appliances). Vents for Category II and IV appliances cannot be located above public walkways or other areas where condensate or vapor can cause a nuisance or hazard*
M =	Clearance under veranda, porch, deck, or balcony	12 in (30 cm)‡	See Note 5

† A vent shall not terminate directly above a sidewalk or paved driveway that is located between two single family dwellings and serves both dwellings.
 ‡ Permitted only if veranda, porch, deck, or balcony is fully open on a minimum of two sides beneath the floor.

Notes:

- 1) In accordance with the current CSA B149.1, Natural Gas and Propane Installation Code.
- 2) In accordance with the current ANSI Z223.1/NFPA 54, Natural Fuel Gas Code.
- 3) If locally adopted installation codes specify clearances different than those illustrated, then the most stringent clearance shall prevail.
- 4) For clearances not specified in CAN/CSA-B149, clearance is in accordance with local installation codes and the requirements of the gas supplier.
- 5) For clearances not specified in ANSI Z223.1/ NFPA 54, clearance is in accordance with local installation codes and the requirements of the gas supplier.
- 6) IMPORTANT: Terminal must be placed such that it remains a minimum of 12" above maximum expected snow line. Local codes may have more specific requirements, and must be consulted.

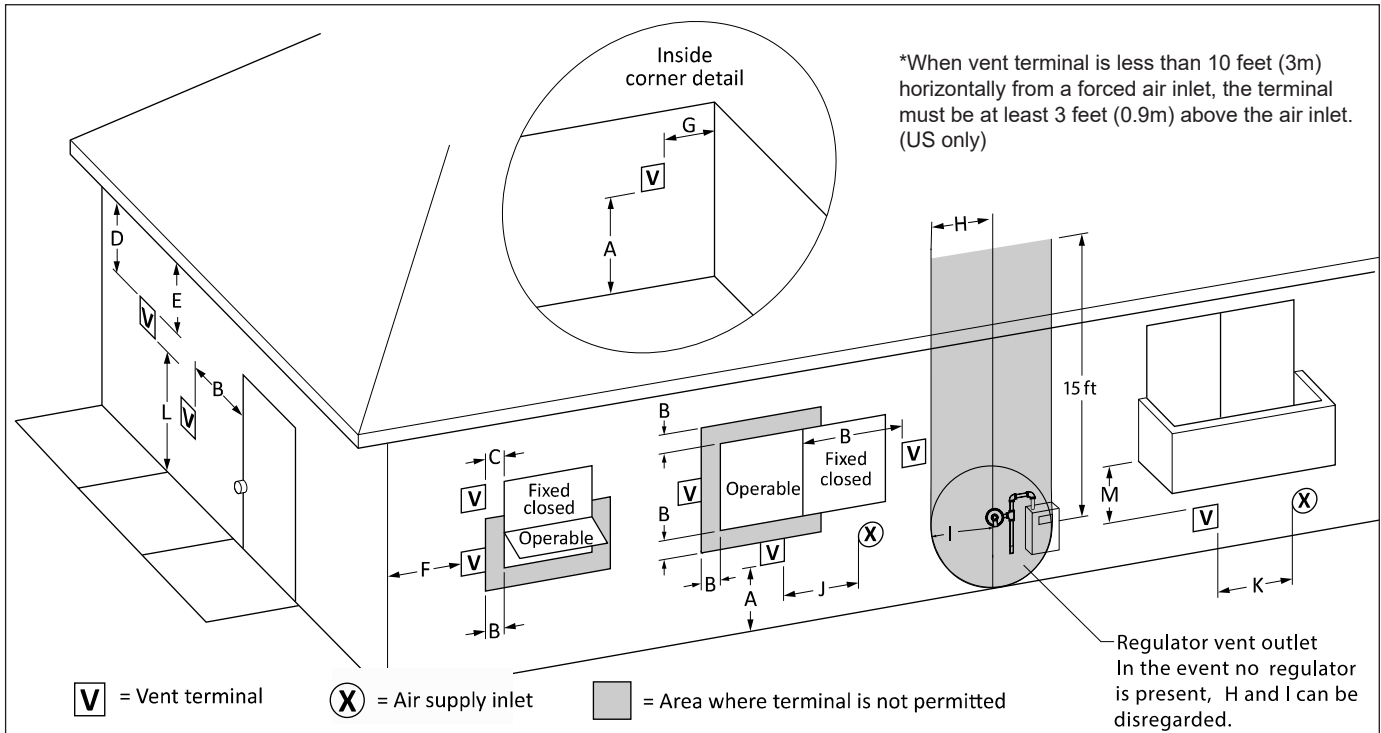

Table 4. Direct Vent Clearances

4.6.1 Venting Requirements in the Commonwealth of Massachusetts

In Massachusetts the following items are required if the side-wall exhaust vent termination is less than seven (7) feet above finished grade in the area of the venting, including but not limited to decks and porches. From Massachusetts Rules and regulations 248 CMR 5.08

1. Installation of Carbon Monoxide Detectors

At the time of installation of the side wall vented gas fueled appliance, the installing plumber or gasfitter shall observe that a hard-wired carbon monoxide detector with an alarm battery back-up is installed on the floor level where the gas appliance is to be installed. In addition, the installing plumber or gasfitter shall observe that a battery operated or hard-wired carbon monoxide detector with an alarm is installed on each additional level of the dwelling, building or structure served by the side-wall horizontally vented gas fueled equipment. It shall be the responsibility of the property owner to secure the services of qualified licensed professionals for installation of hard-wired carbon monoxide detectors.

a. In the event that the side-wall horizontally vented gas fueled equipment is installed in a crawl space or an attic, the hard-wired carbon monoxide with alarm and battery back-up may be installed on the next adjacent floor level.

b. In the event that the requirements of the subdivision cannot be met at the time of completion of installation, the owner shall have a period of thirty (30) days to comply with the above requirements, provided, however, that during said thirty (30) day period, a battery operated carbon monoxide detector with an alarm be installed.

2. Approved Carbon Monoxide Detectors. Each carbon monoxide detector shall comply with NFPA 720 and be ANSI/UL 2034 listed and IAS certified.

3. Signage. A metal or plastic identification plate shall be permanently mounted to the exterior of the building at a minimum height of eight (8) feet above grade directly in line with the exhaust vent terminal for horizontally vented gas fueled heating appliance or equipment. The sign shall read, in print no less than one-half (1/2) inch in size: "GAS VENT DIRECTLY BELOW, KEEP CLEAR OF ALL OBSTRUCTIONS".

4. Inspection The state or local gas inspector of the side-wall horizontally vented gas fueled appliance shall not approve the installation unless, upon inspection, the inspector observes carbon monoxide detectors and signage installed in accordance with the provisions of 248 CMR 5.08(2)(a) 1-4.

4.7 Common Vent Test

NOTE: This section does not describe a method for common venting FT units. It describes what must be done when an existing unit is **removed** from a common vent system.

NOTICE

At the time of removal of an existing boiler, the following steps shall be followed with each appliance remaining connected to the common venting system placed in operation, while the other appliances remaining connected to the common venting system are not in operation.

1. Seal any Not Used openings in the common venting system.
2. Visually inspect the venting system for proper size and horizontal pitch and determine there is no blockage or restriction, leakage, corrosion and other deficiencies which could cause an unsafe condition.
3. Insofar as is practical, close all building doors and windows and all doors between the space in which the appliances remaining connected to the common venting system are located and other spaces of the building. Turn on clothes dryers and any appliance not connected to the common venting system. Turn on any exhaust fans, such as range hoods and bathroom exhausts, so they will operate at maximum speed.
4. Place in operation the appliance being inspected. Follow the lighting instructions. Adjust thermostat so the appliance will operate continuously.
5. Operate the main burner for 5 minutes then, determine if the cut-draw overflows to the discharge opening. Use the flame of a match or a candle or the smoke of a cigarette, a cigar or a pipe
6. Once it has been determined, according to the method indicated above, that each device connected to the drainage system is placed in the open air in an adequate manner. Install the doors and windows, fans, the registers of chimneys and gas appliances to their original position
7. Any malfunction of the venting system should be corrected so that the installation conforms to the National Fuel Gas Code, ANSI Z223.1/NFPA 54 and (or) the installation codes CAN/CSA-B149.1. If the size of a section of the evacuation system must be changed, the system should be modified to comply with the minimum values of the relevant tables of appendix F of the National Fuel Gas Code, ANSI Z223.1/NFPA 54 and (or) the installation codes CAN/CSA-B149.1

NOTICE

DO NOT COMMON VENT FT UNITS. FT units are never permitted to share a vent with Category I appliances.

AVIS

Au moment du retrait d'une chaudière existante, les mesures suivantes doivent être prises pour chaque appareil toujours raccordé au système d'évacuation commun et qui fonctionne alors que d'autres appareils toujours raccordés au système d'évacuation ne fonctionnent pas:

1. Sceller toutes les ouvertures non utilisées du système d'évacuation.
2. Inspecter de façon visuelle le système d'évacuation pour déterminer la grosseur et l'inclinaison horizontale qui conviennent et s'assurer que le système est exempt d'obstruction, d'étranglement, de fuite, de corrosion et autres défaillances qui pourraient présenter des risques.
3. Dans la mesure du possible, fermer toutes les portes et les fenêtres du bâtiment et toutes les portes entre l'espace où les appareils toujours raccordés au système d'évacuation sont installés et les autres espaces du bâtiment. Mettre en marche les sècheuses, tous les appareils non raccordés au système d'évacuation commun et tous les ventilateurs d'extraction comme les hottes de cuisinière et les ventilateurs des salles de bain. S'assurer que ces ventilateurs fonctionnent à la vitesse maximale. Ne pas faire fonctionner les ventilateurs d'été. Fermer les registres des cheminées.
4. Mettre l'appareil inspecté en marche. Suivre les instructions d'allumage. Régler le thermostat de façon que l'appareil fonctionne de façon continue.
5. Faire fonctionner le brûleur principal pendant 5 min ensuite, déterminer si le coupe-tirage déborde à l'ouverture de décharge. Utiliser la flamme d'une allumette ou d'une chandelle ou la fumée d'une cigarette, d'un cigare ou d'une pipe.
6. Une fois qu'il a été déterminé, selon la méthode indiquée ci-dessus, que chaque appareil raccordé au système d'évacuation est mis à l'air libre de façon adéquate. Remettre les portes et les fenêtres, les ventilateurs, les registres de cheminées et les appareils au gaz à leur position originale.
7. Tout mauvais fonctionnement du système d'évacuation commun devrait être corrigé de façon que l'installation soit conforme au National Fuel Gas Code, ANSI Z223.1/NFPA 54 et (ou) aux codes d'installation CAN/CSA-B149.1. Si la grosseur d'une section du système d'évacuation doit être modifiée, le système devrait être modifié pour respecter les valeurs minimales des tableaux pertinents de l'appendice F du National Fuel Gas Code, ANSI Z223.1/NFPA 54 et (ou) les codes d'installation CAN/CSA-B149.1

AVIS

NE PAS ÉVENT COMMUNE FT UNITÉS. FT unités ne sont jamais autorisés à partager un évent Catégorie I avec les appareils.

4.8 Air Supply and Vent Connections

4.8.1 Vent / Air Pipe Lengths for dual pipe venting systems.

	2" Combustion Air & Vent Pipe			3" Combustion Air & Vent Pipe		
	Min. Combustion Air Pipe	Min. Vent Pipe	Max. Combustion Air & Vent Pipe	Min. Combustion Air Pipe	Min. Vent Pipe	Max. Combustion Air & Vent Pipe
FTCF 199 NG & LP	0 FT* (0 M)	3 FT (1 M)	50 FT (15 M)	0 FT* (0 M)	3 FT (1 M)	100 FT (30 M)
Deductions per 90° Elbow	8 FT (2.4 M)			5 FT (1.5 M)		
Deductions per 45° Elbow	4 FT (1.2 M)			2.5 FT (.75 M)		
Max. # of Total Elbows on Air Intake & Exhaust Vent	4			6		

Table 5. Maximum Vent / Air Pipe Lengths for either 3" or 2" Pipes (PVC schedule 40, CPVC schedule 40, SS, PP)

*Appliance needs to vent outdoors using approved vent caps and following all guidelines as noted in the Installation Manual.

NOTES:

- One must include all elbows on the air intake and exhaust piping in determining the maximum equivalent length of the air intake and exhaust vent piping.
- A total of 4 elbows matches the total number of elbows allowed for 2" venting.

Example: 2" venting system desired.

Air intake piping: Two 90 elbows and 15 ft of straight pipe: $2 \times 8 \text{ ft} + 15 \text{ ft} = 31 \text{ ft}$ (okay)

Exhaust vent piping: Two 90 elbows and 20 ft of straight pipe: $2 \times 8 \text{ ft} + 20 \text{ ft} = 36 \text{ ft}$ (okay)

NOTE: Proper protection against debris in the air intake (through using a downward spout and/or screen) to avoid debris pick-up / falling into the appliance is required.

4.8.2 Direct Venting

The FT boiler uses 3" or 2" diameter exhaust and 3" or 2" diameter intake air ducts. To ensure the draw of air directly from and exhaust of air directly to the outside of the building, create an airtight seal from the boiler collar to the vent termination.

(For installations in Canada) field-supplied plastic vent piping must comply with CAN/CSA B149.1 (latest edition) and be certified by the Standard For Type BH Gas Venting Systems, ULC-S636. Components of this listed system must not be interchanged with other vent systems or unlisted pipes or fittings. All plastic components and specified primers and glues of the certified vent system must be from a single system manufacturer and must not be intermixed with another system manufacturer's parts.

■ **Tightening — Boiler Collar (Socket) to Vent Pipe & Inlet Pipe**

- Clean and dry your selected PVC, CPVC vent pipe and boiler collar (socket).
- Push the pipe into the collar (socket) until it touches the bottom of the socket fitting.
- For 2" installations, install a field supplied 3" to 2" adaptor. Adaptor must be installed in vertical section of piping only.

3" pipe

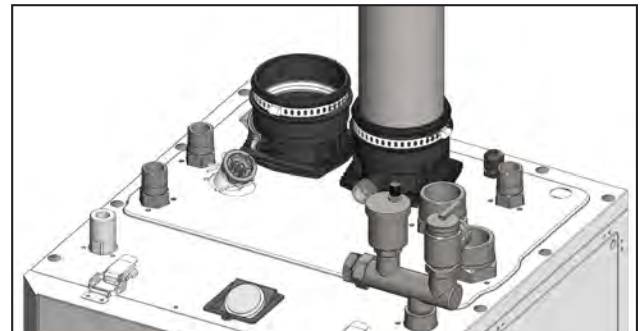

2" pipe connected, using an adapter

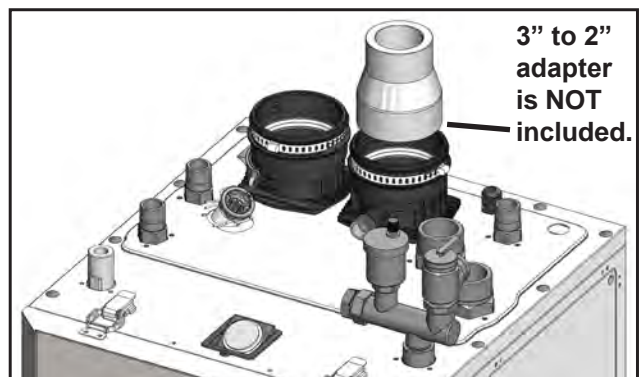

4.8.3 Indoor Combustion Air

Read and follow section 4.3 Guidelines first.

1. Insert the termination end cap into the intake air duct.
2. Provide two openings to allow for circulation of combustion air as specified by ANSI Z224.1/NFPA 54. In Canada refer to CAN/CSA B-149.1

NOTE: The FT needs fresh air for safe operation and must be installed so there are provisions for adequate combustion and ventilation air.

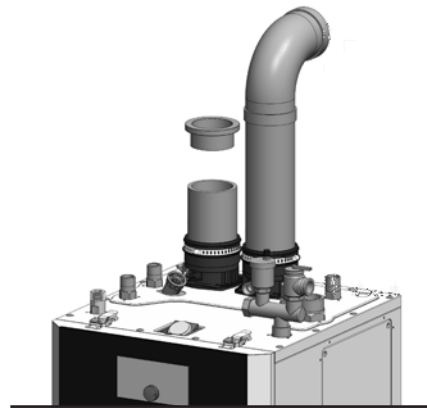

Model	FTCF199
Maximum Input (BTU/H)	199,000
Indoor make up air is provided, a minimum free area of 1 in 2 per 1,000 BTU/H	199 in ² 13 1/4" (W) x 13 1/4" (H)

4.9 Vent / Air Pipe Termination

Vent Air Terminations:

After connecting terminals install vent screens on both the vent and air inlet.

Two 3" vent screens are included with each unit. Additional replacement screens are available for purchase.

2" Vent Screen P/N - FT1508

3" Vent Screen P/N - FT1730

Vertical Vent Termination

- Direct Vent - Vertical Terminations with Sloped Roof



Vent Screens are required

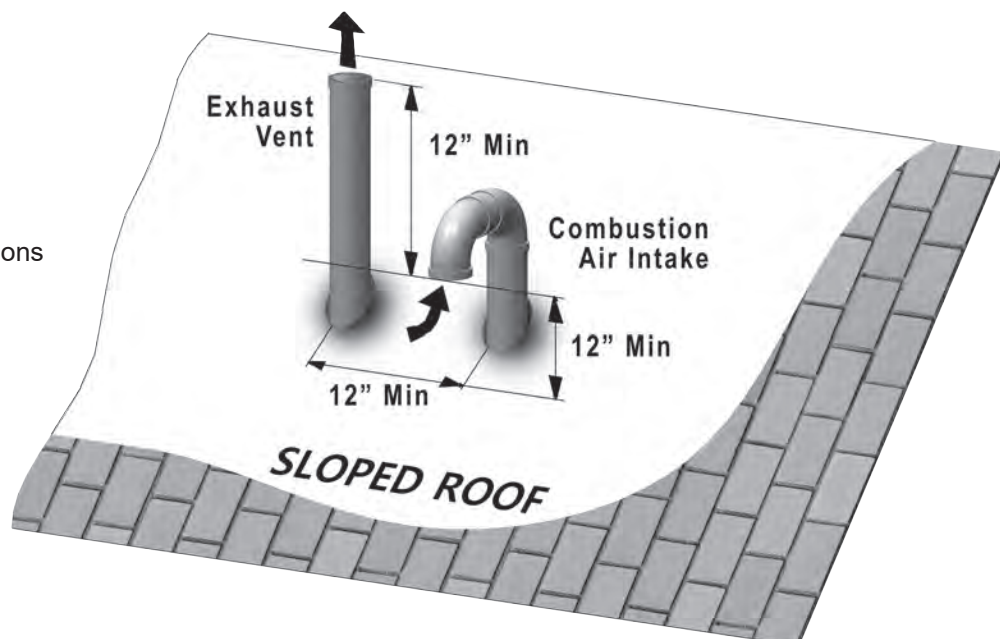

Horizontal Vent Termination

4.9 Vent / Air Pipe Termination (continued)

• Direct Vent - Sidewall Termination

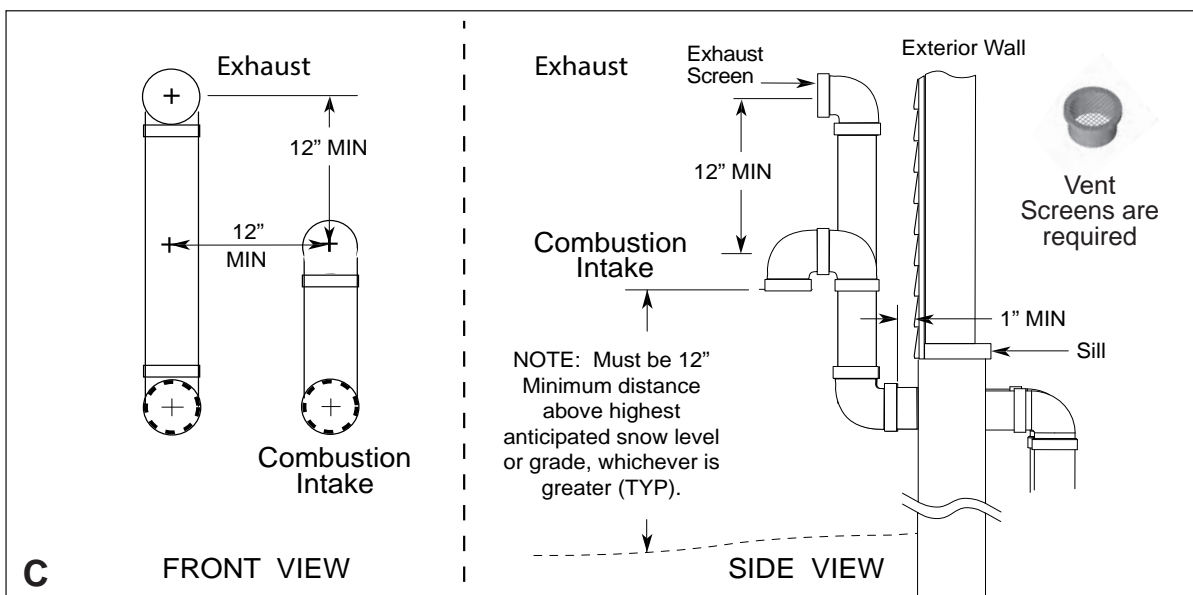
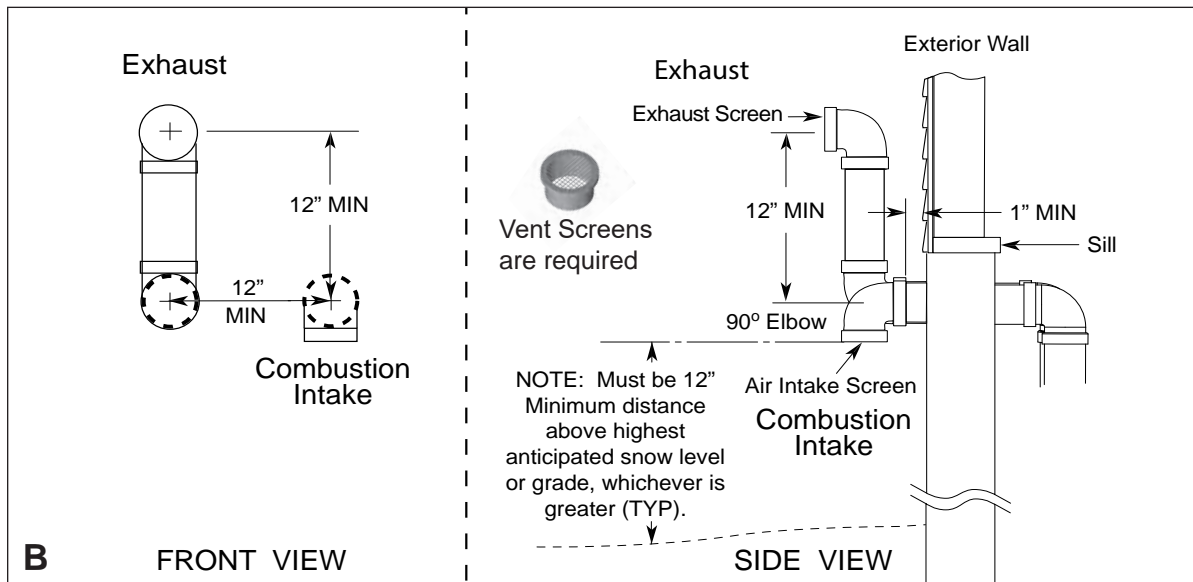
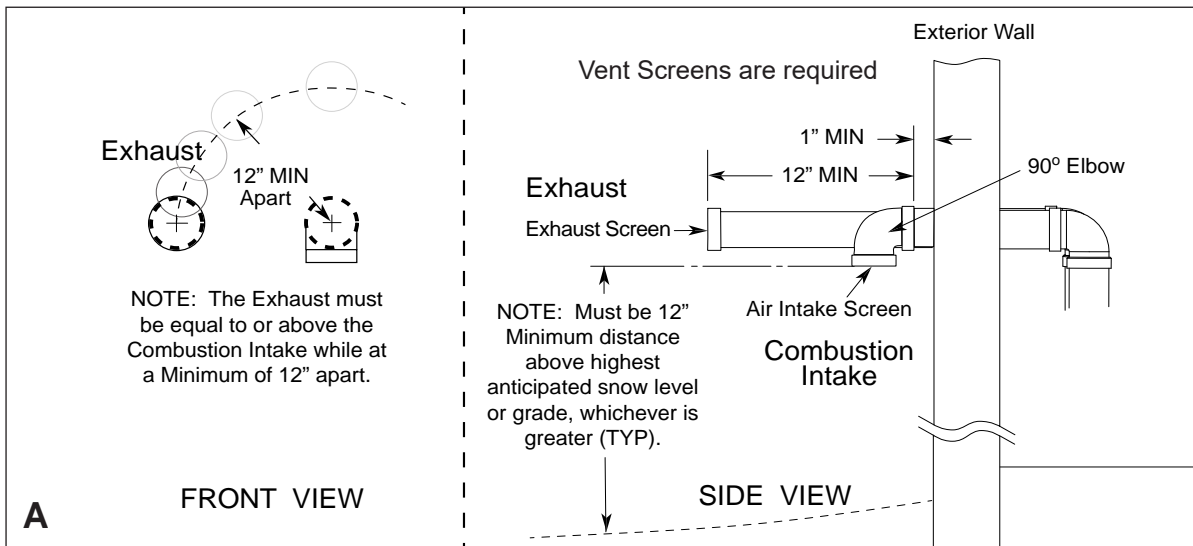

Concentric Vent Termination

- Direct Vent - Optional Horizontal and Vertical Concentric Vent

NOTE: Concentric Vent Terminations cannot be less than 12" apart in multi-unit installations. Consult local codes and the manufacturer's guidelines for acceptable separation distances.

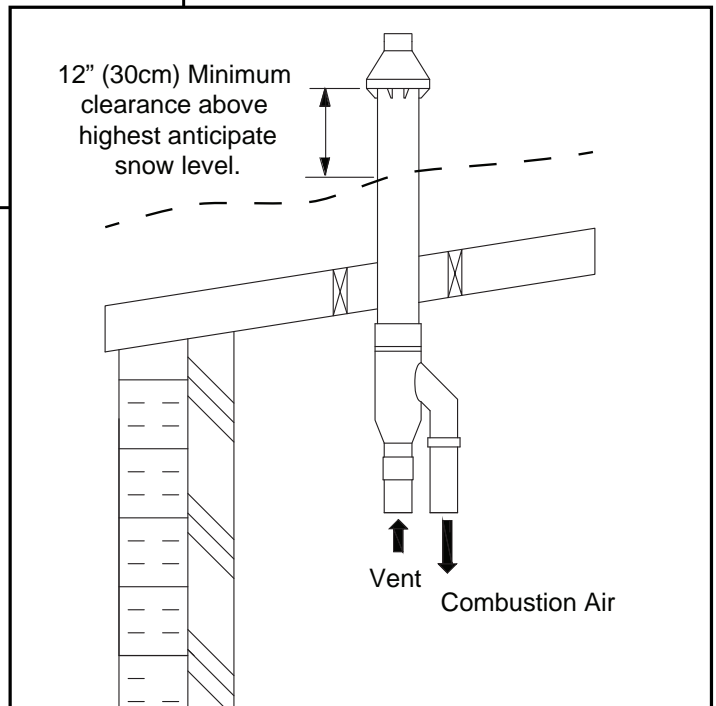
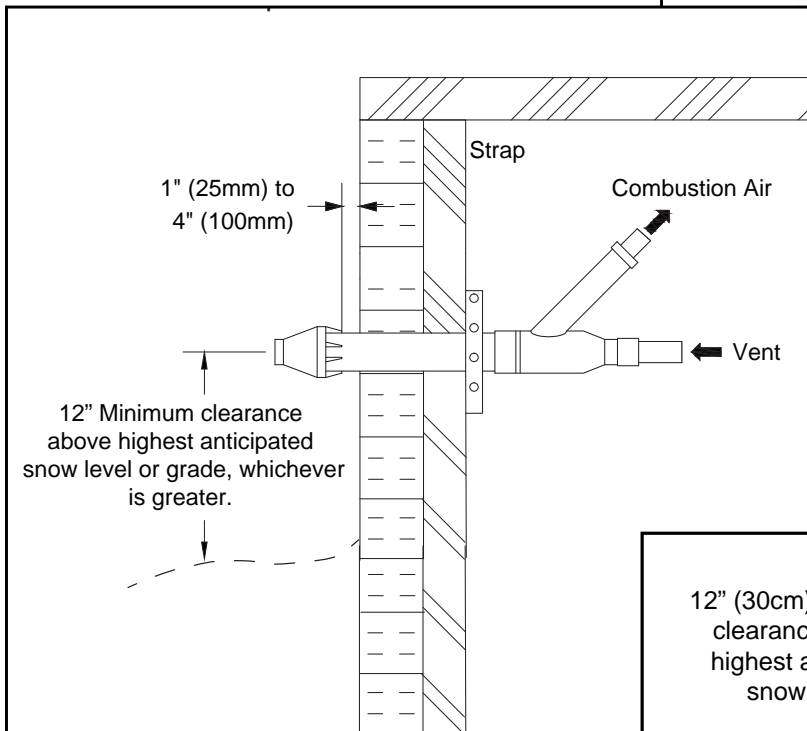
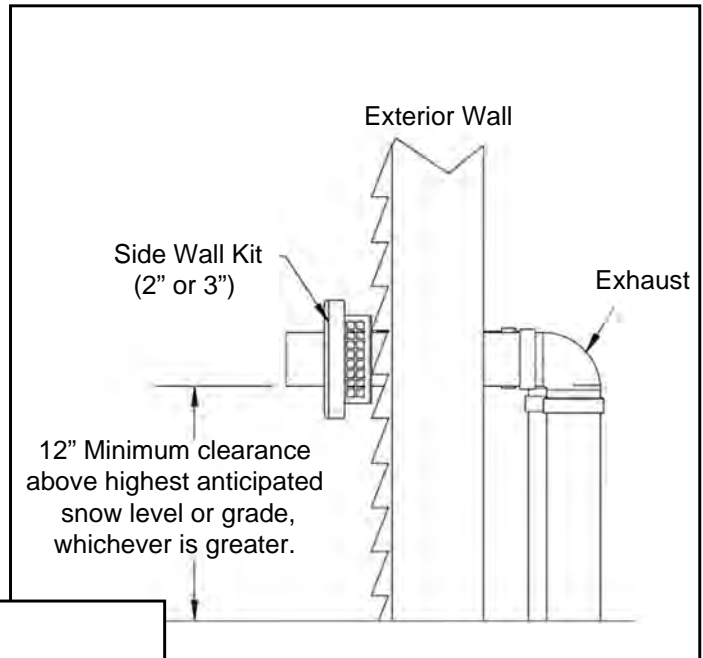

4.10.1 Concentric Venting Systems

The following concentric venting systems and components are approved for use with the FT floor standing boilers:

Table 6: Approved Heat-Fab SC series 3” x 5” stainless steel concentric venting components.

Heat Fab Part No.	Description	Part Number
	Dual pipe to concentric appliance adaptor	FT3006
SC03E90	3” x 5” 90° concentric elbow	
SC03E45	3” x 5” 45° concentric elbow	
SC03AJ	3” x 5” adjustable length pipe (12” to 18”)	
SCLO3L36	3” x 5” ft length concentric pipe	
SC03VT	3” x 5” vertical termination adaptor	
SC03RC	3” vertical rain cap	
SC03HT	3” x 5” horizontal termination adaptor	
9390TEE	3” Tee termination with screen	
9390	3” mitered termination with screen	
3 SCREEN TERMINATION	3” screen termination	

Table 7: Approved Duravent PolyPro (PP) 3” x 5” concentric venting material and special listed accessories.

Duravent Part Number	Description	Part Number
	PP Offset kit	FT3001
	PP Stub-out kit	FT3002
	PP to Heat-Fab adaptor	FT3003
	Telescopic concentric and 90°elbow kit	FT3004
3PPC-E90	3” x 5” concentric 90°elbow	
3PPC-P1000	3” x 5” concentric pipe 1000mm	
3PPC-P500	3” x 5” concentric pipe 500mm	
3PPC-VCT	3” x 5” concentric vertical termination	
3PPC-HCT	3” x 5” concentric horizontal termination	

Both concentric venting systems are approved for a total linear length of 25 ft and noted special adaptor and up to a maximum of 3 90° concentric elbows with either a horizontal or vertical concentric exhaust/intake termination. The entire venting system must slope back to the boiler to allow drainage of condensate. Please refer to Section 4.6 for approved termination locations for all applications.

Detailed installation instructions must be followed in this manual as outlined in the sections below. Only listed special accessories recorded in this manual are allowed for use in concentric venting applications.

Note: FT part numbers shown in Table 6 and 7 are directly available from your local FT boiler wholesaler or supplier.

4.10.2 Installation of a Complete New Concentric Stainless Steel Venting System.

For a vertical venting system, locate the boiler to affect the shortest possible vent length run with the maximum venting length not to exceed 25 feet and no more than 3 90° elbows.

Venting Assembly Process:

Note: Follow the detailed instructions supplied with the Heat-Fab SC series venting components during the assembly process.

1) Install the Dual pipe to concentric adaptor, kit FT3006. Ensure that the fittings are clean, moisten the seals and pipe ends before insertion and insert the Dual pipe to concentric adaptor, kit FT3006 into the FT boiler sockets until they bottom out. Tighten the clamps on the boiler vent connectors.

2) The venting system will probably have both horizontal and vertical components to align the Dual pipe to concentric adaptor, kit FT3006, and the penetration through the roof.

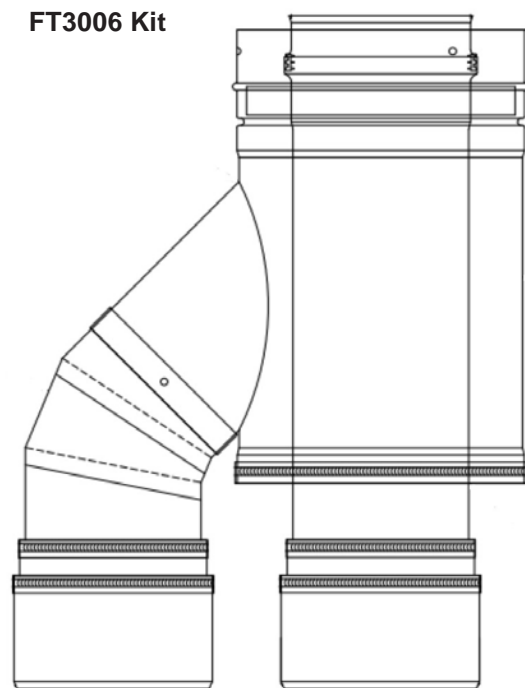

3) The selection on the roof for the roof termination must follow the guidelines of Section 4.9 Vent / Air Termination, Page 22 in this manual.

4) Locate the FT boiler as close as possible to the site of the roof termination overhead and determine the routing of the venting system and measure the required lengths of horizontal and vertical runs.

5) Properly support each horizontal and vertical section at least every 4 ft and at each elbow. Finish the vertical section by the installation of the SCO3VT Vertical Terminal Adapter on the last piece of vertical concentric vent pipe.. The top of this adapter must be 12" above the roof or anticipated snow line where it penetrates the roof. Install a SCO3RC, Rain Cap.

6) After completion of the venting system, review all joints of the venting installation and make sure that all locking screws of the adjoining vent sections are all fully installed into the pre-drilled holes.

For a horizontal venting system do not exceed the maximum allowed lengths and number of elbows noted above and select a location for the vent termination on the outside wall. This location must consider the 12" height above grade and/or anticipated snow line and its proximity to windows, doors and sources of incoming air, etc. Reference Section 4.6 Locations for Vent Pipe Terminator, Page 18 in this manual.

Venting Assembly Process:

Note: Follow the detailed instructions supplied with the Heat-Fab SC series venting components during the assembly process.

1) Locate the FT boiler as close as possible to the selected location for the penetration through the outside wall and install the Dual pipe to concentric adaptor, FT3006 kit, in the sockets on the FT boiler. Ensure that the fittings are clean, moisten the seals and pipe ends before insertion and insert the Dual pipe to concentric adaptor, FT3006 kit, into the FT boiler sockets until they bottom out.

2) Determine the routing of the venting system and measure the required lengths of horizontal and vertical runs. Keep in mind that telescoping pieces may be required for certain lengths as the pipes can NOT be trimmed to length. Each vertical and horizontal run must be supported by hangers every 4 ft so that it slopes 3/8" per foot downward toward the FT boiler and has no low sections that will limit the flow of condensate back to the boiler.

3) The telescoping sections are used to adjust both the vertical and the horizontal sections of the pipes so that the proper slope can be maintained.

4) Install the 3" x 5" horizontal termination adaptor (SCO3HT) on the last piece of horizontal concentric vent pipe protruding through the exterior wall and select one of the listed horizontal terminations to complete the concentric venting installation.

5) After completion of the venting system, review all joints of the venting installation and make sure that all locking screws of the adjoining vent sections are all properly installed.

4.10.3 Stainless-Steel Concentric Venting Utilizing Existing Stainless Steel Venting.

There might be existing boiler installations that have a Heat Fab SC 3" x 5" concentric venting system. It might be possible to re-use portions of that venting system.

Carefully inspect the original system before deciding to use it. The near boiler portions of the venting system will need to be replaced in order to connect to the new FT boiler.

Determine the routing of the venting system and measure the required lengths of horizontal and vertical runs. Keep in mind that telescoping pieces may be required as most piping sections can not be trimmed to length.

NOTE: If the existing vent system is horizontal and terminated by a "Vent Terminal Extension" on the outside wall of the building, that "Vent Terminal Extension" including a downward exhaust termination is not appropriate for a condensing boiler like the FT Boiler and the entire system will need to be replaced.

Refer to Section 4.10.2 for detailed instructions for installing a completely new concentric stainless steel venting system. (See Section 4.10.4 for installing a completely new concentric Duravent PP concentric venting system).

If the existing venting system is a horizontal run, the slope of that system will need to be changed. As installed, that system required a downward slope of $\frac{1}{4}$ " per foot toward the outside wall. The venting system for FT boiler requires a slope of $\frac{3}{8}$ " per foot back toward the boiler so that condensate will drain back to the boiler and be eliminated. To change the slope, the vent pipe hangers will need to be adjusted or replaced.

The centerline of the flue on the FT boiler is 3.9" (99 mm) from the back of the boiler cabinet. The centerline of the flue on the existing boiler is 9" (229 mm) from the back of the boiler cabinet. If the FT boiler can be installed so that its cabinet back is 5" (127 mm) further forward from the back wall than the existing boiler, then the FT boiler vent and the venting system will be in alignment. If, however, the boiler location for the FT boiler, with respect to the back wall, cannot be

changed, 45° offset fittings will be required to bring the centerline of the FT vent forward to align with the existing vent assembly.

Venting Assembly Process:

NOTE: Follow the detailed instructions supplied with the Heat-Fab SC series venting components during the assembly process.

1) Start the vent assembly process by installing the Dual pipe to concentric adaptor, kit FT3006. (See previous page). Ensure that the fittings are clean, moisten and insert the Dual pipe to concentric adaptor into the FT boiler sockets until they bottom out. Tighten the clamps on the boiler vent connectors.

2) To create the offset, if necessary, moisten the internal gasket and insert the plain end of a SCO3E45 fitting into the socket end of another. Take care that the orientation is such that the offset is as indicated and the inserted end bottoms out in the other socket fitting. Install the self-tapping screws into the predrilled holes.

3) If the offset is required, clean mating surfaces with alcohol swap provided and moisten the socket gasket on the SCO3E45 assembly, and install the assembly onto the Dual pipe to concentric adaptor and secure with self-tapping screws. Clean with the swap and moisten with water. Moisten the seals on all the other seals throughout the Venting System assembly, as you move on.

4) The transition between the Dual pipe to concentric Adapter and the existing vent system will be made with P/N SCO3AJ telescoping adjustable concentric straight length to adjust to the difference between the location of the top of the Dual pipe to concentric Adapter and the bottom of the existing vent system. This adjustable length pipe is required regardless if the offset fittings are required or not. Install the SCO3AJ and adjust the length to connect to the remaining parts of the existing vent system and secure by installing the self-tapping screws in the pre-drilled openings.

5) After adjusting the slope, install a SCO3E90 elbow and a SCO3AJ telescoping adjustable concentric straight length to adjust to the existing horizontal venting. Adjust the SCO3AJ to connect to the existing vent system and secure by installing the self-tapping screws in the pre-drilled openings. (Refer to Table 6, page 25, for component descriptions).

4.10.4 New Installation of Duravent PPS Concentric System

The FT boiler has separate Combustion Air and Vent connections. Using the Parts Kits indicated in Table 7, the FT boiler can be connected with a Polypropylene Concentric Vent System for horizontal and vertical venting applications. Note that the entire venting system must slope back to the boiler 3/8" per foot for proper drainage of condensate. Do NOT allow any sags in the venting system.

For a vertical venting system, locate the FT Boiler as close as possible to the chosen vent location overhead, on the roof. The selection of the location for the roof termination must follow the guidelines of Section 4.9 Vent / Air Termination, Page 22.

For a horizontal venting system, locate the FT Boiler as close as possible to the chosen vent site near the outside wall of the building. This location must consider the 12" height above grade and/or maximum anticipated snow line and its proximity to windows, doors and sources of incoming air, etc. Reference Section 4.6 Locations for Vent Pipe Terminator, Page 18.

Venting Assembly Process:

Determine the routing of the venting system and measure the required horizontal and vertical runs. Keep in mind that telescoping pieces may be required as most piping sections can not be trimmed to length. Hangers and supports must be used every 4 ft so that the venting system slopes down back to the FT boiler by 3/8" per ft and no sags can be present in the venting system. Start the installation by installing the FT3002 Stub Out Kit directly in the FT Boiler Combustion Air and Vent connectors..

The 2 PP pieces of the FT3002 kit can be reduced in length, make sure to cut the exact same length from each piece, not to exceed 6-1/2". Assemble the parts

Stub-out Kit FT3002

ITEM NUMBER	QUANTITY	PART NUMBER	Description
1	1	820014497	Concentric Adaptor 80/80 - 80/125
2	1	820001613	3" Diameter PP 12" Pipe Length
3	1	820019072	3" Diameter PP 17.75" Pipe Length
4	2	810004167	3" Diameter 3" PVC Male to 3" PP
5	1	810004128	3" Diameter PVC Adaptor Clamp

in the following order:

1) Insert a stainless steel to PP adaptor, (#4), into each of the FT boiler sockets and ensure that they bottom out in the sockets. Moisten the seals on the sockets to make the insertion easier and to avoid damaging the seals. Tighten the clamps on boiler vent connectors.

2) Insert item 820019072, (#3), 17.75" Straight Length, plain end through the top of the, (#1), Concentric Adapter. Do not connect it to the FT Boiler at this point.

3) Insert item 820001613, (#2), 12" Straight Length, into the stainless steel to PP adaptor on the Combustion Air socket and tighten the clamp.

4) Place the Concentric Adaptor, (#1), on top of the 12" pipe and align it so that the 17.75" PP pipe is aligned with the Vent socket on the FT Boiler.

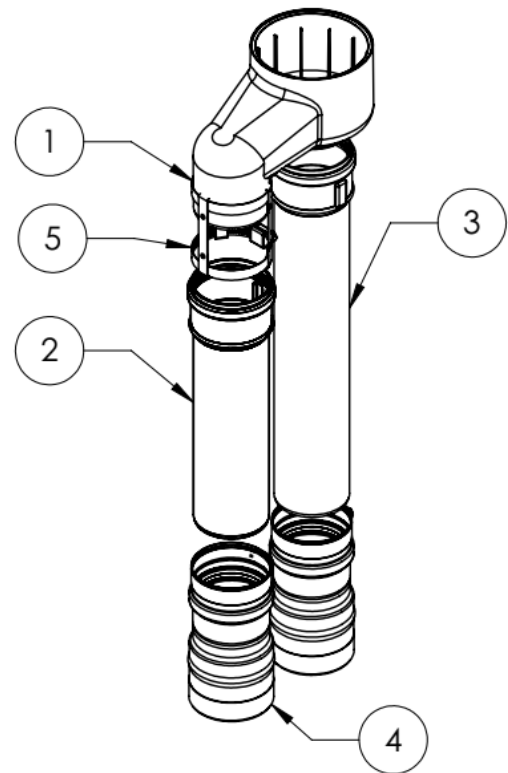
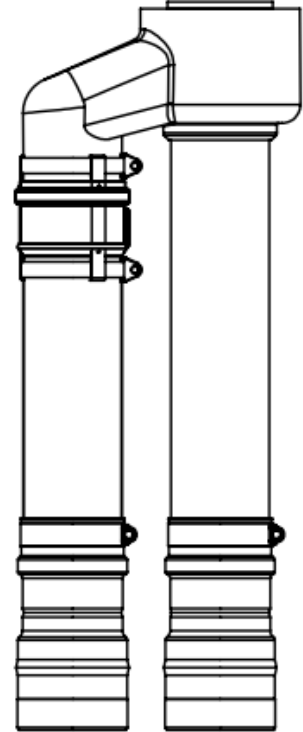

Slide the 17.75" pipe down through the stainless steel to PP adapter and connect it to the adapter on the FT boiler's Vent connection. Ensure that item #3 bottoms out and tighten the clamp.

5) Ensure that the 12" PP pipe is bottomed out in the P/N 820014497, (#1), and install the PVC Adaptor Clamp, (#5), Clamp and tighten both ends.

6) Place an 810005870, (#2), 3X5 Concentric Telescopic from a FT3004 Kit onto the FT3002 until it bottoms out.

FT3004 Concentric Telescopic piece + Elbow

ITEM NUMBER	QUANTITY	PART NUMBER	Description
1	1	810005865	3" x 5" Concentric 90° Elbow
2	1	810005870	3" x 5" Concentric Telescopic

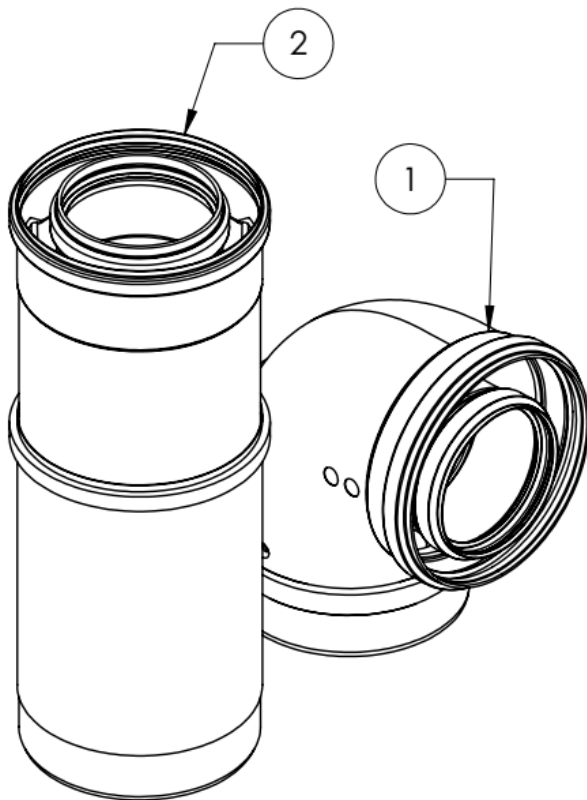

7) Add the 810005865, (#1), 3X5 Concentric 90° elbow from the FT3004 Kit until it bottoms out. Adjust the length of the telescopic section as required.

8) Additional concentric Duravent PP components can be purchased from your local wholesaler.

9) The system from this point onward will probably be comprised of horizontal and vertical components for a vertical system. Another FT3004 kit can be used to adjust the lengths of both the horizontal and the vertical components of the system.

10) The required length of the horizontal or vertical sections may be created with the addition of straight lengths of 3PPC-P500 (19.69") and/or 3PPC-P1000 Concentric Pipe (39.37").

11) A vertical system will be terminated with the 3" x 5" concentric vertical termination, 3PPC-VCT.

12) A horizontal venting system will be terminated with the 3"x5" concentric horizontal termination, 3PPC-HCT.

4.10.5 Duravent PPS Concentric System to an existing Heat-Fab SC venting system

Fully read these instructions in order to connect to an existing Heat-Fab SC concentric stainless steel concentric venting system. Before starting the actual installation work, determine the routing of the new venting components and where these parts will connect to the existing components.

There might be existing boiler installations that have a Heat Fab SC 3" x 5" concentric venting system. It might be possible to re-use portions of that venting system.

Carefully inspect the original system before deciding to use it. The near boiler portions of the venting system will need to be replaced in order to connect to the new FT boiler.

NOTE: If the existing vent system is horizontal and terminated by a "Vent Terminal Extension" on the outside wall of the building, that "Vent Terminal Extension" including a downward exhaust termination is not appropriate for a condensing boiler like the FT Boiler and the entire system will need to be replaced.

Refer to Section 4.10.2 for detailed instructions for installing a completely new concentric stainless steel venting system. (See Section 4.10.4 for installing a completely new concentric Duravent PP concentric

venting system).

If the existing venting system is a horizontal run, the slope of that system will need to be changed. As installed, that system required a downward slope of 1/4" per foot toward the outside wall. The venting system for FT boiler requires a slope of 3/8" per foot back toward the boiler so that condensate will drain back to the boiler and be eliminated. To change the slope, the vent pipe hangers will need to be adjusted or replaced.

The centerline of the flue on the FT boiler is 3.9" (99 mm) from the back of the boiler cabinet. The centerline of the flue on the existing boiler is 9" (229 mm) from the back of the boiler cabinet. If the FT boiler can be installed so that its cabinet back is 5" (127 mm) further forward from the back wall than the existing boiler, then the FT boiler vent and the venting system will be in alignment. If, however, the boiler location for the FT boiler, with respect to the back wall, cannot be changed, 45° offset fittings will be required to bring the centerline of the FT vent forward to align with the existing vent assembly.

The FT boiler has separate Combustion Air and Vent connections. Using the Parts Kits indicated in the following instructions, it can be connected with a PP Concentric Vent System.

If this 5" offset in the venting system is required, it can be achieved in 2 ways.

Option 1: Assemble the elbows in an FT3001 Elbow Kit to form two offset assemblies. Ensure that the elbows bottom out and tighten the clamps.

Option 2: Use 2 45° Duravent concentric elbows (3PPC-E45) and install them in off-set fashion into the concentric venting as described below.

Venting Assembly Process:

1) Start the installation by installing only the 2 stainless to PP adapters of the P/N FT3002 Stub Out Kit, directly in the FT boiler Combustion Air and Vent sockets. Ensure that all connections bottom out and tighten the clamps on the boiler vent connectors.

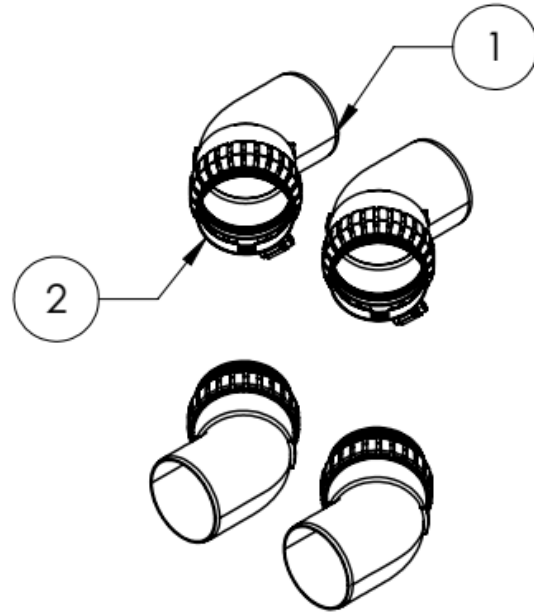

FT3001 Offset Kit

ITEM NUMBER	QUANTITY	PART NUMBER	DESCRIPTION
1	4	810014537	3" Dia 45° Elbow - Single Wall
2	4	810014538	3" Dia Locking Clamp

2) If the above mentioned 5" offset is required, install now the 2 pre-assembled off-set assemblies into each stainless to PP adaptor. Then install the 2 PP lengths into the Stub-out kit (FT3002)(Option 1 solution for off-set).

Note: Do not overtighten the connections until the entire system is put together.

3) If FT3001 Elbow kit is not required, the complete Stub-out kit (FT3002) can be installed or off-set option 2 is selected, the length of the 2 PP portions can be shortened; make sure to cut the same length from each pipe. Do not cut more that 6-1/2" from each pipe.

Assemble the parts in the following order:

4) Insert the 3" stainless steel to PP adapters into the 2 3" vent connections on top of the FT Boiler until they bottom out into the sockets.. Moisten the seals on the sockets to make the insertion easier and to avoid damaging the seals. Tighten the clamps on the boiler

Stub-out Kit FT3002

ITEM NUMBER	QUANTITY	PART NUMBER	Description
1	1	820014497	Concentric Adaptor 80/80 - 80/125
2	1	820001613	3" Diameter PP 12" Pipe Length
3	1	820019072	3" Diameter PP 17.750" Pipe Length
4	2	810004167	3" Diameter 3" PVC Male to 3" PP
5	1	810004128	3" Diameter PVC Adaptor Clamp

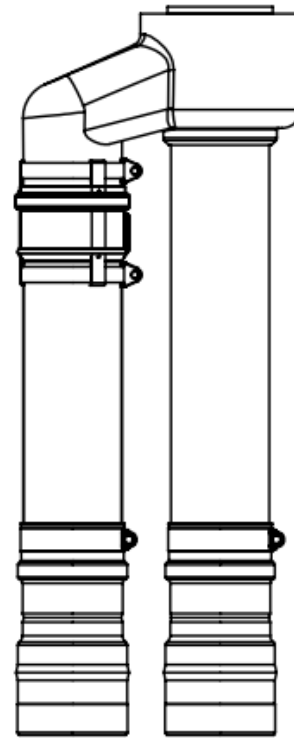
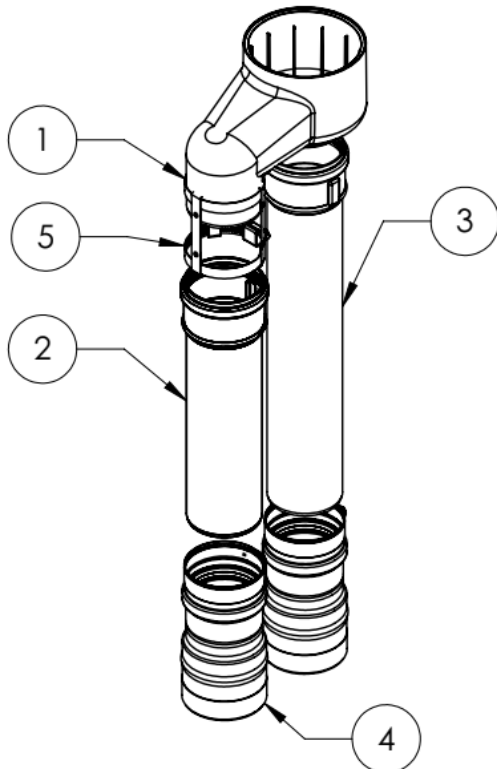

the clamp.

vent connectors.

5) Insert the, 17.75" Straight Length, plain end PP pipe through the top of the, (#1), concentric PP adaptor. Do not connect it to the FT boiler or FT3001 Elbow, if used, at this point.

6) Insert the straight length PP pipe, Into the adaptor on the Combustion Air socket or FT3001 Offset Elbows and tighten the clamp.

7) Place the (#1), Concentric adapter on top of the 12" pipe and align it so that the 17.75" pipe is aligned with the Vent socket on the FT boiler or the FT3001 Offset Elbow, if used. Slide the 17.75" pipe down through the adapter and connect it to the adapter on the FT boiler's Vent connection or the FT3001 Offset Elbow, if used. Ensure that it bottoms out and tighten

8) Ensure that the 12" pipe is bottomed out in the Concentric Adaptor, (#1), and install the, (#5), Clamp and tighten both ends.

9) Option 2 for offset (if required): Install 2 45 concentric PP elbows (3PPC-E45) in an off-set fashion on top of the concentric adaptor. Make sure the different components are fully engaged and bottom out.

10) Depending on where you need to connect to your existing Heat-Fab SC concentric venting system, use the components in the FT3004 kit to either vertically or horizontally adjust. (See page 29).

11) Use FT3003 kit (PP to Heat-Fab adaptor) to connect the Duravent PP concentric system to the existing Heat-Fab SC venting system. Moisten the seals with water prior to assembly. See image of FT3003 kit on the next page.

12) After completing the venting installation, review all joints, check for proper slope on each horizontal section and make sure each section is properly supported per vent manufacturer's instructions.

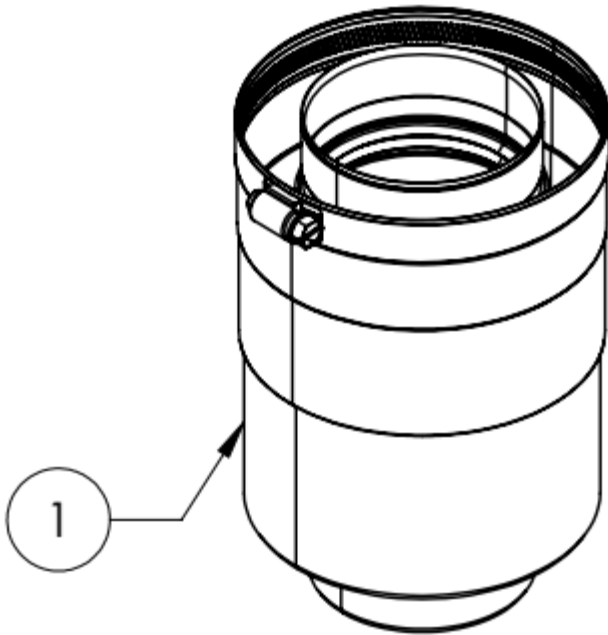
FT3003 PP to Heat-Fab Kit**Table 8: Approved components for use in 3" Vertical PP Flex venting.**

Part Number	Description
3PPS-FLEX50	3" Diameter 50' Flex PP
3PPS-FKC	3" Flex kit
3PPS-72C	3" 6' PP Pipe
3PPS-E90C	3" PP elbow
3PPS-03PVCM-3PPF	3" PVC Male to 3" PP
3PPS-FAC	3" Flex coupler
3PPS-FKC	3" Flex chimney lining kit

(Venting parts available through your local wholesaler).

4.10.6 Flexible Chimney Liner Venting

A masonry chimney may be used as a chase for vertically venting the FT boiler. The parts and instructions are available from DuraVent distributors. Please refer to the Table 8. The vent parts used within the chimney must all be PP Flex components and be installed in accordance with the detailed Installation Instructions provided with the parts. Those instructions are for the installation of the vent from the top of the chimney (including the Termination) to a point at the bottom of the chimney. From this point, use single wall PP pipe to connect to the exhaust connection on the boiler.

For FT Boilers replacing boilers utilizing B Vent chimneys, parts are also available to use the existing B Vent chimney as a chase for the PP Flex. As with the masonry chimney, the PP Flex is only used within the chimney and must be connected to rigid PP pipe from that point to the exhaust connection of the FT Boiler. Three (3) 90 degree elbows and up to 15 ft feet of rigid 3" PP pipe are allowed.

3" rigid PP pipe is required from the bottom of the PP Flex liner to the exhaust connection of the FT Boiler. The maximum allowable length of PP Flex pipe is 50 feet of three (3) inch diameter Flex pipe.

4.11 Gas Supply and Piping

Gas piping should be supported by suitable hangers or floor stands, by the appliance.

Review the following instructions before proceeding with the installation.

1. Verify that the appliance is fitted for the proper type of gas by checking the rating plate. FT will function properly at elevations up to 10,000 feet (3050 m). Refer to Section 4.13 for High Altitude Settings.
2. For minimum and maximum supply pressures, see Table 9 on page 36
3. Refer to Tables 6, 7 and 8 for proper gas pipe sizing.
4. Run gas supply line in accordance with all applicable codes.
5. Locate and install manual shutoff valves in accordance with state and local requirements.
6. A sediment trap must be provided upstream of the gas controls.
7. All threaded joints should be coated with piping compound resistant to action of liquefied petroleum gas.
8. The appliance and its individual shutoff valve must be disconnected from the gas supply piping during any pressure testing of that system at test pressures in excess of 1/2 PSIG (3.45kPa).
9. The unit must be isolated from the gas supply system by closing its individual manual shutoff valve during any pressure testing of the gas supply piping system at test pressures equal to or greater than 1/2 PSIG (3.45kPa).
10. The appliance and its gas connection must be leak tested before placing it in operation.
11. Purge all air from gas lines.

⚠ CAUTION

PRV (included) must be installed immediately at the top of boiler outlet to PRV, with no valves between. Refer to Section 4.16

⚠ ATTENTION

PRV (inclus) doit être installé immédiatement en haut de la chaudière sortie de PRV, sans les vannes entre. Se reporter à la Section 4.15

⚠ WARNING:

Open flame can cause gas to ignite and result in property damage, severe injury, or loss of life.

NOTE: The FT appliance and all other gas appliances sharing the gas supply line must be firing at maximum capacity to properly measure the inlet supply pressure. The pressure can be measured at the supply pressure port on the gas valve. Low gas pressure could be an indication of an undersized gas meter, undersized gas supply lines and/or an obstructed gas supply line.

SCH 40 METAL PIPE CAPACITY FOR 1.50 SPECIFIC GRAVITY UNDILUTED PROPANE			
NOMINAL PIPE SIZE @ 11" W.C. INLET AND 0.5" W.C. PRESSURE DROP			
SIZE	1/2"	3/4"	1"
LENGTH	MAXIMUM CAPACITY IN THOUSANDS OF BTU PER HOUR		
20	200	418	787
40	137	287	541
60	-	231	434
80	-	197	372
100	-	175	330

NOTES: 1. Follow all local and national propane gas codes for line sizing and equipment requirements. 2. Verify that inlet gas pressure remains between 4 and 13 inches of water column before and during operation.
Source: ANSI Z223.1-80 National Fuel Gas Code.

Table 6. Nominal Pipe Size, Propane

SCH 40 METAL PIPE CAPACITY FOR 0.60 SPECIFIC GRAVITY NATURAL GAS		
NOMINAL PIPE SIZE @ 0.30" W.C. PRESSURE DROP		
LENGTH	3/4"	1"
FT	CUBIC FEET OF GAS PER HOUR	
20	190	350
40	130	245
60	105	195
80	90	170
100		

Table 7. Nominal Pipe Size, Natural Gas

EQUIVALENT LENGTHS OF STRAIGHT PIPE FOR TYPICAL SCH 40 FITTINGS			
NOMINAL PIPE SIZE			
FITTING	1/2"	3/4"	1"
LINEAR FEET			
90° ELBOW	3.6	4.4	5.2
TEE	4.2	5.3	6.6

Table 8. Equivalent Pipe Lengths

4.11 Gas Supply and Piping (cont)

- The gas connection fitting is, **3/4" male NPT** on FTFCF199 models.
 - The supply line must be sized for the maximum output of the combination boiler model being installed. If there are additional gas appliances from the main supply line, you must measure connected on the same main gas supply line, according to the **COMBINED** total maximum BTUH draw for the appliances as if they were all operating at the same time.
 - Measure the length of the gas supply line from the gas meter to the Combination boiler. Use the tables in this manual or refer to the gas line manufacturers sizing information to determine the correct supply pipe size.
 - The manual gas shut-off valve in the gas supply line should be installed close to the unit as shown below.
- To facilitate any future maintenance, it is also recommended that an approved gas union fitting be installed in the supply line between the shut-off valve and the 3/4" male NPT connection on the Combination boiler.
 - 1) Install an approved gas line pipe to gas line connection gas Combination boiler . Include manual shut off valve and gas union on top of the connection, as shown.
 - 2) Test gas pressure to make sure it meets the minimum standards and does not exceed the maximum standards for the combination boiler.
 - 3) Leak test the gas line pipe before placing the unit in operation. Use approved leak detector liquid solutions only to check for leaks.
 - Do Not Operate the combination boiler until all connections have been completed, checked for leaks, and the heat exchanger is filled with water.

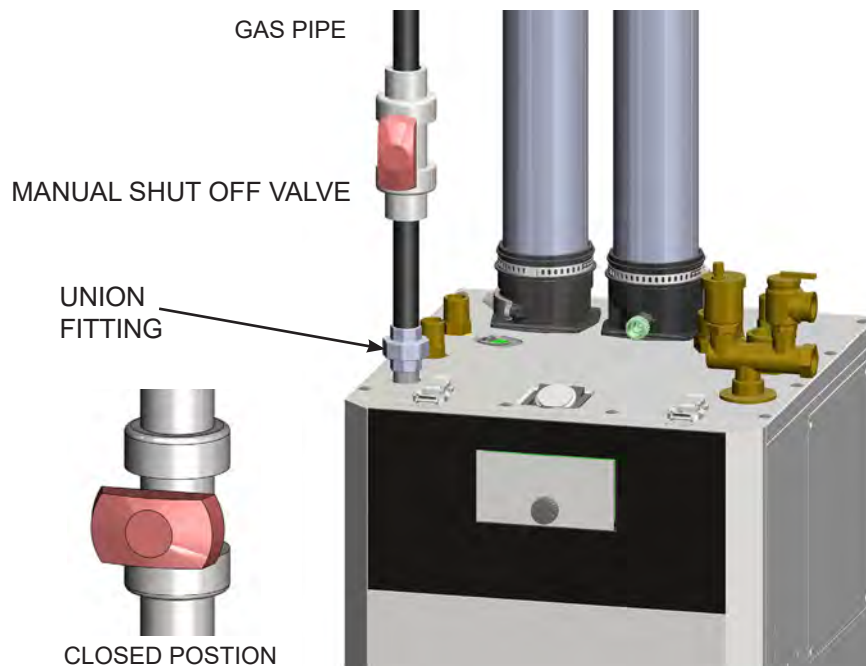

**Gas Line Shut Off
Valve Detail**

Suggested Natural Gas (NG) Layout

NOTE: Total gas supply capacity must not be less than the total demand capacity of the connected appliances.

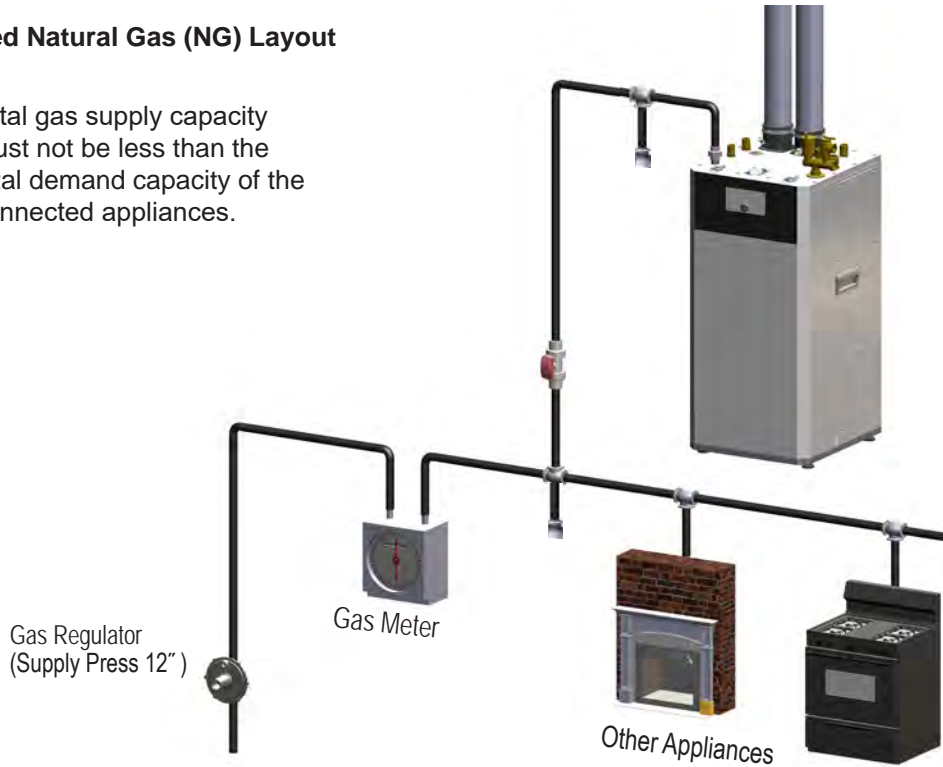

Suggested Propane Gas (LP) Layout

NOTE: Total gas supply capacity must not be less than the total demand capacity of the connected appliances.

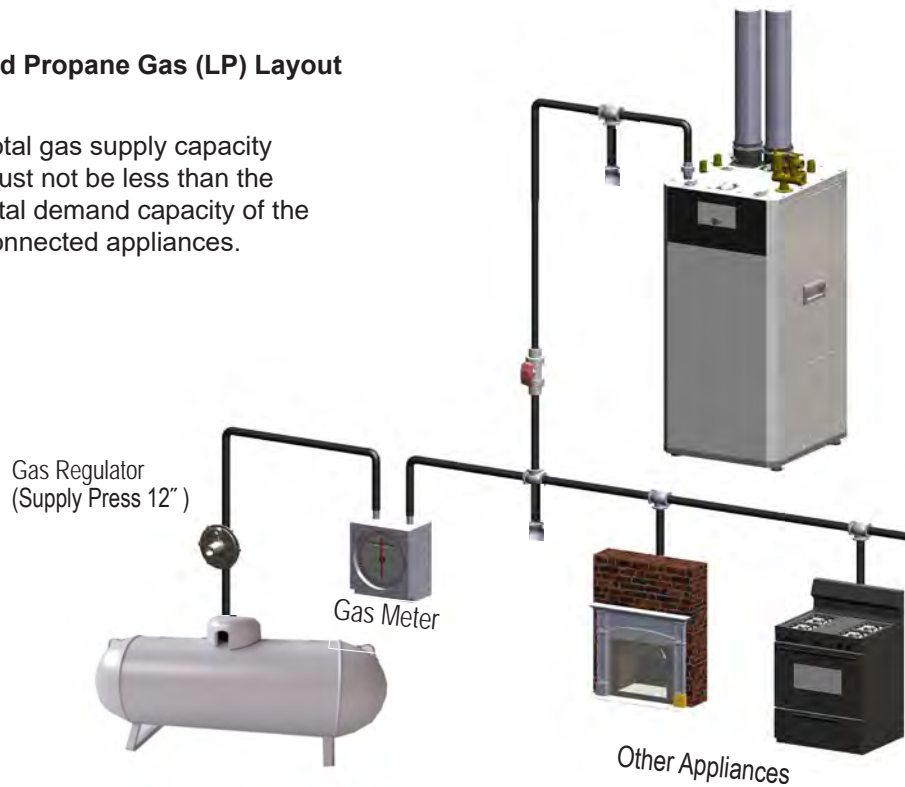

- The combination boiler must be installed downstream of the gas meter for adequate gas supply.
- The gas piping must not be less than **3/4" female NPT** on FTCTF199 models.

4.12 Gas Supply Pressure

Refer to the illustration.

Inlet Gas Pressure Port

Gas Outlet / Manifold Pressure Port

Offset Adjustment.

Do Not Adjust without using a combustion analyzer to verify adjustment. Adjust ONLY when in MIN Fire and when using a combustion analyser. See Section 4.13 for step by step details.

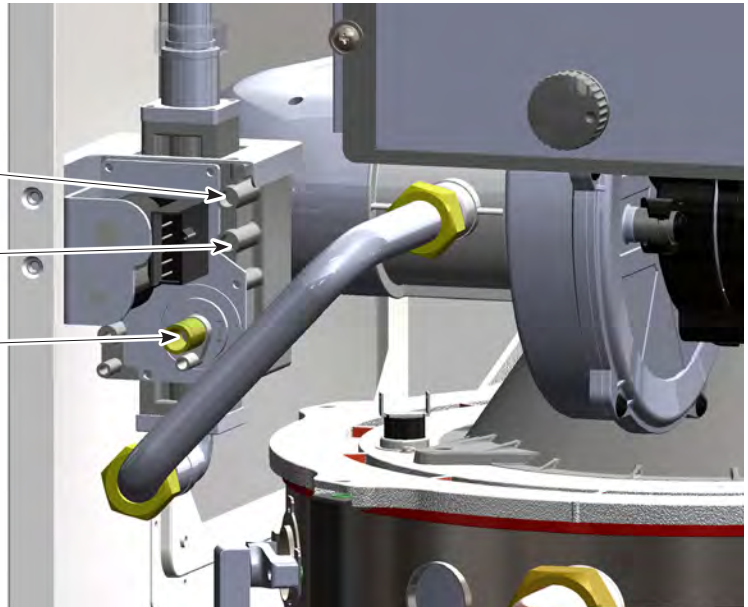

- The Maximum and Minimum gas line pressures must be at Max Fire operation.

LP Gas		Natural Gas	
Maximum Pressure	13.0" WC	Maximum Pressure	10.5" WC
Minimum Pressure	8.0" WC	Minimum Pressure	3.5" WC

Table 9. Gas Supply Pressures

CAUTION

- The appliance and its individual shut-off valve must be disconnected from the gas supply piping system during any pressure testing of the system at test pressures in excess of 1/2 psi (3.5 kPa).
- Loosen the pressure port screws before you check the gas inlet pressure.

4.13 Adjusting Combustion

1. Remove the front cover by opening the two clips on the top of the boiler front cover - tilt forward and lift the cover off.
 2. Turn ON the GAS and WATER supply to the FT.
 3. Turn ON the FT.
 4. Ensure your FT is set for the correct altitude. The default setting is for altitudes of 0~1,999 ft above sea level. If your FT floor is installed at an altitude of 2,000 ft, or greater the correct altitude setting should be set according to Section 4.13 of the FT Install and Operating Manual (Floor) before you continuing tuning this unit.
 5. Check gas inlet pressure at inlet pressure port. (See previous page).
 6. Establish a call for heat. You may need to disconnect the outdoor reset if you are making this gas conversion during warm weather.
 7. Connect a manometer to the manifold pressure port. For dual port manometers, use the positive pressure side. Check for proper manifold gas pressure. Refer to Table 10.
 8. Setup your combustion analyser and place the sensor into the combustion test port
 9. Per Table B in Section 4.15. for Max Fire change dip switch 6 to ON. The unit will cycle up to MAX fire.
 10. WAIT for your combustion analyser to stabilize. This may take up to 3 minutes depending on your combustion analyser. Then check the CO₂ measurement for MAX Fire. Refer to Table 10 for acceptable MAX fire combustion readings Do NOT attempt to adjust CO₂ at MAX Fire. ONLY adjust CO₂ in MIN Fire operation.
 11. For MIN Fire, change dip switch 6 to OFF and 7 to ON. The unit will cycle down to MIN Fire.
- Note:** When in Low Fire the burner should remain on. If the flame dies out after a few seconds while in Low Fire the gas input to the burner is too lean and will need to be increased slightly by using the offset adjustment. Turn the offset adjustment 1/8" clockwise and allow burner to cycle. Only adjust clockwise until the burner is able to remain lit. Once stable on Low Fire continue onto Step 12.
12. WAIT for your combustion analyser to stabilize. Then check the CO₂ measurement for MIN fire. Refer to Table 10 for acceptable MIN fire combustion readings
 13. Open the Gas Valve Adjustment Port by removing the cap screw with a # T15 wrench.
 14. Then use the # T15 wrench to make a minor adjustment (1/8 turn) to either increase or decrease CO₂. See 4.12 on page 36.
 15. It may be necessary to go back and forth between HI Fire and LOW Fire several times (and adjusting only at LOW Fire), before CO₂ at both are within acceptable levels. Be sure to put the adjustment port cap screw back onto the valve when done.
 16. Once the CO₂ and manifold pressure measurements for both MIN and MAX Fire are acceptable per Table 10, set DIP switches 6 and 7 to the OFF position for Nominal Fire (normal operation).
 17. Remove your combustion analyser from the Test Port and be sure to thread the Test Port plug back into position.
 18. Re-connect outdoor reset if it was disconnected, put the boiler cover back on and secure the clips that hold the cover in place.

Standard Factory Setting is for MAX Fire. 9.0% CO₂ @ 0-2,000 ft altitude (Natural Gas).

WARNING

Installer is required to verify combustion settings as part of the installation process.

CO ₂ value		Natural Gas (NG)		Propane Gas (LP)	
		2" VENT	3" VENT	2" VENT	3" VENT
FTCF199 (all altitudes)	MAX FIRE	8.5 - 10.5%		9.5 - 11%	
	MIN FIRE	8 - 10%		9 - 10.5%	

Table 10. CO₂ Values

Adjusting Combustion (continued)

Manifold Pressure		Natural Gas		Liquid Propane	
		2" VENT	3" VENT	2" VENT	3" VENT
FTCF199	Max Fire	-0.129" WC	-0.314" WC	-0.169" WC	-0.173" WC
	Min Fire	-0.015" WC	-0.015" WC	-0.015" WC	-0.015" WC



Table 11. Manifold Pressures

Note: Values in the range of -.001 to -.35 inches of WC are indicative of proper set-up. If your values are outside this range, call technical support.

4.14 High Altitude Installations. 2,000' to 10,000'

The FT is shipped with a default factory setting for installation at an altitude of 0 to 2000' (approx). For maximum efficiencies at higher altitudes (2,000' to 10,000'), the FT Boiler has an adjustment in the Installer Parameters Mode.

Follow these instructions if your installation is at 2,000' - 10,000'.

1. With the Power  turned OFF, press the 'Modes button'  for 5 seconds to get into the Installer Parameters Mode.
2. Turn the dial (E) until '**28:HA**' appears.
3. Press the dial (E).
4. Select the proper high altitude value by turning the dial.

#	Altitude of Installation
0 - 2	0 - 2,000 ft (0 - 609 m)
2 - 5	2,000 - 5,000 ft (609 - 1,522 m)
5 - 8	5,000 - 8,000 ft (1,522 - 2,436 m)
8 - 10	8,000 - 10,000 ft (2,436 - 3,045 m)

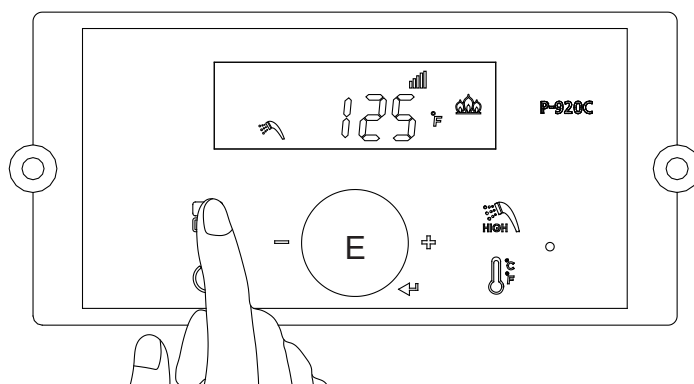

Refer to table.

5. Press the dial again (E) to save the setting.
6. Press the 'Modes button'  and the display will turn off.
7. Push the power button on the display to turn the boiler back on.

4.15 Natural Gas to Propane Conversion

The FT floor standing, condensing boiler is configured for Natural Gas (NG) from the factory. A Propane Conversion Kit is included with every FT. The gas conversion kit will show you how to convert your FT boiler to propane gas. If your FT does not have the bag containing the conversion kit, a replacement kit can be obtained. Contact the manufacturer and request a replacement conversion kit.

NOTICE

If your installation altitude is greater than 2000ft, check that the “High Altitude” Installer setting has been adjusted to suit your installation altitude. See section 4.14.

WARNING

This gas conversion kit shall be installed by a qualified service agency in accordance with the manufacturer’s instructions and all applicable codes and requirements of the authority having jurisdiction. The information in these instructions must be followed to minimize the risk of fire or explosion or to prevent property damage, personal injury or death. The qualified service agency is responsible for the proper installation of this kit. The installation is not proper and complete until the operation of the converted appliance is checked as specified in the manufacturer’s instructions supplied with the kit. Installation must conform to local codes and the latest edition of the National Fuel Gas Code, ANSI Z223.1 and CAN-B149.1. Failure to follow instructions could result in serious injury or property damage. The qualified agency performing this work assumes responsibility for gas conversion.

CAUTION

This boiler has already been set to burn natural gas, but can be converted to burn LP gas. Before placing the combination boiler into operation, verify that the proper type of gas is supplied to your combination boiler.



1. Open 2 toggle latch clamps fixed to the upper case of the product. Remove the front door from the product by lifting it upwards while tilting it by about 30°.
2. Turn OFF the FT. The ON / OFF button is located behind the front cover on the left front side of the appliance.
3. Turn OFF the GAS and WATER supply to the FT (valves are located on the plumbing pipes.)
4. Locate the Gas Inlet Pipe at the top left of the unit as shown in Figure A, and loosen the Brass Fittings at both ends of the Gas Inlet Pipe. See Figure B.
5. Completely unthread the brass fitting on the blower end of the Gas Inlet Pipe and then carefully swing the Gas Inlet Pipe to the left or right, just enough so that it is out of the way. See Figure B.
6. Remove the existing natural gas nozzle or orifice. If your unit is a 199, note that the flat side of the orifice is towards the blower. Save the packing for re-use. See Figure C.

Model	Natural Gas (NG) part #	Propane Gas (LP) part #	Orifices
FTCF 199	FT1780	FT1802	
	Natural Gas 8.3mm	Liquid Propane Gas 6.35mm	

Table A Gas Conversion Parts

4.15 Natural Gas to Propane Conversion (cont)

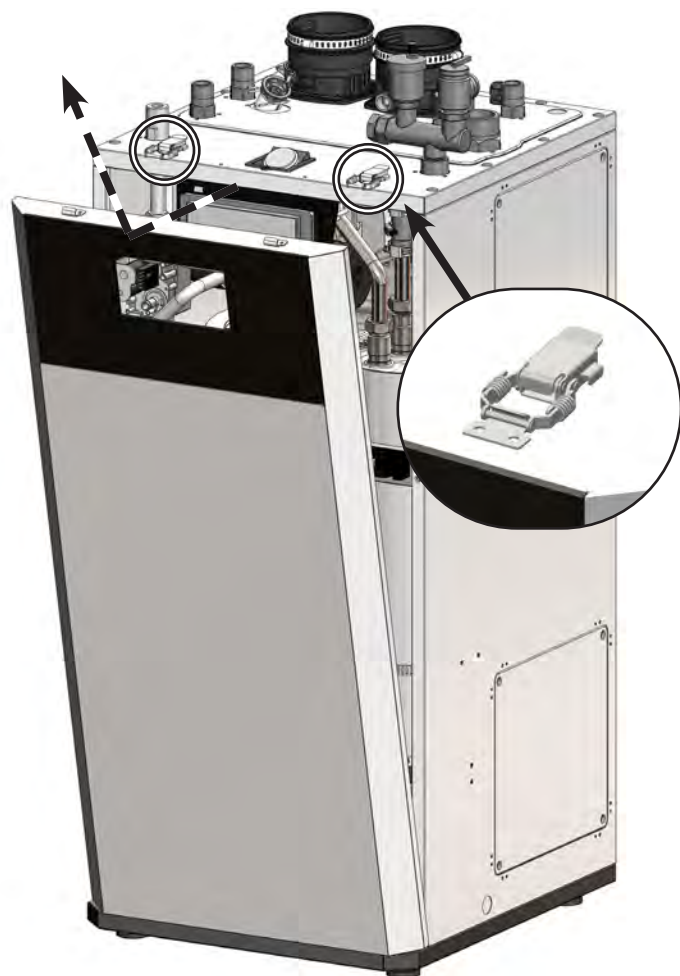

Figure A

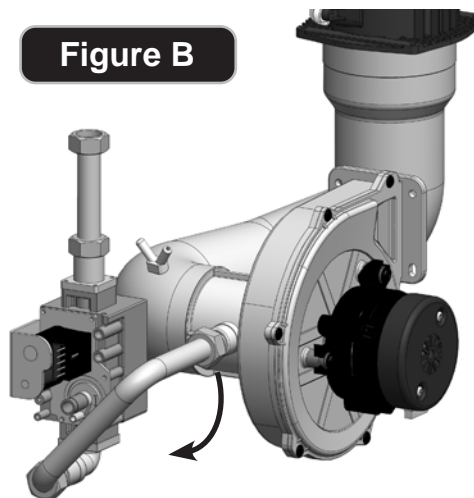

Figure B

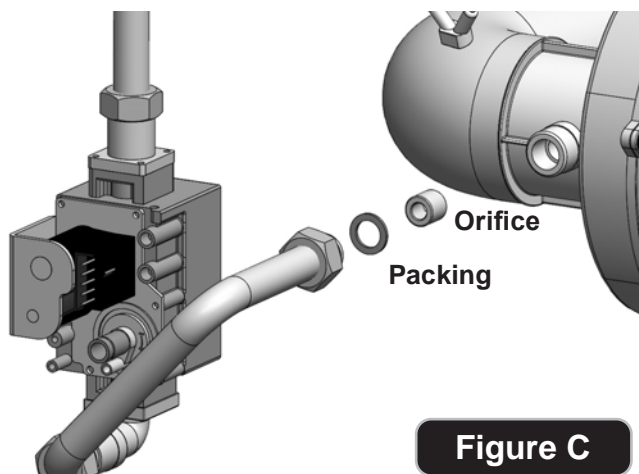

Figure C

This conversion shall be installed by a qualified service agency in accordance with the manufacturer's instructions and all applicable codes and requirements of the authority having jurisdiction. If the information in these instructions is not followed exactly, a fire, an explosion or production of carbon monoxide may result causing property damage, personal injury or loss of life. The qualified service agency is responsible for the proper and complete installation of this kit. The installation is not proper and complete until the operation of the converted appliance is checked as specified in the manufacturer's instruction supplied with the kit. Installation must conform to local codes and the latest edition of the National Fuel Gas Code, ANSI Z223.1 and CAN-B149.1. Failure to follow instructions could result in serious injury or property damage. The qualified agency performing this work assumes responsibility for gas conversion.



Ce conversion doit être installé par un organisme de service conformément aux instructions du fabricant et tous les codes et les exigences de l'autorité compétente. Si les informations contenues dans ces instructions n'est pas suivi à la lettre, un incendie, une explosion ou de la production de monoxyde de carbone mais résultat causant des dommages matériels, des blessures ou des pertes de vie. Le service est responsable pour la bonne et complète l'installation de ce kit. L'installation n'est pas correcte et complète jusqu'à ce que le fonctionnement de l'appareil converti est vérifiée comme spécifié dans le manuel d'instruction fourni avec le kit. L'installation doit être conforme aux codes locaux et la dernière édition du National Code de gaz combustible, ANSI Z223.1 et peut-B149.1. Non-respect des instructions peut entraîner des blessures graves ou des dommages matériels. L'organisme qualifié effectuant ce travail suppose la responsabilité de conversion au gaz.

4.15 Natural Gas to Propane Conversion (continued)

Shown is a Model 199 Natural Gas with 3" Venting.

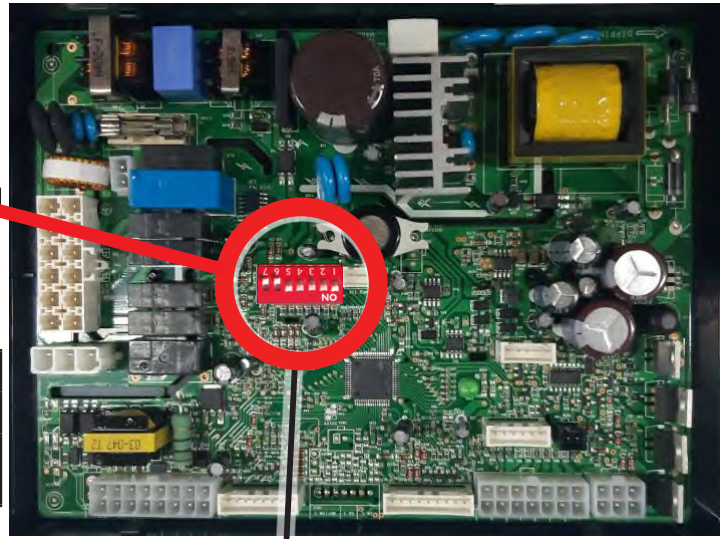

7*	6*	5	4	3	2	1
OFF	OFF	LP Gas	2" Vent			
Low Fire	High Fire	Natural Gas	3" Vent	FACTORY SET		

Table B Dip Switch Settings

*Dip Switches #7 and #6 are Maximum and Minimum fire test Switches which are used only when setting up combustion (See Section 4.13) These Switches should only be in the ON position during either High or Low fire Testing. When finished testing, ensure both of these switches are in the OFF position.

Dip Switches #1, 2 and 3 are Set at the factory and should not need adjusting. For Reference the correct positions of these three switches are as follows:
 Model FTCF199 : All three dipswitches should be in the "down"/ ON position. As shown above.

7. Install the new LP (propane) orifice. Re-use the existing gasket. Install the LP orifice with its identifying mark facing inward.
8. Return the Gas Inlet Pipe to its original position and tighten both brass fittings.
9. Per Table B, set DIP Switch 5 to OFF for LP Propane.
10. Turn ON the GAS and WATER supply to the FT
11. Now start the unit and adjust combustion as described in Section 4.12
12. Upon completion of set up, write in the correct Conversion Date and the Technicians Name to the included gas conversion sticker. See Figure F. Then apply that sticker adjacent to the rating plate.

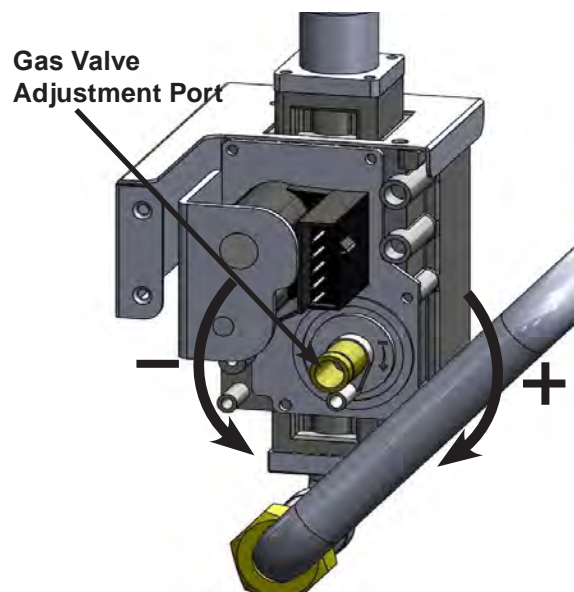

Figure E

4.15 Natural Gas to Propane Conversion (continued)

NOTE: Installer is required to verify combustion settings as part of the installation process. CO should not exceed 200 ppm.

CO ₂ value		Natural Gas (NG)		Propane Gas (LP)	
		2" VENT	3" VENT	2" VENT	3" VENT
FTCF199 (all altitudes)	MAX FIRE	8.5 - 10.5%		9.5 - 11%	
	MIN FIRE	8 - 10%		9 - 10.5 %	

Manifold Pressure		Natural Gas (NG)		Propane Gas (LP)	
		2" VENT	3" VENT	2" VENT	3" VENT
FTCF 199	MAX FIRE	-0.129"WC	-0.314"WC	-0.169"WC	-0.173"WC
	MIN FIRE	-0.015"WC	-0.015"WC	-0.015"WC	-0.015"WC

NOTE: Values in the range of -.001 to -.35 Inches WC are indicative of proper set-up. If your values are outside this range, call technical support.

This unit was converted on ___/___/___ to ___ gas with kit # _____ by _____ (name and company _____ accountable) _____ Cette unité a été converti ___/___/___ ten ___ gaz en utilisant le kit numéro _____ par _____ (nom et société _____ responsable) _____ _____

Figure F (Conversion label)

4.16 Plumbing Guidelines

4.16.1 External Plumbing and Water Connection Guidelines

- Ensure pipe material meets local codes and industry standards.
- The pipe end must be clean and free of debris.
- Do not apply torch heat within 12" of the top connections of the unit.
- The DHW inlet and outlet connections are 3/4". The Boiler supply and return connections are 1-1/2" NPT. System piping should be sized based on your design load and flow requirements. Refer to sections 4.16.4 through 4.16.8 for details.
- Isolation valves (shutoff valve) will be used.
- All piping should be insulated.

4.16.2 Applicable Backflow Preventer

- Apply a backflow preventer valve in the DHW supply inlet (water Inlet) to the unit as required by local codes.
- When using the combi boiler in a DHW recirculation application ensure that any backflow preventer or check valve is installed upstream of the cold water supply to the mixing valve. A DHW expansion tank is recommended. See DHW piping section 4.16.4

4.16.3 Diaphragm type Expansion tank and external LWCO mounting.

- The air in a diaphragm-type expansion tank is separated from the water by a flexible rubber membrane. When the tank is installed in and connected to the piping of the system, water enters the other side of the tank chamber and presses down on the diaphragm.
- You should always install an 'Automatic Air Vent on the top of the air separator to remove residual air from the system.
- Install the supplied brass adaptor, automatic air vent and relief valve on the top front right piping connection.
- If an external LWCO is required/ desired, the horizontal body of the brass adaptor fittings has a 3/4" connection for a remote LWCO.

- If no DHW recirc is installed, use the furnished 3/4" brass cap to close off the DHW recirc connection.

CAUTION

- The built-in LLH allows direct piping of system supply and return connections to their respective connections on top right side of the boiler. This greatly simplifies near boiler piping in a replacement application. Do NOT use primary/secondary piping!
- CH pipe size : 1 1/2"
- DHW pipe size : 3/4"

CAUTION

For guidelines in the use of Glycol Products. Please refer to Section 8.4 on page 84

CAUTION

Scalding Risk: Manufacturer requires the installation of the supplied anti-scald mixing valve at domestic hot water outlet (boiler location) to reduce potential for scalding. See Figure in Section 4.16.4 for DHW piping details. Check with local codes.



4.16.4 DHW Piping including DHW Recirculation Piping

The FTCTF199 boiler is capable of operating a DHW recirc pump along with receiving an input signal from either an DHW aquastat or 10 KOhm thermistor for sensing DHW temperature.

An anti-scald thermostatic mixing valve is included with each FTCTF199 and **MUST** be installed as outlined below. A thermal trap as shown must be installed.

The bold lined recirc piping is optional and would be field installed.

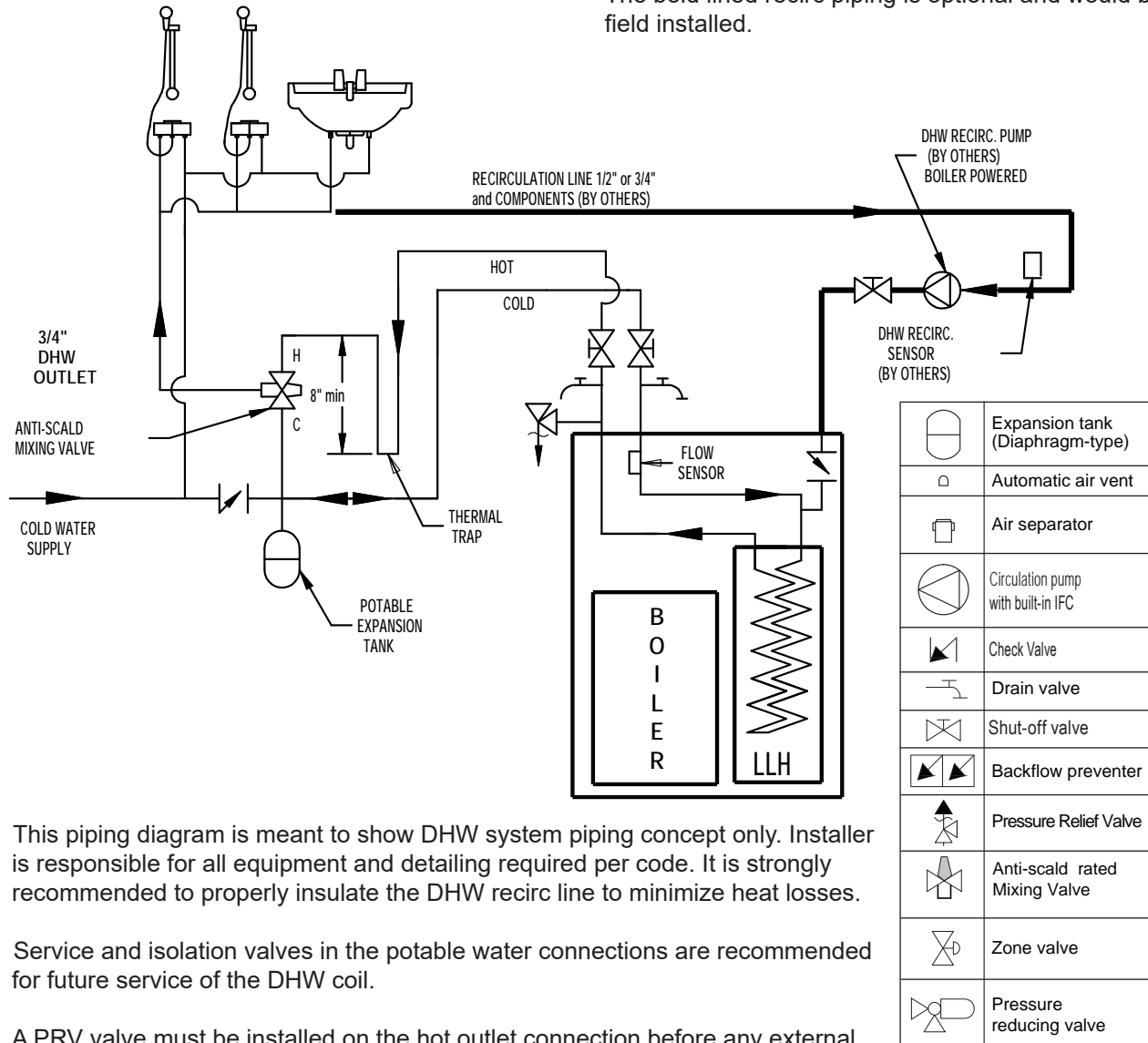

- 1) This piping diagram is meant to show DHW system piping concept only. Installer is responsible for all equipment and detailing required per code. It is strongly recommended to properly insulate the DHW recirc line to minimize heat losses.
- 2) Service and isolation valves in the potable water connections are recommended for future service of the DHW coil.
- 3) A PRV valve must be installed on the hot outlet connection before any external shut-offs. The discharge pipe must be piped within 6" to 12" of a nearby floor drain.
- 4) Note that the 3/4" recirculation connection has a built-in flow check installed within the first internal elbow of the 3/4" recirc line.
- 5) An optional potable water check valve and potable water thermal expansion tank is recommended after the last cold water draw and before the mixing valve cold tapping in case of a DHW recirculation loop. (As shown above).
- 6) Manufacturer requires the use of an anti-scald mixing valve at the domestic hot water outlet (boiler location) to reduce potential for scalding. An approved anti-scald valve is included in the accessory box. Check with local codes.

Wiring for DHW recirculation loop pump controlled by the FTCF boiler

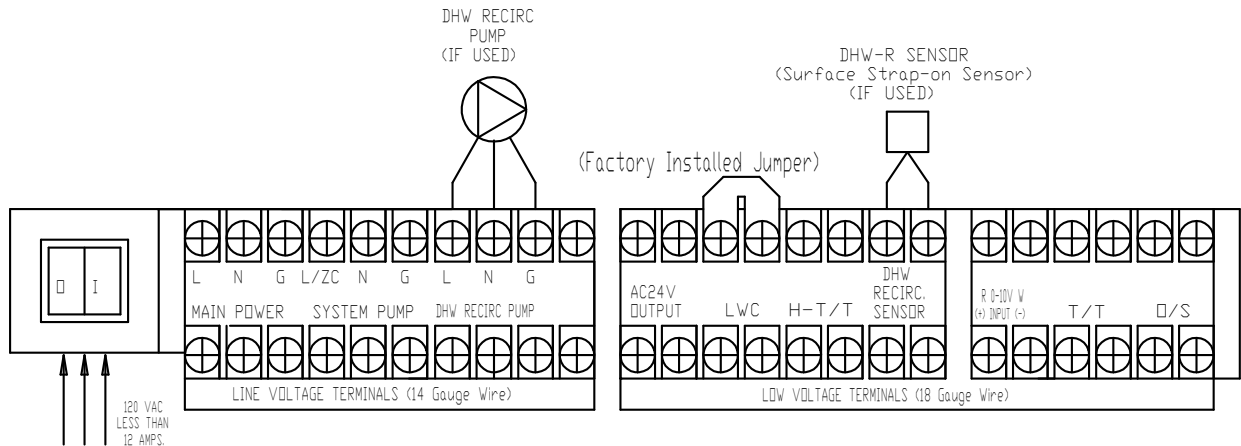

- 1) When using a DHW recirculation loop, install the DHW recirc sensor (Optional item: part no: FT1868) by strapping it on the recirculation line close to the boiler and insulate the assembly. Use 18 gauge wire and connect the DHW-R sensor to DHW recirc terminals.
- 2) The operation of the DHW recirc pump is programmed as per the Installer menu, section 5.8.
- 3) A dry contact aquastat can also be used for measuring the DHW recirc water temperature in lieu of the optional DHW recirc sensor by installing the aquastat into a dry well (not provided). Refer to section 5.8 for proper programming.
- 4) The FTCF boiler can also control a small recirc pump without DHW-R sensor or recirc aquastat. In this case the boiler will control the recirc pump operation based on parameters 32 and 33 in section 5.8 and cycle the recirc pump based on these parameter values.

Note: This space is intentionally left blank.

Plumbing Guidelines (continued)

4.16.5 Zoning with zone valves

- In a zone valve based system, there is one circulator pump and each heating zone has a zone valve which opens when the zone demands heat.
- Each thermostat is wired directly to the corresponding zone valve. Contacts in the zone valves provide a call for heat to the zone relay panel when the valve is opened.

Note: The signal back to the T/T terminals on the FT Floor boiler must be a dry contact. Do NOT send a 24 V signal to the FT Floor boiler.

Refer to section 4.16.4 for detailed DHW piping for the FT Floor Combi boiler.

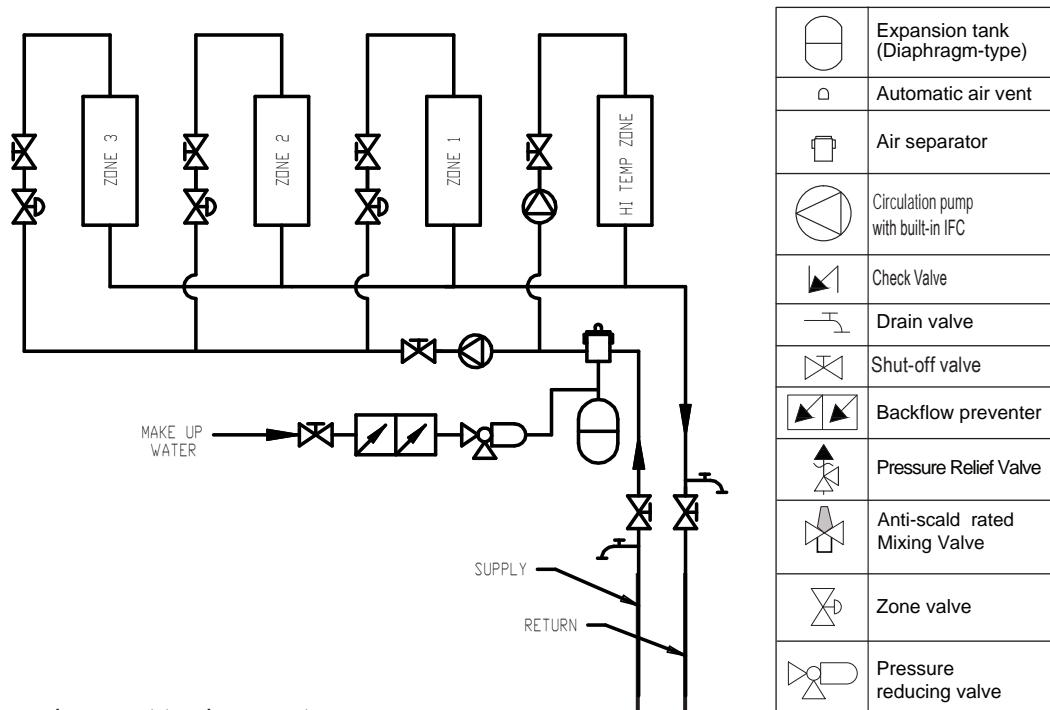

- 1) This piping diagram is meant to show system piping concept only. Installer is responsible for all equipment and detailing required by local codes.
- 2) The system return must be piped directly to the Boiler Return connection.
- 3) The system supply must be piped directly to the Boiler Supply connection.
- 4) The minimum pipe size of DHW piping should be 3/4" diameter.
- 5) Install a minimum of 12 diameters of straight pipe upstream of all circulators.
- 6) Manufacturer requires the use of an anti-scald mixing valve at domestic hot water outlet (boiler location) to reduce potential for scalding. An approved anti-scald valve is included in the accessory box. Check with local codes.

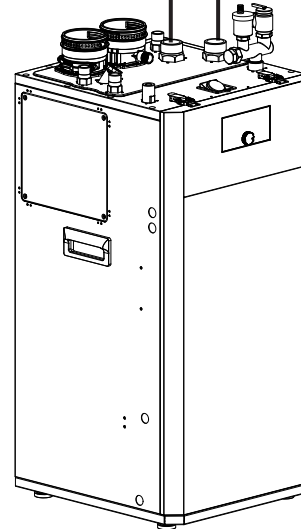

Wiring of zone valve system with an optional high temp “on demand” zone with dedicated pump.

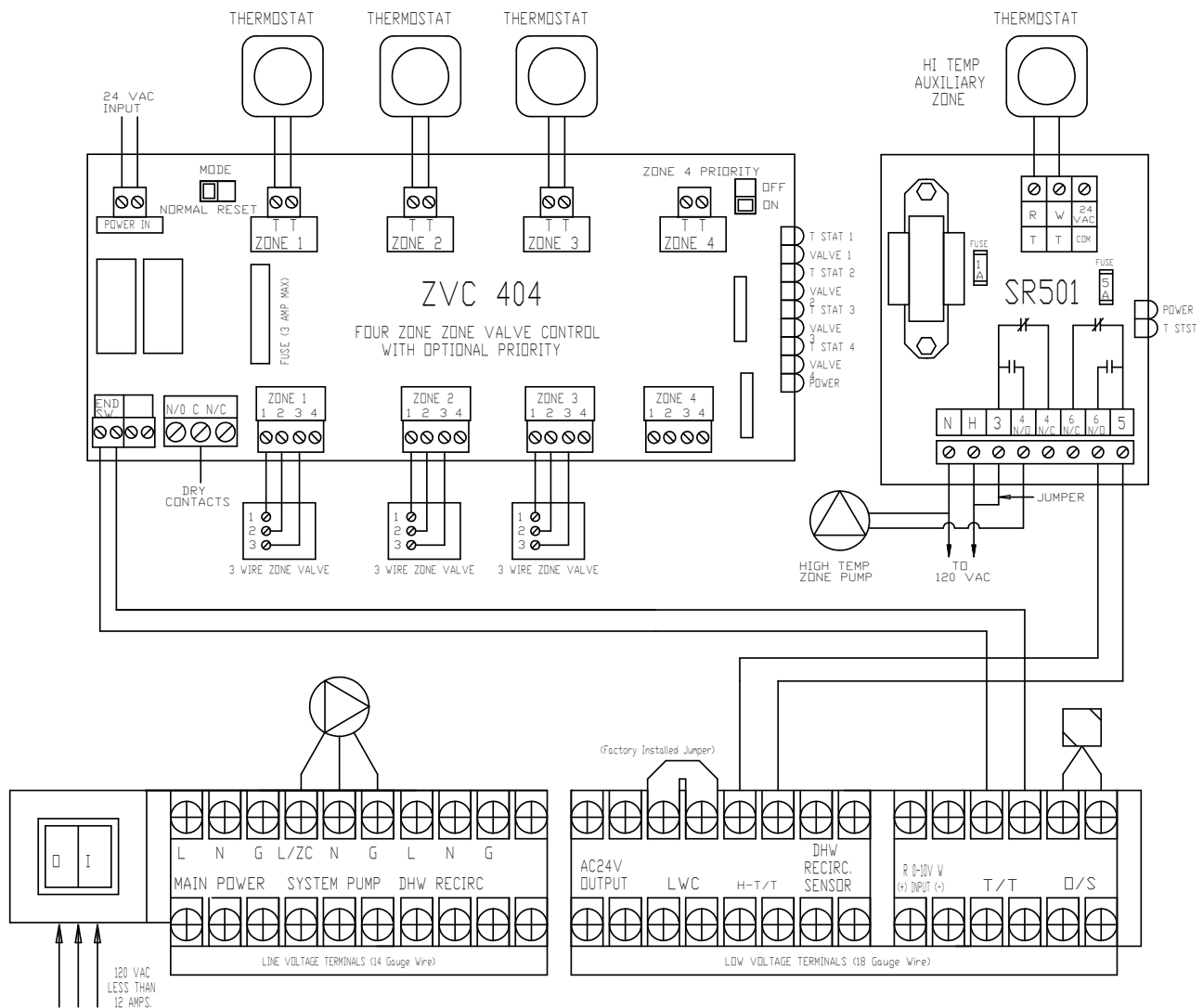













- 1) Taco ZVC 404 used for illustrative purposes; other, similar zone valve control panels can be used.
- 2) Connect the end switch of the zone valve panel back to the T/T terminals on the FTFCF boiler.
- 3) Connect the system pump for the zone valves to the System Pump terminals.
- 4) Connect the outdoor sensor (OS) to its terminals.
- 5) Do not bring 24 V back to the T/T or H-T/T terminals on the FTFCF boiler. Only a dry contact switch is allowed.
- 6) In case an "on-demand" high temperature zone is required, use a single pump relay and wire its pump and thermostat to this relay. The end switch is connected to the H-T/T terminals. A contact closure to H-T/T brings the boiler into a high temperature status, operates the boiler pump continually and maintains the LLH between 160 and 180 F.

Note: While H-T/T is calling, other zones will still be allowed to demand heat and will therefore receive high temperature supply water. Caution should be used with zones that could be damaged by high temperature supply water such as radiant underfloor zones. Zone mixing valves for these individual zones is strongly encouraged.

4.16.6 Zoning with a single pump

- 1) In a single zone system, an external zone pump is required and is wired directly back to the boiler to the system pump wiring terminals.
- 2) The zone thermostat (dry contract only) is wired back to the T-T connection on the low voltage terminal strip in the boiler.

Refer to section 4.15.4 for detailed DHW piping for the FT Floor Combi boiler.

	Expansion tank (Diaphragm-type)
	Automatic air vent
	Air separator
	Circulation pump with built-in IFC
	Check Valve
	Drain valve
	Shut-off valve
	Backflow preventer
	Pressure Relief Valve
	Anti-scald rated Mixing Valve
	Zone valve
	Pressure reducing valve

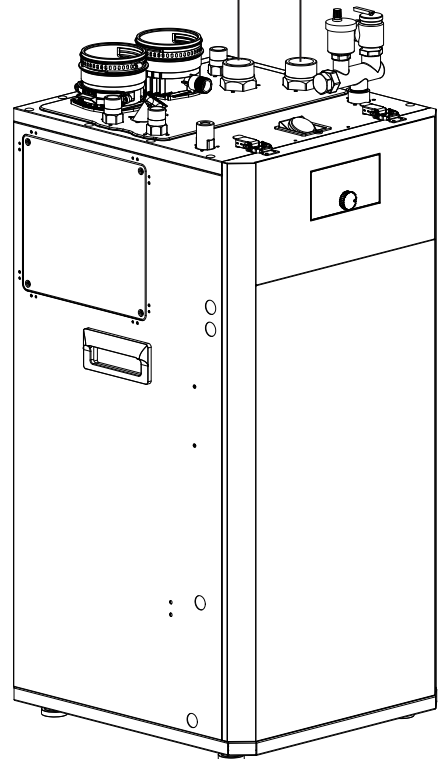
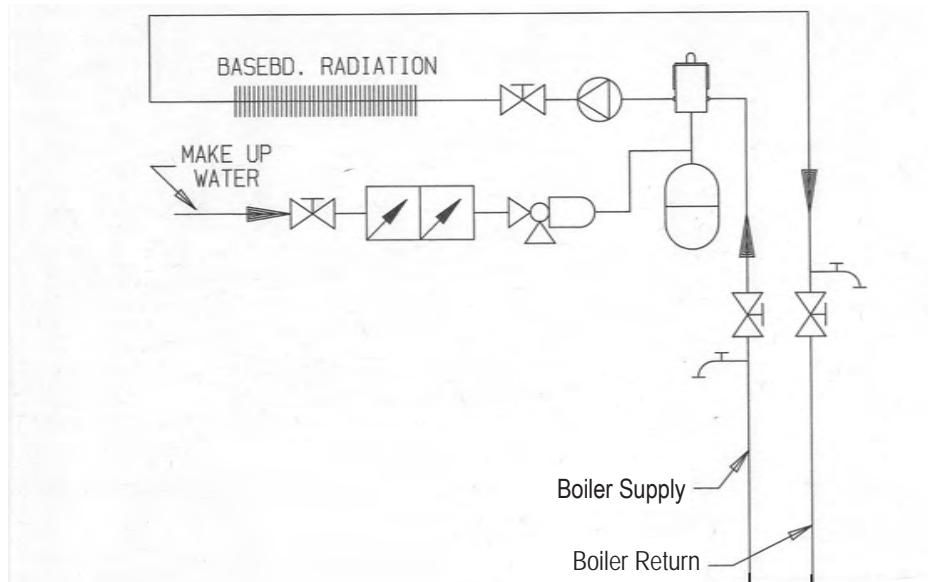

- 1) This piping diagram is meant to show system piping concept only. Installer is responsible for all equipment and detailing required by local codes.
- 2) The minimum pipe size of DHW piping should be 3/4" diameter.
- 3) Install a minimum of 12 diameters of straight pipe upstream of all circulators.
- 4) Manufacturer requires the use of an anti-scald mixing valve at domestic hot water outlet (boiler location) to reduce potential for scalding. An approved anti-scald valve is provided in the accessory box. Check with local codes.

Wiring of a single pump system.

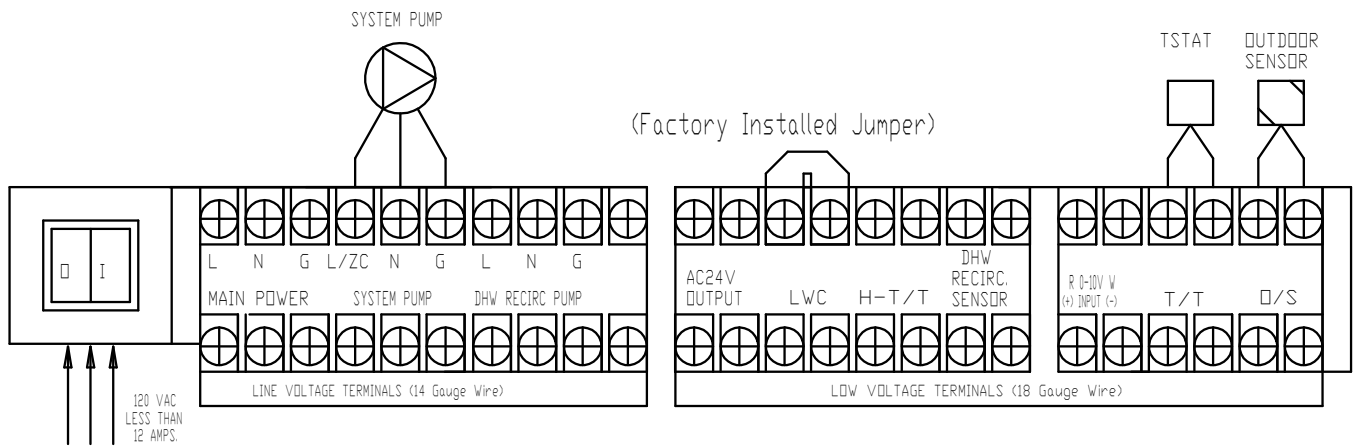

- 1) Do not bring 24 V to any terminals on the FTCF boiler. The room thermostat (dry contact only) connects back to the T/T terminals.
- 2) Install the outdoor sensor (OS) for outdoor reset operation.
- 3) Connect the system pump as shown above.

Note: This space is intentionally left blank.

4.16.7 Zoning with multiple pumps

- 1) In a pump based system, each heating zone has its own circulator pump which run when the zone demands heat.
- 2) Each zone thermostat goes to a Pump Relay Panel which controls the pumps. The dry contact end switch of the relay panel connects back to the T-T terminals on the FT boiler.

Refer to section 4.15.4 for detailed DHW piping for the FT Floor Combi boiler.

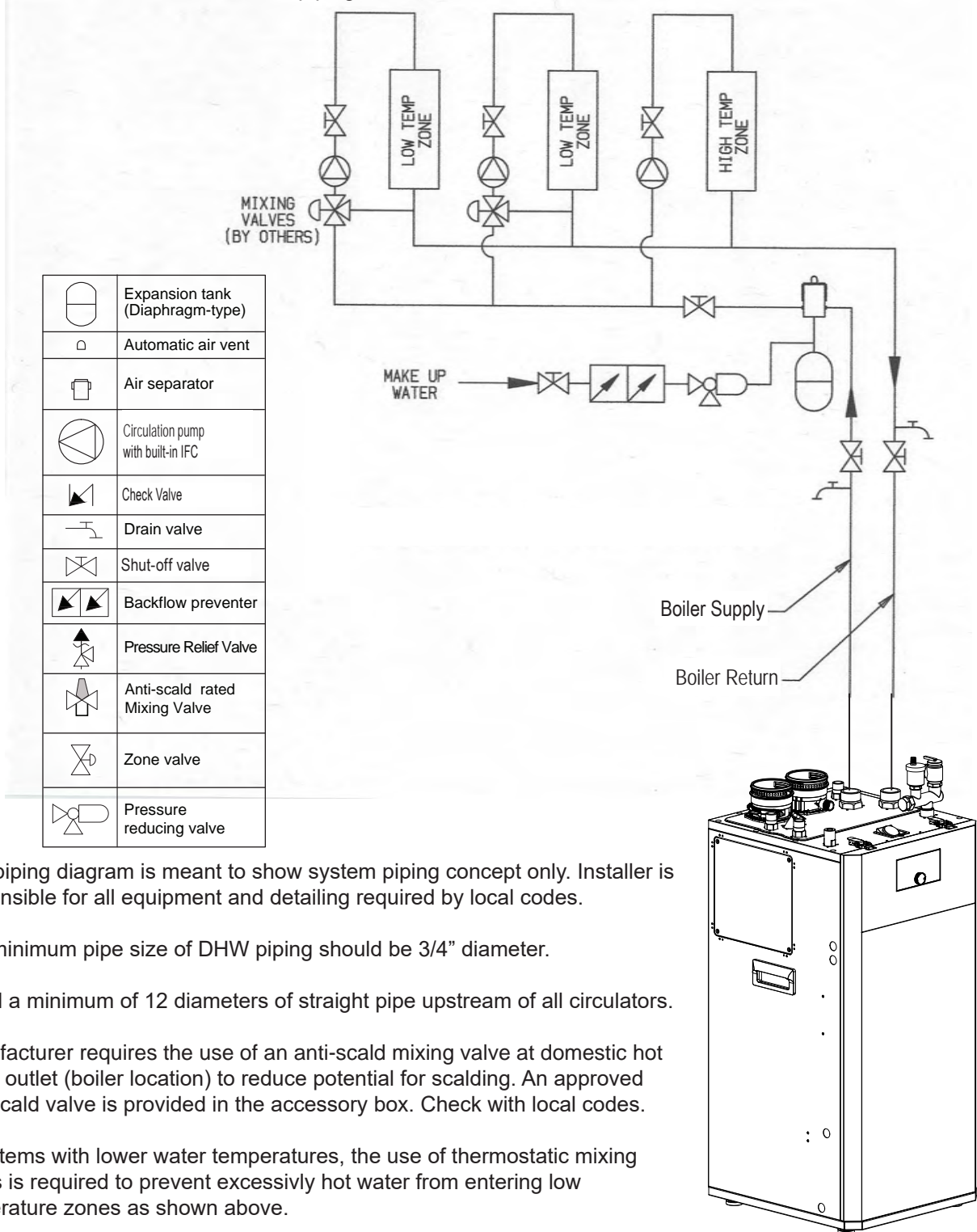

- 1) This piping diagram is meant to show system piping concept only. Installer is responsible for all equipment and detailing required by local codes.
- 2) The minimum pipe size of DHW piping should be 3/4" diameter.
- 3) Install a minimum of 12 diameters of straight pipe upstream of all circulators.
- 4) Manufacturer requires the use of an anti-scald mixing valve at domestic hot water outlet (boiler location) to reduce potential for scalding. An approved anti-scald valve is provided in the accessory box. Check with local codes.
- 5) In systems with lower water temperatures, the use of thermostatic mixing valves is required to prevent excessively hot water from entering low temperature zones as shown above.

Wiring of a multiple pump system.

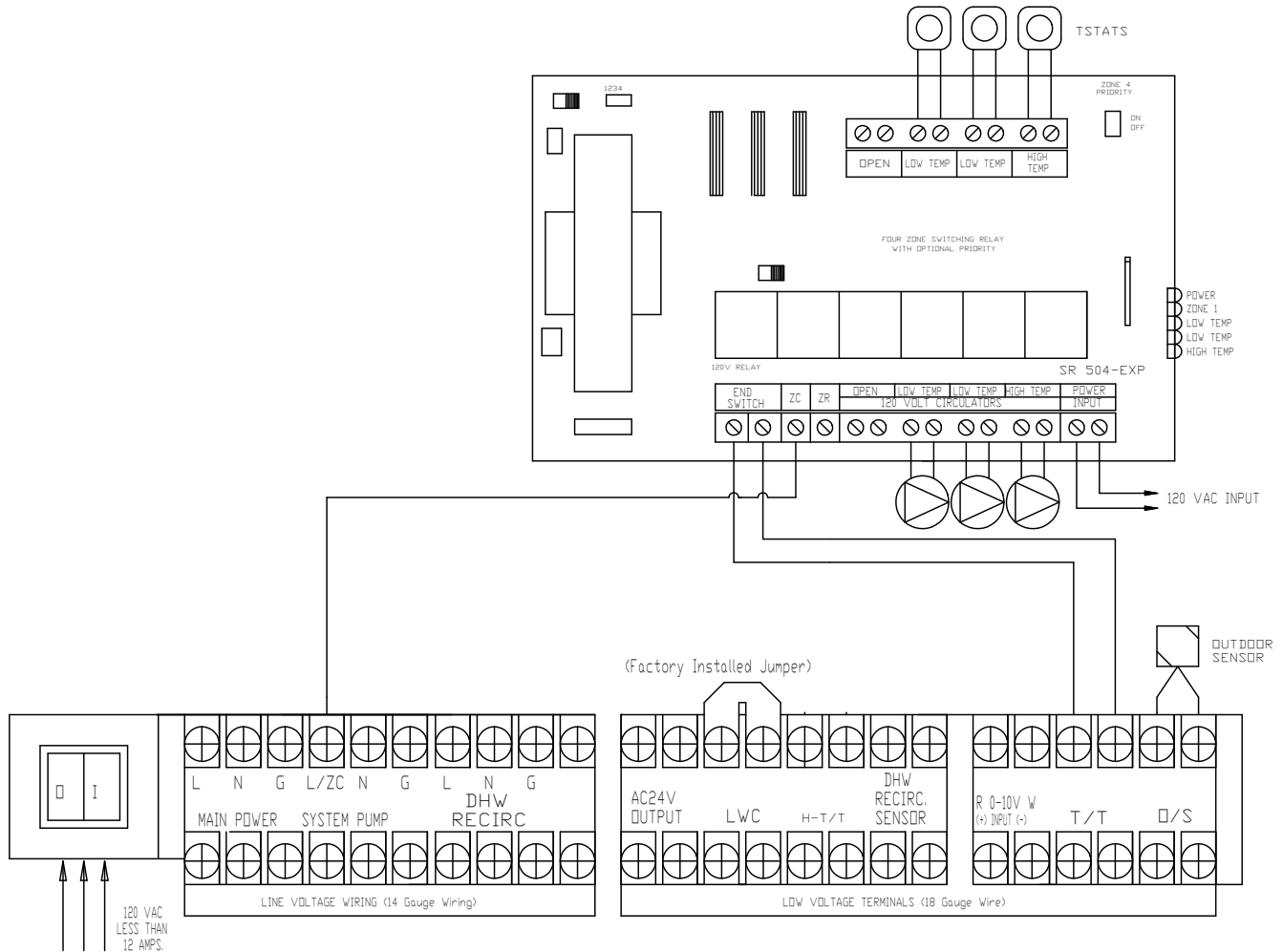

- 1) Use a multi-zone relay panel (Taco SR504-EXP shown) and connect all thermostats and zone pumps into this relay panel. Other, similar multi-zone relay panels can be used.
- 2) Do Not connect 24 V to either the T/T or H-T/T terminals. Only connect a dry contact closure back to these terminals.
- 3) Connect end switch of relay panel back to the T/T terminals of the FTCF boiler.
- 4) Remove the internal jumper between ZC and ZR terminals of the relay panel and run a 14 gauge wire from L/ZC on the terminals of the FTCF boiler back to the ZC terminal on the relay panel. When using another relay panel, contact technical support for proper installation.
- 5) Install the OS (outdoor sensor) to the O/S terminals.

4.18 Pressure Relief Valve

- External pressure relief valves must be installed. Observe the following. Failure to comply with the guidelines on installing the pressure relief valve and discharge piping can result in personal injury, death or substantial property damage.

⚠ WARNING

Do not operate this appliance before the pressure relief valve supplied is installed with sufficient relieving capacity in accordance with the ASME Rating Plate on the boiler.

- A special brass adaptor, air eliminator and relief valve are supplied in an accessory box. Install this fitting on the right front connection as shown here.
- This safety relief valve (30 psi) is shipped loose for field installation.
- Install the air eliminator and relief valve as shown.
- For safety, the relief valve(s) must be installed into its designated location and not be removed or plugged. Failure to comply with the guidelines on installing the pressure relief valves and discharge piping can result in personal injury, death or substantial property damage.
- Direct the discharge piping of the pressure relief valve to a nearby floor drain so that hot water will not splash on anyone or any nearby equipment. Attach the hard piped copper discharge line to the pressure relief valve and run the end of the line within 6-12" (150 - 300mm) of the floor.
- A separate external LWCO can be installed by removing the 3/4" cap on the brass adaptor to install the LWCO.

⚠ WARNING

DO NOT install a CH pipe line relief valve with a pressure higher than 30 psi and a DHW pressure relief valve with a pressure rating above 150 psi. This is the maximum allowable relief valve setting for the combination boiler.

- Test the operation of the valve after filling and pressurizing system by lifting the lever. Make sure the valve discharges freely. If the valve fails to operate correctly, replace it with a new relief valve. Ensure that the discharge capacity of the pressure relief valve is equal to or greater than the maximum input rating of the combination boiler.

- Ensure that the maximum BTU/H rating on the pressure relief valve is equal to or greater than the maximum input BTU/H rating of the combination boiler.
- Pressure Relief Valve must be installed on the provided CH Pressure Relief valve tapping at the top of the Combi (CH supply line: maximum 30 psi, DHW outlet line : maximum 150 psi). No other valves should be placed between the pressure relief valve and the appliance.
- Place a 150 psi PRV on DHW outlet piping as close to the unit as possible.
- This appliance has a high-temperature shut off switch built in as a standard safety feature. Therefore a "pressure only" relief valve is required.

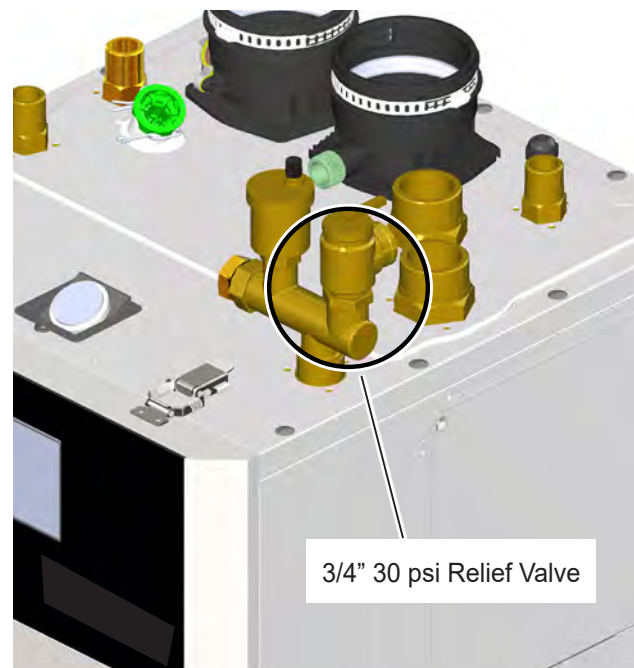

4.18 Disposal of Condensate

- High efficiency gas condensing boilers create condensation when operating. Condensation is acidic with a pH ranging from 4 to 5.
- Attach the supplied condensate drain hose to the installed condensate trap. Make sure to attach the 1/8" air vent tube and secure this 6" long hose to a bracket so it will not spill condensate. Follow your local code with regards to the disposal of condensation.

One of 3 disposal methods must be followed

- 1. to a floor drain**
- 2. Combination neutralizer and condensate pump kit (optional kit available from manufacturer)**
- 3. to a condensate pump (field supplied)**

- If a neutralizer is installed, periodic replacement of the lime stone (or neutralizing agent) will be required. The rate of depletion of the lime stone varies upon usage of the boiler. During the first year of operation, please check the neutralizer every few months for depletion.
- Apply only corrosion-resistant materials for the condensate drain lines such as 1/2" PVC, CPVC, Polypropylene pipe or included plastic hose.
- In case of a closet installation, a combination neutralizer/pump (FT3007 kit) can be installed by removing the lower left access panel, an electrical outlet (Max amp rating: 2 Amp) is provided to power the condensate pump.
- Overall dimensions can not exceed 15-7/8" (L) x 5-7/16" (W) x 6-3/4" (H) in order to fit inside the boiler cabinet.

- If desired, a discharge 1/4" or 3/8" can be routed by removing yellow cap from the top right rear corner and routing the hose down to the condensate pump.
- Knock-out provisions are supplied in the lower left, rear or right hand side panels to rout the condensate to a nearby floor drain or externally placed condensate pump.
- Cut a small opening in the plastic grommet and pull the discharge hose through the opening for strain relief.
- When placing the FT3007 kit inside the cabinet, drill a 1/2" hole in the cover of the neutralizer section and secure the condensate hose coming from the trap to this cover. One can also use the soft plastic insert, shorten the condensate drain hose and carefully "thread" the hose into this insert and place it into its designation location of the FT3007 kit.

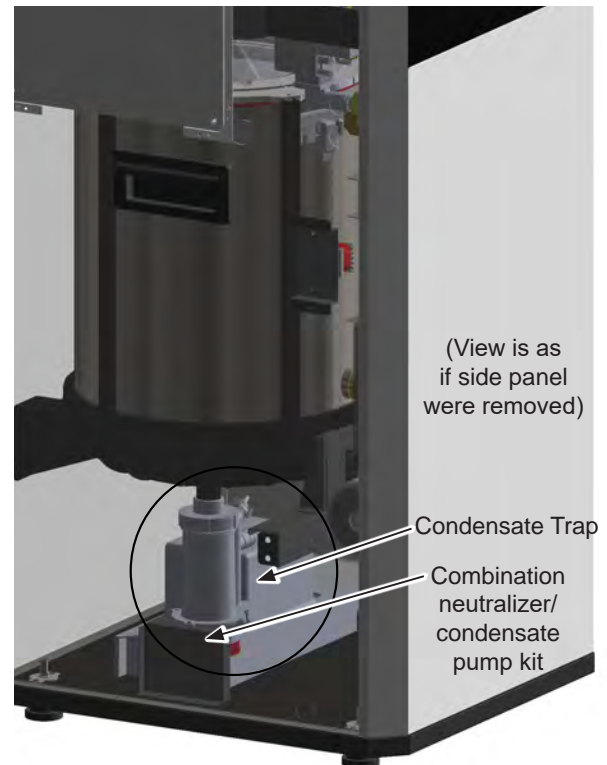

NOTICE

Category II & IV boilers must be installed with a means provided for the drainage of condensate.

AVIS

les chaudières de catégories II et IV doivent être installées avec un moyen de drainage du condensat.

CAUTION

Condensate is mildly acidic (pH=5), and may harm some floor drains and/or pipes, particularly those that are metal. Ensure that the drain, drainpipe, and anything that will come in contact with the condensate can withstand the acidity, or neutralize the condensate before disposal. **Damage caused by failure to install a neutralizer kit or to adequately treat condensate will not be the manufacturer's responsibility.**

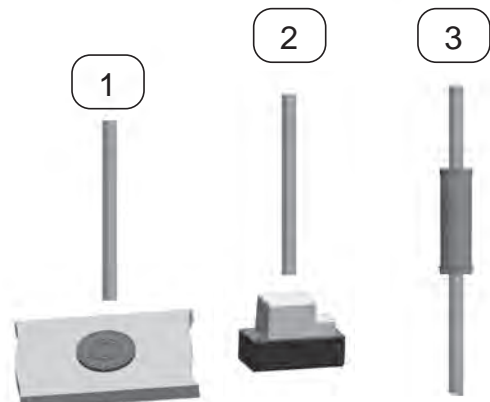

Various condensate disposal methods

4.19 DHW Flow Restrictor

Flow Restrictors are factory installed. Rated at 7.0 GPM for the model 199, this flow restrictor is white color.

To clean the flow restrictor and inlet water filter, perform the following steps:

1. Being sure that the unit is completely shut off and drained, locate the DHW inlet adapter on the top, close off water shut-off valves and drained.
2. Pull the two pins to release the DHW inlet filter. See Illustration. The flow restrictor is attached to the top of the filter assembly.
3. Have a towel handy to mop up any water.
4. Clean and reinstall the DHW inlet filter.
5. Re-insert the two pins.
6. Refill and restart your FT as per the Installation Instructions.

⚠ WARNING

If the appliance has been filled and operational, then the gas, water and power must be completely shut off, and the unit must be drained before proceeding with this instruction. See Section 8 of this installation book.

Failure to do so could result in substantial property damage, sever personal injury, or death.

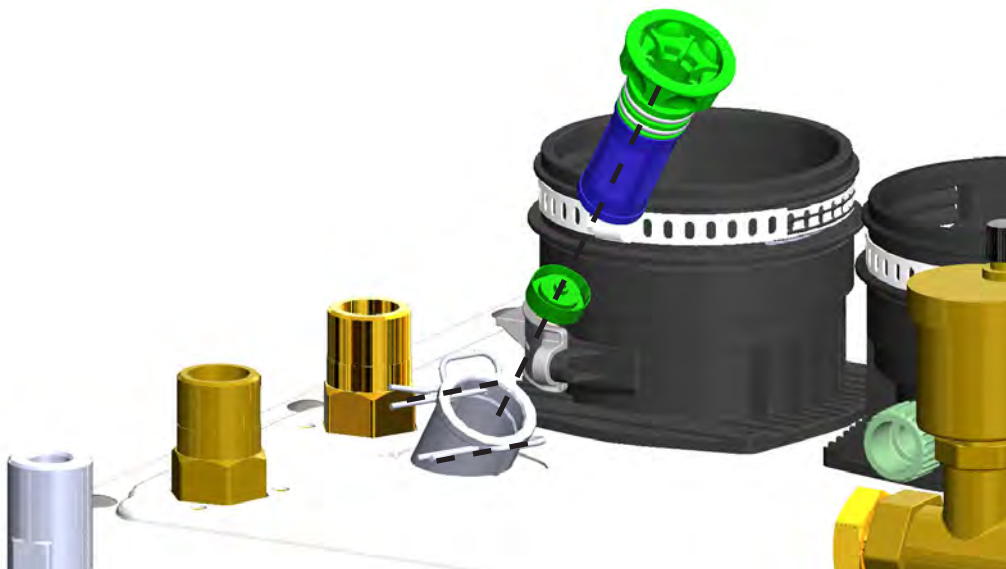
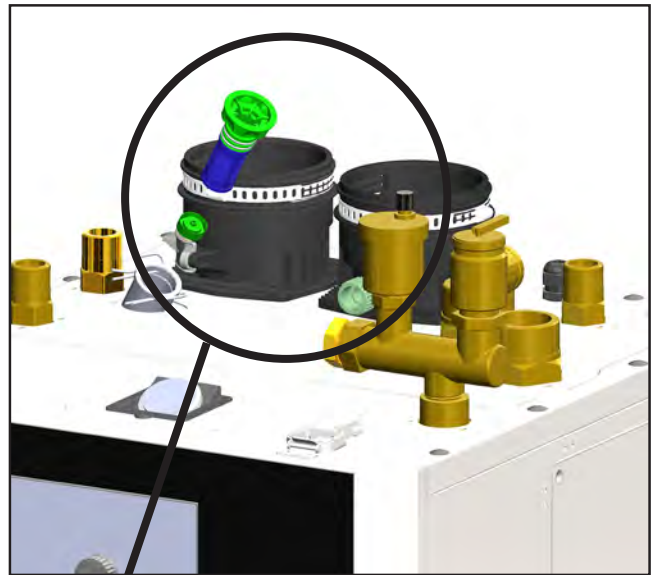

4.20 Electrical Wiring Connections

Field Wiring: Top of terminals

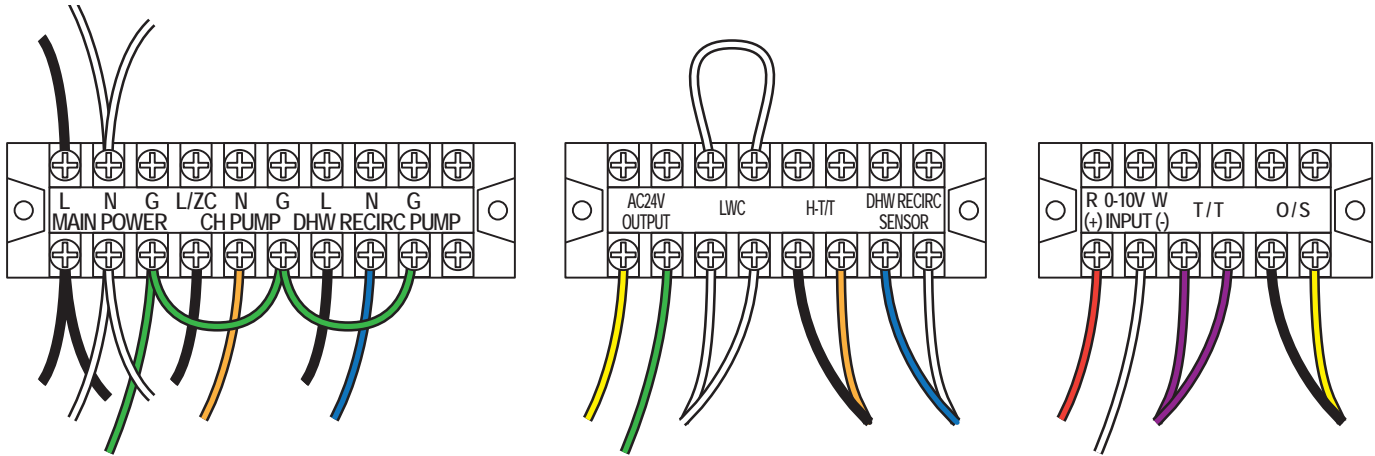

⚠ WARNING

Install wiring and electrically ground boiler in accordance with authority having jurisdiction or, in the absence of such requirements, follow the National Electrical Code, NFPA 70, and/or CSA C22.1 Electrical Code-Part 1 in Canada.

ELECTRICAL SHOCK HAZARD — For your safety, turn off electrical power supply at service entrance panel before making any electrical connections to avoid possible electric shock hazard. Failure to do so can cause severe personal injury or death.

- This appliance must be electrically grounded. Ensure the electrical receptacle that the combination boiler will be plugged into, is properly grounded; if wiring directly.
- It is permissible to remove the electrical plug and hard wire the appliance directly into appropriately sized electrical wiring, properly grounded.
- Do not attach the ground wire to either the gas or the water piping as plastic pipe or dielectric unions may isolate the Combination boiler electrically.
- The wiring diagrams contained in this manual are for reference purposes only.
- Refer to these diagrams and diagrams from external controls used with this appliance. Read, understand, and follow all wiring instructions.
- Do not disconnect the power supply when the unit is in normal operation. Damage caused by freezing is not covered under the warranty.
- Manual(Rocker) switch maximum allowable current for each circulator is 1.6 amps at 125VAC.
(Housing : Nylon #66 UL 94V-2 , Rocker : Nylon #66 UL 94V-2, Terminal : Copper Alloy)
- Terminal block (External power connector) : DFT-20A-10P (20 amps at 300VAC)

4.20 Electrical Wiring Connections (continued)

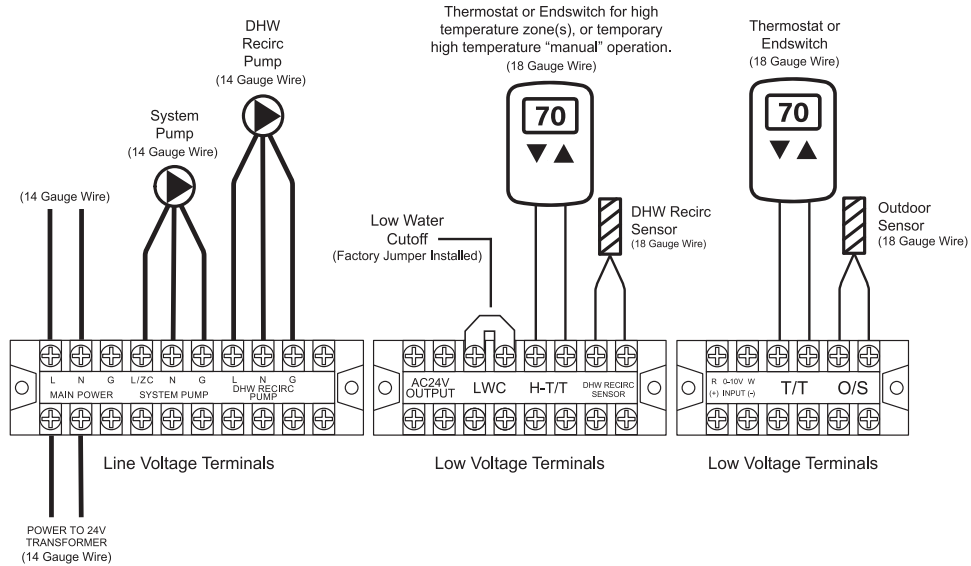

4.21 Dip Switches

Shown is a Model 199 Natural Gas with 3" Venting.



7*	6*	5	4	3	2	1
OFF	OFF	LP Gas	2" Vent			
Low Fire	High Fire	Natural Gas	3" Vent	FACTORY SET		

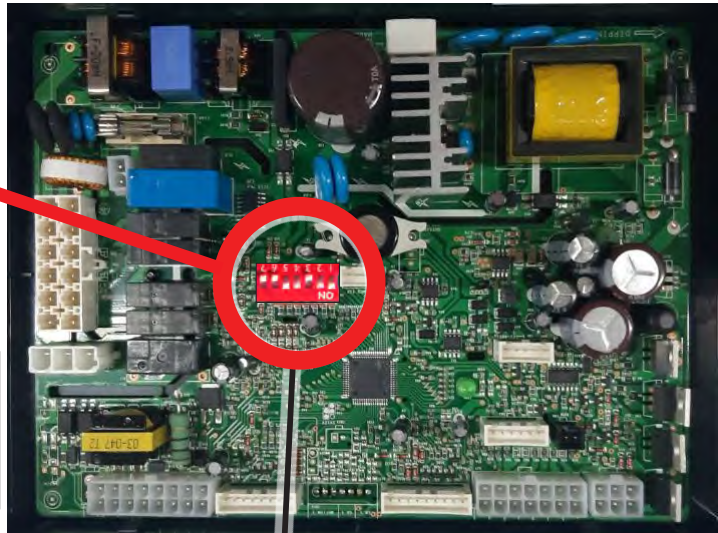

*Dip Switches #7 and #6 are Maximum and Minimum fire test Switches which are used only when setting up combustion (See Section 4.13). These switches should only be in the ON position during either High or Low fire testing. When finished testing, ensure both of these switches are in the OFF position.

Dip Switches #1, 2 and 3 are Set at the factory and should not need adjusting. For reference the correct positions of these three switches are as follows: Model FTCTF199: All three dipswitches should be in the "down"/ ON position (As shown above)

System Control Setting

Maximum flame detecting voltage	2.4V
Pre-purge time (Tp)	Maximum 10s, minimum 1s
Safety Time (igniting time) (Ts)	3s
Igniting interval time	10s
Post-purge time (Tip)	120S (1st : 60s + 2nd 60s)
Over-heating 1,2,3 protection detection time	<3s
Pump1 post circulating time (T1pv)	60s
Pump2 post circulating time (T1pv)	60s
High & Low Water Level detection time	<6s
High & Low Water Level Recover time	<6s

4.22 Control Board, Electrical Diagram

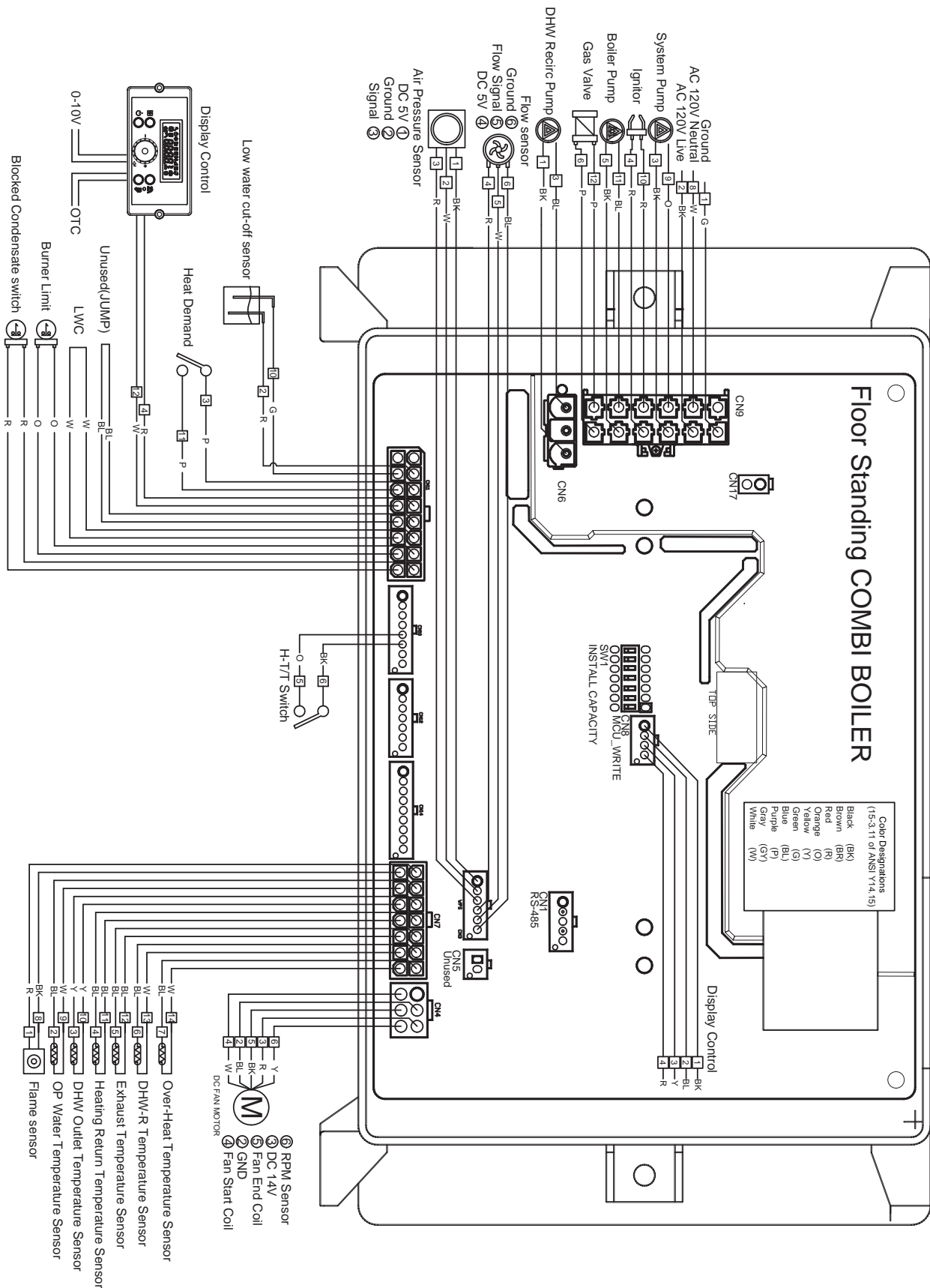

Control Board

4.23 Ladder Diagram

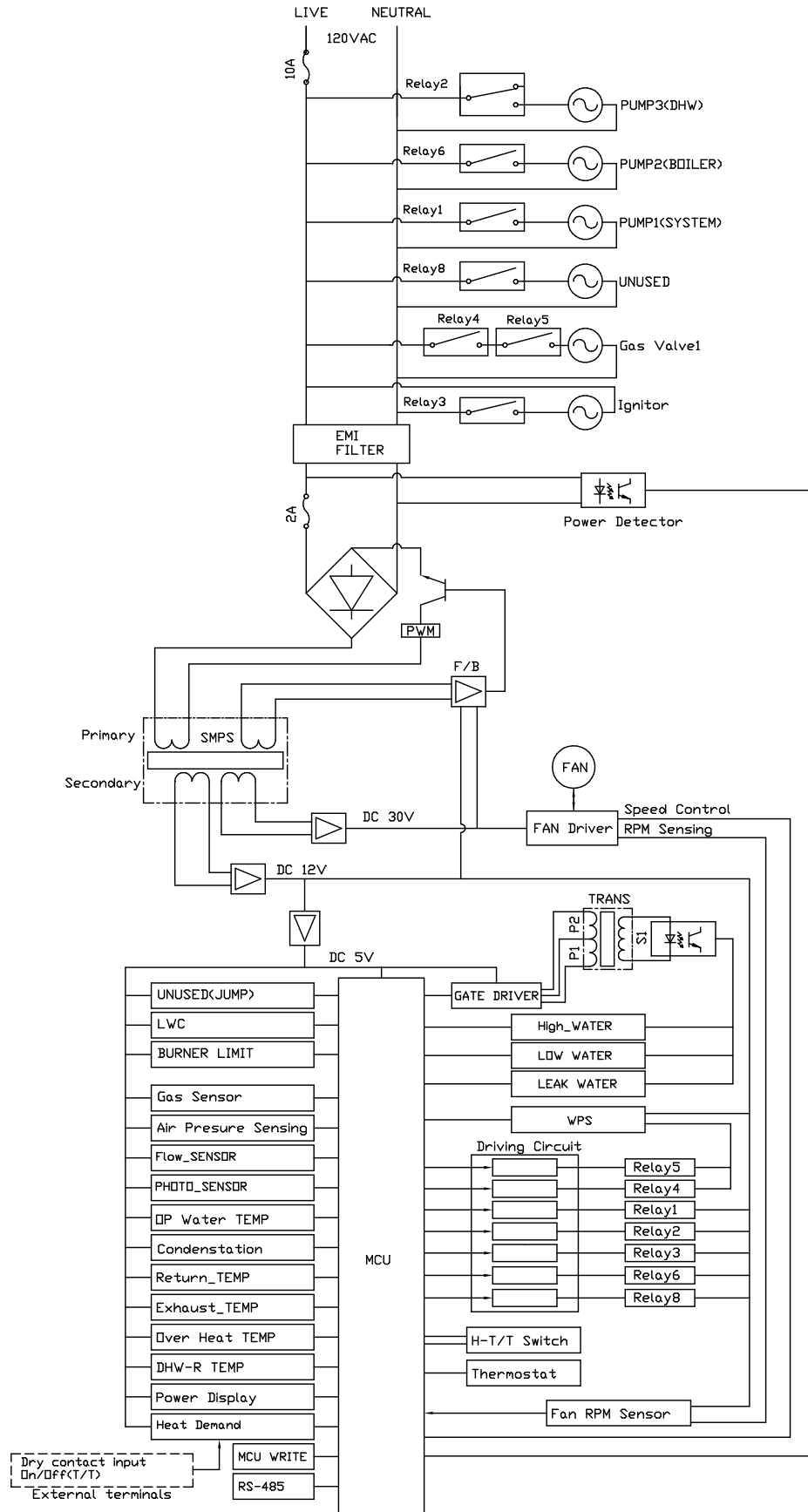

4.24 Electrical Connections, (table)

Connector			Description	HT SELV
#, Location, Type	PIN	Label		
CN9 65001WS-12	1	-	GROUND	HT (120V~)
	2	L	Power Supply Line	HT (120V~)
	3	Heating/CP1	System Pump	HT (120V~)
	4	IT	Igniter	HT (120V~)
	5	CP2	Boiler Pump	HT (120V~)
	6	GV	Gas Valve	HT (120V~)
	7	-	-	-
	8	N	Power Supply Neutral	HT (120V~)
	9-12	— N —	AC Power COM Line	HT (120V~)
CN6 LW6A4-03	1	CP3	DHW Recirc Pump	HT (120V~)
	3		HT (120V~)	
CN1 SMW250-5D	1	RS-485	RS485 (+)	SELV (5V)
	2		RS485 (-)	SELV (5V)
	3		GND	
	4		RS485 (+)	SELV (5V)
	5		RS485 (-)	SELV (5V)
CN4 LWD1140-06D	1	FAN	Not Used	-
	2		GND	SELV (14V)
	3		VDD	SELV (14V)
	4		Fan power(start coil)	SELV
	5		Fan power(end coil)	(8-26 Vac)
	6		Fan speed feedback signal	SELV (14V)
CN8 SMW250-04D	1	MCU ISP	GND	SELV (5V)
	2		ISP /Reset port	SELV (5V)
	3		ISP TOOL0 Data port	SELV (5V)
	4		VCC	SELV (5V)
CN11 LWD1140-16	1	HWL	Not Used	SELV (12V~)
	8			
	2	LWC	Low Water Level Leakage Sensor	SELV (12V~)
	10			
	3	HD	Heating Demand (T/T)	SELV (5V)
	11			
	4	TH	Connect to the Display Control(Thermostat)	SELV (14V)
	12			
	5	UNUSED	Jump	SELV (14V)
	13			
	6	LWC	External LWC	SELV (14V)
	14			
	7	BL	Burner Limit	SELV (14V)
	15			
	8	HL	Condensate Blocked Switch	SELV (14V)
	16			

Electrical Connections , (table) (continued)

Connector			Description	HT SELV
#, Location, Type	PIN	Label		
CN7 LWD1140-14	1	F.S	Flame Detect Sensor	SELV (5V)
	8			
	2	OP.S	Operating water temperature sensor	SELV (5V)
	9			
	3	DH.S	DHW outlet temperature sensor	SELV (5V)
	10			
	4	I.S	System return temperature sensor	SELV (5V)
	11			
	5	BG.S	Venting (Exhaust) temperature sensor	SELV (5V)
	12			
	6	ST.S	DHW Recirc Temperature Sensor	SELV (5V)
	13			
	7	SP.S	Over-Heat temperature sensor	SELV (5V)
	14			
CN10 SMW250-08D	1	Not Used		
	2	Not Used		
	3	Not Used		
	4	Not Used		
	5	H-T/T	H-T/T terminals	SELV (14V)
	6	H-T/T		SELV (14V)
	7	Not Used		
	8	Not Used		
CN3 SMW250-06D	1	APS SENSOR	VCC	SELV (5V)
	2		GND	SELV (5V)
	3		Voltage Input	SELV (5V)
	4	FLUX1	VCC	SELV (5V)
	5		Water Flow Sensor	SELV (5V)
	6		GND	SELV (5V)

SECTION 5 Control Display and Operation

5.1 Control Dial and Buttons

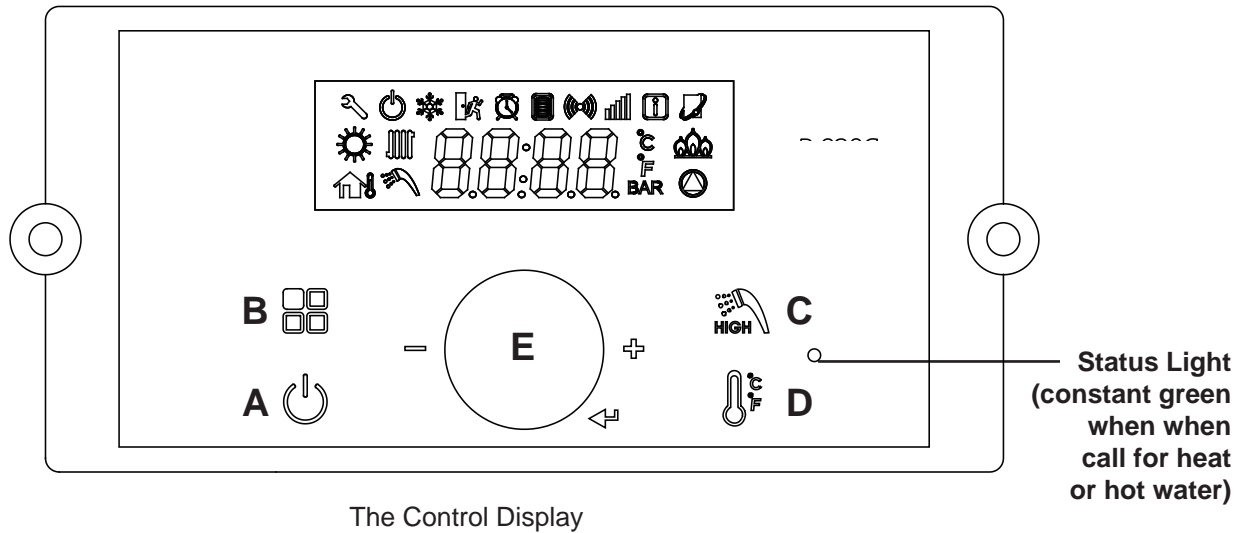

The Control Display has a Control Dial (E), 4 buttons (A, B, C, D), and a Liquid Crystal Display (with 72 back-lit segments). This section of this manual gives instruction on how to navigate into the many functions of the FT and to change temperature set points, set system variables and controller parameters.

Buttons			Function	Method	Function	Method
A		Display Power	Turns Control Display ON/OFF	Press/Tap		
B		Modes	Status Display Mode	Press/Hold (5 Seconds) (With display power on)	Return to Menu (from Status Display Mode)	Press/Tap
			Installer Mode	Press/Hold (5 Seconds) (With display power off)	Return to off display off mode (from installer mode)	Press/Tap
C		Hot Water	DHW Set point LOW Range 95 - 120°F (35 - 49°C)	Press/Tap (To return home, tap Scroll/Select)	DHW set point HIGH Range 121-140°F (49.5-60°C) (from DHW set point LOW RANGE)	Press/Hold (5 Seconds), (To return home, tap Scroll/Select)
D		Central Heat	CH set point mode (boiler only)	Press/Tap (To return home, tap Scroll/Select)	Toggle (°C/°F) (from CH set point mode)	Press/Hold (5 Seconds)
E		Scroll / Select	Turn to scroll (clockwise or counterclockwise), Tap to select	Press/Tap		

- Temperature Specifications
 - Operating ambient Temperature Range : -10 to 60°C.
 - Operating Relative Humidity up to: 90% at 40°C.
 - Shipping & Storage Temperature Range of : -20 to 80°C.

5.2 LCD Overview

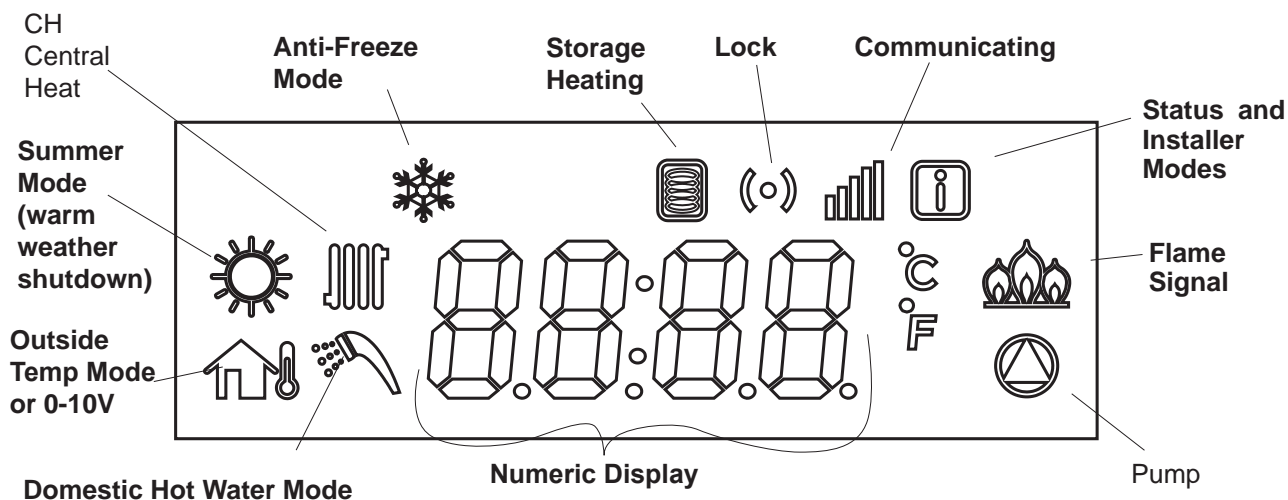

CH mode	Central Heat mode icon can be adjusted
Anti-freeze mode	Anti-freeze mode icon
Storage Heating mode	Stored Water Being Heated, can be adjusted
Lock mode	Buttons-locked mode icon
Communication	Communication icon
Summer mode	Only DHW Mode, can be adjusted (warm weather shutdown)
Status and Installer mode	The Status Mode or the Installer Mode is Active (all parameters)
Flame signal	Flame Signal icon
Pump icon	Water pump operation (CH or DHW) icon
Numeric Display	Number and character display, to display all parameters
DHW mode	Combination boiler Set Point, can be adjusted
Outside temp or 0-10 V mode	Operating by outside temperature or 0-10V

The LCD will illuminate when a user action is detected (a button is pressed) and will turn back off after 20 seconds.

* NOTE: The display will not allow changes when the lock mode (key icon) is activated.

To exit the Lock mode, press the  button.

 **WARNING**





Do not use this appliance if any part has been under water. Immediately call a qualified service technician to inspect the appliance and to replace any part of the control system and any gas control that may have been under water.

5.3 Operating Mode

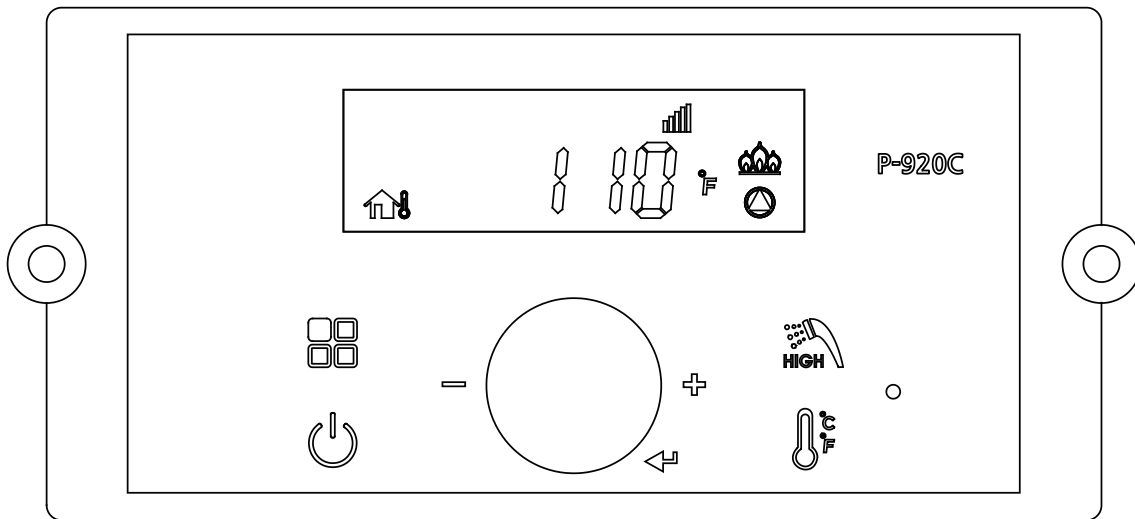
■ Operating Mode

After the Power is turned on, and/or the Control Display is turned on , the Control Display will go through a 'Start Up' checklist and briefly show a sequence of diagnostic codes before entering into the 'Operating Mode'. It will then display the following information.



Indicate	Example
Current Operating Temperature	110°F
Temperature sign Celsius or Fahrenheit letter	°C or °F
Display and Controller are communicating	
If flame detected	
If pump is operating	
Outdoor sensor or 0-10V	
Call for Heat	

Note: The house symbol will blink when the outdoor sensor is not connected to the boiler.

5.4 Status Display Mode

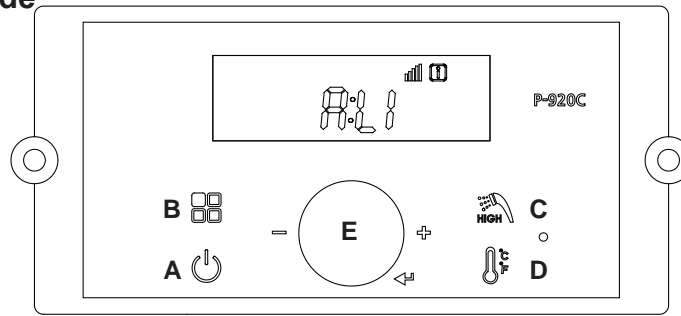

1. STATUS DISPLAY MODE (When button is pressed for 5 seconds When power to display panel is ON , status display will be activated)

Digital Display	Status Display Parameter	Description	
O:ot	Outdoor temperature (when --- is displayed, no outdoor sensor is connected)	Current outdoor sensor temperature	
A: Li or A: GA	DHW Flow Rate	Current DHW Flow(Li: L/m, GA: GPM)	
b: It	CH Return Water Temperature	Current Return Water Sensor Temperature	
C: Fr	Fan rpm	Current FAN speed (RPM)	
d: Lc	Lock mode	Lock mode ON/OFF	
E: oP	CH supply temperature (Operating temperature)	Current Boiler Supply temperature	
F: dH	DHW temperature (Operating temperature)	Current DHW temperature	
H: Eh	Exhaust gas temperature	Current exhaust gas temperature	
I : St	DHW Recirculation temperature (when 0 F is displayed, no DHW Recirc sensor is connected)	Current DHW Recirc water temperature	
J: oH	CH Overheat Temperature	Current CH Overheat Temperature	
L: rt	1: PH	Time for supply power	Unit : 1000hour
	2: rh	Time for burner operation	Unit : 1hour
	3: rH	Time for burner operation	Unit : 1,000hour
	4: It	Cycle for ignition	Cycle: 10 times the displayed unit
	5: IH	Cycle for ignition	Cycle: 10,000 times the displayed unit
P: Ou	PUMP Operation		Current PUMP Operation (CP1) (CP2) (CP3) All Activate CP2 activate
	CP1	System PUMP	
	CP2	Boiler PUMP	
	CP3	DHW Recirc PUMP	

To view any of the above listed Status Parameters,

Press and Hold Button B to get into the Status Display Mode.

Rotate Dial E until you find the Parameter that you wish to view. Tap Dial E to enter that Parameter.

Adjust to the setting that you require and then press (tap) Dial E to save and to Exit.

5.5 DHW Set Point Change Mode



■ DHW Set Point Change Modes

The display shows the following information when changing water heating temperature set points.

Changing between Celsius and Fahrenheit

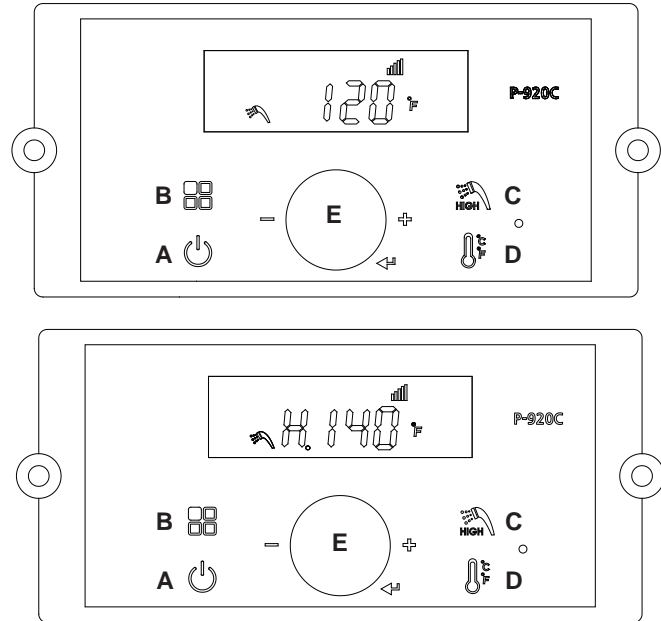
When the button D  is pressed (for more than 5 seconds), temperature unit will toggle between °C and °F.



Indicate	Example
Current DHW set point temperature	120°F
Temperature sign Celsius or Fahrenheit letter	°C or °F
If display is communicating with the main controller normally, the communication icon will be indicated.	
When DHW set point range is high : from 121°F (49.5°C) to 140°F (60.0°C)	H . 140°F
When changing DHW set point, the DHW icon will flash	

* Default DHW set point is 125°F (51.5°C)

• **DHW 95-120°F (35 - 49°C) LOW range (Default)**

-To change **LOW range**, press the C Button. The DHW icon and current DHW LOW will flash (a flashing value means it can be changed).

- Turn dial E clockwise to increase and counterclockwise to decrease until desired temperature is reached.
- Press dial E to save set point changes.

• **DHW 121 - 140°F (49.5 - 60°C) HIGH range**

-To change **HIGH range**, press and **HOLD** the C button for more than 5 seconds. The DHW icon and current DHW HIGH will flash (a flashing value means it can be changed).

- Turn dial E clockwise to increase and counterclockwise to decrease until desired temperature is reached.
- Press dial E to save set point changes and to Exit.



Scalding may occur within 5 seconds at a setting of 140°F (60°C). Water temperatures over 125°F can cause severe burns, or death from scalding. Children, disabled, and elderly are at highest risk of being scalded. Read all instructions before setting temperature at appliance. Feel water before bathing or showering.

Manufacturer requires the installation of the supplied anti-scald mixing valve at domestic hot water outlet (boiler location) to reduce potential for scalding. See See section 4.16.4 for DHW piping installation details. Check with local codes.





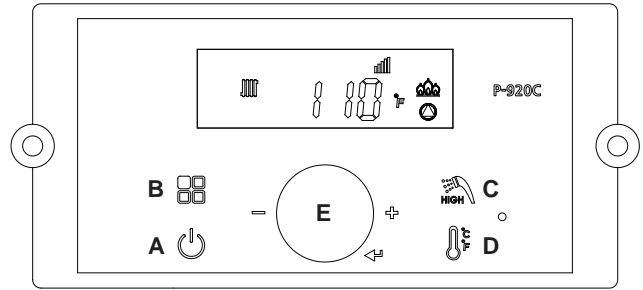

5.6 CH Set Point Change Mode

Changing between Celsius and Fahrenheit

When the button D  is pressed (for more than 5 seconds), temperature unit will toggle between °C and °F.



Indicate	Example
Current Operating Temperature	110°F
Temperature sign Celsius or Fahrenheit letter	°C or °F
Display and Controller are communicating	
If flame detected	
If pump is operating	
When changing CH Set point, the CH Icon will flash	

Default CH set point is 130°F (54°C)





CH set point range is 130 - 180°F (54.4 ~ 82.0°C)

To change CH Set point, press the D  button. The CH Icon and current CH Set point will flash.

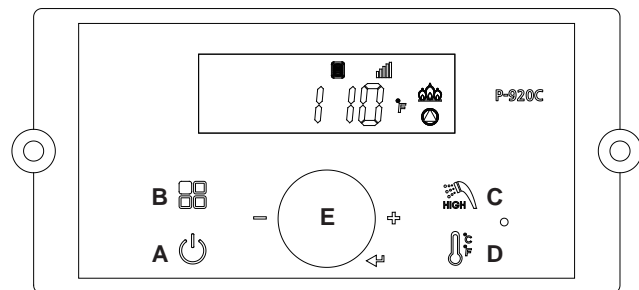
Turn the E dial clockwise to increase, and counterclockwise to decrease CH set point, until desired temperature is reached. Press E dial to save changes and to Exit.

5.7 Storage Mode



Indicate	Example
Current Operating Temperature	110°F
Temperature sign Celsius or Fahrenheit letter	°C or °F
Display and Controller are communicating	
If flame detected	
Storage mode indication	
If Pump is operating	

To activate heat storage function, First turn OFF the power to the Control Display.

Then Press and Hold Button B  to get into the Installer Mode.

Rotate Dial E until you find **5:St** Tap Dial E to enter Storage Mode. Storage Mode indicates that the boiler is maintaining the water temperature in the internal storage tank. When Storage Mode is active, the display will appear as shown. Turn the E dial clockwise to activate and counterclockwise to deactivate the Heat storage function. Default: ON. Press E dial to save changes and to Exit.

5.8 Installer Parameters

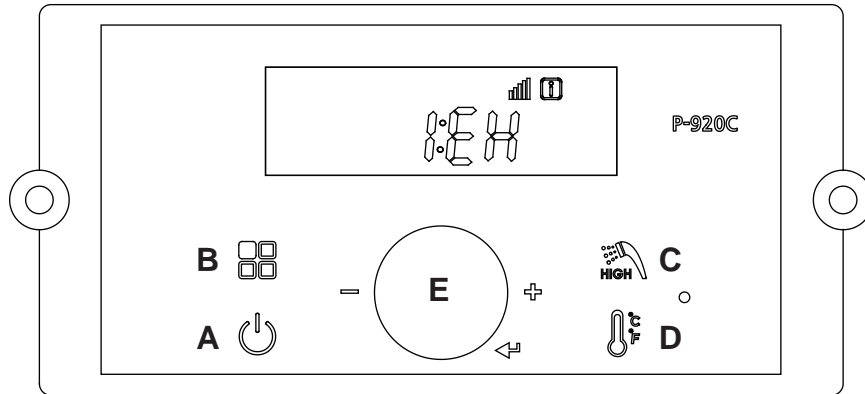

⚠ WARNING

For low temperature heating applications, adjust P16 and possibly P17 to desired value(s). Proper high temperature protection might be required when the combination boiler transitions from DHW production to low temperature heating. Contact Technical Services for assistance in changing settings.

These changes are to be made only by a qualified technician.

To change any of the Installer Parameters

Start by turning **OFF** the Power to the Display Control.

Then, with the power OFF, Press and HOLD (more than 5 seconds) the Button B  to get into the Installer Mode.

Rotate Dial E until you find the Installer Parameter (full list on facing page) that you wish to change. Tap Dial E to enter that Parameter.

Adjust to the setting that you require and then press (tap) Dial E to save and to Exit.

Finish by pressing button B 

5.8 Installer Parameters (continued)

Index	Default	Parameter	Description
1: EH		Error History	History fault code (E0~E9)
2: cE	OFF	Clear Error History	Clearing of error History buffer
3: In	OFF	System initialize	System initialize to default
4: Fu	GA	Flow unit	gallon / liter
5: St	On	Heat storage function	Heat storage function On/Off
6: OH	68°F (20°C)	Maximum Outdoor Temperature	Range: (Minimum Outdoor Temperature + 9°F) to 110°F
7: OL	30°F (-1°C)	Minimum Outdoor Temperature	Range: -4°F to (Maximum Outdoor Temperature -9°F)
8: FH	0	Max fan	Adjusts Maximum Fan Speed Range: -30 - +30 Default 00 Note: Factory set - do not adjust
9: FL	0	Min fan	Adjusts Minimum Fan Speed Range: -30 -+30 Note: Factory set - do not adjust
10: dr	NO	Delete running time	Delete running time
11: dl	NO	Delete igniting times	Delete igniting times
12: bt	0	Outdoor reset Boost Delay Time	When using the outdoor reset sensor, if a call for heat is longer than Boost delay time, the boiler will Boost to the maximum supply water temperature - see parameter 16CH. (0~120 min)
13: Ft	1 min	Delay time for heating burner operation	Burner does not operate during the delay time when the burner is turned off due to the temperature during heating operation. (0~20 min)
14: bo	15°F (10°C)	Burner ON differential	Heating temperature setting during heating operation – Operate in burner ON temperature setting Range: 9 - 27°F (5 - 15°C)
15: OF	110°F (38°C)	Warm Weather Shutdown	This warm weather temperature setting will shut down CH Mode. Range: 50 - 110°F (10 - 43°C).
16:cH	180°F (82°C)	Setting for Heating Maximum Temperature	Range: 9°F less than Minimum Temperature to 180°F 5°C less than Minimum Temperature to 82°C
17:cL	130°F (54°C)	Setting for Heating Minimum Temperature	Range: 86°F to 9 degrees °F less than Maximum Temperature
18:dH	140°F (60°C)	Setting for Hot Water Maximum Temperature	Range: 120°F - 140°F (49°C to 60°C)
19:cb	100%	Heating Combustion Rate	Range: 50%~100%
20:db	100%	Hot Water Combustion Rate	Range: 50%~100%
21:PP	40 min	Boiler pump post burner limit run time	(Boiler Pump) 1 min - 60 min. As long as TT is closed, boiler and system pump both run, even when boiler hits high limit. (TT is closed).
22:Po	5 min	Pump on Time	(Boiler Pump Repeat ON Time) Range: 1 min ~60 min (While TT is closed)
23:PF	0 min	Pump off Time	(Boiler Pump Repeat Off Time) Range: 0min ~60 min (While TT is closed)
24:SF	150°F (66°C)	Storage off temperature	Range: 140°F - 180°F (60°C to 82°C)
24:SF	105°F (41°C)	DHW Recirculation off temp (when DHW/Surface sensor is connected)	Range: 95°F - 140°F (35°C to 60°C) The range is automatically changed when DHW/Surface sensor is connected.
25:So	18°F (10°C)	Storage on Δtemp	Range: 9°F - 36°F (5°C to 20°C)
25:So	9°F (5°C)	DHW Recirculation on temp (when DHW sensor or aquastat is connected)	Range: 9°F - 27°F (5°C - 15°C) The range is automatically changed.
26:dt	0 min	Smart DHW Priority Delay time	Range: 0 – 2 minutes. If Smart DHW Priority is ON (see parameter P36), a call for domestic hot water will be prioritized by the boiler for delay time value. The boiler will turn heating back on as long as boiler can satisfy both domestic and heating demands otherwise, heating will remain off until domestic demand has ended.
27:PE	1 min	Internal Boiler Pump and system pump Post-Purge Time, T/T Satisfied	Allows the user to set the boiler pump and system pump post purge time once the appliance CH set point and thermostat are satisfied. Range: 1-5 minutes
28: HA	0-2	High Elevation Mode	High Elevation Mode: 0 - 2, 2 - 5, 5 - 8, 8 - 10 Default: 0 - 2 0 - 2: 0 - 2,000 ft 2 - 5: 2,000 - 5,000 ft 5 - 8: 5,000 - 8,000 ft 8 - 10: 8,000 - 10,000 ft

Index		Default	Parameter	Description	
29: AP	AP:cP	5	CH System Pump and DHW Indirect Pump Test Mode	This function sets the time to run Boiler pump to purge air from the system. Range: 1 – 30 minutes	
	cP:Off or cP:On	OFF	Boiler Pumps Test Mode	Turn this function on to activate Boiler pump. Only works in installation mode. Turns off when in normal mode.	
30: dP		4 hrs	DHW Timeout Feature	Range: 0 - 12 hours, '0' OFF	
31: SA	AqUA	dHr	Select AqUA or dHr	Select Storage Type, Aquastats or DHW-recirc Sensor (Affects P24: SF, P25: So) - Aqua: DHW Recirculation Operation with aquastat (not supplied) - dHr: DHW Recirculation Operation with DHW-R / surface sensor (optional equipment) - dHr Sensor not connection: Storage Operation	
	dHr				
32: rC		15 min	DHW in stand-by, DHW recirc pump not running for recirc for 15 min. (Applies when not using DHW-R sensor or aquastat; pairs with P33)	Range: 1 – 60 (min)	To run continuously between rC and rt If flow is detected, rC timer resets to zero.
33: rt		10 min	DHW recirc pump run time to reach DHW recirc temp.	Range: 0 – 15 (min)	
34: HF		80%	Hybrid Off Firing Rate (DHW mode change: CH-Off, DHW ON)	Activated during “Smart” DHW function, Boiler firing rate has reached set maximum heating rate, deactivate the external CH pump for DHW priority, Range 50 - 90%	
35: Hn		50%	Hybrid On Firing Rate (CH mode change: CH + DHW)	During activate “Smart” DHW function, Boiler firing rate has reached set minimum firing rate, activate external CH pump, Range 30 - 50%	
36 : Ho		ON	“Smart” DHW mode: ON/OFF	Activate “Smart” DHW operating function: ON/OFF When set to ON, it operates in hybrid mode. When set to OFF, it operates in normal mode. (DHW priority)	

5.9 Outdoor Reset Adjustment

Outdoor Reset varies the control set point based on the outdoor temperature. The reset function works as shown in Figure 'CH Outdoor Reset'. When the outdoor air temperature reaches 6:OH "high outdoor temperature set point", the control point setting is adjusted to 17:cL "low boiler temperature set point". When the outdoor air temperature reaches 7:OL "low outdoor temperature set point" the control set point is adjusted to 16:cH "high boiler temperature".

Default Warm Weather Shut Down set point is 100°F (38°C)

The Outdoor Temperature Mode Icon on the display will flash if an Outdoor Sensor or 0-10 Volt is not connected to the appliance.

To check the CH Target Temperature while using Outdoor Temperature Mode, press the  button while the appliance is operational and the display panel is powered on.

Connect the outdoor sensor to terminal strip as outlined 4.20 Electrical Connections.

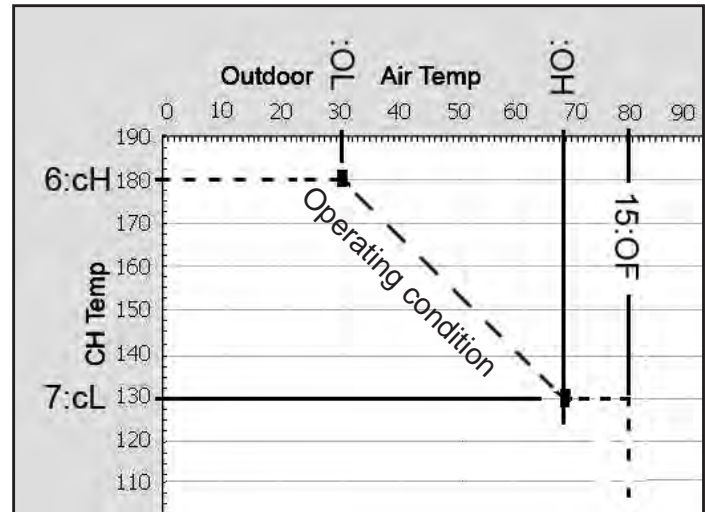

CH Outdoor Reset

Note: In this example, the Summer Mode (Warm Weather Shut-down) is set to 80°F (= P15).

(Summer Mode)

5.10 External Set Point Temperature Control

A signal from a building management system may be connected to the appliance to enable remote control. This signal should be a 0-10 volt DC signal. When this input is enabled, a building control system can be used to control the set point temperature of the appliance.

The control interprets the 0-10 volt signal as follows; when the signal is between 0 and 1.5 volts, the appliance will be in standby mode, not firing.

When the signal rises above 1.5 volts, the appliance will ignite. As the signal continues to rise towards its maximum of 10 volts, the appliance will increase in set point temperature. Adjust 16:cH and 17:cL to set MIN and MAX boiler water temperatures respectively.

Connect a building management system or other auxiliary control signal to the terminals marked for this purpose on the appliance terminal block (shown in Piping Diagrams, this manual). Caution should be used to ensure that the 0-10 VOLT + connection does not become connected to ground.

Connect to terminal strip as outlined 4.20 Electrical Connections.

NOTE: 0 - 10VDC terminals can not be used for both outdoor reset and 0 - 10VDC temp set point simultaneously.

5.11 Error Mode

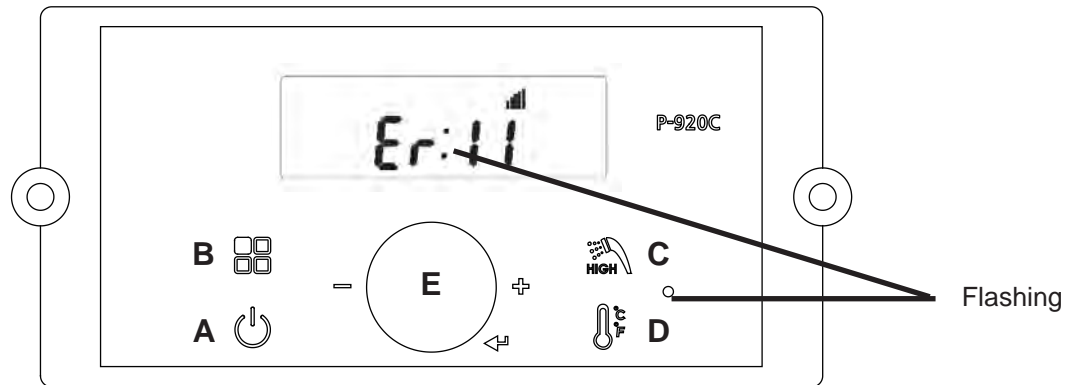

Indicate	Example
Error ' Er : ' will flash	Er:11
Error Code	Er:11
Display and Controller are communicating	

NOTE: When communication between the Control Display and the main controller is lost, the  will not be displayed.

Note: This space is intentionally left blank.

SECTION 6 Error Codes**6.1 Error Code Tables**

Error Code	Error Code Description	Possible Remedies	Recover methods
10	Combustion fault Flame has Extinguished 8 (Eight) Times	<p>Press the Power button to clear the Error Code. If Error happens again:</p> <ol style="list-style-type: none"> 1. Monitor the gas pressure to the appliance while in operation. Ensure pressure is between 3.5" to 10.5" WC (Nat. Gas) and 8" to 13" WC (Propane). 2. Check gas valve wire. Ensure connection is secure. 3. Check flame detection sensor. Ensure connections are secure. Normal operating settings are more than 2.5DC before ignition, less than 2.5DC after ignition. 4. Check exhaust and intake terminations for blockages. Also verify that intake, intake boot, blower and burner housing is free of blockages and debris. 5. Assure that the flame is stable when lit. Confirm Flame stability by manually forcing the boiler into Low Fire (see section 4.20) - Burner should not cycle on and off in low fire. If burner cycles on/off during low fire operation adjust fuel/air mixture and confirm CO₂ values are within range for model and fuel type. 6. If the problem persists, contact technical support. 	Hard Lock
11	Ignition fault Ignition has Failed 10 (Ten) Times	<p>Press the Power button to clear the Error Code. If Error happens again:</p> <ol style="list-style-type: none"> 1. Monitor the gas pressure to the appliance while in operation. Ensure pressure is between 3.5" to 10.5" WC (Nat. Gas) and 8" to 13" WC (Propane). 2. Check gas valve wire. Ensure connection is secure. 3. Check flame detection sensor. Ensure connections are secure. Normal operating settings are more than 2.5DC before ignition, less than 2.5DC after ignition. 4. Check igniter transformer for proper connection. 5. Clean the spark igniter with steel wool to remove oxides. Ensure proper separation (3-4 mm). 6. Replace the spark igniter if damaged. 7. Assure that the flame is stable when lit. 8. If the problem persists, contact technical support. 	Hard Lock
16	Water temperature over-heating fault Operating Temperature Sensor detects Water Temperature Greater than 203°F (95°C)	<p>Press the Power button to clear the Error Code.</p> <p>If boiler is not piped Primary/Secondary it is likely the internal boiler pump is not able to move enough water thru heat exchanger. If Error happens again:</p> <ol style="list-style-type: none"> 1. Check if dip switch Max Fire setting is ON. Switches 6 and 7 should be OFF for normal operation. 2. Check if CH inlet pipe is blocked. Ensure there is enough water flowing to the appliance. 3. Check Operating Temperature sensor at CH heat exchanger outlet. If resistance is zero, replace the sensor. 4. Verify operation of internal boiler pump by checking rotation of pump shaft. (Manually spin pump shaft by inserting a flat head screwdriver. You may need to remove a side panel knock-out for better access). 5. If the problem persists, contact technical support. 	Hard Lock
20	Blocked condensate switch fault	<p>Press the Power button to clear the Error Code.</p> <ol style="list-style-type: none"> 1. Check Condensate and main controller connections. Ensure all are secure. 2. Check Condensate sensor resistance. If resistance is zero, replace the switch. 3. Check Condensate hose. Ensure it is connected and in good condition. 4. Check condensate line and termination for blockages. 5. Check Vent Pipe for blockages. 6. If the condensate is "hard piped" in the field, install a vent in the piping at a point higher than the condensate trap. 7. If the problem persists, contact technical support. 	Hard Lock
28	Overheat sensor fault	<p>This Error Code will go away when CH temperature decreases. If Error happens again:</p> <ol style="list-style-type: none"> 1. Check overheat temperature sensor. Ensure connections are secure. 2. Check overheat sensor resistance. If resistance is zero, replace the sensor. 3. If the problem persists, contact technical support. 	Soft Lock
29	Factory installed Jumper missing or not connected.	<ol style="list-style-type: none"> 1. Check upper left plug on PCB board. Reconnect blue jumper wire part of this plug. 2. Press the Power button to clear the Error code. Error occurs when the blue wire inside the KI-I9CCWL plug (upper left corner of PCB board) is shorted to ground or has a poor contact. 	Hard Lock
30	DHW-R sensor short	<p>This Error Code will go away when the condition is remedied. If Error happens again:</p> <ol style="list-style-type: none"> 1. Check DHW recirc sensor. Ensure connections are secure. 2. Check DHW recirc sensor resistance. If resistance is zero, replace DHW recirc sensor. 3. If the problem persists, replace the main control. 	Soft Lock
32	DHW outlet sensor fault	<p>This Error Code will go away when CH temperature decreases. If Error happens again:</p> <ol style="list-style-type: none"> 1. Check DHW or CH temperature sensor. Ensure connections are secure. 	Soft Lock
33	OP Water temperature sensor fault	<ol style="list-style-type: none"> 2. Check DHW or CH sensor resistance. If resistance is zero, replace the sensor. 3. If the problem persists, contact technical support. 	

SECTION 6. Error Codes (continued)

Error Code	Error Code Description	Possible Remedies	Recover methods
32	DHW outlet sensor fault	This Error Code will go away when CH temperature decreases. If Error happens again: 1. Check DHW or CH temperature sensor. Ensure connections are secure. 2. Check DHW or CH sensor resistance. If resistance is zero, replace the sensor. 3. If the problem persists, contact technical support.	Soft Lock
33	OP Water temperature sensor fault		
36	Main power fault	Supply voltage is too low to operate. This Error Code will go away when supply voltage returns to normal operating range. If Error happens again: 1. Ensure appliance is properly wired to a power source meeting the requirements on the rating plate. 2. If problem persists, contact technical support.	Soft Lock
37	Power frequency fault	Supply frequency is too high to operate. This Error Code will go away when supply frequency returns to normal operating range. If Error happens again: 1. Ensure appliance is properly wired to a power source meeting the requirements on the rating plate. 2. If problem persists, contact technical support.	Soft Lock
38	EPROM fault	Press the Power button to clear the Error Code. If the problem persists, contact technical support.	Hard Lock
40	Gas leakage fault	IMPORTANT: If you smell gas, STOP! Follow the instructions on page 2, this manual, and call a qualified service technician or the fuel gas utility. Press the Power button to clear the Error Code. If Error happens again: 1. Check the appliance cover. Ensure it is secure. 2. Check gas connections for leakage with a soapy solution. Fix any leaks. 3. Check condition of the burner assembly. 4. If the problem persists, contact technical support.	Hard Lock
41	Fan high RPM fault	Press the Power button to clear the Error Code. If Error happens again: 1. Check the vent connections for blockages. 2. Check the burner assembly. 3. Check fan operation. If fan appears to be operating normally but RPMs are too high, replace the fan. 4. Check intake and exhaust for blockages, debris, proper installation and placement. Check and record SFN (revision # of printed circuit board during start-up for future reference). 5. If the problem persists, contact technical support.	Hard Lock
42	External LWCO/ safety fault	Press the Power button to clear the Error Code. If Error happens again: 1. Ensure the LWCO jumper wire is properly connected. 2. If the problem persists, contact technical support.	Soft Lock
43	Burner over-heating fault	Press the Power button to clear the Error Code. If Error happens again: 1. Check burner overheat switch connections. Ensure connections are secure. 2. Check switch resistance. If resistance is zero, replace the switch. 3. If the problem persists, contact technical support.	Hard Lock
44	Air Pressure Sensor Range (APS) Fault	Press the power button to reset If error happens again: 1. Check the vent pipe for blockages. 2. Check the air intake pipe for blockages. 3. inspect the Venturi and fan motor, the air intake screen at the fan connection (for the 140 only) or the burner itself for any debris that could have been drawn in by the fan thru the air intake. 4. If error do not clear, replace the APS 5. If the problem persists, contact technical support.	Hard Lock
45	Air Pressure Sensor Fault	Check the aps connection. 1.If APS is closed and connections are secure, check APS connection. 2. If the problem is not happen, replace the APS 3. If the problem persists, contact technical support.	Soft Lock
61	Fan fault	This Error Code will go away when the condition is remedied. If Error happens again: 1. Check the connections to the fan. Ensure all are secure. 2. Check intake and exhaust for blockages and debris. 3. If the fan does not rotate during the ignition sequence, check for AC8V~26.5V power at the fan connection. If AC8V~26.5V power is present at the control, replace the fan. If the blower does not have AC8V~26.5V power, check power at the control. If AC8V~26.5V power is not present at the control, replace the control. 4. If the problem persists, contact technical support.	Soft Lock

Error Code	Error Code Description	Possible Remedies	Recover methods
70	MCU self diagnostics fault	This Error Code will go away when the condition is remedied. If Error happens again: 1. Turn power OFF and ON at the main power switch internal to the appliance. 2. If the problem persists, contact technical support.	Soft Lock
72	Flame Signal Fault	This Error Code will go away when the condition is remedied. If Error happens again: 1. Check the appliance cover. Ensure it is secure. Flame detection sensor can detect an external light source. 2. Look thru boiler sight glass and check for glowing after burner shutdown. If you see glowing, do step 3. 3. Check burner plate by removing blower and boiler top plate and remove any debris from top of burner plate. Debris can come from PCV shavings during intake installation and/or from nearby dryer vents and landscapers causing debris being pulled in thru the air intake. Debris can glow after burner shutdown. 4. Check flame detection sensor. Ensure connections are secure. Normal operating settings are more than 2.5DC before ignition, less than 2.5DC after ignition. 5. If the problem persists, contact technical support.	Soft Lock
76	Display to main control communication fault	This Error Code will go away when the condition is remedied. If Error happens again: 1. Check connections from main control to display panel. 2. If the problem persists, replace the display and/or contact technical support.	Soft Lock
77	Outdoor sensor error	This Error Code will go away when the condition is remedied. If Error happens again: 2. Check outdoor sensor resistance. If resistance is zero, replace the sensor. 3. If the problem persists, contact technical support.	Soft Lock
80	Internal low water cut-off fault	This Error Code will go away when the condition is remedied. If Error happens again: 1. Ensure all valves are open to the appliance and there are no leaks. 2. Ensure all air has been purged from the system. 3. Check wiring connections to low water level sensor. Ensure all are secure. 4. Check low water level sensor resistance. If resistance is zero, replace the sensor. 5. If the problem persists, contact technical support.	Soft Lock
81	Internal low water cut-off fault	This Error Code will go away when the condition is remedied. If Error happens again: 1. Ensure all valves are open to the appliance and there are no leaks. 2. Check wiring connections to low water level sensor. Ensure all are secure. 3. Check low water level sensor resistance. If resistance is zero, replace the sensor. 4. If the problem persists, contact technical support.	Soft Lock
85	Anti-freeze fault (Appliance has detected water temperature below 34°F(1°C))	This Error Code will go away when the freezing condition is remedied. If Error happens again: 1. Ensure appliance is located in a mechanical room protected from freezing conditions. 2. Ensure all valves are open to the appliance, there are no leaks. 3. Check wiring connections to low water level sensor. Ensure all are secure. 4. Check low water level sensor resistance. If resistance is zero, replace the sensor. 5. If the problem persists, contact technical support.	Soft Lock
94	Exhaust gas temperature fault	This Error Code will go away when the condition is remedied. If Error happens again: 1. Check if dip switch Max Fire setting is ON. Switches 6 and 7 should be OFF for normal operation. 2. Check exhaust temperature sensor. Ensure connections are secure. 3. Check sensor resistance. If resistance is zero, replace the sensor. 4. Check exhaust vent for blockage. 5. If the problem persists, contact technical support.	Soft Lock

6.2 Fault Tree Analysis

1. Flame detection

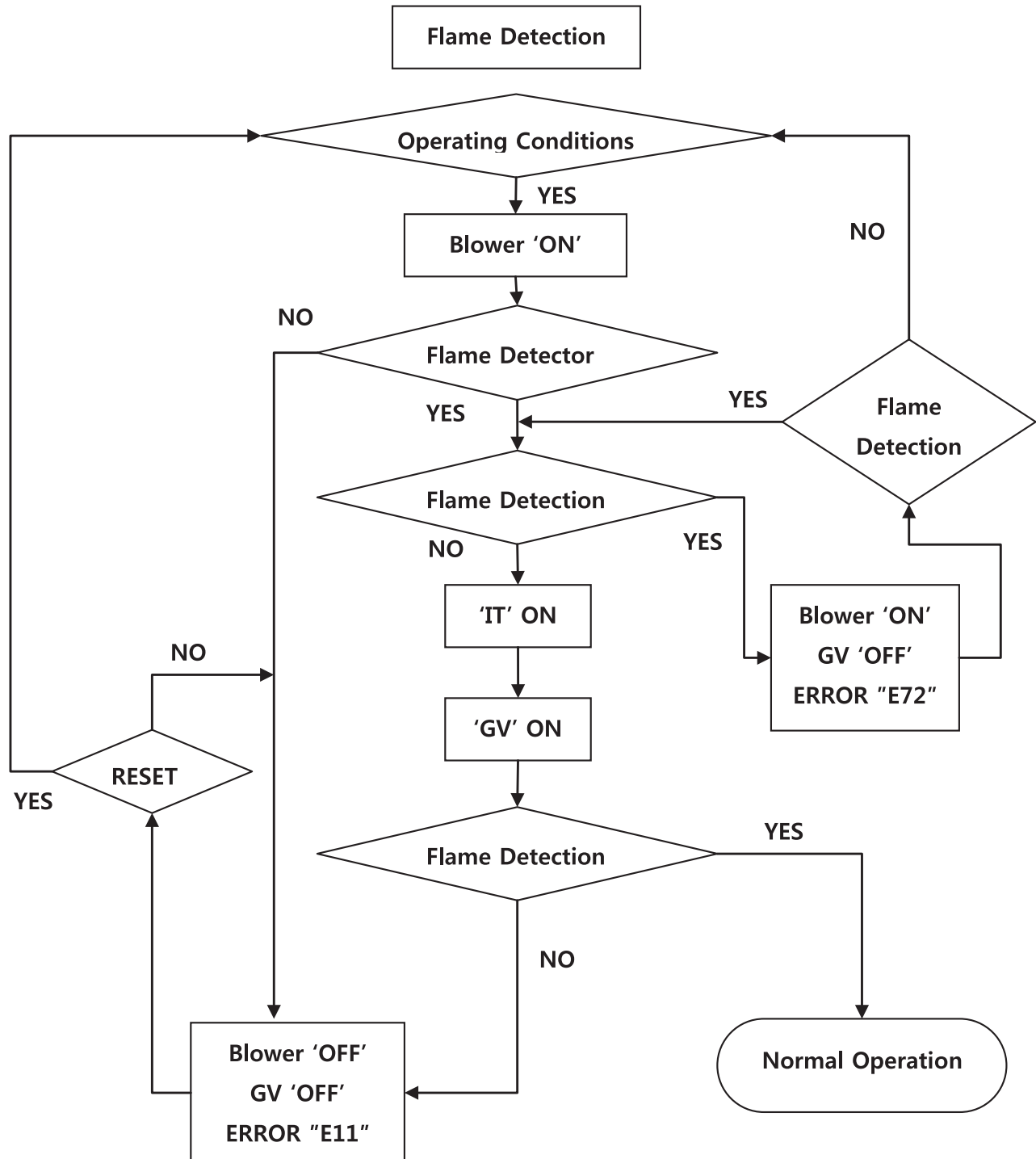

6.2 Fault Tree Analysis (cont)

2. Gas Detection

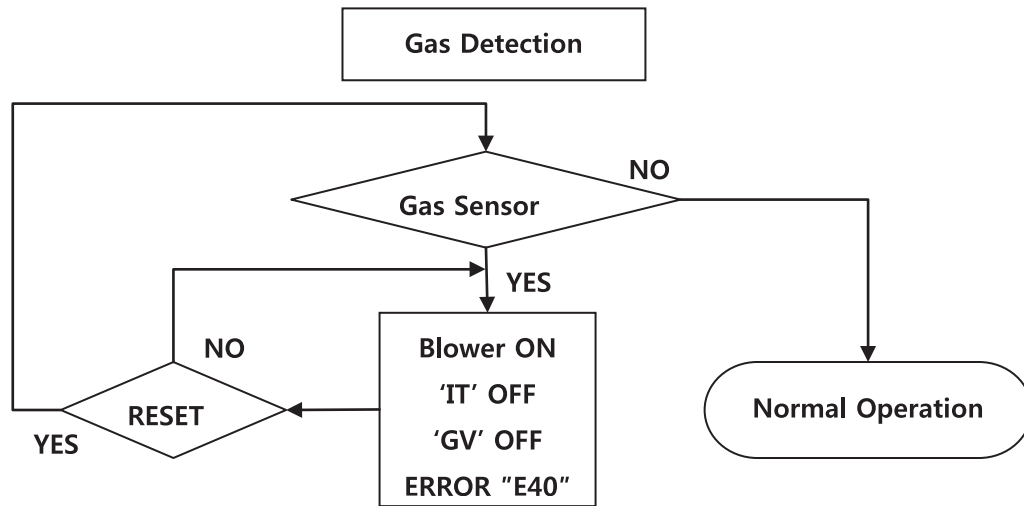

3. 'Storage', 'DHW', 'OP', 'CH overhear', 'Exhaust heat' Sensor detects

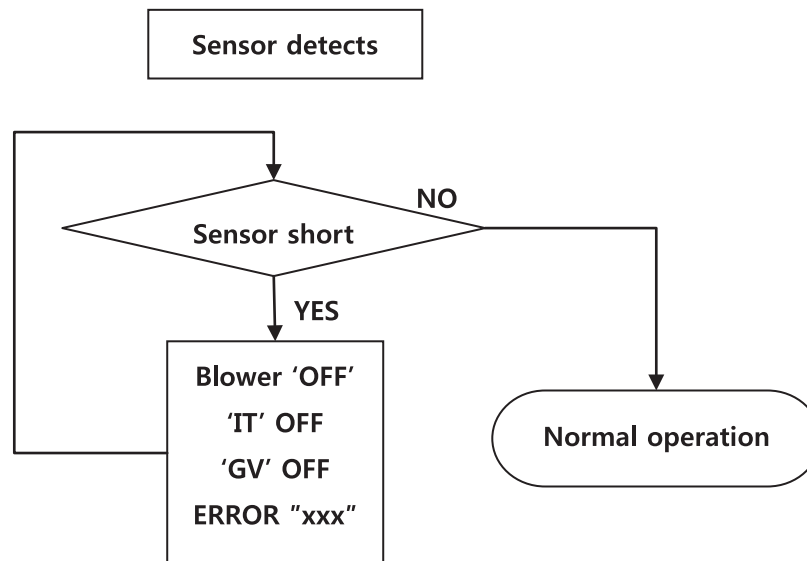

Error code	contents
E32	DHW NTC open or short
E33	OP NTC open or short
E35	Exhaust NTC open or short

SECTION 7 Trouble Shooting

7.1 Diagnostics

Question	Answer
Burner does not ignite when the hot water is opened.	Make sure that the ON/OFF button on the Control Panel has been turned ON.
	If the monitor on the Control Panel is blank, make sure the power cord is plugged and 4A fuses on the main controller in the units are good.
	Make sure that there is water supplied to the unit. The unit activates once the inlet water flow is over 0 gpm.
	Make sure the cold and hot water lines are not plumbed in reverse side.
	Make sure that the cold water and gas supply lines are opened.
Water is not hot enough.	Make sure that the water lines are not frozen.
	Check that the setting temperature on the unit is not too low
	Make sure that the filter in the cold water supply line is not clogged with debris.
	Make sure that the gas supply type is correct.
	Check the supply and manifold gas pressures are in accordance with specifications.
Water is too hot.	Make sure that the water flow sensor with three wires has been properly connected on the top of heat exchanger.
	Make sure that the setting temperature on the unit is not too hot.
	Make sure that the filter in the cold water supply line is not clogged with debris.
	Make sure that the gas supply type is correct.
Hot water temperature fluctuates at the opened tap.	Make sure that the filter in the cold water supply line is clean.
	Make sure that the gas supply type is correct.
	Check the supply gas pressure is sufficient.
The blower is still operating after the combustion stops.	This is normal because the blower keeps operating for 1 minute to vent (exhaust) the flue gas from the chamber once the combustion has stopped.
Temperature Rise too Quickly	Occurs when supply water temperature in heat exchanger rises faster than 2°F per second during the first two minutes the burner is on. Automatically resets after a few minute delay or using manual reset on control panel. See message displayed TEMPERATURE SENSOR and follow procedure for loose connections.
Abnormal sounds come from unit during operation.	A leak of combustion gas between sealed chamber and exhaust tube inside the unit. Call a qualified service technician for evaluation.
	Improper venting termination, make sure that the venting termination complies with specification.
	Check the supply gas pressure is sufficient. Insufficient gas pressure will cause unstable burner flame and noise.
Heater doesn't fire when DHW flow is initiated	Potentially the domestic water flow is too low. Min allowable is 0.75 gpm. Check in Manual Mode OTO AGA
CH Temp drops lower than expected before unit re-fires	Change Parameter 14:bo to 10 degrees F (5.5 degrees C)

7.2 Suggested Corrective Actions

This controller is able to record information about the boiler's condition at the time of the five previous faults or errors. Refer to the Section '5.10 Error Mode' of this manual.

Display	Condition	Diagnostic	Corrective Action(s)
Nothing shown on display control panel and blower running at full speed.	Control is not receiving power.	Check wiring for short circuit or incorrect wiring.	Correct wiring per wiring diagram including connection of transformer to the control.
		Check transformer connection to the control per wiring diagram. Check for 12V output of transformer.	Replace transformer if it is receiving 120V, but not outputting 12Vac.
Nothing is shown in display control panel and no other boiler components are operating.	Control is not receiving 120V power.	Check service switch and/or circuit breaker to boiler turned is on.	Turn on service switch to power boiler.
		Is there 120 Volts at the service switch?	Troubleshoot and correct the power supply to the manual switch.
		Is the ON/OFF POWER SWITCH (inside boiler case) turned on?	Turn ON the manual power switch inside the boiler case.
		Check for 120 volts at the line voltage terminal block located inside the boiler case.	Correct wiring inside the boiler case using the wiring diagram in this manual.
		Inspect the fuse. Replace if necessary.	Replace the fuse with proper part found in the replacement part section of this manual. If fuse blows again recheck wiring per diagram.
Nothing is shown on control panel, but boiler is operating.	Occurs when the communication is lost from the control to the display.	Check for loose connections and proper pin alignment/engagement on the Control's plug.	Check for continuity on the wire harness from the display to the control. See repair parts section for proper replacement part.
		Cycle power off and on using boiler power switch and check for operation.	Replace with new display module. See repair parts section for proper replacement part.

7.2 Suggested Corrective Actions (continued)

Fault	Condition	Diagnostic	Corrective Action(s)
TEMPERATURE SENSOR	Occurs when a temperature sensor has electrically shorted (SHORT) or has become disconnected (OPEN).	Reset using manual reset screen on control panel. (Power button)	Check all the temperature readings of the boiler on the DIAGNOSTICS - TEMPERATURES menu to determine if any sensors are currently displayed as SHORT or OPEN.
			Check wire harness for loose connections and pin engagement at sensor Connection and Control module.
			If problem persists after checking items above replace Control. Refer to repair parts section for kit number.
FLAME FAULT	Occurs when flame is detected when there should be no flame.	Reset using manual reset screen on control panel. (Power button)	Burner may be operating too hot due to incorrect combustion. Inspect flame and conduct combustion test.
			Check for flame at burner via flame current with burner off. Turn boiler off and watch flame through observation port. If flame continues after shutdown replace gas valve.
BLOWER FAULT	Blower unable to reach required speed or does not reach 0 RPM when turned off.	Reset using manual reset screen on control panel. (Power button)	Check wire harness for loose connections and pin engagement at blower. Connections.
			Boiler in standby mode and blower not running. If BLOWER SPEED is not 0 RPM then replace blower.
			If blower does not rotate during ignition sequence check for 120V power at blower connection. If 120Vac power at blower motor and it doesn't start replace blower. Check power at Control. If 120Vac is not present at Control when boiler is powered replace Control.
IGNITION FAULT	Even if boiler went through 8 ignition attempts, but cannot detect flame	Power off and on.	Dirty burner and/or heat exchanger will cause high back pressure and poor ignition. Visual inspection of flue ways often will not be able to diagnose condition.
			Check incoming gas pressure with boiler off and at Max fire. Adjust within limits on rating label.
			Check for flue pipe and intake pipe restrictions or blockage
			Check burner fasteners and gaskets
GAS VALVE FAULT	The Control has detected a problem with it gas valve output circuit.	Reset using manual reset screen on control panel. (Power button)	Check wire harness connections between gas valve and Control.
			If lockout re-occurs replace Control.

this page intentionally left blank.

SECTION 8 Maintenance

8.1 Annual startup & general maintenance

■ Regular Maintenance

- This Manual should be placed in a safe and dry location near the Combination boiler. Maintenance instructions should be carried out by the following guidelines.

■ Maintenance procedures [Daily]

- **Check that the boiler front cover is closed.**
The front cover must be installed with both top latches tightened while the boiler is in operation.

WARNING

To prevent potential severe personal injury, death or substantial property damage, remove all contaminants or contaminated materials immediately from the area around the boiler. If exposed to contaminated materials, call a qualified service technician to inspect the boiler for possible damage from acid corrosion.

WARNING

DO NOT store combustible materials, gasoline or any other flammable vapors or liquids near the Boiler. Remove them immediately or store them other places.

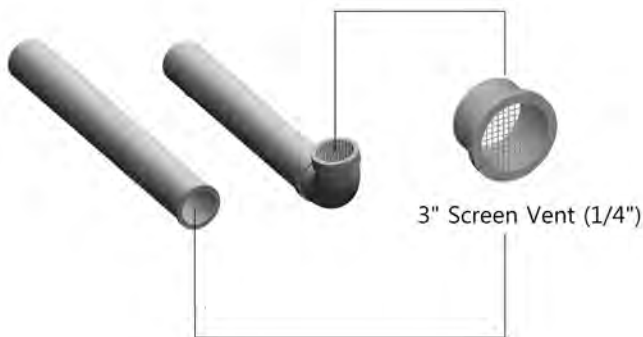

- Check the power source.

Make sure that the power cord is correctly connected. The main power line is connected to the manual switch box inside a combination boiler. (Power line through the strain relief in the bottom of the combination boiler casing and fix it.)

- Check the status of the control panel

Check status of the power supply. Please check for any debris on the button.

■ Maintenance procedures [Monthly]

- Check the vent pipe.

Visually inspect the flue gas vent piping for detecting any signs of blockage, leakage or deterioration of the piping. Please contact a qualified service technician immediately if you find any problem.

- Check the air inlet pipe.

Visually inspect the air inlet piping and combustion. Inspect entire length of air piping for ensuring that piping is intact and all joints are properly sealed. To remove the combustion air filter (located on the left pipe), remove 2 holding screws and carefully slide out filter assembly. Clean thoroughly and put back in. Make sure no debris fell into the boiler. Call your qualified service technician if you notice any problems.

- Check the relief valve.

Inspect the Combination boiler relief valve and the relief valve discharge pipe for any signs of weeping or leakage. If the relief valve often weeps, immediately contact your qualified service technician for inspecting the Combination boiler and system.

- Check the condensate outlet.

While the Combination boiler is running, check the discharge end of the condensate drain tubing. Make sure that no flue gas is escaping from the condensate drain tubing. If flue gas is continuously escaping, it is a serious problem. Shut off the boiler and immediately. Call your qualified service technician for inspecting the Combination boiler and condensate line. Also, refill the condensate trap if problem persists regularly.

- Check the vent terminal screen vent (rodent screen).

If you encounter a problem of combustion performance, visually inspect the terminal screen. And then replace it with spare parts or clean the screens.

- Check the air vent

If the air vent valve seems to work freely without leaking, close cap A fully. Loosen cap “A” one turn to allow vent to operate. If vent does not operate correctly, replace the vent.

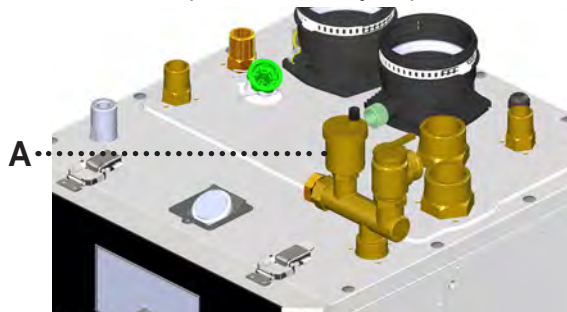

seat. If the valve continues to weep, contact your qualified service technician for inspecting the valve and system. If water does not flow from the valve even though you have lifted the lever completely, the valve or discharge line may be blocked. Shut down the Combination boiler immediately. Call your qualified service technician to inspect the combination boiler and system.

- Check the burner state

You can clean the exterior of burner with a vacuum hose or dry cloth.. However, if you need to clean the inside of the burner stage, you should call a qualified service technician.

■ Maintenance procedures [Every 6 Months]

- Check the boiler piping (gas and water)

Visually inspect for leaks around internal water piping. Also inspect external water piping, circulators, relief valve and fittings. Immediately call a qualified service technician to repair any leaks. Leaks must be repaired by a qualified service technician immediately.

Failure to comply with this instruction could result in severe personal injury, death or substantial property damage.

- Check the pressure relief valve

! WARNING

Leaks must be fixed by a qualified service technician immediately. Failure to comply with this instruction could result in severe personal injury, death or substantial property damage. This discharge line must be installed by a qualified heating installer or a service technician.

Before proceeding, verify that relief valve outlet has been piped to a safe place of discharge within 6 to 12” from a suitable floor drain, avoiding any possibility of scalding from hot water. If water flows freely, release the lever and allow the valve to seat. Watch the end of the relief valve discharge pipe to ensure that the valve does not weep after the line has had time to drain. If the valve weeps, lift the seat again to attempt to clean the valve

8.2 Flushing the Combination Boiler

Flushing the DHW Heat Exchanger is a complicated procedure that should only be done by an authorized technician or licensed professional. Keep in mind that improper maintenance can void your warranty.

1. Disconnect electric power to the combination boiler.
2. It is highly recommended to have 3/4" service and isolation valves installed on both DHW lines.
3. Connect hose "D1" to the valve "V3" and place the free end in the bucket. Connect hose "D3" to the circulation pump outlet and the cold water inlet line at the valve "V4". Connect hose "D2" to the circulation pump inlet and place the free end in the bucket.
4. Pour the cleaning solution into the bucket. Place the drain hose (D1) and the hose (D2) to the pump inlet into the cleaning solution.
5. Open service valves (V3 & V4) on the hot water outlet and cold water inlet lines.
6. Turn on the circulation pump (Operate the pump and allow the cleaning solution to circulate through the combination boiler for at least 1 hour at a rate of 4 gallons per minute.)
7. Rinse the cleaning solution from the combination boiler as follows:
 - Remove the free end of the drain hose (D1) from the bucket.
 - Close service valve, (V4), and open shut off valve, (V2).
Do not open shut off valve, (V1).
 - Allow water to flow through the combination boiler for 5 minutes.
 - Close shut off valve (V2).
8. Ensure service valves are closed (V3 and V4) and shut off valves are open (V1 and V2).
9. Disconnect all hoses.
10. Open top left access panel and have a few towels available to mop up any water.
11. Remove the cold water inlet filter from the combination boiler and clean out any residues.
12. Reinsert the filter and ensure the filter cap is securely tightened. Reinstall top left access panel.
13. Connect electrical power to the combination boiler.

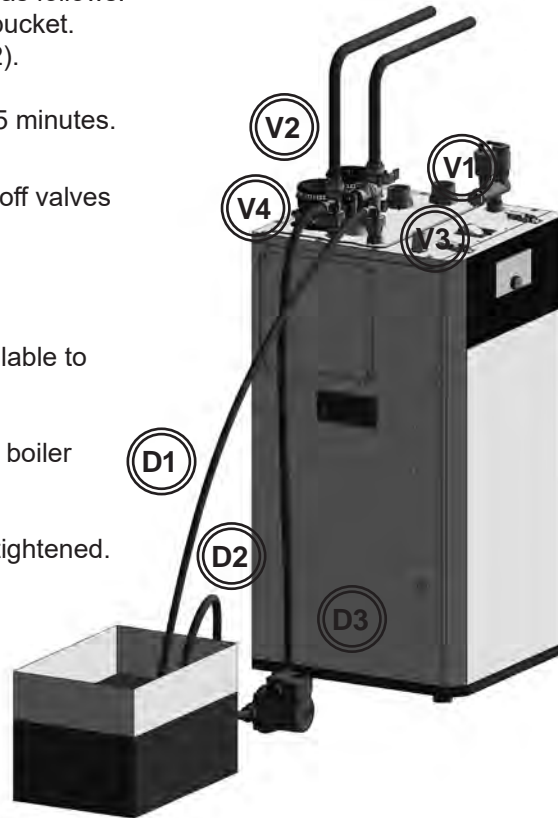
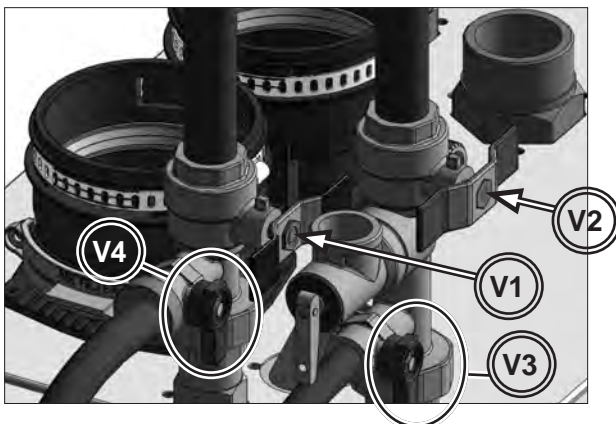

8.3 Draining and Cleaning

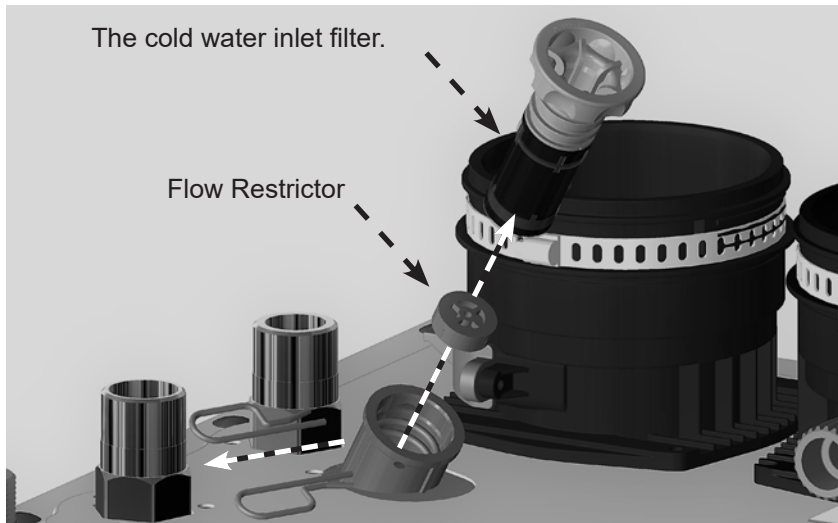

FTCF199



1. Disconnect electrical power to the combination boiler.
2. Close the external manual gas shut-off valve near the appliance. Remove top left access panel. Have a few towels handy to mop up any water.
3. Close water supply valve on the inlet to the appliance. If there is no valve, turn off main water valve.
4. Open the hot water faucets completely.
5. Remove the Cold Water Inlet filter by removing the two small pins and then pulling the filter upward at an angle. If your system is using a flow restrictor, be sure that the flow restrictor is also cleaned and placed back into the system during re-assembly.
6. Clean them with a toothbrush and clean running water.
7. To refill the combination boiler, reassemble the filters back into the combination boiler and reverse steps 5 back to 1.

8.4 Freeze Protection

FT Boilers are certified for indoor use only, and are not design-certified for placement outdoors. Proper precautions for freeze protection are recommended for boiler installations in areas where the danger of freezing exists.

Power outage, interruption of gas supply, failure of system components, activation of safety devices, etc., may prevent a boiler from firing. **Any time a boiler is subjected to freezing conditions, and the boiler is not able to fire, and/or the water is not able to circulate, there is a risk of freezing in the boiler or in the pipes in the system.** When water freezes, it expands which may result in bursting of pipes, or damage to the boiler, which could result in leaking or flooding conditions.

⚠ NOTICE

Different glycol products may provide varying degrees of protection. Glycol products must be maintained properly in a heating system, or they may become ineffective. Consult the glycol specifications, or the glycol manufacturer, for information about specific products, maintenance of solutions, and set up according to your particular conditions.

⚠ NOTICE

Not all pumps are capable of maintaining the reduced temperature rise required with glycol concentrations greater than 35%.

Freeze Protection (continued)

WARNING

Do NOT use automotive antifreeze or ethylene glycol. Use only inhibited propylene glycol solutions which are specially formulated for hydronic systems. Ethylene glycol is toxic and can attack gaskets, seals, and metallic components used in hydronic systems. A correct glycol concentration and inhibitor level is critical.

Some items to consider are

- Consider the effects of reduced heat transfer and an increase in head pressure against the system circulator. For example: A 30% mixture of glycol will result in a BTU output loss of 15% with a 5% increase in head against the system circulator.
- Glycol mixtures should not exceed 40%. A 50% mixture of glycol will result in a BTU output loss of 30% with a 50% increase in head against the system circulator. Glycol concentrations above 40% by volume can lead to short cycling of the burner.
- The glycol solution should be tested as recommended by the glycol manufacturer but not less than annually. Some items of concern are pH additive breakdown, inhibitor reduction, etc.
- Glycol/antifreeze solutions expand more than water; therefore, system design must take this into account. For example: a 40% by volume solution expands 4.8% in volume for a temperature increase from 32°F to 180°F, while water expands 3% over the same temperature rise.

CAUTION

It is highly recommended to follow the manufacturers recommended concentrations, expansion requirements, and maintenance recommendations. You must carefully calculate the additional friction loss in the system as well as the reduction in the heat transfer coefficients.

NOTICE

Do not exceed a 40% glycol concentration by volume as it may result in short cycling of the burner.

SECTION 9 Installation Check

9.1 Quick View

- Before Installing
 - Make sure that there is enough space for installing DHW hot and cold, possible DHW recirc, space heating and gas piping.
Verify vent/air termination is located as required.
 - Propane boilers require a propane conversion kit, conversion parts and documentation are included.
- Install Water Piping
 - Boiler loop piping must be sized to the minimums listed in the Boiler manual. Using smaller piping will cause performance problems.(page 34)
- Install Vent & Air Piping
 - Slide the air inlet pipe and vent pipe into the Boiler vent connectors.
 - Make sure the terminations are placed as required in the manual and that air intakes are at least 12 inches above normal snow line.
 - Refer to the material check list in this guide for a list of items needed.
- Install Condensate Piping / Tubing & Components
 - Fill out the material check list in this guide to ensure you have the tubing or PVC pipe and all components needed for the condensate piping.
 - Connect internal components that are supplied with the Boiler.
 - For closet installations, a condensate pump can be placed inside the cabinet. A condensate discharge hose can exit the cabinet either near floor level via provided knock-outs, or via a knock-out in the upper right rear corner of the top panel. Route the 3/8" discharge hose carefully from the top into the boiler cabinet. The condensate pump can be plugged into the electrical outlet located on the inner back panel.
- Install Gas Piping
 - Install a union and shutoff valve.
- Wire the Boiler
 - Connect power wiring and control wiring per boiler manual wiring diagram.(Section 4.19)
- Start up, Adjust & Test
 - Follow the Boiler manual instructions to clean the system if needed, then fill and check water chemistry.

9.2 Final Check Lists

- Final check: Installation Conditions.
 - Is the Boiler placed level on a floor with sufficient strength?
 - Is there a floor drain near the Boiler?
 - Are there any combustible materials near the Boiler and vent pipe?
 - Is the air supply sufficient for proper operation of the Boiler?
 - Are the proper service clearances maintained?
 - Is the distance between the Boiler and point of vent termination minimized?
 - Is the proper distance from windows, doors, and other intake vents maintained?
- Final check: Gas pipe installation
 - Is the gas supply line equipped with a manual shut off valve near the boiler?
 - Is the gas supply line a minimum of 3/4" inner diameter?
 - Is the gas supply line length and diameter adequate to deliver the required BTU's?
 - Has the gas supply line pressure been measured?
 - Does the supply gas type match the type indicated on the boiler rating plate?
- Final check: Air/Vent pipe installation
 - Has the Boiler been vented with 3" or 2" PVC, CPVC, Polypropylene (PP), Stainless Steel or PP Flex
 - Gas Vent (S636 PVC, CPVC) for Category IV appliances in accordance with this manual and/or your local code?
 - Is the vent termination at least 12" above the exterior grade?
 - Is the total vent length within the maximum vent length restriction?
 - Have you checked the air/vent piping for leaks?
 - Have you properly supported the vent termination?
 - Are all vent runs properly supported?
 - Is the vent sloped upward toward the vent termination at a rate of 1/4" per foot (2% grade)?
- Final check: Condensate drain installation
 - Have you installed a condensate drain line from the Boiler to a floor drain or under sink discharge point?
- Final check: Setting the DIP switches
 - Are all DIP switches correctly set on the main board?
 - Have you filled the condensate trap with water or vegetable oil to avoid drying out the trap?
 - When required, have you installed a neutralizer and condensate pump (in or near the boiler) and plugged the condensate pump into an electrical outlet?

- Final check : Connecting the power supply
 - Please check that the power is 120V AC.
 - Have you checked the polarity of the electrical connection?
- Final check : Pressure relief valve
 - Have you properly installed an approved pressure relief valve on the boiler?
 - If applicable, has the DHW pressure relief valve been properly installed. This will be dependent on local codes.
- Final check : Burner flames
 - The burner flame must be checked periodically for a constant proper blue color.
 - If the flame does not appear normal, the burner may need to be cleaned.
 - If the burner needs to be cleaned, it must be performed by a qualified service technician.

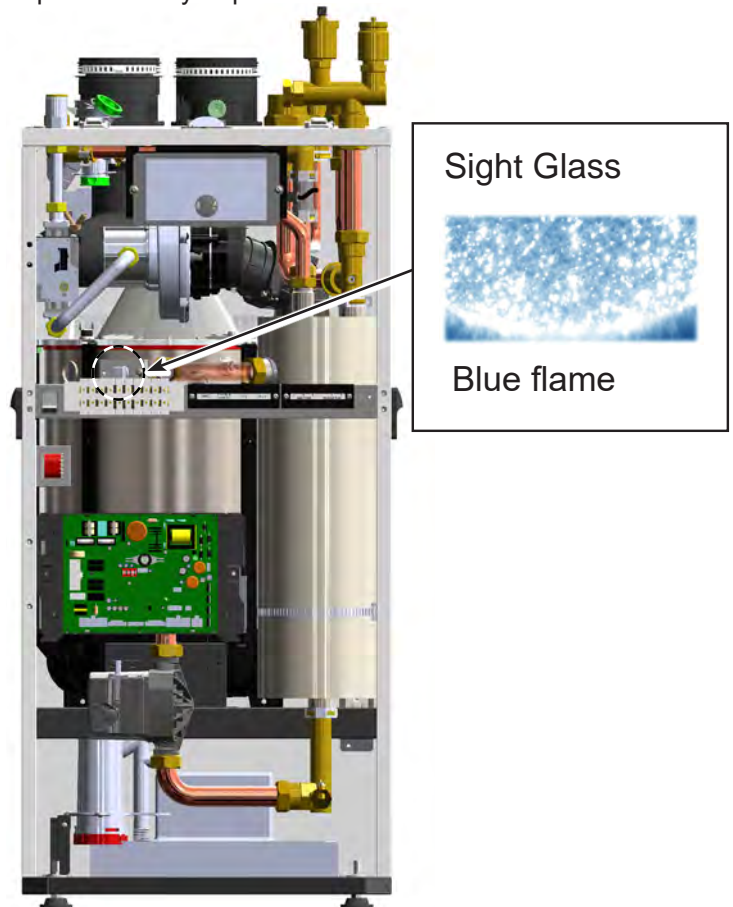

SECTION 10 Parts List and Illustrations

FTCF199 Casing Assembly

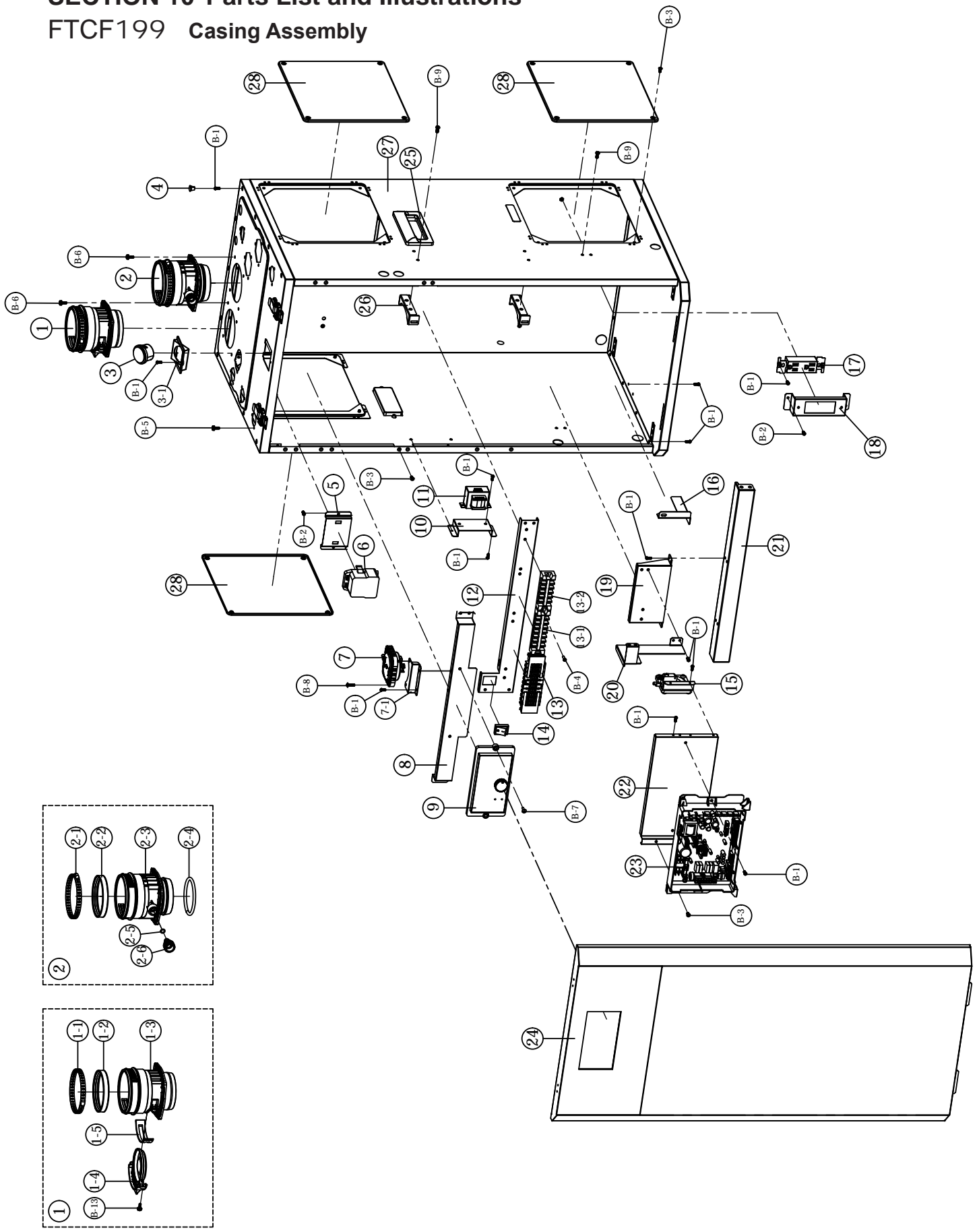

FTCF199 Casing Parts

No.	Description	Part Number
1	Air Intake Collar Ass'y (filter type)	FT3010
1-1	Stainless Band(Ø100)	FT1603
1-2	Packing	FT1604
1-3	3 inch Air Intake Collar	FT3011
1-4	Air Filter	FT3012
1-5	Air Filter Packing	FT3013
B-13	M4 x 14MM Pan Head Screw (coarse thread)	
2	Vent Pipe Collar Ass'y	FT3015
2-1	Stainless Band(Ø100)	FT1603
2-2	Packing	FT1604
2-3	3 inch Vent Pipe Collar	FT3016
2-4	O-Ring P75	FT1609
2-5	O-Ring P7	FT1601
2-6	Exhaust Testing Cap	FT1606
3	CH Pressure Gauge	FT1058
3-1	Pressure Gauge Bracket	FT3017
4	Cover Bolt Cap	FT3018
5	Ignition Transformer Bracket	FT3019
6	Ignition Transformer	FT2031
7	Air Pressure Sensor(80)	FT1804
7-1	Air Pressure Sensor Bracket	FT3136
8	Control Sub Bracket	FT3137
9	Display Control	FT3022
10	Trans Bracket	FT3023
11	Trans (24V)	FT3024
12	Terminal Block Bracket	FT3138
13	Terminal Block(10P)	FT3026
13-1	Terminal Block(8P)	FT2007
13-2	Terminal Block(6P)	FT1827
14	Manual Power Switch	FT1020
15	Blocked Condensate Switch	FT1022
16	Condensate Trap Bracket 2	FT3139
17	Concentric Plug (110V)	FT3028
18	Concentric Plug Bracket (110V)	FT3029
19	Heat Exchanger Sub Bracket	FT3030
20	PCB Control Sub Bracket	FT3031

No.	Description	Part Number
21	Bracket	FT3032
22	PCB Control Bracket	FT3033
23	Main PCB	FT3034
24	Front Cover	FT3140
25	Handle	FT3036
26	Tank bracket	FT3037
27	Casing Ass'y	FT3141
28	AS Cover	FT3039
B-1	M4 x 10MM Pan Head Screw (fine thread)	
B-2	M4 x 12MM Pan Head Screw (fine thread)	
B-3	M4 x 10MM Flat Head Screw (fine thread)	
B-4	M4 x 12MM Pan Head Screw (fine thread)	
B-5	M4 x 8MM Hex Head Screw (fine thread)	
B-6	M4 x 12MM Hex Head Screw (fine thread)	
B-7	M4 x 14MM Pan Head Screw (coarse thread)	
B-8	M4 x 16MM Pan Head Screw (fine thread)	
B-9	M5 x 12MM Washer Head Screw (fine thread)	

FTCF199 Tank and Water Pipe Assembly

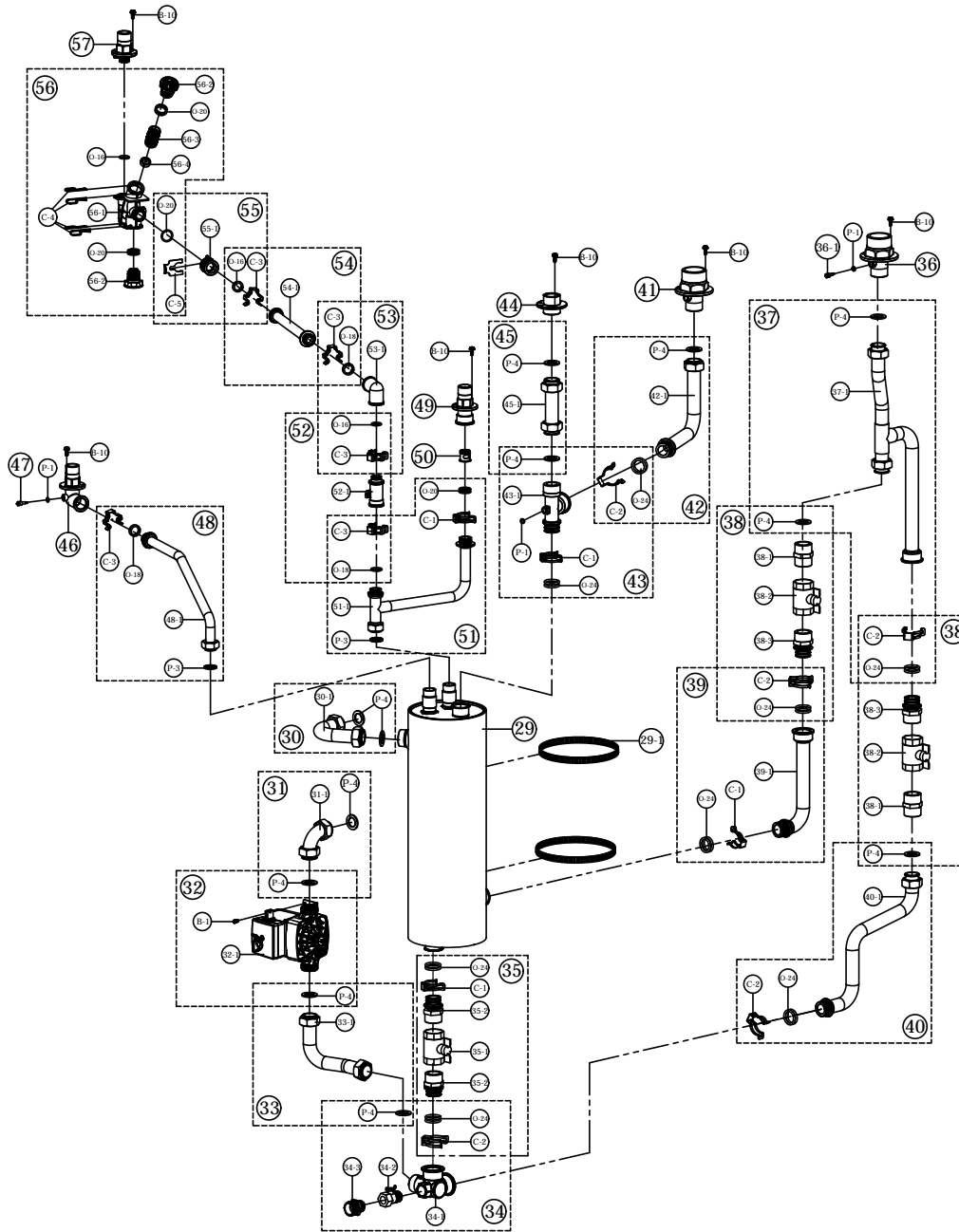

No.	Description	Part Number
29	DHW Water Tank Ass'y	FT3142
29-1	Stainless Band (Ø165)	FT1813
30	Internal Circulation Pipe 1 Ass'y	FT3069
30-1	Internal Circulation Pipe 1	
P-4	1" Packing	FT1691
31	Internal Circulation Pipe 2 Ass'y	FT3047
31-1	Internal Circulation Pipe 2	
P-4	1" Packing	FT1691
32	Boiler Pump Ass'Y	FT3049
32-1	Boiler Pump	
P-4	1" Packing	FT1691
B-1	M4 x 10MM Pan Head Screw (fine thread)	

No.	Description	Part Number
33	Pump Bottom Pipe Ass'y	FT3143
33-1	Pump Bottom Pipe	
P-4	1" Packing	FT1691
34	CH Return 3way Adapter Ass'y	FT3145
34-1	Return 3way Adapter	
34-2	Ball Valve	FT1708
34-3	Short brass fitting	FT3055
C-2	Piping Clip2	FT1108
O-24	O-Ring P24	FT3056
P-4	1" Packing	FT1691
35	1" Ball Valve Ass'y 1	FT3147
35-1	1" Ball Valve	FT3148

FTCF199 Tank and Water Pipe Parts

No.	Description	Part Number
35-2	Ball Valve Adapter	FT3149
C-1	Piping Clip1	FT1107
C-2	Piping Clip2	FT1108
O-24	O-Ring P24	FT3056
36	CH Return Connection	FT3059
36-1	CH Return Sensor	FT1635
P-1	3/8" Packing	FT3062
37	CH Return Top Pipe Ass'y	FT3150
37-1	CH Return Top Pipe	
P-4	1" Packing	FT1691
C-2	Piping Clip2	FT1108
O-24	O-Ring P24	FT3056
38	1" Ball Valve Ass'y 2	FT3152
38-1	1" Short brass fitting	FT3153
38-2	1" Ball Valve	FT3154
38-3	Ball Valve Adapter	FT3155
P-4	1" Packing	FT1691
C-2	Piping Clip2	FT1108
O-24	O-Ring P24	FT3056
39	CH Return bottom Pipe 1 Ass'y	FT3156
39-1	CH Return bottom Pipe 1	
C-1	Piping Clip1	FT1107
C-2	Piping Clip2	FT1108
O-24	O-Ring P24	FT3056
40	CH Return bottom Pipe 2 Ass'y	FT3158
40-1	CH Return bottom Pipe 2	
P-4	1" Packing	FT1691
O-24	O-Ring P24	FT3056
C-2	Piping Clip2	FT1108
41	CH Supply Connection	FT3065
42	CH Supply Pipe Ass'y	FT3063
42-1	CH Supply Pipe	
P-4	1" Packing	FT1691
O-24	O-Ring P24	FT3056
C-2	Piping Clip2	FT1108
43	3way Connection Ass'y	FT3060
43-1	3way Connection	
P-1	3/8" Packing	FT3062
P-4	1" Packing	FT1691
O-24	O-Ring P24	FT3056
C-1	Piping Clip1	FT1107
C-2	Piping Clip2	FT1108
44	Adapter Connection	FT3068
45	Adapter Pipe Ass'y	FT3066
45-1	Adapter Pipe	
P-4	1" Packing	FT1691
46	DHW Outlet Connection	FT3073
47	DHW Outlet Sensor	FT1638

No.	Description	Part Number
P-1	3/8" Packing	FT3062
48	DHW Outlet Pipe Ass'y	FT3071
48-1	DHW Outlet Pipe	
O-18	O-Ring P18	FT1687
C-3	Flow Sensor Clip	FT1208
P-3	3/4" Packing	FT1646
49	Recirculation Connection	FT3077
50	Check Valve	FT3078
51	DHW Inlet Pipe2 Ass'y	FT3074
51-1	DHW Inlet Pipe2	
P-3	3/4" Packing	FT1646
O-18	O-Ring P18	FT1687
O-20	O-Ring P20	FT1513
C-1	Piping Clip1	FT1107
C-3	Flow Sensor Clip	FT1208
52	Flow Sensor Ass'y	FT3076
52-1	Flow Sensor	
C-3	Flow Sensor Clip	FT1208
O-16	O-Ring P16	FT1643
O-18	O-Ring P18	FT1687
53	Elbow Connection Ass'y	FT3079
53-1	Elbow Connection	
O-16	O-Ring P16	FT1643
O-18	O-Ring P18	FT1687
C-3	Flow Sensor Clip	FT1208
54	DHW Inlet Pipe Ass'y	FT3081
54-1	DHW Inlet Pipe	
O-16	O-Ring P16	FT1643
O-18	O-Ring P18	FT1687
C-3	Flow Sensor Clip	FT1208
55	Inlet Pipe Adapter Ass'y	FT3083
55-1	Inlet Pipe Adapter	
C-5	Adapter Clip	FT3085
O-16	O-Ring P16	FT1643
O-20	O-Ring P20	FT1513
C-3	Flow Sensor Clip	FT1208
56	DHW Filter Body Ass'y	FT3086
56-1	DHW Filter Body	
56-2	Block Cap	FT1121
56-3	DHW Filter Mesh	FT1120
56-4	Flow restrictor	FT1822
O-16	O-Ring P16	FT1643
O-20	O-Ring P20	FT1513
C-4	R Clip	FT1524
C-5	Adapter Clip	FT3085
57	DHW Inlet Connection	FT3088
B-10	M5 x 10MM Hex Head Screw (fine thread)	

FTCF199 Heat Exchanger and Tank Assembly

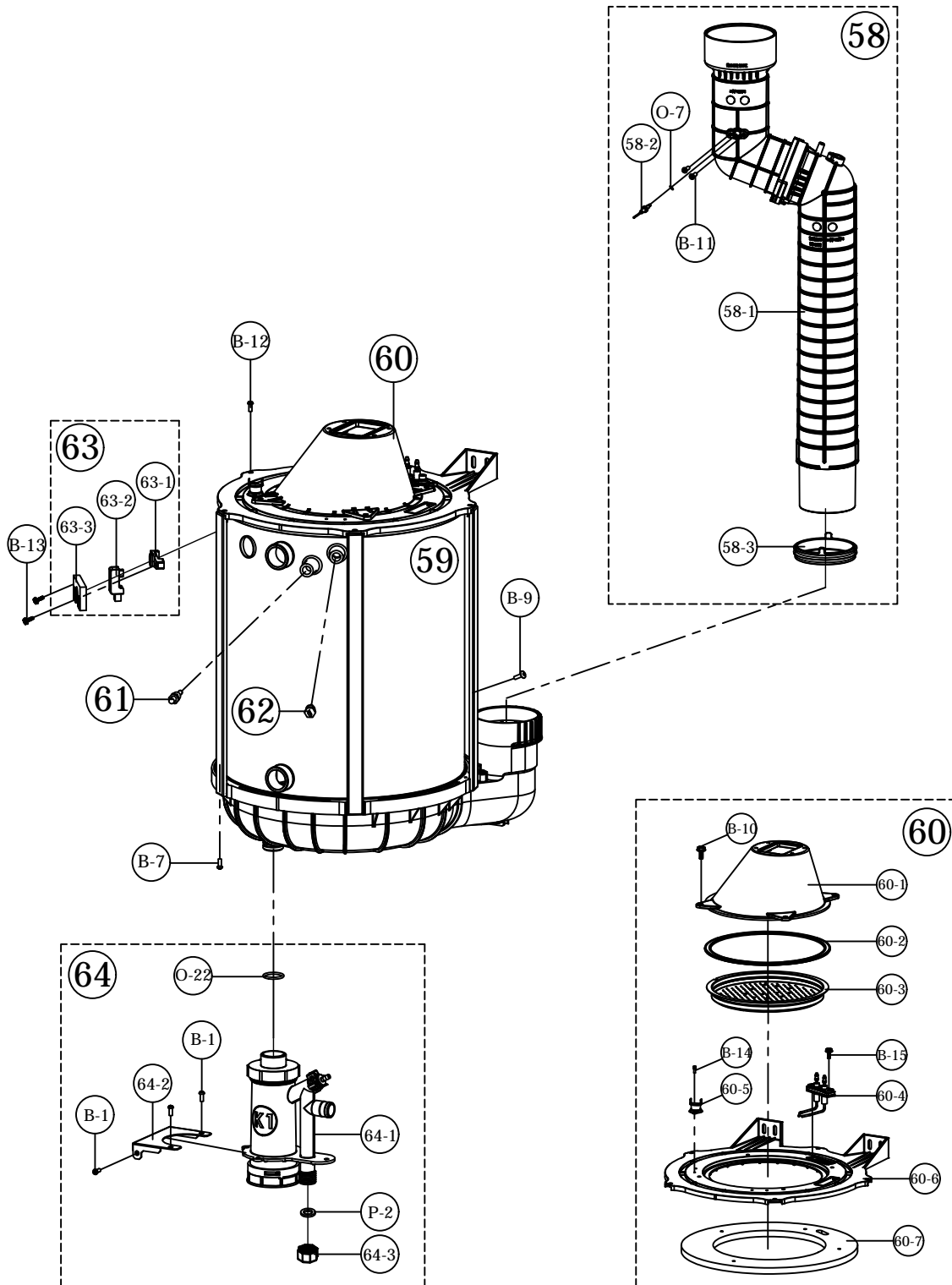

FTCF199 Heat Exchanger and Tank Parts

No.	Description	Part Number
58	Exhaust Duct Ass'y	FT3090
58-1	Exhaust Duct	
58-2	Exhaust Overheat Sensor	FT1307
58-3	Exhaust Duct Packing (Lower)	FT2036
O-7	O-Ring P7	FT1601
B-11	M4 x 9MM Hex Head Screw (coarse thread)	
59	Heat Exchanger Ass'y	FT3093
60	Burner Ass'y	FT3094
60-1	Burner Upper Case	FT1760
B-10	M5 x 10MM Hex Head Screw (fine thread)	
60-2	Burner Packing	FT1824
60-3	Burner	FT1838
60-4	Ignition Rod Ass'y	FT3127
B-15	M4 x 14MM Socket Head Cap Screw (fine thread)	
60-5	Overheat Sensor	FT1310
B-14	M3 x 6MM Socket Head Cap Screw (fine thread)	
60-6	Burner Downside Case	FT2041
60-7	Refractory	FT3095
B-10	M5 x 10MM Hex Head Screw (fine thread)	
61	Overheat Temperature Sensor	FT1324
62	Low Water Cut off Sensor	FT1325
63	Flame Detecting Sensor Ass'y	FT2085
63-1	Flame Detecting Sensor Bracket	FT1669
63-2	Flame Detecting Sensor	FT1327
63-3	Flame Detecting Sensor Cover	FT1069
B-13	M4 x 14MM Pan Head Screw (coarse thread)	
64	Condensate Trap Sub Ass'y	FT3098
64-1	Condensate Trap Ass'y	
64-2	Condensate Trap Bracket 1	FT3160
64-3	Condensate Trap Cap	FT3101
O-22	O-Ring P22	FT1644
P-2	1/2" Packing	FT1875
B-7	M4 x 14MM Pan Head Screw (coarse thread)	
B-9	M5 x 12MM Washer Head Screw (fine thread)	
B-12	M5 x 16MM Pan Head Screw (fine thread)	

FTCF199 Fan and Gas Valve Parts

No.	Description	Part Number
65	Fan Guide Ass'y	FT2087
65-1	Fan Guide	
65-2	Fan Rubber Packing #2	FT2020
65-3	Damper Body Ass'y	FT2044
65-4	Fan Guide Packing	FT1772
66	Fan Ass'y	FT3128
66-1	Fan	
66-2	Fan Sealing O-Ring	ST1038
66-3	AGM Venturi	FT1917
66-4	AGM O-Ring	FT1774
66-5	AGM Body	FT1775
B-17	M4 x 8MM Pan Head Screw (fine thread)	
67	Air Intake Hose Ass'y	FT3105
67-1	Air Intake Hose	
67-2	Stainless Band 1 (Ø90)	FT3107
67-3	Stainless Band 2 (Ø89)	FT1777
67-4	Nylon Barb Y Fitting	FT1918
68	Gas Valve Ass'y	FT3108
68-1	Gas Valve Inlet Adaptor	FT1538
68-2	Gas valve O-ring	FT1727
68-3	Gas valve bracket	FT3109
68-4	Gas Valve	FT1416
68-5	Gas Valve Outlet Adaptor	FT1919
B-17	M4 x 10MM Pan Head Screw (fine thread)	
B-18	M4 x 12MM Pan Head Screw (fine thread)	
69	Gas Inlet Adaptor	FT3110
70	Gas Inlet Pipe 1 Ass'y	FT3111
70-1	Gas Inlet Pipe 1	
P-5	1/2" Spiral Packing	FT1710
71	Gas Inlet Pipe 2 Ass'y	FT3113
71-1	Gas Inlet Pipe 2	
P-5	1/2" Spiral Packing	FT1710
72	Nozzle(natural)	FT1780
-	Nozzle(propane)	FT1802
B-18	M5 x 12MM Hex Head Screw (fine thread)	
B-19	M5 x 14MM Hex Head Screw (fine thread)	

The FT Series Floor Standing, Combination Boiler

FTCF199 Accessory Items

No.	Description	Part Number
1	Pressure Relief Valve	FT1500
2	Air Vent	FT3117
3	Brass Adaptor	FT3118
4	3/4" Brass Plug	FT3119
5	Recirculation Brass Plug	FT3120
6	Outdoor Temp. Sensor	FT1501
7	Mixing Valve	V20331
8	Bird Screens 3" (Qty 2)	FT1730
9	Spare Parts Kit	FT3161
10	Condensate Hose	ST1070
11	Silicone Hose	FT3126
12	Leveling Legs (Qty 4)	FT3122
13	Gas conversion kit	FT3123
14	Flow restrictor	FT1506
15	Wire Harness (optional)	FT3162
16	DHW Recirc. Sensor (optional)	FT1868

Dimensions and specifications subject to change without notice in accordance with our policy of continuous product improvement.



H2420500-