

Installation and Operation  
Instructions for  
**Low Temperature**  
**PENNANT™**

Hydronic Boiler  
Model PNCH  
Water Heater  
Model PNCV

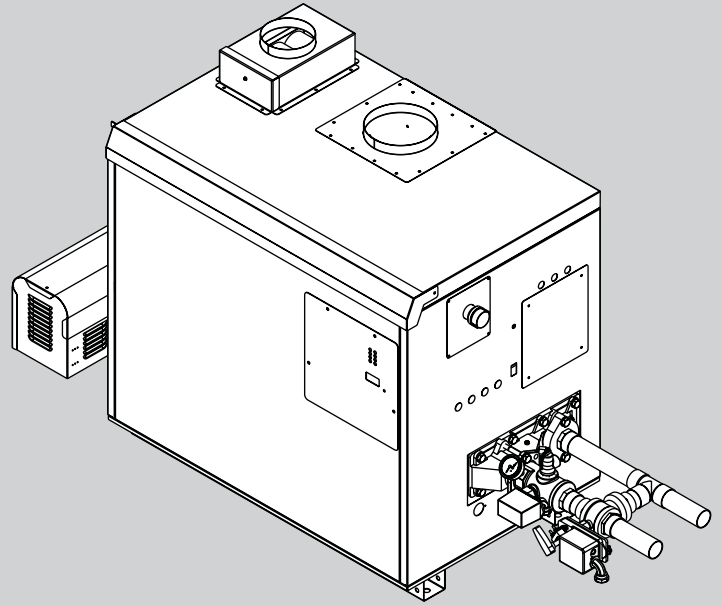

**FOR YOUR SAFETY:** This product must be installed and serviced by a professional service technician, qualified in hot water boiler installation and maintenance. Improper installation and/or operation could create carbon monoxide gas in flue gases which could cause serious injury, property damage, or death. Improper installation and/or operation will void the warranty. For indoor installations, as an additional measure of safety, Laars strongly recommends installation of suitable Carbon Monoxide detectors in the vicinity of this appliance and in any adjacent occupied spaces.

**⚠ WARNING**

If the information in this manual is not followed exactly, a fire or explosion may result causing property damage, personal injury or loss of life.

Do not store or use gasoline or other flammable vapors and liquids in the vicinity of this or any other appliance.

**WHAT TO DO IF YOU SMELL GAS**

- Do not try to light any appliance.
- Do not touch any electrical switch; do not use any phone in your building.
- Immediately call your gas supplier from a nearby phone. Follow the gas supplier's instructions.
- If you cannot reach your gas supplier, call the fire department.

Installation and service must be performed by a qualified installer, service agency, or gas supplier.

**⚠ AVERTISSEMENT**

Assurez-vous de bien suivre les instructions données dans cette notice pour réduire au minimum le risque d'incendie ou d'explosion ou pour éviter tout dommage matériel, toute blessure ou la mort.

Ne pas entreposer ni utiliser d'essence ni d'autres vapeurs ou liquides inflammables dans le voisinage de cet appareil ou de tout autre appareil.

**QUE FAIRE SI VOUS SENTEZ UNE ODEUR DE GAZ:**

- Ne pas tenter d'allumer d'appareils.
- Ne touchez à aucun interrupteur. Ne pas vous servir des téléphones dans le bâtiment où vous trouvez.
- Appelez immédiatement votre fournisseur de gaz depuis un voisin. Suivez les instructions du fournisseur.
- Si vous ne pouvez rejoindre le fournisseur de gaz, appelez le service des incendies.

L'installation et l'entretien doivent être assurés par un installateur ou un service d'entretien qualifié ou par le fournisseur de gaz.

## TABLE OF CONTENTS

### SECTION 1. General Information

1.1	Introduction .....	3
1.2	Model Identification .....	4
1.3	Warranty .....	4
1.4	Dimensions .....	4
1.5	Locating the Appliance.....	4
1.6	Locating Pump-Mounted Water Heater with Respect to Storage Tank(s).....	6
1.7	Locating Pump-Mounted Boiler with Respect to Return/Supply Header.....	6
1.8	Locating Appliance for Correct Horizontal Vent/Ducted Air Distance From Outside Wall .....	6

### SECTION 2. Venting and Combustion Air

2.1	Combustion Air .....	7
2.1.1	Combustion Air From Room .....	7
2.1.2	Intake Combustion Air.....	7
2.2	Venting.....	8
2.2.1	Vent Categories .....	8
2.2.2	Category I Vent.....	8
2.2.3	Common Venting Systems .....	8
2.2.4	Category III Vent.....	9
2.3	Locating Vent & Combustion Air Terminals.....	9
2.3.1	Side Wall Vent Terminal.....	9
2.3.2	Side Wall Combustion Air Terminal.....	12
2.3.3	Vertical Vent Terminal .....	12
2.3.4	Vertical Combustion Air Terminal .....	12
2.4	Common Vent Test – Boilers .....	12
2.5	Vent Terminals for Outdoor Units.....	13

### SECTION 3. Gas Supply and Piping

3.1	Gas Supply and Piping .....	14
-----	-----------------------------	----

### SECTION 4A.

#### Water Connections – Pennant Boiler

4A.1	Heating System Piping: Hot Supply Connections – Boiler .....	16
4A.2	Cold Water Make-Up – Boiler .....	16
4A.3	Water Flow Requirements – Boiler .....	16
4A.4	Freeze Protection – Boiler .....	16

#### SECTION 4B. Water Connections – Pennant Water Heater

4B.1	Water System Piping – Water Heater .....	17
4B.2	Hot Water Supply Piping – Water Heater .....	17
4B.3	Water Flow Requirements – Water Heater .....	17
4B.4	Combined Water (potable) Heating and Space Heating.....	17
4B.5	Freeze Protection – Water Heater .....	17

### SECTION 5. Electrical Connections

5.1	Main Power.....	20
5.1.1	Sizes 500-1500.....	21
5.1.2	Sizes 1750-2000.....	21
5.1.3	Separate Pump Circuit.....	21
5.1.4	All Sizes.....	21
5.2	Field Wiring .....	21
5.3	Low Water Cut-Off .....	22

### SECTION 6. Operating Instructions

6.1	Filling the Boiler System .....	28
6.2	Sequence of Operation.....	28
6.3	Temperature (Operating) Control.....	29
6.3.1	Temperature Control Overview .....	29
6.3.2	Programming Parameters-Boilers .....	29
6.3.3	Programming Parameters-Water Heaters .....	30
6.4	Limit Controls.....	30
6.5	Operating the Burner and Set Up .....	30
6.5.1	Set Up for 0 to 2500 Feet Altitude.....	30
6.5.2	High Altitude Adjustment and Set Up.....	31
6.6	Shutting Down the Pennant.....	31
6.7	To Restart the Pennant.....	31

### SECTION 7. Maintenance

7.1	System Maintenance .....	32
7.2	Appliance Maintenance and Component Description .....	32
7.2.1	Burners .....	32
7.2.2	Filter.....	33
7.2.3	Gas Valves.....	33
7.2.4	Manual Reset High Limit Control.....	33
7.2.5	Automatic Reset High Limit Control.....	33
7.2.6	Temperature Control .....	33
7.2.7	Ignition Control.....	33
7.2.8	Ignitor.....	34
7.2.9	Transformer .....	34
7.2.10	Blowers.....	34
7.2.11	Flow Switch.....	34
7.2.12	Heat Exchanger Coil.....	34

### SECTION 8. Trouble Shooting

8.1	Resolving Lockouts.....	35
8.2	Delayed Ignition – Possible Causes .....	35
8.3	Short Cycling – Boiler .....	35
8.4	Short Cycling – Water Heater .....	36
8.5	High Gas Consumption.....	36
8.6	Troubleshooting Pennant Controls .....	36

### SECTION 9. Replacement Parts

9.1	General Information .....	36
9.2	Parts List.....	36

## SECTION 1. General Information

**USING THIS MANUAL – Because the Pennant Boilers and Pennant Water Heaters are identical appliances, with the exception of materials of manufacture, labels and ultimate use application, this manual provides information for the proper installation, operation and maintenance of both products. Where differences exist between the application of the appliances and their operation, the sections pertinent to only one appliance or the other will be so identified.**

In the Commonwealth of Massachusetts, this appliance must be installed by a licensed plumber or gas fitter.

### **⚠ WARNING**

To minimize the risk of electric shock, fire or other hazards which could result in property damage, injury, or death. The Pennant hydronic, boiler or water heater **must** be installed in accordance with the procedures detailed in this manual, or the Laars Heating Systems warranty may be voided. The installation must conform to the requirements of the local jurisdiction having authority, and, in the United States, to the latest edition of the National Fuel Gas Code, ANSI Z223.1/NFPA54. In Canada, the installation must conform to the latest edition of the Natural Gas and Propane Installation Code, CSA B149.1 and/or applicable local codes. Where required by the authority having jurisdiction, the installation of Pennant appliances must conform to the Standard for Controls and Safety Devices for Automatically Fired Boilers, ANSI/ASME CSD-1. Any modifications to the boiler, its gas controls, or wiring may void the warranty. If field conditions require modifications, consult the factory representative before initiating such modifications.

### 1.1 Introduction

This manual provides information necessary for the installation, operation, and maintenance of Laars Heating Systems' Low temperature Pennant copper tube appliances, sizes 500-2000 (standard appliances are covered in a separate manual). Read it carefully before installation.

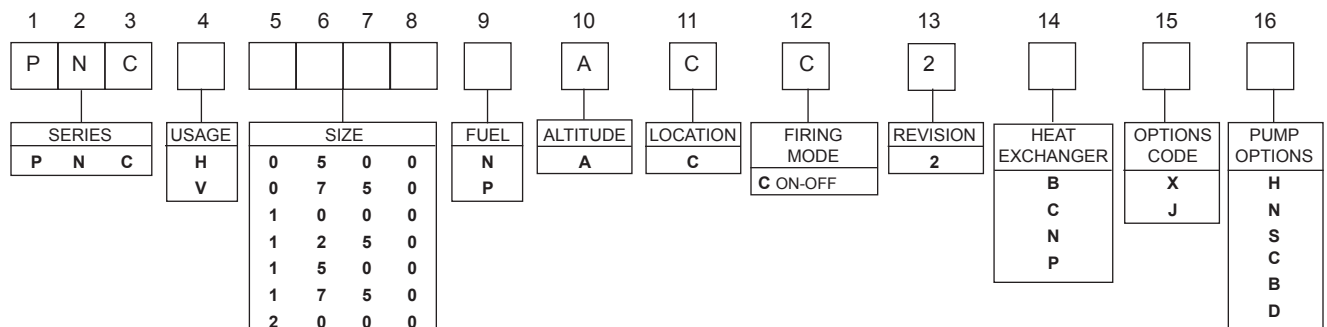

### **⚠ AVERTISSEMENT**

Afin de réduire au minimum les risques de commotion électrique, de feu ou d'autre nature, qui pourraient causer des dommages matériels, des blessures ou des accidents mortels, les chaudières à eau chaude ou les chauffe-eau Pennant **doivent** être installés conformément aux directives détaillées contenues dans ce manuel, à défaut de quoi la garantie fournie par Laars Heating Systems serait annulée. L'installation doit être conforme aux exigences de la réglementation locale en vigueur et, aux États-Unis, à l'édition la plus récente du Natural Fuel Gas Code (Code pour le gaz combustible naturel) ANSI Z223.1/NFPA54. Au Canada, l'installation doit respecter les exigences de la plus récente édition du Code d'installation du gaz naturel et du propane CSA B149.1, et/ou des codes locaux de construction en vigueur. Lorsque la réglementation locale l'exige, l'installation des appareils électroménagers Pennant doit respecter les exigences du Standard for Controls and Safety Devices for Automatically Fired Boilers (Code pour les équipements de commande et de sécurité des chaudières à combustion automatique), ANSI/ASME CSD-1. Toute modification apportée à la chaudière, aux régulateurs de gaz ou au câblage, peut compromettre la garantie. Si certaines conditions particulières rendent des adaptations nécessaires, consulter un représentant du fabricant avant d'entreprendre ces modifications.

All application and installation procedures should be reviewed completely before proceeding with the installation. Consult the Laars Heating Systems factory, or local factory representative, with any issues or questions regarding this equipment. Experience has shown that most operating issues are caused by improper installation.

The Pennant appliance is protected against over pressurization. A pressure relief valve is fitted to all appliances. It is installed on the outlet header, at the water outlet of the appliance.

**IMPORTANT:** The inlet gas pressure to the appliance must not exceed 13 in. w.c. (3.2 kPa).

All installations must be made in accordance with:

- 1) In the U.S., the "National Fuel Gas Code" ANSI Z223.1/NFPA54, Latest Edition and all applicable local codes as required by the Authorities Having Jurisdiction (AHJ), or
- 2) In Canada, the "Natural Gas and Propane Installation Code", CSA B149.1, latest edition and all applicable local codes as required by the AHJ.

All electrical wiring is to be done in accordance with:

- 1). In the U.S., the "National Electrical Code" (NEC), ANSI/NFPA 70, latest Edition and all applicable local codes as required by the AHJ, or
- 2). In Canada, the "Canadian Electrical Code - Part 1", CSA STD. C22.1 and all applicable local codes as required by the AHJ.

This appliance must be electrically grounded in accordance with the applicable codes and standards referenced above.

## 1.2 Model Identification

Consult the rating plate on the unit. The following information describes the model number structure.

### Model Character Designation

#### 1-3 Model Series Designation

P N C = Pennant

#### 4 Usage

H = Hydronic

V = Volume Water

#### 5-8 Size

0 5 0 0 = 500,000 BTU/h input

0 7 5 0 = 750,000 BTU/h input

1 0 0 0 = 999,000 BTU/h input

1 2 5 0 = 1,250,000 BTU/h input

1 5 0 0 = 1,500,000 BTU/h input

1 7 5 0 = 1,750,000 BTU/h input

2 0 0 0 = 1,999,000 BTU/h input

#### 9 Fuel

N = Natural Gas

P = Propane

#### 10 Altitude

A = 0-10,000 feet

#### 11 Location

C = Indoor and Outdoor

#### 12 Firing Mode

C = On-Off

#### 13 Revision

2 = Revision Level 2

#### 14 Heat Exchanger

B = Glass-lined CI / copper / brz trim (std. PNCV)

C = Glass-lined cast iron / copper (std. PNCH)

N = Glass-lined cast iron / cu-nickel

P = Glass-lined cast iron / cu-nickel / brz trim

#### 15 Option Code

X = Standard Low Temp Control

J = CSD-1, FM, IRI, IL

## 16 Pump Options

H = TACO, Hard water pump (PNCV only)

N = TACO, Normal water pump

S = TACO, Soft water pump (PNCV only)

C = B&G, Hard water pump (PNCV only)

B = B&G, Normal water pump

D = B&G, Soft water pump (PNCV only)

## 1.3 Warranty

Laars Heating Systems' appliances are covered by a limited warranty. Owners should submit online warranty registration at [www.Laars.com](http://www.Laars.com).

All warranty claims must be made to an authorized Laars Heating Systems representative, directly to Customer Service, or online at [www.Laars.com](http://www.Laars.com).

Claims must include the serial number and model (this information can be found on the rating plate), installation date, and name of the installer. Shipping costs are not included in the warranty coverage.

Some accessory items are shipped in separate packages. Verify receipt of all packages listed on the packing slip. Inspect everything for damage immediately upon delivery, and advise the carrier of any shortages or damage. Any such claims should be filed with the carrier. The carrier, not the shipper, is responsible for shortages and damage to the shipment whether visible or concealed.

## 1.4 Dimensions

See Figure 1.

## 1.5 Locating the Appliance

The appliance should be located to provide clearances on all sides for maintenance and inspection. It should not be located in an area where leakage of any connections will result in damage to the area adjacent to the appliance or to lower floors of the structure.

When such a location is not available, it is recommended that a suitable drain pan, adequately drained, be installed under the appliance.

The appliance is design certified by CSA-International for installation on combustible flooring; in basements; in closets, utility rooms or alcoves.

**Pennant Boilers or Water Heaters must never be installed on carpeting.** The location for the appliance should be chosen with regard to the vent pipe lengths and external plumbing. The unit shall be installed such that the gas ignition system components are protected from water (dripping, spraying, rain, etc.) during operation and service (circulator replacement, control replacement, etc.). When vented vertically, the Pennant must be located as close as practical to a chimney or outside wall. If the vent terminal and/or combustion air terminal terminate through a wall, and there is potential for snow accumulation in the local area, both terminals should be installed at an appropriate level

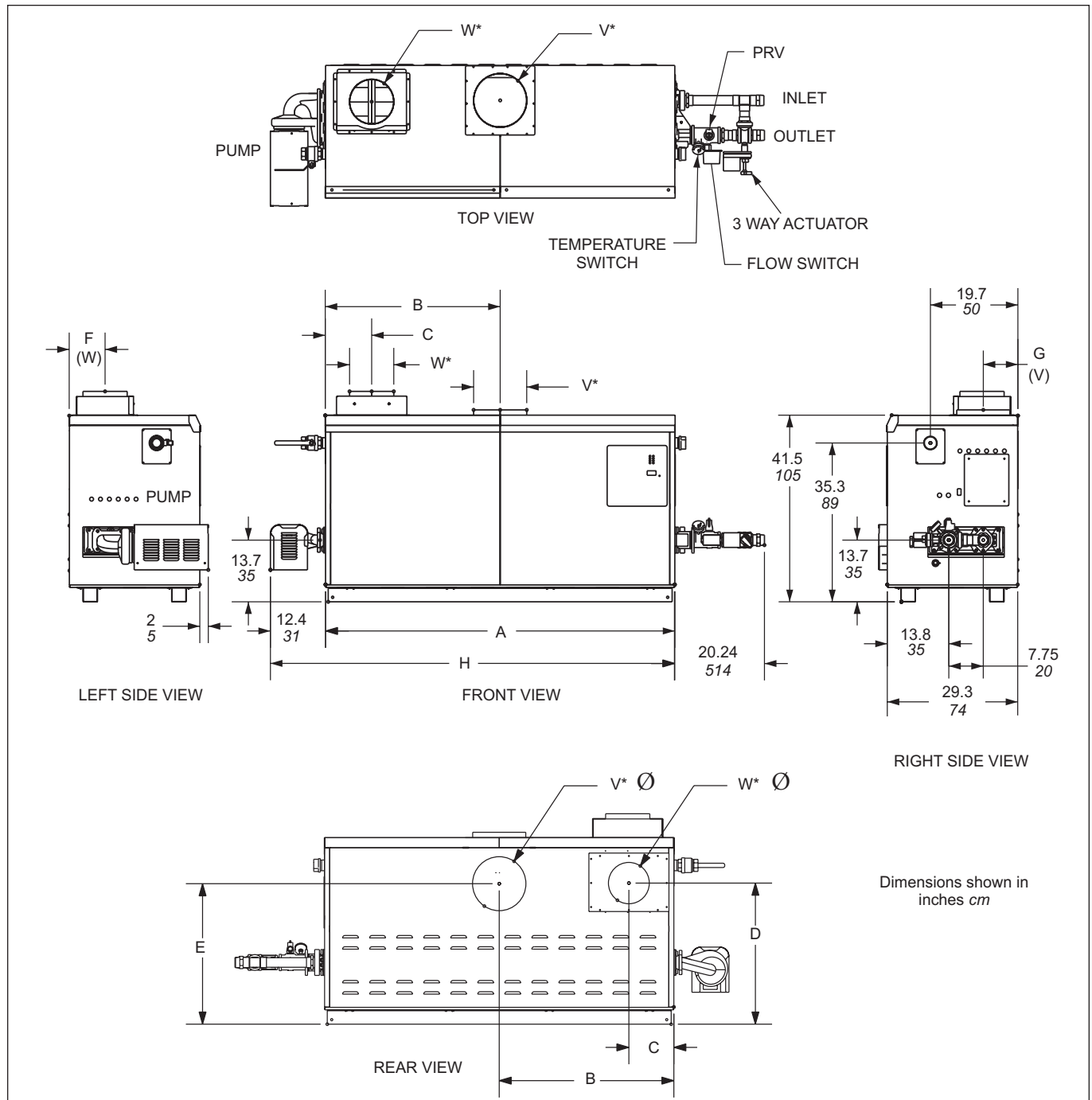

Dimensions shown in inches cm

Size	A		B		C		D		E		F		G		H		Air Conn. W*	Vent Conn. V*	Horiz. Vent Pipe			
500	33½	85	15¾	40	5¾	15	29¾	76	33¾	86	7¾	20	8¾	22	46	117	6	15	8	20	6	15
750	45½	116	21¾	55	5¾	15	29¾	76	33¾	86	7¾	20	8¾	22	58	147	8	20	10	25	8	20
1000	57½	146	28¾	73	5¾	15	29¾	76	33¾	86	7¾	20	7	18	70	178	8	20	10	25	8	20
1250	68	172	34	86	10⅞	26	30¾	78	31⅞	79	8¾	22	8¾	22	80	203	12	30	12	30	8	20
1500	78½	199	39¾	101	10⅞	26	30¾	78	31⅞	79	8¾	22	8¾	22	91	231	12	30	12	30	8	20
1750	89	226	44½	113	10⅞	26	30¾	78	31⅞	79	8¾	22	8¾	22	101	256	12	30	14	36	8	20
2000	99½	253	49¾	126	10⅞	26	30¾	78	31⅞	79	8¾	22	8¾	22	112	284	12	30	14	36	12	30

\*Air and vent connections may be on top or back of the Pennant, and are field convertible.

Dimensions in inches cm

Figure 1. Dimensional Data.

above grade such that blockage of the terminal from accumulated debris or precipitation is prevented.

The dimensions and requirements that are shown in **Table 1** should be met when choosing the locations for the appliance.

### 1.6 Locating Pump-Mounted Water Heater with Respect to Storage Tank(s)

For best results, the Pennant water heater should be located within 15 feet (4.6m) of the storage tank(s). The pump is sized for 30 feet (9.1m) of piping.

If the appliance must be installed with longer piping runs, then larger diameter pipe or tubing may be acceptable. Consult the factory for assistance.

### 1.7 Locating Pump-Mounted Boiler with Respect to Return/Supply Header

For the best results, Pennant should be located within 15 feet (4.6m) of the supply and return headers. The pump is sized for 30 feet (9.1m) of piping.

If the appliance must be installed with longer piping runs, then larger diameter tubing may be acceptable. Consult the factory for assistance.

### 1.8 Locating Appliance for Correct Horizontal Vent/Ducted Air Distance From Outside Wall

The forced draft combustion air blower(s) in the appliance has/have sufficient power to pull air and vent properly when the guidelines for horizontal air and vent are followed (see **Table 2**).

**NOTE:** On some models, the vent collar size is larger than the size of the vent pipe that can be used. Vent collar size and horizontal pipe diameters can be found in Table 1. The larger vent collar size is to accommodate Category I (vertical) vent systems.

**NOTE:** When located on the same wall, the Pennant combustion air intake terminal must be installed a minimum of 12" (30cm) below the exhaust vent terminal and separated by a minimum of 36 inches (91cm) horizontally.

The air intake terminal must be installed high enough to avoid blockage from snow, leaves and other debris.

Appliance Surface	Required Clearance From Combustible Material		Recommended Service Access Clearance	
	inches	cm	inches	cm
Left Side	1	2.5	24	61
Right Side	1	2.5	24	61
Top	1	2.5	12	30
Back	1	2.5	12**	30**
Front	1	2.5	36	91
Vertical (Category 1) Vent	6*	15.2*		
Horizontal (Category 3) Vent	per UL 1738 venting system supplier's instructions			

\*1" (2.5 cm) when b-vent is used.  
 \*\*When vent and/or combustion air connects to the back, recommended clearance is 36" (91cm).

**Table 1. Clearances.**

SIZE	VENT COLLAR SIZE		HORIZONTAL VENT PIPE DIAMETER		INTAKE AIR PIPE DIAMETER		MAX. PIPE LENGTH		MAX. NO. OF ELBOWS	SIDE WALL VENT TERMINAL PART NUMBER	SIDE WALL COMBUSTION AIR TERMINAL PART NUMBER
	in.	cm	in.	cm	in.	cm	ft.	m			
500	8	20	6	15	6	15	50	15	3	CA001401	20260701
750	10	25	8	20	8	20	50	15	3	CA001402	20260703
1000	10	25	8	20	8	20	50	15	3	CA001402	20260703
1250	12	30	10	25	10	25	50	15	3	CA001405	20260705
1500	12	30	10	25	10	25	50	15	3	CA001405	20260705
1750	14	36	12	30	12	30	50	15	3	CA001404	20260706
2000	14	36	12	30	12	30	50	15	3	CA001404	20260706

**Table 2. Horizontal Vent / Combustion Air Parameters.**

## SECTION 2. Venting and Combustion Air

<p><b>⚠ WARNING</b></p> <p>For indoor installations, as an additional measure of safety, Laars strongly recommends installation of suitable Carbon Monoxide detectors in the vicinity of this appliance and in any adjacent occupied spaces.</p>
<p><b>⚠ AVERTISSEMENT</b></p> <p>Pour des installations intérieures, Laars recommande fortement, comme mesure de sécurité supplémentaire, l'installation de détecteurs de monoxyde de carbone adaptés dans le voisinage de l'appareil et dans chacune des pièces habitées adjacentes.</p>

### 2.1 Combustion Air

Pennant boilers and water heaters must have provisions for combustion and ventilation air in accordance with the applicable sections addressing requirements for air for combustion and ventilation of the National Fuel Gas Code, ANSI Z223.1. In Canada, the applicable sections of the Natural Gas and Propane Installation Code (CSA B149.1) must be followed. In all cases any and all applicable local installation codes must also be followed.

A Pennant appliance may receive combustion air from the space in which it is installed, or it can be ducted directly to the unit from the outside. Proper ventilation air must be provided in either case.

#### 2.1.1 Combustion Air From Room

In the United States, the most common requirements specify that the space shall communicate with the outdoors in accordance with method 1 or 2, which follow. Where ducts are used, they shall be of the same cross-sectional area as the free area of the openings to which they connect.

**Method 1:** Two permanent openings, one commencing within 12 inches (30 cm) of the top and one commencing within 12 inches (30 cm) of the bottom, of the enclosure shall be provided. The openings shall communicate directly, or by ducts, with the outdoors or spaces that freely communicate with the outdoors. When directly communicating with the outdoors, or when communicating to the outdoors through vertical ducts, each opening shall have a minimum free area of 1 square inch per 4000 Btu/hr (5.5 square cm/kW) of total input rating of all equipment in the enclosure. When communicating to the outdoors through horizontal ducts, each opening shall have a minimum free area of not less than 1 square inch per 2000 Btu/hr (11 square cm/kW) of total input rating of all equipment in the enclosure. **Table 3** shows data for this sizing method, for each Pennant model.

**Method 2:** One permanent opening, commencing within 12 inches (30 cm) of the top of the enclosure, shall be permitted. The opening shall directly communicate with the outdoors or shall communicate through a vertical or horizontal duct to the outdoors or spaces that directly communicate with the outdoors and shall have a minimum free area of 1 square inch per 3000 Btu/hr (7 square cm/kW) of the total input rating of all equipment located in the enclosure. This opening must not be less than the sum of the areas of all vent connectors in the confined space.

Other methods of introducing combustion and ventilation air are acceptable, providing they conform to the requirements in the applicable codes listed above.

In Canada, consult local building and safety codes or, in absence of such requirements, follow CSA B149.1, the Natural Gas and Propane Installation Code.

#### 2.1.2 Intake Combustion Air

The combustion air can be taken through the wall, or through the roof. When taken from the wall, it must be taken from out-of-doors by means of the Laars horizontal wall terminal (see **Table 2**). When taken from the roof, a field-supplied rain cap or an elbow arrangement must be used to prevent entry of rain water (see **Figure 2**).

Use single-wall galvanized pipe, per **Table 4**, for the combustion air intake (see **Table 2** for appropriate size). Route the intake to the heater as directly as possible. Seal all joints with tape. Provide adequate hangers. The unit must not support the weight of the combustion air intake pipe. Maximum linear pipe length allowed is 50 feet (15.2m). Three elbows have been calculated into the 50-foot (15.2m)

Size	Each Opening*	
	Square inches	Square cm
500	125	807
750	188	1213
1000	250	1613
1250	313	2020
1500	375	2420
1750	438	2826
2000	500	3226

\*Net Free Area in Square Inches / Square cm  
Area indicated is for one of two openings; one at floor level and one at the ceiling, so the total net free area could be double the figures indicated.  
This chart is for use when communicating directly with the outdoors. For special conditions and alternate methods, refer to the latest edition of ANSI Z223.1.  
**Note:** Check with louver manufacturers for net free area of louvers. Correct for screen resistance to the net free area if a screen is installed. Check all local codes applicable to combustion air.

**Table 3. Combustion Air Openings.**

linear run. Subtract 10 allowable linear feet (3.0m) for every additional elbow used (see Table 2). When fewer than 3 elbows are used, the maximum linear pipe length allowed is still 50 feet (15.2m).

The connection for the intake air pipe is on the filter box. Pennant appliances may have venting and combustion air ducting attached to the top or the back. They are shipped with the connections at the top. For attaching either or both pipes to the back, the mounting flanges are reversible by removing the mounting screws and orienting the flanges in the desired position. Replace the screws after positioning flanges. Run a bead of silicone around the collar and slide the pipe over the collar. Secure with sheet metal screws.

In addition to air needed for combustion, air shall also be supplied for ventilation, including all air required for comfort and proper working conditions for personnel. The Pennant loses less than 1 percent of its input rating to the room, but other heat sources may be present.

## 2.2 Venting

### 2.2.1 Vent Categories

Depending upon desired Pennant venting, it may be considered a Category I or a Category III appliance. In general, a vertical vent system will be a Category I system. However, in rare instances, a Pennant's vertical vent system may be considered Category III. In the U.S., the National Fuel Gas Code (ANSI Z223.1), or in Canada the Natural Gas and Propane Installation Code (CSA B149.1), defines a Category I vent system, and includes rules and tables to size these vent systems. If the Pennant's vertical vent system does not satisfy the criteria for Category I venting, it must be vented as a Category III system.

All Pennant vent systems which discharge horizontally (without the use of a power venter) are considered Category III vent systems.

### 2.2.2 Category I Vent

When vented as a Category I appliance, the vent system must conform to the National Fuel Gas Code (ANSI Z223.1-Latest Edition) in the U.S., or in Canada, to the Natural Gas and Propane Installation Code (CSA B149.1 latest edition). The vent system must be sized and installed for a Category I Fan-Assisted Appliance.

If chimney height is greater than 25 feet, or if multiple units are vented into the same vertical vent, a barometric damper must be installed on each appliance, such that the flue draft does not exceed

Term	Description
Pipe	Single-wall galvanized steel pipe, 24 gauge minimum (either insulated or non-insulated)
Joint Sealing	Permanent duct tape or aluminum tape

Table 4. Required Combustion Air Piping Material.

(negative) 0.1 in. w.c.

If using a power venter for any type of Category I venting, the draft should be set between (negative) 0.01 and 0.05 in. w.c.

### 2.2.3 Common Venting Systems

Pennant units are Category I fan-assisted when vented vertically and adhering to all applicable codes. Pennant units are not allowed to be vented into a common horizontal vent system, unless a properly sized vent fan is used, and the common vent system is properly designed by the vent fan manufacturer or a qualified engineer. When common venting Pennant fan-assisted unit with other appliances through one shared vertical duct called a "common vent", special care must be taken by the installer to ensure safe operation. In the event that the common vent is blocked, it is possible, especially for fan-assisted devices, to vent backwards through non-operating appliances sharing the vent, allowing combustion products to infiltrate occupied spaces. **If the appliances are allowed to operate in this condition, serious injury or death may occur.**

#### ⚠ WARNING

Operation of appliances with a blocked common vent may lead to serious injury or death. Safety devices must be implemented to prevent blocked common vent operation. If safe operation of all appliances connected to a common vent cannot be assured, including prevention of spillage of flue gasses into living spaces, common venting should not be applied, and appliances should each be vented separately.

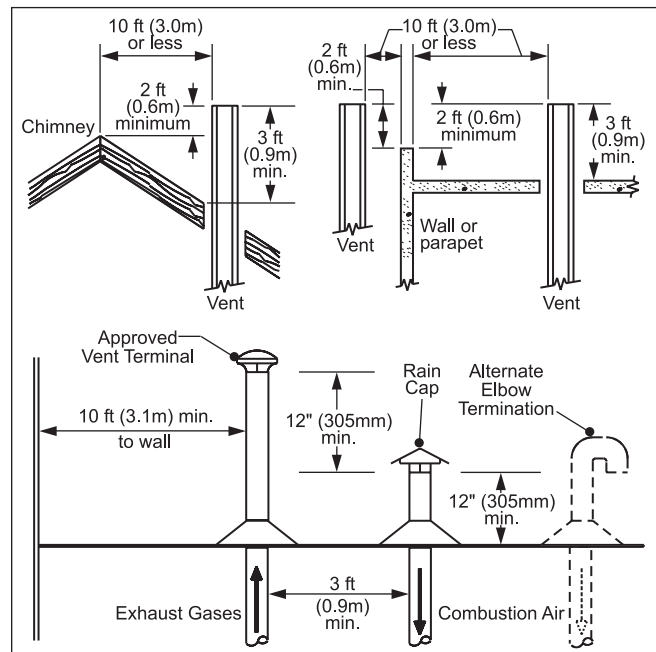

Figure 2. Combustion Air and Vent Through Roof.

**⚠ AVERTISSEMENT**

Le fonctionnement d'appareils connectés à un événement commun bouché peut provoquer de sérieuses blessures corporelles ou la mort. Des dispositifs de sécurité doivent être mis en place pour empêcher que les appareils soient utilisés avec un événement commun bouché. Si un fonctionnement sécuritaire de tous les appareils reliés à un événement commun et si la prévention des dégagements accidentels de gaz de combustion dans des zones habitées ne peuvent pas être assurés, un événement commun ne doit pas être mis en place et les appareils doivent être munis d'événements individuels séparés.

It is for this reason that, in addition to following proper vent sizing, construction and safety requirements from the National Fuel Gas Code, ANSI Z223.1 or in Canada, from the Natural Gas and Propane Installation Code (CSA B149.1) as well as all applicable local codes, it is required that installers provide some means to prevent operation with a blocked common vent. It is suggested that a blocked vent safety system be employed such that if the switch from one appliance trips due to excessive stack spill or back pressure indicating a blocked vent condition, that all appliances attached to the vent be locked out and prevented from operating. Note that the Pennant is equipped with a blocked vent safety (pressure) switch, as shipped. However, this safety switch has only been designed and tested to be effective in installations where the Pennant is vented separately and NOT common vented with other appliances. As an additional precaution, it is recommended that a Carbon Monoxide (CO) alarm be installed in all enclosed spaces containing combustion appliances. If assistance is required in determining how a blocked vent safety system should be connected to a LAARS product, please call Applications Engineering at the Rochester phone number on the back cover of this manual.

Refer to the installation and operating instructions on all appliances to be common vented for instructions, warnings, restrictions and safety requirements. If safe operation of all appliances connected to a common vent cannot be assured, including prevention of spillage of flue gases into living spaces, common venting should not be applied, and appliances should each be vented separately.

**2.2.4 Category III Vent**

When the Pennant is vented with horizontal discharge, it must be installed per this installation manual and the venting system manufacturer's installation instructions. The vent system must be sealed stainless steel, per **Table 5**.

Route the vent pipe to the heater as directly as possible. Seal all joints and provide adequate hangers as required in the venting system manufacturer's installation instructions. Horizontal portions of the

venting system must be supported to prevent sagging and may not have any low sections that could trap condensate.

The unit must not support the weight of the vent pipe. Horizontal runs must slope downwards not less than 1/4 inch per foot (2 cm/m) from the unit to the vent terminal.

*L'appareil ne doit pas supporter le poids de la gaine d'évent. Les parties horizontales doivent être installées avec une pente de 2 cm/m (1/4 inch par pied) descendant de l'appareil vers la sortie de l'évent.*

Reference **Table 2** for the size of the Category III vent system. Up to three elbows can be used with 50 linear feet (15.2m) of pipe. Subtract 10 allowable linear feet (3.0m) for every additional elbow used.

**2.3 Locating Vent & Combustion Air Terminals**

**2.3.1 Side Wall Vent Terminal**

The appropriate Laars side wall vent terminal must be used, and is listed in the installation and operation manual. The terminal provides a means of installing the vent piping through the building wall, and must be located in accordance with ANSI Z223.1/NFPA 54 and applicable local codes. In Canada, the installation must be in accordance with CSA B149.1 and local applicable codes. Consider the following when installing the terminal:

1. **Figure 3** shows the requirements for mechanical vent terminal clearances for the U.S. and Canada.
2. Locate the vent terminal so that vent gases cannot be drawn into air conditioning system inlets.
3. Locate the vent terminal so that vent gases cannot enter the building through doors, windows, gravity inlets or other openings. Whenever possible, locations under windows or near doors should be avoided.
4. Locate the vent terminal so that it cannot be blocked by snow. The installer may determine that a vent terminal must be higher than the minimum shown in codes, depending upon local conditions.
5. Locate the terminal so the vent exhaust does not settle on building surfaces or other nearby objects. Vent products may damage such surfaces or objects.
6. If the boiler or water heater uses ducted combustion air from an intake terminal located on the same wall, locate the vent terminal at least

Term	Description
Pipe	Must comply with UL Standard 1738 such as Type AL29-4C Stainless Steel (either insulated or non-insulated).
Joint Sealing	Follow vent manufacturer's instructions.

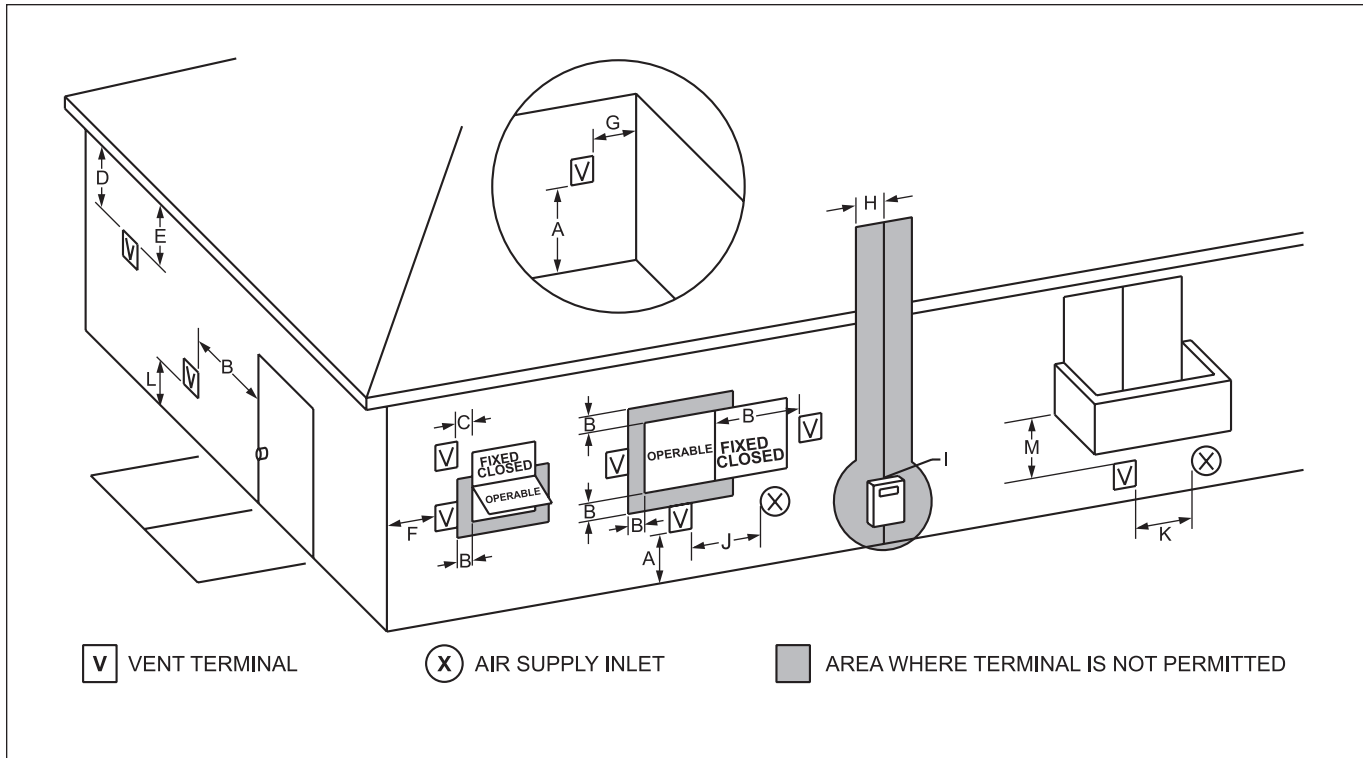

**Table 5. Required Horizontal Venting Material.**



	U.S. Installations (see note 1)	Canadian Installations (see note 2)
<b>A=</b> Clearance above grade, veranda, porch, deck, or balcony	12 inches (30 cm)	12 inches (30 cm)
<b>B=</b> Clearance to window or door that may be opened	Direct Vent Only: 12 inches (30 cm) Other Than Direct Vent: 4 feet (1.2 m) below or to side of opening; 1 foot (30 cm) above opening	36 inches (91 cm)
<b>C=</b> Clearance to permanently closed window	See note 4	See note 5
<b>D=</b> Vertical clearance to ventilated soffit located above the terminal within a horizontal distance of 2 feet (61cm) from the center line of the terminal	See note 4	See note 5
<b>E=</b> Clearance to unventilated soffit	See note 4	See note 5
<b>F=</b> Clearance to outside corner	See note 4	See note 5
<b>G=</b> Clearance to inside corner	See note 4	See note 5
<b>H=</b> Clearance to each side of center line extended above meter/regulator assembly	See note 4	3 feet (91 cm) within a height 15 feet above the meter/regulator assembly
<b>I=</b> Clearance to service regulator vent outlet	See note 4	3 feet (91 cm)
<b>J=</b> Clearance to non mechanical air supply inlet to building or the combustion air inlet to any other appliance	Direct Vent Only: 12 inches (30 cm) Other Than Direct Vent: 4 feet (1.2 m) below or to side of opening; 1 foot (30 cm) above opening	36 inches (91 cm)
<b>K=</b> Clearance to a mechanical air supply inlet	3 feet (91 cm) above if within 10 feet (3 m) horizontally	6 feet (1.83 m)
<b>L=</b> Clearance above paved sidewalk or paved driveway located on public property	Vent termination not allowed in this location	Vent termination not allowed in this location
<b>M=</b> Clearance under veranda, porch, deck, or balcony	See note 4	12 inches (30 cm) (see note 3)
<b>Notes:</b>		
1. In accordance with the current ANSI Z223.1 / NFPA 54 National Fuel Gas Code.		
2. In accordance with the current CSA B149.1, Natural Gas and Propane Installation Code.		
3. Permitted only if veranda, porch, deck, or balcony is fully open on a minimum of two sides beneath the floor.		
4. For clearances not specified in ANSI Z223.1 / NFPA 54, clearance is in accordance with local installation codes and the requirements of the gas supplier.		
5. For clearances not specified in CSA B149.1, clearance is in accordance with local installation codes and the requirements of the gas supplier.		

Figure 3. Vent Terminal Clearances.

3 feet (0.9m) horizontally from the combustion air terminal, and locate the vent terminal at least 1 foot (0.3m) above the combustion air terminal.

 <b>WARNING</b>
<p>The outdoor vent terminal gets hot. Unit must be installed in such a way as to reduce the risk of burns from contact with the vent terminal.</p>
 <b>AVERTISSEMENT</b>
<p>La sortie d'évent à l'extérieur devient très chaude. Elle doit être installée de façon à réduire le risque de brûlures au contact de l'extrémité de l'évent.</p>

**Important Note: Massachusetts Code Requirement.**

**From Massachusetts Rules and Regulations 248 CMR 5.08:**

**(a) For all side wall horizontally vented gas fueled equipment installed in every dwelling, building or structure used in whole or in part for residential purposes, including those owned or operated by the Commonwealth and where the side wall exhaust vent termination is less than seven (7) feet above finished grade in the area of the venting, including but not limited to decks and porches, the following requirements shall be satisfied:**

1. **INSTALLATION OF CARBON MONOXIDE DETECTORS.**  
 At the time of installation of the side wall horizontal vented gas fueled equipment, the installing plumber or gasfitter shall observe that a hard-wired carbon monoxide detector with an alarm and battery back-up is installed on the floor level where the gas equipment is to be installed. In addition, the installing plumber or gasfitter shall observe that a battery operated or hard-wired carbon monoxide detector with an alarm is installed on each additional level of the dwelling, building or structure served by the side wall horizontal vented gas fueled equipment. It shall be the responsibility of the property owner to secure the services of qualified licensed professionals for the installation of hard-wired carbon monoxide detectors.
  - a. In the event that the side wall horizontally vented gas fueled equipment is installed in a crawl space or an attic, the hard-wired carbon monoxide detector with alarm and battery back-up may be installed on the next adjacent floor level.
  - b. In the event that the requirements of this subdivision cannot be met at the time of completion of installation, the owner shall have a period of thirty (30) days to comply with the above requirements; provided,

however, that during said thirty (30) day period, a battery operated carbon monoxide detector with an alarm shall be installed.

2. **APPROVED CARBON MONOXIDE DETECTORS.**  
 Each carbon monoxide detector as required in accordance with the above provisions shall comply with NFPA 720 and be ANSI/UL 2034 listed and IAS certified.
  3. **SIGNAGE.**  
 A metal or plastic identification plate shall be permanently mounted to the exterior of the building at a minimum height of eight (8) feet above grade directly in line with the exhaust vent terminal for the horizontally vented gas fueled heating appliance or equipment. The sign shall read, in print size no less than one-half (1/2) inch in size, "GAS VENT DIRECTLY BELOW. KEEP CLEAR OF ALL OBSTRUCTIONS".
  4. **INSPECTION.**  
 The state or local gas inspector of the side wall horizontally vented gas fueled equipment shall not approve the installation unless, upon inspection, the inspector observes carbon monoxide detectors and signage installed in accordance with the provisions of 248 CMR 5.08(2)(a) 1 through 4.
- (b) EXEMPTIONS: The following equipment is exempt from 248 CMR 5.08(2)(a) 1 through 4:**
1. The equipment listed in Chapter 10 entitled "Equipment Not Required To Be Vented" in the most current edition of NFPA 54 as adopted by the Board; and
  2. Product Approved side wall horizontal vented gas fueled equipment installed in a room or structure separate from the dwelling, building or structure used in whole or in part for residential purposes.
- (c) MANUFACTURER REQUIREMENTS – GAS EQUIPMENT VENTING SYSTEM PROVIDED. When the manufacturer of Product Approved side wall horizontally vented gas equipment provides a venting system design or venting system components with the equipment, the instructions provided by the manufacturer for installation of the equipment and the venting system shall include:**
1. Detailed instructions for the installation of the venting system design or the venting system components; and
  2. A complete parts list for the venting system

design or venting system.

**(d) MANUFACTURER REQUIREMENTS – GAS EQUIPMENT VENTING SYSTEM NOT PROVIDED. When the manufacturer of a Product Approved side wall horizontally vented gas fueled equipment does not provide the parts for venting the fuel gases, but identifies “special venting systems”, the following requirements shall be satisfied by the manufacturer:**

1. The referenced “special venting system” instructions shall be included with the appliance or equipment installation instructions; and
2. The “special venting systems” shall be Product Approved by the Board, and the instructions for that system shall include a parts list and detailed installation instructions.

**(e) A copy of all installation instructions for all Product Approved side wall horizontally vented gas fueled equipment, all venting instructions, all parts lists for venting instructions, and/or all venting design instructions shall remain with the appliance or equipment at the completion of the installation.**

**2.3.2 Side Wall Combustion Air Terminal**

The Laars side wall combustion air terminal (listed in [Table 2](#)) must be used when the unit takes its combustion air through a duct from a side wall. Consider the following when installing the terminal:

1. Do not locate the air inlet terminal near a source of corrosive chemical fumes (e.g., cleaning fluid, chlorinated compounds, etc.)
2. Locate the terminal so that it will not be subject to damage by accident or vandalism.
3. Locate the combustion air terminal so that it cannot be blocked by snow. The National Fuel Gas Code requires that it be at least 12 inches (30 cm) above grade, but the installer may determine it should be higher, depending upon local conditions.
4. If the Pennant is side-wall vented to the same wall, locate the vent terminal at least 3 feet (0.9m) horizontally from the combustion air terminal, and locate the vent terminal at least 1 foot (0.3m) above the combustion air terminal (see [Figure 3](#)).

**2.3.3 Vertical Vent Terminal**

When the unit is vented through the roof, the vent must extend at least 3 feet (0.9m) above the point at which it penetrates the roof. It must extend at least 2 feet (0.6m) higher than any portion of a building within a horizontal distance of 10 feet (3.0m), and high enough above the roof line to prevent blockage from

snow. When the combustion air is taken from the roof, the combustion air must terminate at least 12" (30cm) below the vent terminal (see [Figure 2](#)).

**2.3.4 Vertical Combustion Air Terminal**

When combustion air is taken from the roof, a field-supplied rain cap or an elbow arrangement must be used to prevent entry of rain water (see [Figure 2](#)). The opening on the end of the terminal must be at least 12" (30cm) above the point at which it penetrates the roof, and high enough above the roof line to prevent blockage from snow. When the vent terminates on the roof, the combustion air must terminate at least 12" (30cm) below the vent terminal.

**2.4 Common Vent Test — Boilers**

When an existing boiler is removed from a common venting system, the common venting system is likely to be too large for proper venting of the appliances remaining connected to it.

At the time of removal of an existing boiler, the following steps shall be followed with each appliance remaining connected to the common venting system placed in operation, while the other appliances remaining connected to the common venting system are not in operation.

1. Seal any unused openings in the common venting system.
2. Visually inspect the venting system for proper size and horizontal pitch and determine there is non blockage or restriction, leakage, corrosion and other deficiencies which could cause an unsafe condition.
3. Insofar as it is practical, close all building doors and windows and all doors between the space in which the appliances remaining connected to the common venting system are located and other spaces of the building. Turn on clothes dryers and any appliance not connected to the common venting system. Turn on any exhaust fans, such as range hoods and bathroom exhausts, so they will operate at maximum speed. Do not operate a summer exhaust fan. Close fireplace dampers.
4. Place in operation the appliance being inspected. Follow the lighting instructions. Adjust thermostat so appliance will operate continuously.
5. Test for spillage at the draft hood relief opening after 5 minutes of main burner operation. Use the flame of a match or candle, or smoke from a cigarette, cigar or pipe.
6. After it has been determined that each appliance remaining connected to the common venting system properly vents when tested as outlined above, return doors, windows, exhaust fans, fireplace dampers and any other gas burning appliance to their previous conditions of use.
7. Any improper operation of the common venting system should be corrected so that the installation

conforms with the National Fuel Gas Code, ANSI Z223.1/NFPA 54 and/or CSA B149.1, Natural Gas and Propane Installation Codes. When resizing any portion of the common venting system, the common venting system should be resized to approach the minimum size as determined using the appropriate tables in Appendix F in the National Fuel Gas Code, ANSI Z223.1/NFPA 54 and/or CSA B149.1, Natural Gas and Propane Installation Codes.

**2.4 Vérification des événements communs — Chaudières**

*Lorsqu’une chaudière existante est déconnectée du réseau d’événets commun, ce réseau d’événets commun devient probablement trop grand pour les appareils qui lui restent connectés. Lorsqu’une chaudière existante est retirée, les étapes suivantes doivent être accomplies pour chaque appareil qui reste connecté au réseau d’événets commun utilisé, alors que les autres appareils qui sont encore connectés au réseau commun d’événets ne sont pas en fonctionnement.:*

1. *Sceller toutes les ouvertures non utilisées du système d’évacuation.*
2. *Inspecter de façon visuelle le système d’évacuation pour déterminer la grosseur et l’inclinaison horizontale qui conviennent et s’assurer que le système est exempt d’obstruction, d’étranglement, de fuite, de corrosion et autres défaillances qui pourraient présenter des risques.*
3. *Dans la mesure du possible, fermer toutes les portes et les fenêtres du bâtiment et toutes les portes entre l’espace où les appareils toujours raccordés au système d’évacuation sont installés et les autres espaces du bâtiment. Mettre en marche les sècheuses, tous les appareils non raccordés au système d’évacuation commun et tous les ventilateurs d’extraction comme les hottes de cuisinière et les ventilateurs des salles de bain. S’assurer que ces ventilateurs fonctionnent à la vitesse maximale. Ne pas faire fonctionner les ventilateurs d’été. Fermer les registres des cheminées.*
4. *Mettre l’appareil inspecté en marche. Suivre les instructions d’allumage. Régler le thermostat de façon continue.*
5. *Faire fonctionner le brûleur principal pendant 5 min ensuite, déterminer si le coupe-tirage déborde à l’ouverture de décharge. Utiliser la flamme d’une allumette ou d’une chandelle ou la fumée d’une cigarette, d’un cigare ou d’une pipe.*
6. *Une fois qu’il a été déterminé, selon la méthode indiquée ci-dessus, que chaque appareil raccordé au système d’évacuation est mis à l’air libre de façon adéquate. Remettre les portes et les fenêtres, les ventilateurs, les registres de cheminées et les appareils au gaz à leur position originale.*

7. *Tout mauvais fonctionnement du système d’évacuation commun devrait être corrigé de façon que l’installation soit conforme au National Fuel Gas Code, ANSI Z223.1/NFPA 54 et (ou) aux codes d’installation CSA-B149.1. Si la grosseur d’une section du système devrait être modifié, le système devrait être modifié pour respecter les valeurs minimales des tableaux pertinents de l’appendice F du National Fuel Gas Code, ANSI Z223.1/NFPA 54 et (ou) les codes d’installation CSA-B149.1*

**2.5 Vent Terminals for Outdoor Units**

For outdoor applications, the vent and combustion air openings must be covered with proper terminals to prevent rain, snow and other objects from falling into the Pennant.

If local codes allow, outdoor installations may use 1' (one foot) of appropriately sized galvanized single wall or type "B" vent and a rain cap for exhaust vent termination in the default configuration (venting out of the top). An appropriately sized 90° elbow, positioned with the opening facing down, may be used on the combustion air inlet in the default configuration on the back of the unit. Note that some local codes may require a higher vertical vent height, extending above any perimeter fencing, etc. In installations where the appearance of the vent is objectionable, the low profile vent terminals listed in **Table 6** may be used.

Part numbers for the low profile terminals to cover the vent and combustions air openings are shown in **Table 6**.

Size	Outdoor Vent Terminal	Outdoor Combustion Air Terminal
500	20254703	D2007900
750	20254705	D2007900
1000	20254705	D2008000
1250	D2007700	D2008000
1500	D2007700	D2008000
1750	D2007800	D2008000
2000	D2007800	D2008200

**Table 6. Vent Terminals for Outdoor Units.**

## SECTION 3. Gas Supply and Piping

### 3.1 Gas Supply and Piping

Gas piping should be supported by suitable hangers or floor stands, not by the appliance.

The Pennant's gas train allows the user to pipe the gas from either the right side or the left side of the unit. As shipped, the right side of the gas train is capped off, and there is a manual valve on the left side. If desired, the manual valve on the left side of the gas train may be moved to the right side, and the cap on the right side may be moved to the left.

Review the following instructions before proceeding with the installation.

1. Verify that the appliance is fitted for the proper type of gas by checking the rating plate. Pennant appliances are equipped to operate at elevations up to 10,000 feet (3050m). Pennant appliances may be adjusted to operate properly at altitudes above 2500 feet (see Section 6.5.2) and the input will be reduced if the heating value of the gas supply is below sea level values.
2. The maximum inlet gas pressure must not exceed 13" w.c. (3.2kPa). The minimum inlet gas pressure is 5 in. w.c. (1.2 kPa).
3. Refer to Table 7, size supply.
4. Run gas supply line in accordance with all applicable codes.
5. Locate and install manual shutoff valves in accordance with state and local requirements.
6. A sediment trap must be provided upstream of the gas controls.

7. All threaded joints should be coated with piping compound resistant to action of liquefied petroleum gas.
8. The appliance and its individual shutoff valve must be disconnected from the gas supply piping during any pressure testing of that system at test pressures in excess of 0.5 psig (3.45 kPa).
9. The unit must be isolated from the gas supply system by closing its individual manual shutoff valve during any pressure testing of the gas supply piping system at test pressures equal to or less than 0.5 psig (3.45 kPa).
10. The appliance and its gas connection must be leak tested before placing it in operation.
11. Purge all air from gas lines.

#### WARNING

Do not use open flame to check for leaks. An open flame could lead to explosion, which could result in property damage, serious injury or death.

#### AVERTISSEMENT

Ne recherchez pas les fuites avec une flamme nue. Une flamme nue peut provoquer une explosion qui peut causer des dommages matériels, de sévères blessures corporelles ou la mort.

**NOTE:** The Pennant appliance and all other gas appliances sharing the gas supply line must be firing at maximum capacity to properly measure the inlet supply pressure. The pressure can be measured at the supply pressure port on the gas valve. Low gas pressure could be an indication of an undersized gas meter, undersized gas supply lines and/or an obstructed gas supply line.

Size and Gas Type	Distance from Gas Meter or Last Stage Regulator					
	0-100'	0-31 m	100-200'	31-61m	200-300'	61-91m
500 natural	1½"	3.8 cm	2"	5.1 cm	2"	5.1 cm
500 propane	1"	2.5 cm	1½"	3.8 cm	1½"	3.8 cm
750 natural	2"	5.1 cm	2"	5.1 cm	2½"	6.4 cm
750 propane	1½"	3.8 cm	1½"	3.8 cm	2"	5.1 cm
1000 natural	2"	5.1 cm	2½"	6.4 cm	3"	7.6 cm
1000 propane	1½"	3.8 cm	2"	5.1 cm	2½"	6.4 cm
1250 natural	2½"	6.4 cm	2½"	6.4 cm	3"	7.6 cm
1250 propane	2"	5.1 cm	2"	5.1 cm	2½"	6.4 cm
1500 natural	2½"	6.4 cm	3"	7.6 cm	3"	7.6 cm
1500 propane	2"	5.1 cm	2½"	6.4 cm	2½"	6.4 cm
1750 natural	2½"	6.4 cm	3"	7.6 cm	3"	7.6 cm
1750 propane	2"	5.1 cm	2½"	6.4 cm	2½"	6.4 cm
2000 natural	3"	7.6 cm	3"	7.6 cm	3½"	8.9 cm
2000 propane	2½"	6.4 cm	2½"	6.4 cm	3"	7.6 cm

#### Notes:

1. These figures are based on 1/2" (0.12 kPa) water column pressure drop.
2. Check supply pressure and local code requirements before proceeding with work.
3. Pipe fittings must be considered when determining gas pipe sizing.

Table 7. Gas Piping Size.

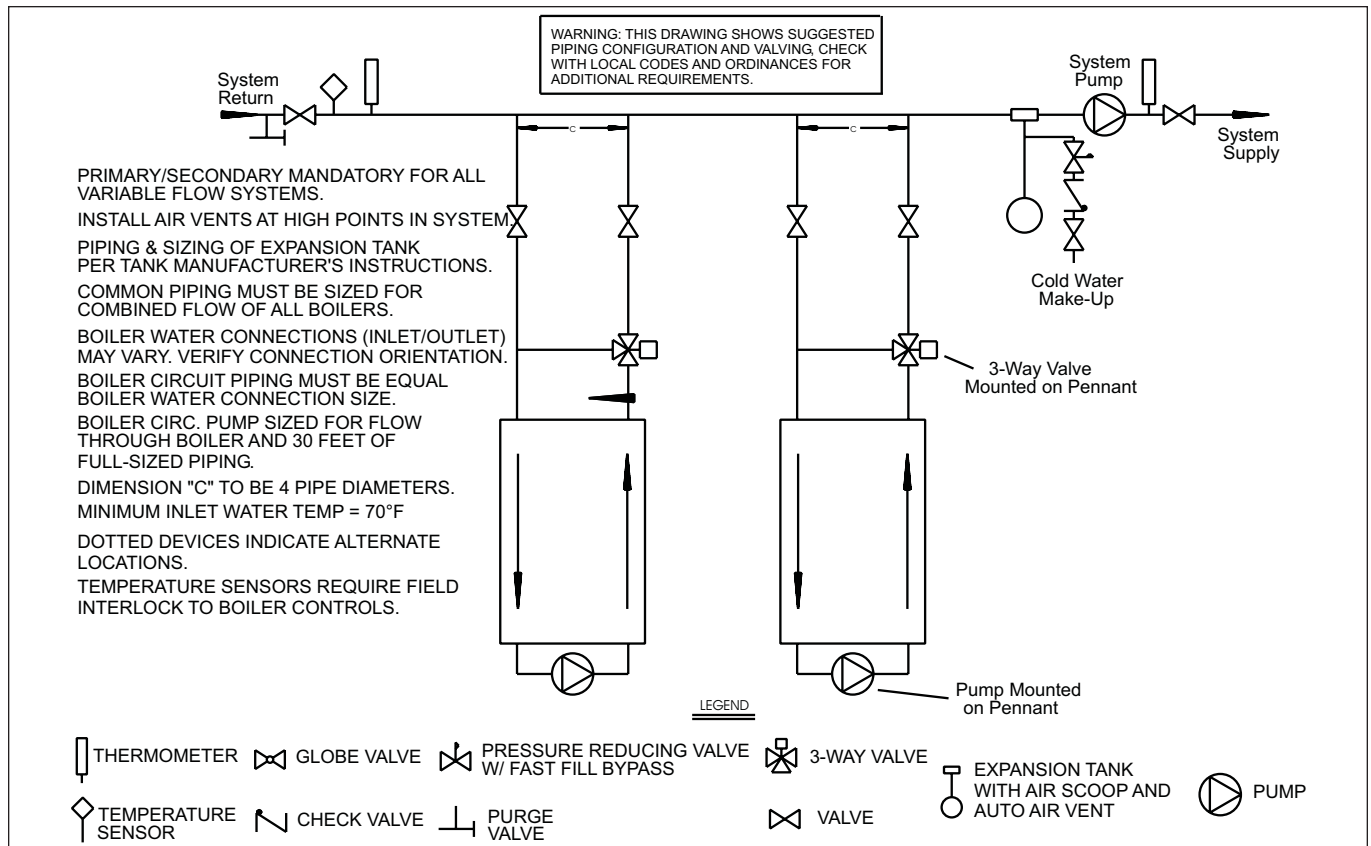

Figure 4. Suggested Piping - Hydronic Boiler.

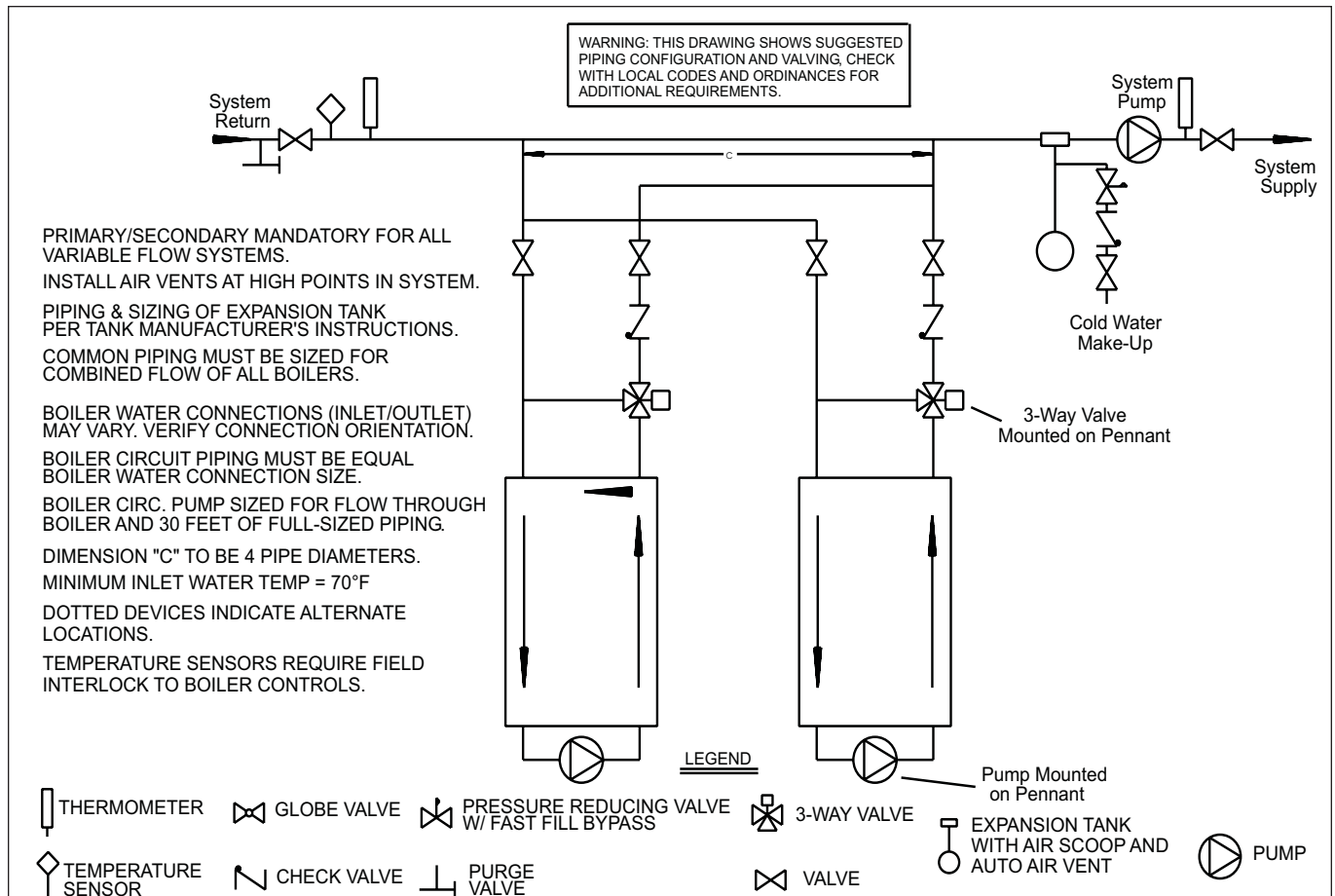

Figure 5. Hydronic Piping — One Boiler, Multi-Temperature System.

## SECTION 4A. Water Connections — Pennant Boiler

### 4A.1 Heating System Piping: Hot Supply Connections — Boiler

**NOTE:** This appliance must be installed in a closed pressure system with a minimum of 12 psig (82.7 kPa) static pressure at the boiler.

Hot water piping should be supported by suitable hangers or floor stands. Do not support piping with this appliance. Due to expansion and contraction of copper pipe, consideration should be given to the type of hangers used. Rigid hangers may transmit noise through the system resulting from the piping sliding in the hangers. It is recommended that padding be used when rigid hangers are installed. Maintain 1" clearance to combustibles for hot water pipes.

Pipe the discharge of the relief valve (full size) to a drain or in a manner to prevent injury in the event of pressure relief. Install an air purger, an air vent, a diaphragm-type expansion tank, and a hydronic flow check in the system supply loop. Minimum fill pressure must be 12 psig (82.7 kPa). Install shutoff valves where required by code.

See suggested piping diagrams (Figures 4-5). These diagrams are meant only as a guide. Components required by local codes must be properly installed.

Note the recommended location of the temperature sensor on the diagrams; you must provide a location for the additional sensor shipped with the Pennant. This sensor may be strapped onto pipe from 1" to 4" diameter, or inserted into an immersion well.

### 4A.2 Cold Water Make-Up — Boiler

1. Connect the cold water supply to the inlet connection of an automatic fill valve.
2. Install a suitable back flow preventer between the automatic fill valve and the cold water supply.
3. Install shut off valves where required.

**NOTE:** The boiler, when used in connection with a refrigeration system, must be installed so the chilled medium is piped in parallel with the boiler with appropriate valves to prevent the chilled medium from entering the boiler.

The boiler piping system of a hot water heating boiler connected to heating coils located in air handling appliances where they may be exposed to refrigerated air circulation must be equipped with flow control valves or other automatic means to prevent gravity circulation of the boiler water during the cooling cycle.

A boiler installed above radiation level, or as required by the authority having jurisdiction, must be provided with a low water cutoff device either as a part of the boiler or at the time of boiler installation.

### 4A.3 Water Flow Requirements — Boiler

Low Temperature Pennant Boilers are equipped with a mounted pump. The pumps are sized for the boiler's head loss and 30 feet of full-size piping (same

size as boiler outlet), with a normal number of fittings. The boilers must be piped in a primary-secondary system, such that the boiler's pump only serves the boiler. Figures 4 and 5 show examples of this type of piping.

The minimum inlet water temperature to the Pennant is 70°F (20°C). The mixing system on the Pennant will ensure that the heat exchanger in the Pennant does not see water that is less than 120°F (49°C), so that excessive condensation does not form on the heat exchanger.

Table 8 shows a relationship between water flow through the boiler and the temperature difference (rise) between the inlet and outlet of the boiler. This table will enable the user to test the boiler for proper water flow. Since the boiler has a mixing system that sends a portion of the hot water from the boiler outlet to the boiler inlet, the water flow coming out of the mixing system will vary, depending on the return water temperature.

### 4A.4 Freeze Protection — Boiler

Boiler installations are not recommended in areas where the danger of freezing exists unless proper precautions are made for freeze protection. A non toxic, heating system, anti-freeze may be added to the hydronic system provided that the concentration does not exceed 50% and the anti freeze contains an anti foamant. Power outage, interruption of gas supply, failure of system components, activation of safety devices, etc., may prevent a boiler from firing. **Any time a boiler is subjected to freezing conditions, and the boiler is not able to fire, and/or the water is not able to circulate, there is a risk of freezing in the boiler or in the pipes in the system.** When water freezes, it expands. This can result in bursting of pipes in the system, or damage to the boiler, which could result in leaking or flooding conditions.

**IMPORTANT NOTES:** Different glycol products may provide varying degrees of protection. Glycol products must be maintained properly in a heating system, or they may become ineffective. Consult the glycol specifications, or the glycol manufacturer, for information about specific products, maintenance of solutions, and set up according to your particular conditions. Never use ethylene glycol (automotive antifreeze).

Size	20°F (11°C)		25°F (14°C)		30°F (17°C)		35°F (19°C)	
	gpm	lpm	gpm	lpm	gpm	lpm	gpm	lpm
500	43	161	34	129	26	107	24	92
750	64	241	51	193	43	161	36	138
1000	85	321	68	257	57	214	49	184
1250	106	401	85	322	71	269	61	231
1500	128	483	102	386	85	322	73	276
1750	N/R	N/R	119	451	99	375	85	322
2000	N/R	N/R	103	515	113	429	97	368

**Notes:** gpm = gallons per minute, lpm = liters per minute, Maximum temperature rise is 35°F (19°C), as shown. N/R = not recommended.

**Table 8. Temperature Rise - Boiler.**

## SECTION 4B. Water Connections — Pennant Water Heater

### 4B.1 Water System Piping — Water Heater

Hot water piping should be supported by suitable hangers or floor stands. Do not support piping with this appliance. Due to expansion and contraction of copper pipe, consideration should be given to the type of hangers used. Rigid hangers may transmit noise through the system resulting from the piping sliding in the hangers. It is recommended that padding be used when rigid hangers are installed.

The Pennant can be used with several different types of readily available storage tanks. Pennant units have a circulating pump built into the water heater. The pumps used are sized for the head loss through the heater, plus 30 feet (9.1 m) of full-sized piping (same size as boiler outlet) and a normal number of fittings. Pumps used are sized for soft, normal or hard water, so make sure the unit matches the water quality of the installation.

Pipe the outlet from the heater's relief valve such that any discharge from the relief valve will be conducted to a suitable place for disposal when relief occurs. Do not reduce line size or install any valves in this line. The line must be installed to allow complete drainage of both the valve and the line.

Suggested piping diagrams are shown in **Figures 6,7,8 and 9**. These diagrams are meant only as a guide. Components required by local codes must be properly installed.

Note the recommended location of the temperature sensor on the diagrams. The Pennant is shipped with an additional sensor that can be used in the storage tank, in lieu of a separate tank thermostat.

The minimum inlet water temperature for the Low-Temp Pennant is 70°F (20°C). The mixing system on the Pennant will ensure that the heat exchanger in the Pennant does not see water that is less than 120°F (49°C), so that excessive condensation does not form on the heat exchanger.

### 4B.2 Hot Water Supply Piping — Water Heater

Follow the tank manufacturer's guidelines for completion of the hot water system connections.

**NOTE: A listed temperature and pressure relief valve listed as complying with the Standard for Relief Valves and Automatic Gas Shutoff Devices for Hot Water Supply Systems (ANSI Z21.22/ CSA 4.4), of suitable discharge capacity must be installed in the separate storage tank system.**

If the Pennant water heater is installed in a closed water supply system, such as one having a backflow

preventer in the cold water supply line, the relief valve may discharge periodically, due to thermal expansion. Means (such as a properly-sized expansion tank) shall be provided to control thermal expansion. Contact the water supplier or local plumbing inspector on how to control this situation.

### 4B.3 Water Flow Requirements — Water Heater

In a water heating application (an open system), new water is constantly being introduced. With the new water comes a fresh supply of minerals that can be deposited on the unit's heat exchanger. This is commonly known as scaling. The amount of minerals will depend upon the hardness of the water. Water can also be aggressive, and can erode metals, including copper, if the water is moved too quickly. The water flow requirements for the Pennant water heater are based upon the hardness of the water. The water flow is kept high enough to prevent scaling, but low enough to prevent tube erosion. For extremely soft or hard water, cupro-nickel tubes are available. Contact a Laars representative if you have questions or concerns about water quality.

Pennant water heaters are built with a mounted pump that is sized for soft, normal or hard water. The pumps used are sized for the head loss through the heater, plus 30 feet (9.1m) of full-sized piping (same size as heater outlet) and a normal number of fittings.

**Table 9** specifies water flow rates for water heaters, which will enable the user to ensure that the Pennant is getting the correct water flow when it is in operation.

### 4B.4 Combined Water Heating (potable) and Space Heating — Water Heater

**NOTE:** Combined systems must be allowed by and installed per local codes.

Piping and components connected to this water heater for the space heating application shall be suitable for use with potable water.

Toxic chemicals, such as used for boiler treatment, shall not be introduced into the potable water used for space heating.

This water heater when used to supply potable water shall not be connected to any heating system or component(s) previously used with a non-potable water heating appliance.

**When the system requires water for heating at temperatures higher than required for other uses, an anti-scald mixing or tempering valve shall be installed to temper the water for those uses in order to reduce scald hazard potential.**

### 4B.5 Freeze Protection — Water Heater

Although Pennant water heaters are design-

certified for outdoor installations, such installations are not recommended in areas subject to freezing temperatures, unless proper precautions are taken.

Power outage, interruption of gas supply, failure of system components, activation of safety devices, etc., may prevent a heater from firing. **Any time a heater is subjected to freezing conditions, and the**

**heater is not able to fire, and/or the water is not able to circulate, there is a risk of freezing in the heater or in the pipes in the system.** When water freezes, it expands. This can result in bursting of pipes in the system, or damage to the heater, which could result in leaking or flooding conditions.

Contact the local factory representative or Laars for additional information.

Size	GPM Water Flow			Temperature Rise °F			LPM Water Flow			Temperature Rise °C		
	Soft	Normal	Hard	Soft	Normal	Hard	Soft	Normal	Hard	Soft	Normal	Hard
500	45	68	90	19	13	9	170	257	341	10	7	5
750	45	68	90	28	19	14	170	257	341	16	10	8
1000	45	68	90	38	25	19	170	257	341	21	14	10
1250	68	68	90	31	31	24	257	257	341	17	17	13
1500	68	68	90	38	38	28	257	257	341	21	21	16
1750	68	68	90	44	44	33	257	257	341	24	24	18
2000	112	112	112	30	30	30	424	424	424	17	17	17

**Notes:**  
 Soft Water = 1 to 7.5 grains hardness  
 Normal Water = 7.6 to 17 grains hardness  
 Hard Water = more than 17 grains hardness  
 GPM = gallons per minute  
 LPM = liters per minute

**Table 9. Temperature Rise — Water Heater.**

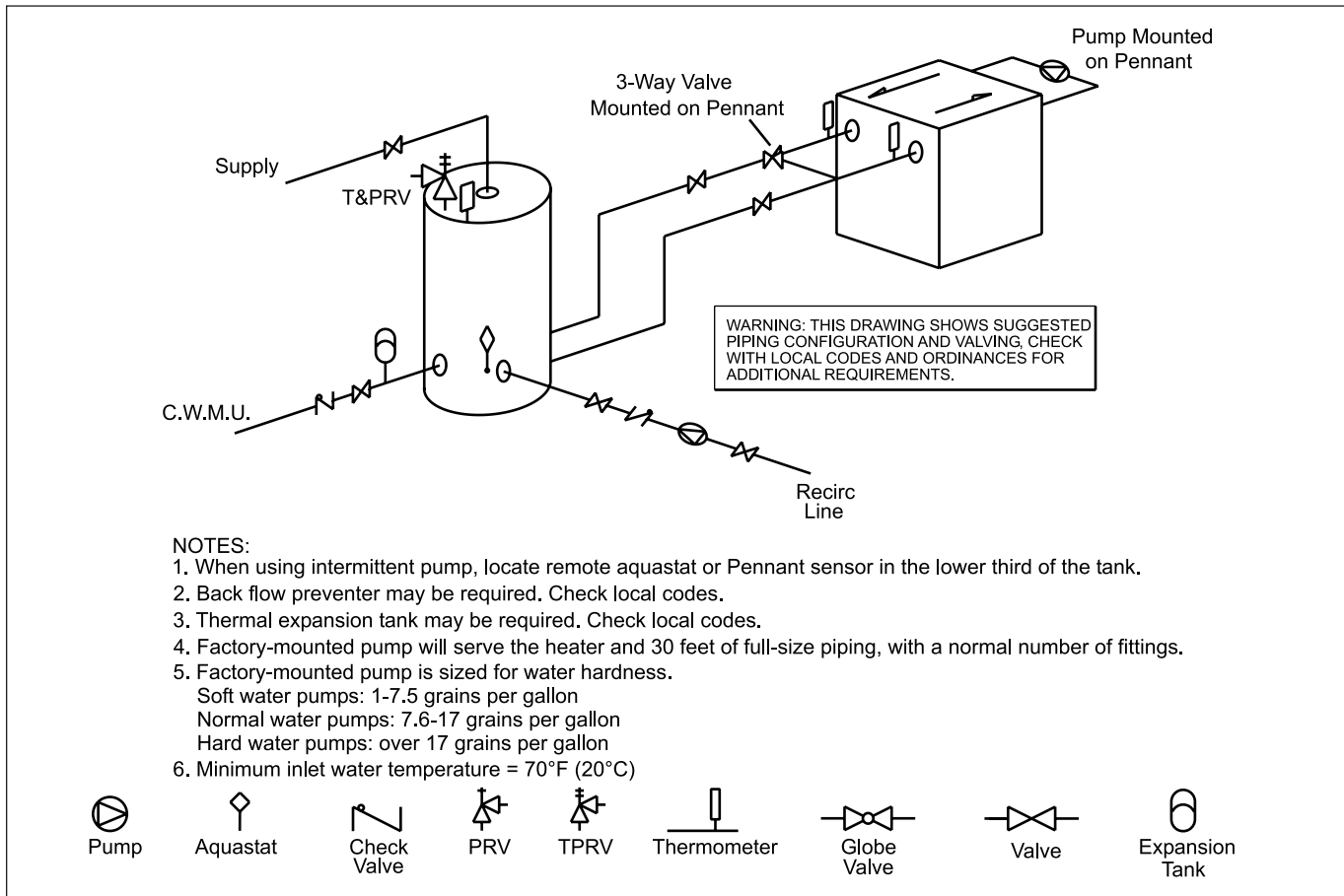

**Figure 6. Suggested Piping — One Water Heater, One Tank.**

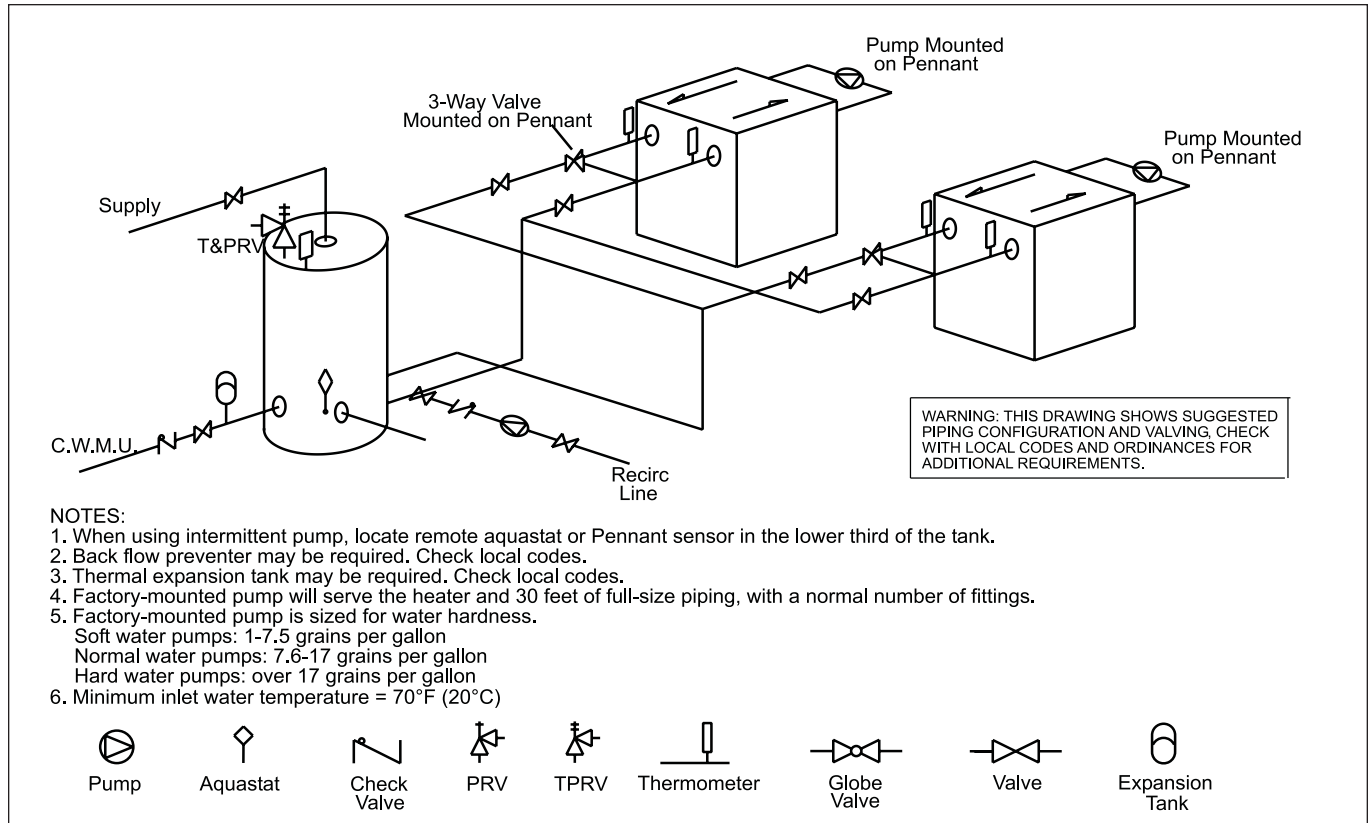

Figure 7. Suggested Piping — Multiple Water Heaters, One Tank.

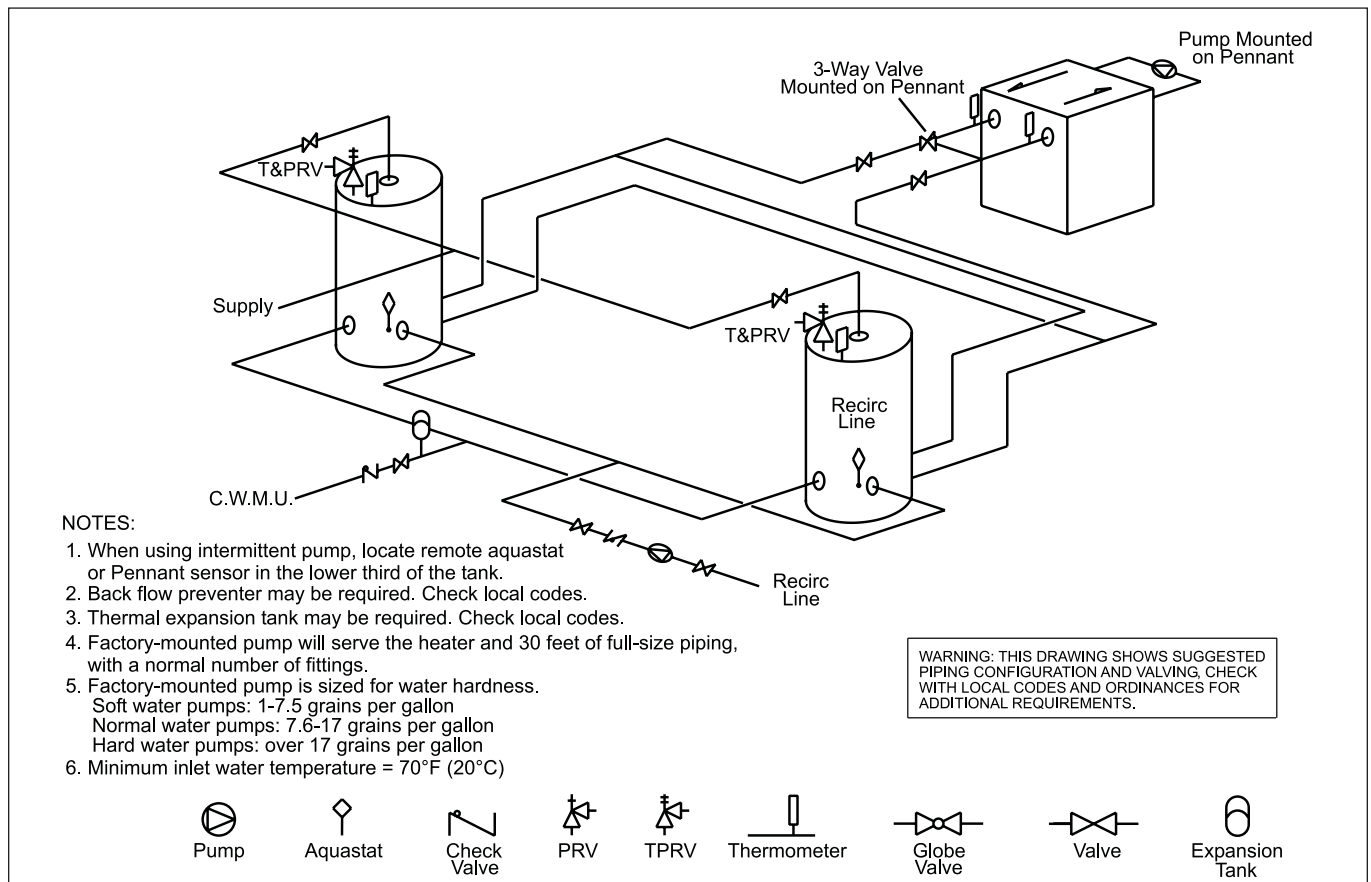

Figure 8. Suggested Piping — One Water Heater, Multiple Tanks.

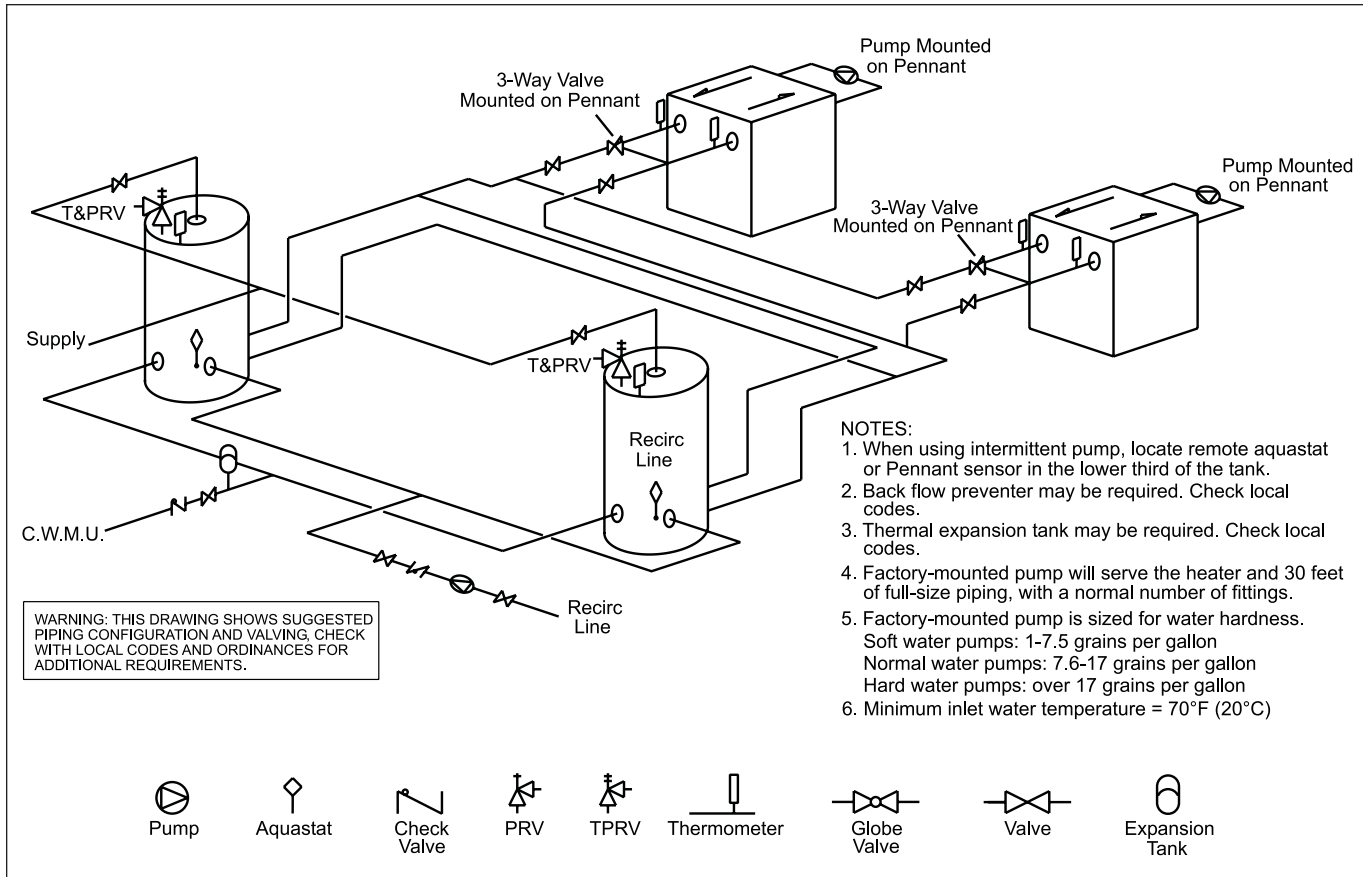

Figure 9. Suggested Piping — Multiple Water Heaters, Multiple Tanks.

## SECTION 5. Electrical Connections

### ⚠ WARNING

The appliance must be electrically grounded in accordance with the requirements of the authority having jurisdiction or, in the absence of such requirements, with the latest edition of the National Electrical Code, ANSI/NFPA 70, in the U.S. and with latest edition of CSA C22.1 Canadian Electrical Code, Part 1, in Canada. Do not rely on the gas or water piping to ground the metal parts of the boiler. Plastic pipe or dielectric unions may isolate the boiler electrically. Service and maintenance personnel, who work on or around the boiler, may be standing on wet floors and could be electrocuted by an ungrounded boiler.

### ⚠ AVERTISSEMENT

L'appareil doit être relié à la terre conformément aux exigences de la réglementation locale ou, en l'absence d'une telle réglementation, à la plus récente édition du National Electrical Code (Code national de l'électricité) ANSI/NFPA 70 aux États-Unis, et à la plus récente édition du Code Canadien de l'électricité 1<sup>ère</sup> partie (Canadian Electrical Code Part 1) CSA C22.1, au Canada. N'utilisez pas les tuyauteries d'eau ou de gaz pour mettre à la terre les pièces métalliques de la chaudière; des tuyauteries en plastique ou des raccords union diélectriques peuvent isoler électriquement la chaudière. Les employés qui sont appelés à travailler sur la chaudière ou autour peuvent être électrocutés par une chaudière qui n'est pas mise à la terre.

Single pole switches, including those of safety controls and protective devices must not be wired in a grounded line.

All electrical connections are made in the field wiring terminal strip, which is located to the left of the blower.

**NOTE:** All internal electrical components have been pre-wired. No attempt should be made to connect electrical wires to any other location except the wiring box.

## 5.1 Main Power

### 5.1.1 Sizes 500-1500

Pennant sizes 500-1500 use a single 120-volt fused supply. The installer can change the single service heaters to use a separate circuit for the pump, if desired. Instructions to make this change are found in [Section 5.1.3](#).

Pennant 500-1500 main power (L1, N1 & Ground) shall be connected to the three wires (10 AWG) supplied. Over-current protection ratings can be found in [Table 10](#).

### 5.1.2 Sizes 1750-2000

Pennant sizes 1750-2000 require two 120-volt fused supplies.

**Heater circuit** can be identified with 10AWG wires to include black, white and green (all solid colors). **Pump circuit** can be identified with three 12AWG wires to include a black wire with a white tracer (stripe), a white and green wire.

### 5.1.3 Separate Pump Circuit

Conversion to separate pump circuit will necessitate removing the three jumpers within the internal wiring of the 120-volt portion of the heater (see [Figure 10](#)). Only do this with the power disconnected to the unit!

To rewire the pump circuit, bring in another 120-volt fused supply (L2, N2 & Ground). Connect incoming power (L2) to the main power switch using spade (fork) terminal. From the other side of the main power switch connect to the main terminal block using a ¼" female insulated quick connect. This will be the same position where the jumper had terminated (see [Figure 10](#)). Connect N2 and Ground to the main terminal block using ¼" female insulated quick connect (refer to [Figure 10](#)).

### 5.1.4 All Sizes

Ladder diagrams are shown in [Figures 12 and 13](#). Wiring diagrams are shown in [Figures 14 through 16](#). Field wiring is shown in [Figure 11](#).

## 5.2 Field Wiring

**Temperature Sensor:** The Low Temperature Pennant is controlled by a sensor that requires placement in the system loop or storage tank. A sensor well is shipped with the unit, as well. This sensor placement allows the Pennant to be called for heat, based on the system temperature. The sensor is wired to terminals

on the Pennant temperature control at the factory.

**External Alarm:** The field terminal strip has terminals for a dry contact that is closed when the ignition control locks out. These terminals are labeled "ALRM" and "ALRM".

**Additional Call For Heat:** Terminals labeled "COMD" and "HTD" can be used to call the Pennant for heat. These terminals are shipped with a jumper between them. Remove the jumper to use these terminals. The Pennant is controlled by the temperature sensor, and the temperature must be calling for heat for the Pennant to fire, regardless of any connections between "COMD" and "HTD", but the Pennant will not fire if this connection is broken.

**Other Field Interlocks:** Other safety switches that are intended to prevent the Pennant from firing (such as fan proving switches, powered louver end switches, etc.) The terminals are marked "OTHER INTS <COM> <NO>". These terminals are shipped with a jumper between them. Remove jumper to use these terminals. The Pennant will not fire if this connection is broken.

Size	Single Circuit	Two Circuit	
		Heater	Pump
500	20	15	15
750	20	15	15
1000	(TACO) 20 / (B&G) 30	20	15
1250	30	25	15
1500	30	25	15
1750	—	25	20
2000	—	25	20

Table 10. Electrical Data (Amps).

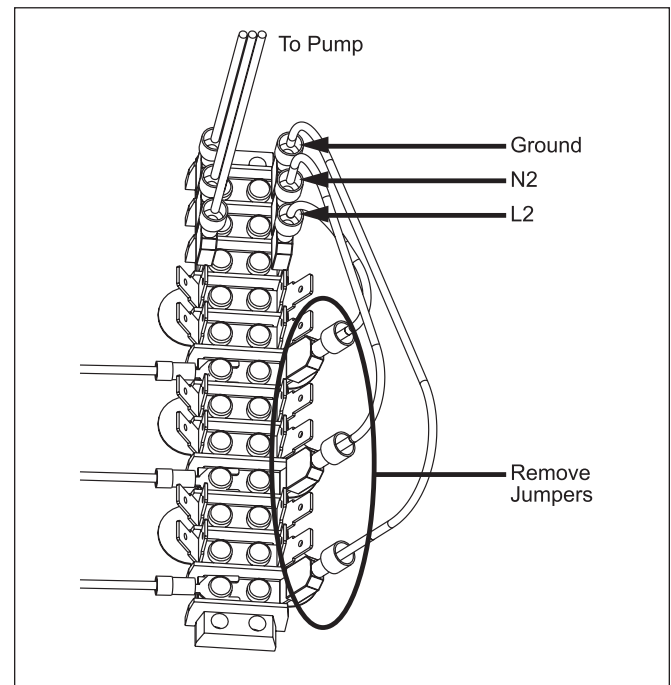

Figure 10. Removing Jumpers.

### 5.3 Low Water Cut-Off

When this boiler is installed above radiation level, it is required that a Low Water Cut-Off (LWCO) be installed unless this requirement is superceded by Jurisdictional requirements. Specific instructions for the installation are the following:

Locate the wiring diagram within this manual. On the wiring diagram, locate the connection points marked LWCO or Field Interlocks. These are the electrical connection points for the LWCO. Follow LWCO Manufacturer's Wiring Instructions.

Mechanically, install the LWCO device in a tee fitting in the supply piping above the highest point of the boiler (unless the boiler has an existing fitting for that purpose). Follow LWCO Manufacturer's Instructions for minimum pipe sizing.

Note: This boiler is a water tube boiler that requires water flow through the heat exchanger for proper operation. It does not have an operating water level and must be full at all times. In accordance with ANSI/ASME CSD-1 Section CW-210 and The National Fuel Gas Code ANSI Z223.1/NFPA 54 Section 10.3.5 a water tube boiler shall have a water flow proving device in lieu of a Low Water Cut Off.

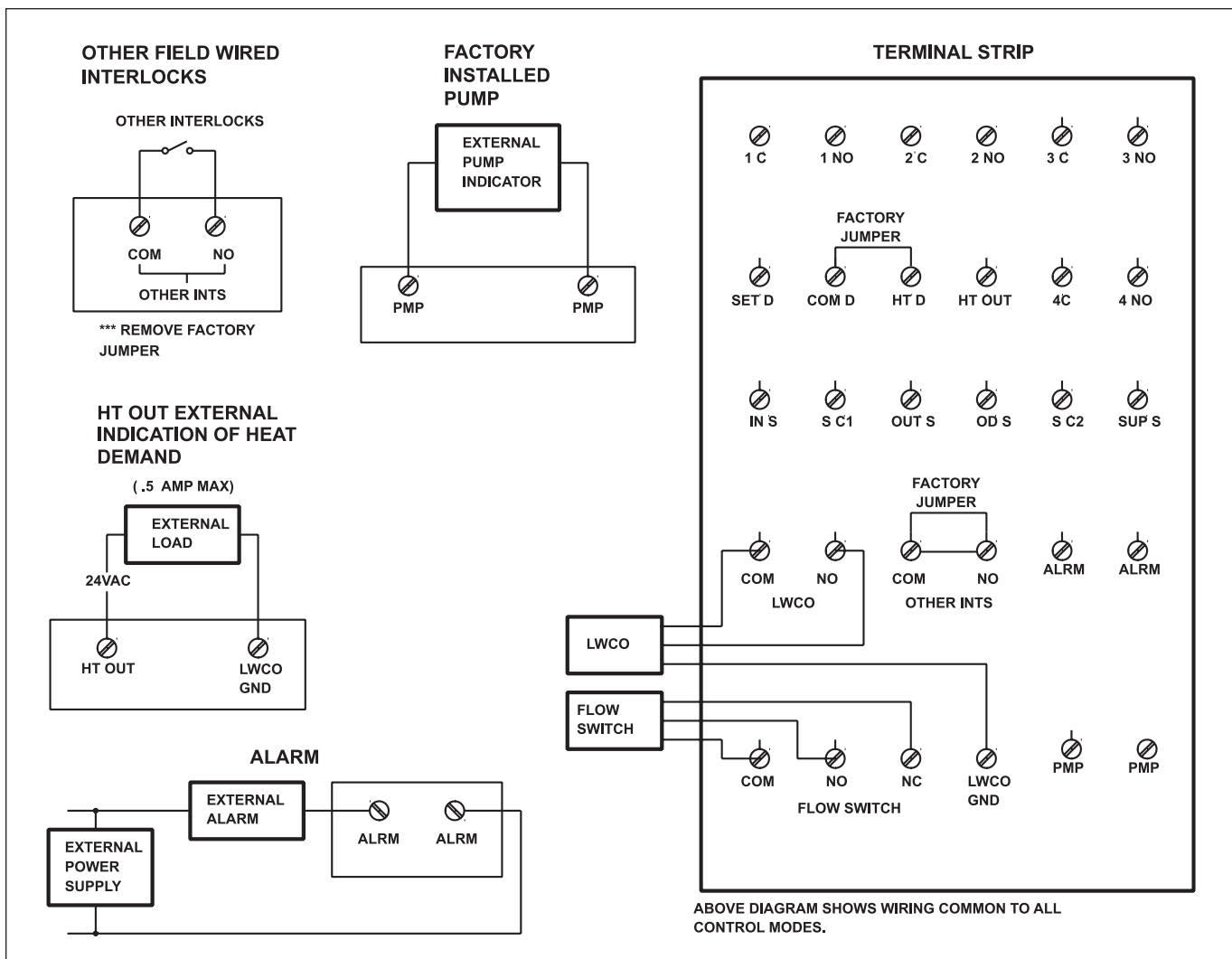

Figure 11. Field Wiring.











## SECTION 6. Operating Instructions

### 6.1 Filling the Boiler System

1. Ensure the system is fully connected. Close all bleeding devices and open make-up water valve. Allow system to fill slowly.
2. If make-up water pump is employed, adjust pressure switch on pumping system to provide a minimum of 12 psi (81.8 kPa) at the highest point in the heating loop.
3. If a water pressure regulator is provided on the make-up water line, adjust the pressure regulator to provide at least 12 psi (81.8 kPa) at the highest point in the heating loop.
4. Open bleeding devices on all radiation units at the high points in the piping throughout the system, unless automatic air bleeders are provided at such points.
5. Run system circulating pump for a minimum of 30 minutes with the boiler shut off.
6. Open all strainers in the circulating system, check flow switch operation, and check for debris. If debris is present, clean out to ensure proper circulation.
7. Recheck all air bleeders as described in Step 4.
8. Check liquid level in expansion tank. With the system full of water and under normal operating pressure, the level of water in the expansion tank should not exceed  $\frac{1}{4}$  of the total, with the balance filled with air.
9. Start up boiler according to the procedure in this manual. Operate the entire system, including the pump, boiler, and radiation units for one (1) hour.
10. Recheck the water level in the expansion tank. If the water level exceeds  $\frac{1}{4}$  of the volume of the expansion tank, open the tank drain, and drain to that level.
11. Shut down the entire system and vent all radiation units and high points in the system piping, as described in Step 4.
12. Close make-up water valve and check strainer in pressure reducing valve for sediment or debris from the make-up water line. Reopen make-up water valve.
13. Check gauge for correct water pressure and also check water level in the system. If the height indicated above the boiler insures that water is at the highest point in the circulating loop, then the system is ready for operation.
14. Refer to local codes and the make-up water valve manufacturer's instructions as to whether the make-up water valve should be left open or closed.
15. After placing the unit in operation, the ignition system safety shutoff device must be tested. First, shut off the manual gas valve, and call the unit for heat. After the pre-purge and ignitor heat-up time, the main gas terminals will be energized,

attempting to light, for four (4) seconds, and then will de-energize. The unit will go into lockout mode. Second, turn the power off and then on again, open the manual gas valve and allow the unit to light. While the unit is operating, close the manual gas valve and ensure that power to the main gas valve has been cut.

16. Within three (3) days of start-up, recheck all air bleeders and the expansion tank as described in Steps 4 and 8 above.

**Important:** The installer is responsible for identifying to the owner/operator the location of all emergency shutoff devices.

#### WARNING

Do not use this appliance if any part has been under water. Immediately call a qualified service technician to inspect the appliance and to replace any part of the control system and any gas control that may have been under water.

#### AVERTISSEMENT

N'utilisez pas cet appareil si l'une de ses pièces est passée sous l'eau. Appelez tout de suite un technicien en entretien et en réparation pour inspection de l'appareil et remplacement des pièces du système de commande, et des pièces de commande du circuit gaz, qui sont passées sous l'eau.

### 6.2 Sequence of Operation

The amber "Ready" light on the front panel indicates that the control system is energized. Upon a call for heat from the system temperature sensor, the green "Heat" indicator on the front panel will light. The green "Pump" indicator on the front panel will light.

Once the water flow switch makes, and if all of the safety interlocks are closed, the ignition module(s) will energize the blower(s) for a 15-second pre-purge, followed by a 20-second period to allow the ignitor(s) to heat.

Energizing the blower pressurizes the air box (which supplies air to the burners) and closes the normally-open contact(s) of the airflow pressure switch(es). This allows the ignition module to proceed with the ignition sequence.

The blocked flue pressure switch senses the pressure difference between the exhaust plenum and the blower inlet plenum. It will interrupt the airflow sensing circuit if this pressure exceeds a maximum value. If airflow is not proven, the ignition module will either attempt ignition again (up to three times) or will lockout (if the optional lockout ignition module is used).

The ignition module checks that the ignitor current has reached a minimum value and energizes the gas valves at the end of the ignitor-heating period.

The green indicators on the front panel will light, indicating that the gas valves are open. After a 4-second trial for ignition, the ignitor switches off, and

unless the flame sensor detects a flame, the gas valves will close and the ignition module will either attempt ignition again (up to three times) or will lockout (if the optional lockout ignition module is used).

**Note:** At this point, if gas pressure is below the required 5" w.c. minimum, the Pennant may lock out.

If flame is sensed, the burner will continue to fire as long as there is a call for heat. If there is a subsequent loss of flame signal, the burner will attempt re-ignition up to three times (only once if optional lockout ignition module is used.) Loss of flame signal from the first ignition module will cause shutdown of the heater.

When the call for heat is satisfied, the gas valves close and the blower(s) continues to run for 30 seconds. The pump will continue to run for the length of time selected at startup by the adjustment of the pump time delay (Pd).

If a call for heat is prevented from being satisfied either by a safety interlock or due to an ignition lockout, the red "Service" indicator on the front panel will light. To reset the standard ignition module, toggle the Pennant power switch off, and then on again. (To reset the optional single try lockout ignition module, the reset button on the module must be pressed. Interrupting power to this module will not reset the lockout.)

The Pennant 1250 through 2000 models have two ignition modules that control different burners.

### 6.3 Temperature (Operating) Control

The Pennant temperature control operates by measuring the system temperature. It also controls the Pennant pump operation and the mixing system, which tempers the water entering the heat exchanger to prevent damage from excessive condensation.

#### 6.3.1 Temperature Control Overview

The digital display on the control has the following uses:

- To display the system temperature during normal operating mode.
- To allow the user to view and adjust the control settings. There are four buttons on the controller. Top left returns to the beginning. Bottom left is the enter button. Top right is the up arrow. Bottom right is the down arrow.

The temperature control face contains an LCD screen. The LCD screen will display the system temperature during normal operation. When the control is first powered up, it displays "ZZZ". It then flashes the control software number. It then displays the temperature at the system sensor. After the temperature is displayed, the current settings (parameters) may be viewed. To scroll through the parameters, press the down arrow button to advance to the next parameter. Press the enter button to choose that parameter. Press the up or down arrow to raise, lower or toggle to value of that parameter. Press enter to save a changed value.

By depressing the upper left hand button at any time during the programming, the menu may be returned to the beginning.

After about 30 seconds of button inactivity, the display will revert back to the system temperature.

#### 6.3.2 Programming Parameters - Boilers

When the control is first turned on, it flashes "ZZZ" and then "022" to indicate that the boiler software is in the control. When the down arrow is pressed, the boiler menu is brought up.

##### rT – Boiler Return Temperature

This is a display only. This is the temperature at the boiler's inlet sensor. This is not system return temperature, as the water has been mixed with hot outlet water, for boiler protection.

##### oAt – Outdoor Air Temperature

This is a display only. This is the outdoor air temperature, if outdoor reset is used. Must use optional outdoor reset sensor (p/n 2400-021).

##### CSP – Calculated Setpoint

This is a display only. When outdoor reset is used, this is the temperature that is calculated by the control, based on the settings and conditions, which becomes the setpoint of the boiler.

##### bSP – Boiler Setpoint

This is the setpoint for rT (the boiler inlet temperature sensor). Default is 190°F. Range is from 140°F to 210°F.

##### LSP – System Setpoint

This is the setpoint for system, read at the system sensor that is placed in the system loop. Default is 180°F. Range is from 60°F to 210°F.

##### LdF – System Setpoint Differential

This is the differential for LSP. Default is 2.0°F. Range is 1°F to 30°F.

##### bdf – Boiler Setpoint Differential

This is the differential for bSP. Default is 10°F. Range is 1°F to 30°F.

##### oAr – Outdoor Reset

This enables or disables the outdoor reset function. Default is "oFF". Toggle to "on" if outdoor reset is going to be used. Must use optional outdoor reset sensor (p/n 2400-021).

##### oTo - Warm Outdoor Temperature

Upper point of reset curve, where system shutoff is desired. Default 65°F. Range is 55°F to 70°F.

##### oAC – Design Temperature

Lower point of reset curve, at which the maximum water setpoint is needed. Default is 0°F. Range is from -50°F to 60°F.

##### oAL – Minimum Setpoint

This is the minimum allowable calculated setpoint, regardless of outdoor temperature. Default is 160°F. Range is 70°F to 180°F.

**oAH – Maximum Setpoint**

This is the maximum allowable calculated setpoint, regardless of outdoor temperature. Default is 190°F. Range is 90°F to 210°F.

**rc – Reset Ratio**

The ratio of air temperature movement to water temperature movement. Sets the slope of the reset curve. Default is 1.0. Range is from 0.5 to 5.0.

**SP – Minimum Mixed Temperature**

This setting is fixed at 125°F, and cannot be change by the user.

**Pd – Pump Delay**

This is the time delay for the boiler's mounted pump. The pump will run for this delay time after the call for heat has ended. Default is 2 minutes. Range is from 0.1 minutes to 10 minutes.

**Uni - Units**

This allows the user to choose between °F (default) and °C.

**6.3.3 Programming Parameters – Water Heaters**

When the control is first turned on, it flashes “ZZZ” and then “018” to indicate that the boiler software is in the control. When the down arrow is pressed, the boiler menu is brought up.

**rT – Heater Return Temperature**

This is a display only. This is the temperature at the heater's inlet sensor. This is not system return temperature, as the water has been mixed with hot outlet water, for heater protection.

**bSP – Heater Setpoint**

This is the setpoint for rT (the heater inlet temperature sensor). Default is 140°F. Range is from 140°F to 190°F.

**LSP – System Setpoint**

This is the setpoint for system, read at the system sensor that is placed in the system loop. Default is 140°F. Range is from 60°F to 190°F.

**LdF – System Setpoint Differential**

This is the differential for LSP. Default is 2.0°F. Range is 1°F to 30°F.

**Pd – Pump Delay**

This is the time delay for the heater's mounted pump. The pump will run for this delay time after the call for heat has ended. Default is 2 minutes. Range is from 0.1 minutes to 10 minutes.

**SP – Minimum Mixed Temperature**

This setting is fixed at 125°F, and cannot be change by the user.

**bdf – Heater Setpoint Differential**

This is the differential for bSP. Default is 10°F. Range is 1°F to 30°F.

**Uni - Units**

This allows the user to choose between °F (default) and °C.

**⚠ CAUTION**

Should overheating occur or the gas supply fail to shut off, turn off the manual gas control valve to the appliance.

**6.4 Limit Controls**

Pennant appliances are fitted with an automatic reset high limit and a manual reset high limit, both sensing the outlet temperature of the Pennant.

Water heater high limits are adjustable up to 200°F (93°C) and boiler high limits are adjustable up to 240°F (116°C).

To set the limit controls, remove the control panel cover and pull the control panel out to gain access.

**6.5 Operating the Burner and Set Up****6.5.1 Set Up for 0 to 2500 Feet Altitude**

The Pennant appliance utilizes a modular design to achieve its stage-firing. The setup must be checked before the unit is put in operation. Problems such as failure to start, rough ignition, strong exhaust odors, etc. can be due to improper setup. Damage to the Pennant resulting from improper setup is not covered by the limited warranty.

1. Using this manual, make sure the installation is complete and fully in compliance with the instructions.
2. Determine that the appliance and system are filled with water and all air has been bled from both. Open all valves.
3. Observe all warnings on the Operating Instructions label and turn on gas and electrical power to appliance.
4. Switch on the appliance power switch located on the right side of the unit.
5. The Pennant will enter the start sequence, as long as the unit is being called for heat. The blower and pump come on for pre-purge, then the ignitor warm-up sequence starts and after the ignitor warm-up is complete and all safety devices are verified, the gas valves open. If ignition doesn't occur, check that there is proper gas supply. Wait 5 minutes and start the unit again. During initial start up, air in the gas line may cause the Pennant to “lock out” during the first few trials for ignition. Depending on the ignition modules installed, the manual reset button on the ignition modules may need to be depressed to restart the Pennant.
6. When the unit is running, the supply gas pressure must be checked. Inlet gas pressure must not exceed 13” W.C. (3.2kPa). The minimum inlet gas pressure is 5” W.C. (1.2kPa).
7. Once the inlet gas pressure is verified, the outlet gas pressure from each valve (manifold gas pressure) must be checked, and adjusted, if

necessary. The manifold gas pressure must be 2.5" W.C. (0.62kPa).

8. Complete the setup by checking the CO<sub>2</sub> at the outlet of the unit. The CO<sub>2</sub> should be 8% for natural gas, or 9.2% for propane.
9. **After placing the appliance in operation, the Burner Safety Shutoff Device must be tested.** To test:
  - (a) Close gas shutoff valve with burner operating.
  - (b) The flame will go out and blower will continue to run for the post purge cycle. One additional attempt to light will follow. Ignition will not occur as the gas is off. The ignition control will lockout, and will have to be reset before the unit will operate.
  - (c) Open gas shutoff valve. Restart the appliance. The ignition sequence will start again and the burner will start. The appliance will return to its previous mode of operation.

**NOTE:** Models 1250-2000 have two ignition controls and two ignitors, which work together to ensure all of the burners light properly.

### 6.5.2 High Altitude Adjustment and Set Up

Pennant appliances may be operated at high altitude (7700 ft., 2347 m) with a reduction in output of approximately 10%. At altitudes of less than or more than 7700 ft. (2347 m) the appliance will perform equally as well, but with differing reductions in output. At elevations higher than 7700 ft. (2347 m) the reduction in output will exceed 10% and at elevations below 7700 ft. (2347 m) it will be less than 10%. High altitude adjustment must not be made on appliances operating at elevations below 2500 ft. (762 m).

No orifice changes are required to adjust the Pennant appliances for high altitude. High altitude adjustment is accomplished by adjustment of the gas valve manifold pressure and the air shutter(s). The required instruments used to assist in these adjustments are a CO<sub>2</sub> or O<sub>2</sub> Analyzer and a U-Tube Manometer or other device capable of reading a pressure of 2.5-3.0 inches W.C. (0.62-0.75 kPa).

Start the adjustment process by checking the CO<sub>2</sub> in the "as installed" condition. Adjust the air shutter(s) so that the CO<sub>2</sub> is about 8% or the O<sub>2</sub> is about 6.8% for appliances operating on Natural Gas. For appliances operating on LP Gas adjust the air shutter(s) so that the CO<sub>2</sub> is about 9.2% or the O<sub>2</sub> is about 6.8%. Appliances with two blowers should be adjusted so that the air shutters below each blower are open the same amount.

Once the CO<sub>2</sub> or O<sub>2</sub> has been set, the manifold pressure may be adjusted. Remove the 1/8 NPT plug from the lower side of the gas valve that is to be set and install a fitting, hose and manometer. Start the appliance and observe the manifold pressure. Manifold pressure must be adjusted to 3.0 in. W.C. (0.75 kPa)

(for high altitude only, standard operating pressure is 2.5 in. W.C. (0.62 kPa)). It is adjusted by removing the slotted cap on the gas valve and turning the adjustment screw (beneath the cap) clockwise to increase pressure and replaced after the adjustments have been completed and the fitting, hose and manometer have been removed and the 1/8" plug has been replaced. Repeat this process until all gas valves have been set. Note: The pressure can be set only when the appliance is operating and only when the particular gas valve being adjusted is energized by a call for heat from the staging control.

After all of the gas valve manifold pressures have been set, the CO<sub>2</sub> or O<sub>2</sub> must be reset. CO<sub>2</sub> or O<sub>2</sub> will have changed when the manifold pressure was adjusted. Open the air shutter(s) to reduce the CO<sub>2</sub> or O<sub>2</sub> to the values achieved previously.

The procedure is complete when all gas valves are adjusted to a manifold pressure of 3.0 in. W.C. (0.75 kPa) and the CO<sub>2</sub> is adjusted to 8.0% for Natural Gas appliances or 9.2% for LP appliances. When using an O<sub>2</sub> analyzer, the correct O<sub>2</sub> is 6.8% for both Natural Gas and LP appliances.

#### CAUTION

Should any odor of gas be detected, or if the gas burner does not appear to be functioning in a normal manner, close main shutoff valve, do not shut off switch, and contact your heating contractor, gas company, or factory representative.

### 6.6 Shutting Down the Pennant

1. Switch off the main electrical disconnect switch.
2. Close all manual gas valves.
3. If freezing is anticipated, drain the Pennant and be sure to also protect building piping from freezing.

**This step to be performed by a qualified service person.**

### 6.7 To Restart the Pennant

If drained, follow Section 6.1 in this manual for proper filling and purging.

1. Switch off the main electrical disconnect switch.
2. Close all manual gas valves.
3. **WAIT FIVE (5) MINUTES.**
4. Set the aquastat or thermostat to its lowest setting.
5. Open all manual gas valves.
6. Reset all safety switches (pressure switch, manual reset high limit, etc.).
7. Set the temperature controller to the desired temperature setting and switch on electrical power.
8. Burner will go through a pre-purge period and ignitor warm-up period, followed by ignition.

## SECTION 7. Maintenance

### 7.1 System Maintenance

1. Lubricate the system water-circulating pump, if required, per the instructions on the pump.
2. If a strainer is employed in a pressure reducing valve or the piping, clean it every six months.
3. Inspect the venting system for obstruction or leakage at least once a year. Periodically clean the screens in the vent terminal and combustion air terminal (when used).
4. Keep the appliance area clear and free from combustible materials, gasoline, and other flammable vapors and liquids.
5. If the appliance is not going to be used for extended periods in locations where freezing normally occurs, it should be isolated from the system and completely drained of all water. All systems connected to it should also be drained or protected from freezing.
6. Low water cutoffs, if installed, should be checked every 6 months. Float type low water cutoff should be flushed periodically.
7. Inspect flue passages, and clean with brushes/vacuums, if necessary. Sooting in flue passages indicates improper combustion. Determine the cause and correct.
8. Inspect the vent system and air intake system, and if the vent system is Category III, ensure that all joints are sealed properly. If joints need to be resealed, follow venting manufacturer's instructions to clean and reseal vent system.

### 7.2 Appliance Maintenance and Component Description

Only genuine Laars replacement parts should be used.

#### ⚠ Caution

Label all wires prior to disconnection when servicing controls. Wiring errors can cause improper and dangerous operation. Verify proper operation after servicing.

#### ⚠ Attention

Lors d'entretien ou de réparation des commandes, étiquetez tous les câbles avant de les déconnecter. Des erreurs de câblage peuvent provoquer des fonctionnements incorrects et dangereux. Après toute intervention d'entretien ou de réparation, vérifiez que l'appareil fonctionne correctement.

See **Figures 17 and 18** for locations of gas train and control components.

The gas and electric controls on the appliance are engineered for long life and dependable operation, but the safety of the equipment depends on their

proper functioning. It is strongly recommended that a qualified service technician inspect the basic items listed below every year.

- |                                 |                       |
|---------------------------------|-----------------------|
| a. Ignition control             | g. High limit         |
| b. Ignitor                      | h. Pump               |
| c. Water temp. control          | i. Low water cutoff   |
| d. Automatic gas valve          | j. Relays             |
| e. Pressure switches and tubing | k. Flow switch        |
| f. Blower                       | l. Gas train          |
|                                 | m. Control components |

#### 7.2.1 Burners

Close main manual gas valve before proceeding. Checking the burners for debris - Remove the ignitor inspection panels(s) and ignitor(s) and inspect the burners through the ignitor hole(s) using a flashlight to illuminate. If there is any indication of debris on the burners that are visible, all the burners will need to be inspected more thoroughly. Remove the screws from around the front of the air box (large panel from which the ignitor inspection panel(s) were removed), and remove the large panel. Remove the gas manifold assemblies and the burner panels. Inspect the burners. Clean burners, if necessary, by blowing compressed air from the outside of the burners into the center of the burner. A dirty burner may be an indication of improper combustion or dirty combustion air. Determine the cause, and correct. Replace the burners in the reverse order

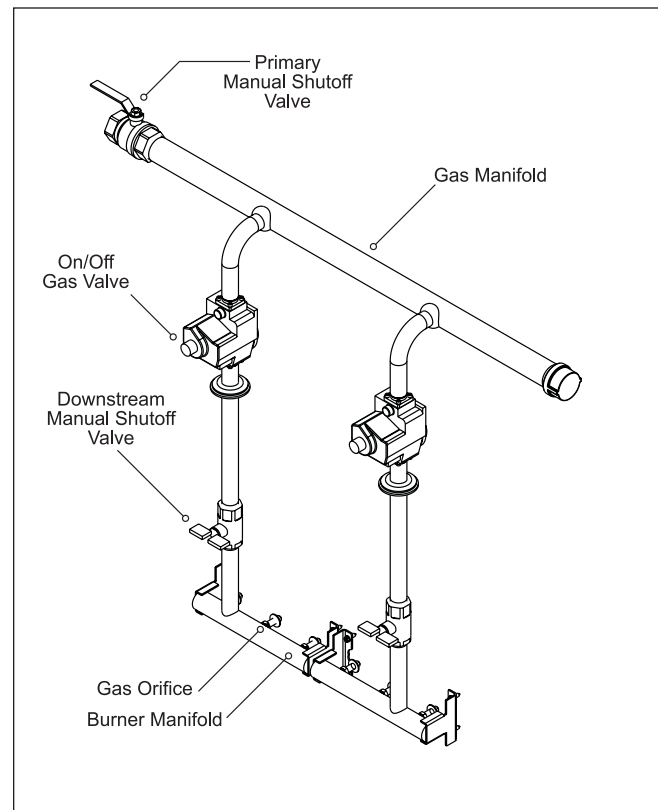

Figure 17. Gas Train Components.

**7.2.2 Filter**

The filter used in the Pennant is washable. Since the filter is washable, it will only need replacement occasionally. If filter replacement is needed, it should only be replaced with a factory part. Inspect the air filter monthly, or more often in dirty environments. If there is debris on the air filter, remove it from the filter box, and wash it with mild soap and water. Ensure that the filter is completely dry before reinstalling.

**7.2.3 Gas Valves**

The gas valves are designed to operate with supply pressures of 4-13 inches w.c. (1.0 to 3.2 kPa).

To remove a valve, shut off 120-volt power and the manual gas shutoff valve. Remove the top front panel from the unit. Disconnect the wires to the valve. Disengage the flanged fitting before and after the valve, and remove the valve. Re-install in reverse order. Ensure o-rings are properly installed for both inlet and outlet. Turn on manual gas shutoff valve and 120 volt power and check appliance operation and tightness of gas valve connections.

**7.2.4 Manual Reset High Limit Control**

The high limit switch is manual reset switch with an adjustable set point, up to 240°F (116°C) on boiler models and 200°F (93°C) on water heater models and boilers ordered with low temperature controls. To replace the switch, shut off the 120-volt power to the appliance. Remove the cover from the switch to access

the mounting screws. Remove the screws, and pull the switch off the control panel. Remove the capillary and bulb from the thermal well located in the header. Replace in reverse order.

**7.2.5 Automatic Reset High Limit Control**

An automatic reset high limit is used in addition to the manual reset high limit. The high limit switch has an adjustable set point, up to 240°F (116°C) on boiler models and 200°F (93°C) water heater models and boilers ordered with low temperature controls. To replace the switch, shut off the 120-volt power to the appliance. Remove the cover from the switch to access the mounting screws. Remove the screws, and pull the switch off the control panel. Remove the capillary and bulb from the thermal well located in the header. Replace in reverse order.

**7.2.6 Temperature Control**

The temperature control is an on/off control that also manages the mixing system.

To replace the control, disable the 120v supply power to the appliance. Unplug all of the electrical connectors, remove the retainer clip and the control. Replace the control in the reverse order.

**7.2.7 Ignition Control**

The ignition controls ensure the proved interrupted-type ignition system. They control the hot surface ignitors and prove that the flame signal is appropri-

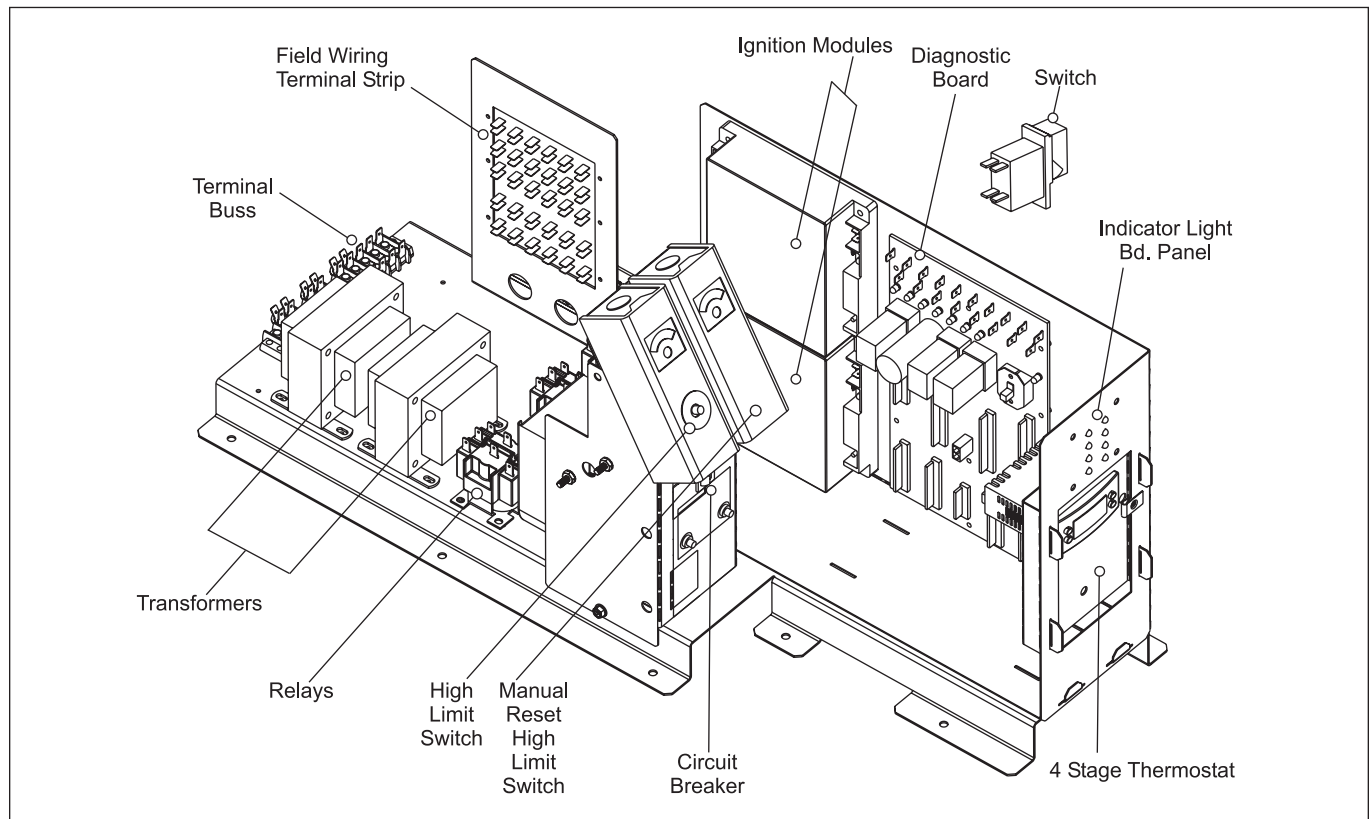

Figure 18. Typical Control Panel.

ate for powering the gas valves. It also controls the blower's pre-purge and post-purge. Pennant models 500 through 1000 have one ignition control. Models 1250 through 2000 have two ignition controls.

To replace a control, shut off the 120-volt power to the appliance. Remove the cover from the control panel. Remove the electrical connectors from the ignition control. Take out the controller's mounting screws, and pull the controller out. Replace in reverse order.

### 7.2.8 Ignitor

The ignitors used are 120v "Hot Surface" type. They are energized whenever there is a call for heat and switched off when ignition is established and the flame has been sensed. Pennant models 500 through 1000 have one ignitor. Models 1250 through 2000 have two ignitors. To replace the ignitor, shut off the 120-volt power to the appliance, remove the ignitor access panel, disconnect the Molex connector, remove the two mounting screws on the ignitor flange, and pull the ignitor out. Install in reverse order, always using a new ignitor gasket with the replacement ignitor.

#### **Caution**

Ignitor gets hot. To avoid injury, handle the ignitor with caution.

#### **Attention**

Le dispositif d'allumage devient très chaud. Manipulez le dispositif d'allumage avec précaution.

### 7.2.9 Transformer

The Pennant's transformer is not capable of supplying control voltage for external devices such as zone valves, which must have their own separate power supply.

Some Pennant units have more than one transformer, and all transformers are not the same size, so ensure that replacement transformers are the appropriate ones.

Should a transformer need replacing, shut off the 120-volt power. Unplug the transformer wires, remove the mounting screws and remove the transformer. Replace transformer in the reverse order.

### 7.2.10 Blowers

The combustion air blowers bring the combustion air for the Pennant from the upper chamber to the lower chamber. Mixing of the gas and air occurs in the burners. Models 500, to 1000 each have one blower, and models 1250 to 2000 each have two blowers.

If a blower change is required, turn off the 120-volt power and gas supply to the unit. Remove the front panel. Disconnect the blower's wire harness. Remove the screws at the blower flange, and pull the

blower out. Replace blower in reverse order, ensuring that all joints are made correctly. After replacement, ensure that the unit operates properly, by following the set-up procedure in this manual.

### 7.2.11 Flow Switch

The Pennant uses a paddle-type flow switch to ensure that the unit has water flow before ignition is allowed. To replace the flow switch, turn off the 120-volt power to the appliance. Isolate the boiler or water heater from the system by closing the isolation valves.

#### **Caution**

Water may be hot enough to scald. Allow water to cool before proceeding.

#### **Attention**

L'eau peut être chaude au point de vous brûler. Laissez refroidir l'eau avant d'intervenir.

Release pressure in the system by actuating the pressure relief valves or field supplied boiler drain valve. Remove cover from the flow switch and disconnect the wires. Unthread the flow switch from piping. Ensure the new flow switch paddles are trimmed to the same size as the original paddles, and reinstall in the reverse order. For boiler and other static pressure systems, restore the system pressure to the original setting (or 10 psi minimum).

### 7.2.12 Heat Exchanger Coil

#### **WARNING**

Black carbon soot buildup on a dirty heat exchanger can be ignited by a random spark or flame thereby creating a risk of fire or explosion. To prevent this from happening, dampen the soot deposits with a wet brush or fine water spray before servicing the heat exchanger.

#### **AVERTISSEMENT**

L'accumulation de suie sur un échangeur thermique sale peut s'enflammer au contact d'une étincelle ou d'une flamme et présenter un risque d'incendie ou d'explosion. Afin d'empêcher que cela se produise, humidifier les dépôts de suie à l'aide d'une brosse mouillée ou par une pulvérisation fine d'eau avant d'effectuer l'entretien de l'échangeur thermique.

The Pennant has a premixed burner system. These systems provide the burners with sufficient air for complete combustion, and black carbon sooting is seldom experienced. If sooting is suspected, view ports for inspection of the heat exchanger are provided on the side of the boiler. In the unlikely event that there is a buildup of black carbon soot or other debris on the heat exchanger, clean per the following:

1. Disconnect the electrical supply to the unit.
2. Turn off the gas supply by closing the manual gas valve on the heater.
3. Disconnect and remove the wires, conduit and sensors from all components that are attached to the inlet/outlet header.
4. Isolate the heat exchanger from the water supply.
5. Disconnect the header flanges from the inlet and outlet.
6. Allow the heat exchanger to drain. Remove the front cover(s) by removing the rubber access strip(s) and the retaining screws. Remove the venting and remove the top, by removing the screws that attach the top to the side panels. Remove the side panels. Remove the front lower panels sealing the combustion area. To remove the gas train, disconnect the unions located below the intermediate pan and the field installed union located outside the cabinet, and pull up, bringing the union end connectors through the grommets in the intermediate pan. To remove the intermediate pan, remove the slide out control assembly and blower(s) to reveal the screws. Remove the screws holding the intermediate pan, and lift up to remove it. The heat exchanger has integral metal sections attached, which connect to the frame of the boiler. Locate and remove the screws along the front, rear and bottom of the integral metal sections, and remove the heat exchanger and metal sections by lifting up. On the larger appliances, a center heat exchanger support must be unbolted before it can be removed.
7. Remove the heat exchanger from the unit. NOTE: Heat exchangers are heavy and may require two people to remove to avoid personal injury.
8. Clean the heat exchanger: A light accumulation of soot or corrosion on the outside of the heat exchanger can be easily removed. Use a wire brush to remove loose soot and scale from the heat exchanger.
9. NOTE: While the heat exchanger is out of the unit, inspect the firewall refractory insulation. Replace if necessary.
10. Inspect the inside of the copper tubes for scale buildup. Scale can build up on the inner surface of the heat exchanger tubes, which can restrict water flow. If the tubes show signs of scaling, clean the internal surface.
11. Reassemble in the reverse order, and check appliance operation after start-up.

**NOTE: The warranty does not cover damage caused by lack of required maintenance, lack of water flow, or improper operating practices.**

## SECTION 8. Trouble Shooting

### 8.1 Resolving Lockouts

There are many causes of lockouts. The three most common causes are: (1) inadequate gas supply, (2) poor combustion, (3) ignitor failure.

1. Inadequate gas supply: Before proceeding, ensure that the gas supply has not been shutoff or the LP tank (LP boilers) is not empty. Then, restart the boiler and observe the operational cycle. After a 15-second fan pre-purge, the ignitor will heat up for 40 seconds, and then the unit will light. If it does not, check the gas supply pressure to the appliance, after resetting the appliance and attempting another start-up. The gas pressure to the appliance must be above 5 in. w.c. (1.2 kPa) throughout the entire start-up cycle. If it is not, correct the supply problem (check gas valves or supply piping). If the supply pressure is adequate, consult the factory for assistance.
2. Poor Combustion: Poor combustion should be suspected if there is a strong flue gas odor. The odor may result from an improper gas/air ratio (high or low O<sub>2</sub> or CO<sub>2</sub>). Pennant appliances operate best with 45% excess air (8% CO<sub>2</sub> on natural gas, 9.2% CO<sub>2</sub> on LP). Check the CO<sub>2</sub> of the appliance and adjust if necessary.
3. Ignitor failure: If the boiler goes through a normal start cycle but combustion does not occur, ignitor failure should be suspected. Check the ignitor by unplugging the ignitor plug and measuring the ignitor resistance. It should be 50-80 ohms. If the resistance is not 50-80 ohms, replace the ignitor. If the resistance is correct, reset the boiler and check for 120 VAC at the ignitor plug during the start cycle. If there is no voltage, replace the faulty ignitor wire harness or the ignition control.

### 8.2 Delayed Ignition — Possible Causes

A defective burner can cause a delayed ignition. If the gas supply pressure is proper and the gas valves are functioning properly, then burners should be inspected. There should be no distortion or perforations in the burners outside of the active burner port area. Replace if indicated.

### 8.3 Short Cycling — Boiler

Boiler short cycling is caused when the load on the boiler system swings rapidly causing frequent cycling between call for heat and satisfied conditions. If short cycling is a problem, it may be due to an oversized boiler, improper control strategy, incorrect set points or a load distribution problem. The boiler controls must be set such that the heating loop temperature setpoint does not interfere with

the setpoint of the boiler operating control. If the set points are correct and the system design, controls scheme, etc. are fixed, the temperature differentials may be increased to reduce short cycling. If desired temperature response is not achievable without short cycling it may be necessary to install a buffer tank in the system. Contact your Laars representative to discuss possible remedies.

#### 8.4 Short Cycling — Water Heater

Short cycling will generally occur only in combination space heating and water heating applications when the water heater is operating in the space-heating mode. If the heating load drops below the minimum input of the water heater for an extended period, the water heater will have a tendency to short cycle. If short cycling is frequently experienced, regardless of the control's attempt to limit it, the heating load should be redistributed to control it.

If short cycling occurs in a water heater application, it is probably caused by undersized piping between the water heater and the storage tank or by some other factor that restricts proper water flow through the water heater. The cause should be determined and corrected.

#### 8.5 High Gas Consumption

Appliances operating with an improper air/fuel ratio are very inefficient and consequently, have very high gas consumption. Because efficiency is high when the CO<sub>2</sub> is high (or O<sub>2</sub> is low), appliances operating with low CO<sub>2</sub> or high O<sub>2</sub> (especially LP appliances) consume more gas. Adjust the CO<sub>2</sub> or O<sub>2</sub> for optimum efficiency. If no combustion analyzing equipment (CO<sub>2</sub> or O<sub>2</sub>) is available then a proper adjustment of the air/fuel ratio (CO<sub>2</sub> or O<sub>2</sub>) cannot be accomplished. The CO<sub>2</sub> should be 8% at high fire for natural gas and 9.2% at high fire for LP. To check the CO<sub>2</sub>, first verify that the supply gas pressure is within 5 to 13 in. w.c. (1.2 to 3.2 kPa). With the Pennant running, set the air box pressure to 1.5 in. w.c. (0.37 kPa) (as a starting point), by adjusting the air shutter(s) at the intake of the fan(s). Check the CO<sub>2</sub>, and adjust the air shutters if further adjustment to the CO<sub>2</sub> is needed.

#### 8.6 Troubleshooting Pennant Controls

A diagnostic panel, that includes test points, as well as diagnostic lights, is provided in the control module. It is located on the right side of the module, behind the display. To access, remove the retaining screws from the display cover panel and remove it. Grasp the control module at its base and pull it outward.

Pennant ladder diagrams are shown in **Figures 12 and 13**. The wiring connection diagrams are shown in **Figures 14 through 16**. The blower is energized

directly through the “inducer” terminals F1 and F2 of the (Fenwal) ignition module. The 24V power to the T<sup>+</sup>STAT terminal of both ignition modules is routed through the safety interlocks.

All 24V wiring is routed through the diagnostic PC board. Wiring harnesses connect between the diagnostic PC board and the control components, indicator board, or field wiring terminal strip. The diagnostic board contains LEDs that indicate open status of the safety interlocks, and quick-connect terminals that provide tests points for checking voltage/continuity at various points in the control circuit.

Line-voltage connections are routed via the line-voltage terminal buss. Certain control elements that may need to be rewired in the field are connected via the field wiring terminal strip rather than to the diagnostic PC board. These include the low-water cutoff (LWCO), water flow switch, and inlet/outlet water temperature sensors.

## SECTION 9.

### Replacement Parts

**Only genuine Laars replacement parts should be used.**

#### 9.1 General Information

To order or purchase parts for the Laars Pennant, contact your nearest Laars dealer or distributor. If they cannot supply you with what you need, contact Customer Service (see back cover for address, telephone and fax numbers).

#### 9.2 Parts List

See next page for the list of available replacement parts. See **Figures 19-21** for exploded views of the boiler's component systems to help identify replacements parts.

Item	Description	Size 500	Size 750	Size 1000	Size 1250	Size 1500	Size 1750	Size 2000
<b>Sheet Metal Components - See Figure 19</b>								
1	Panel, Jacket, Side Left	5C3420	5C3420	5C3420	5C3420	5C3420	5C3420	5C3420
2	Panel, Jacket, Side Right	5C3521	5C3521	5C3521	5C3521	5C3521	5C3521	5C3521
3	Panel, Jacket, Front	5C3320	7C3320	10C3320	12C3320	15C3320	17C3320	20C3320
3	Panel, Jacket, Front, Left					15C3320	17C3320	20C3320
4	Panel, Jacket, Front, Right					15C3320	17C3320	20C3320
5	Panel, Jacket, Rear	5C3220	7C3220	10C3220	12C3220	15C3220	17C3220	20C3220
5A	Panel, Jacket, Rear, Filter Enclosure					15C3026	15C3026	15C3026
6	Panel, Jacket, Top	5C3021	7C3021	10C3021	12C3021	15C3021	17C3021	20C3021
7	Panel, Jacket, Top, Left					15C3025	17C3025	20C3025
7	Panel, Jacket, Top Right					15C3025	17C3025	20C3025
8	Control Door, Access	5C3011	5C3011	5C3011	5C3011	5C3011	5C3011	5C3011
9	Plate, Gas Pipe Seal	5C3304 (2)	5C3304 (2)	10C3304 (2)	20C3304 (2)	20C3304 (2)	20C3304 (2)	20C3304 (2)
10	Plate, Cover, Wiring	5C3502	5C3502	5C3502	5C3502	5C3502	5C3502	5C3502
11	Plate, Vent	5C3004	5C3004	10C3004	20C3004	20C3004	20C3004	20C3004
12	Cover, Vent Plate				20C3006	20C3006	20C3006	20C3006
13	Plate, Cover, Filter	5C3002	5C3002	5C3002	20C3002	20C3002	20C3002	20C3002
14	Collar, Vent	5C3106	10C3100	10C3100	15C3100	15C3100	20C3100	20C3100
16	Air Filter	R2014700 (1)	R2014700 (1)	R2014700 (1)	R2014700 (2)	R2014700 (2)	R2014700 (2)	R2014700 (2)
16A	Trim, Jacket, Front	5C3019	7C3019	10C3019	12C3019	15C3019	17C3019	20C3019
16B	Housing, Rain Shield, Pump	5C3015	5C3015	5C3015	5C3015	5C3015	5C3015	5C3015
16C	Cover, Housing, Pump	5C3016	5C3016	5C3016	5C3016	5C3016	5C3016	5C3016
16D	Bracket, Support, Pump Cover	5C3017	5C3017	5C3017	5C3017	5C3017	5C3017	20C3017
<b>Internal Components - See Figures 20 and 21</b>								
17	Base Assembly	5C1020	7C1020	10C1020	12C1020	15C1020	17C1020	20C1020
18	Chamber, Front	5C2003	7C2003	10C2003	12C2003	15C2003	17C2003	20C2003
18A	Chamber, Left Side, Front	5C2015	5C2015	5C2015	5C2015	5C2015	5C2015	5C2015
18B	Chamber, Right Side, Front	5C2016	5C2016	5C2016	5C2016	5C2016	5C2016	5C2016
19	Chamber, Rear	5C2006	7C2006	10C2006	12C2006	15C2006	17C2006	20C2006
20	Chamber Assembly, Left, Bottom	5C2602	5C2602	5C2602	5C2602	5C2602	5C2602	5C2602
21	Chamber Assembly, Right, Bottom	5C2200	5C2200	5C2200	5C2200	5C2200	5C2200	5C2200
22	Chamber, Top	5C2001	7C2001	10C2001	12C2001	15C2001	17C2001	20C2001
23	Chamber, Side, Top	5C2002	5C2002	5C2002	5C2002	5C2002	5C2002	5C2002
24	Exhaust Plenum	5C2007	10C2007	10C2007	20C2007	20C2007	20C2007	20C2007
25	Bracket, Chamber, Front	5C2009	7C2009	10C2009	10C2009	10C2009	10C2009	10C2009

Item	Description	Size	Size	Size	Size	Size	Size	Size	Size
26	Bracket, Chamber, Front Left	500	750	1000	1250	1500	1750	2000	2000
27	Bracket, Chamber, Front Right				12C2011	15C2011	17C2011	20C2011	20C2011
27A	Divider, Chamber, Front				12C2009	15C2009	17C2009	20C2009	20C2009
27B	Divider, Upper, Chamber, Front				15C2005	15C2005	15C2010	20C2002	20C2002
28	Divider, Lower, Chamber, Front	5C2004	7C2004		15C2002	15C2002			
29	Cover, Chamber								
30	Cover, Chamber, Front Left	5C2005	5C2005	10C2004	12C2010	15C2004	17C2010	20C2010	20C2010
32	Door, Chamber Access	(1)	(1)	(1)	5C2005	5C2005	5C2005	5C2005	5C2005
33	Cover, Chamber, Front Right	(2)	(2)	(2)	(2)	(2)	(2)	(2)	(2)
34	Ignitor, Hot Surface, with Gasket	2400-286	2400-286	2400-286	2400-286	2400-286	2400-286	2400-286	2400-286
35	Tile, Side (Right and Left)	T2015600	T2015600	T2015600	T2015600	T2015600	T2015600	T2015600	T2015600
35A	Tile, Front	(2)	(2)	(2)	(2)	(2)	(2)	(2)	(2)
35B	Tile, Front, Left Side	T2017300							
35A	Tile, Front, Right Side	(1)							
36	Tile, Rear, Left Side								
37	Tile, Rear, Right Side								
37A	Tile, Front, Center	T2016200	T2016800	T2016800	T2016800	T2016800	T2016800	T2016800	T2016800
37B	Tile, Rear, Center	(1)	(1)	(1)	(1)	(1)	(1)	(1)	(1)
38	Tile, Rear	T2016300							
39	Tile, Rear, Left Side	(1)							
39A	Tile, Rear, Right Side								
39B	Tile, Bottom, Center								
39A	Tile, Bottom, Left Side	T2017500	T2016600	T2016600	T2016600	T2016600	T2016600	T2016600	T2016600
39B	Tile, Bottom, Right Side	(1)	(1)	(1)	(1)	(1)	(1)	(1)	(1)
39C	Tile, Bottom, Right Side	T2016600	T2018100	T2018100	T2018100	T2018100	T2018100	T2018100	T2018100
39D	Tile, Bottom, Center	(1)	(1)	(1)	(1)	(1)	(1)	(1)	(1)
39E	Tile, Bottom, Left Side								
39F	Tile, Bottom, Right Side								
39G	Tile, Bottom, Center								
39H	Tile, Bottom, Left Side	T2017200	T2017200	T2017200	T2017200	T2017200	T2017200	T2017200	T2017200
39I	Tile, Bottom, Right Side	(1)	(1)	(1)	(1)	(1)	(1)	(1)	(1)
39J	Tile, Bottom, Center								
39K	Tile, Bottom, Left Side	T2015700							
39L	Tile, Bottom, Right Side	(1)							
39M	Tile, Bottom, Center								
39N	Tile, Bottom, Left Side	T2017400	T2017400	T2017400	T2017400	T2017400	T2017400	T2017400	T2017400
39O	Tile, Bottom, Right Side	(1)	(1)	(1)	(1)	(1)	(1)	(1)	(1)
39P	Tile, Bottom, Center								
39Q	Tile, Bottom, Left Side	T2016500	T2017400	T2017400	T2018000	T2017400	T2018000	T2017400	T2017400
39R	Tile, Bottom, Right Side	(1)	(1)	(1)	(1)	(1)	(1)	(1)	(1)
39S	Tile, Bottom, Center								
39T	Tile, Bottom, Left Side	T2015900	T2015900	T2015900	T2015900	T2015900	T2015900	T2015900	T2015900
39U	Tile, Bottom, Right Side	(1)	(1)	(1)	(1)	(1)	(1)	(1)	(1)
39V	Tile, Bottom, Center								
39W	Tile, Bottom, Left Side	T2015700							
39X	Tile, Bottom, Right Side	(1)							
39Y	Tile, Bottom, Center								
39Z	Tile, Bottom, Left Side	T2015500							
39AA	Tile, Bottom, Right Side	(1)							
39AB	Tile, Bottom, Center								
39AC	Tile, Bottom, Left Side	T2017400	T2017400	T2017400	T2017400	T2017400	T2017400	T2017400	T2017400
39AD	Tile, Bottom, Right Side	(1)	(1)	(1)	(1)	(1)	(1)	(1)	(1)
39AE	Tile, Bottom, Center								
39AF	Tile, Bottom, Left Side	T2018000	T2018000	T2018000	T2018000	T2018000	T2018000	T2018000	T2018000
39AG	Tile, Bottom, Right Side	(1)	(1)	(1)	(1)	(1)	(1)	(1)	(1)
39AH	Tile, Bottom, Center								
39AI	Tile, Bottom, Left Side	T2015900	T2015900	T2015900	T2015900	T2015900	T2015900	T2015900	T2015900
39AJ	Tile, Bottom, Right Side	(1)	(1)	(1)	(1)	(1)	(1)	(1)	(1)
39AK	Tile, Bottom, Center								
39AL	Tile, Bottom, Left Side	T2015900	T2015900	T2015900	T2015900	T2015900	T2015900	T2015900	T2015900
39AM	Tile, Bottom, Right Side	(1)	(1)	(1)	(1)	(1)	(1)	(1)	(1)
39AN	Tile, Bottom, Center								
39AO	Tile, Bottom, Left Side	T2015900	T2015900	T2015900	T2015900	T2015900	T2015900	T2015900	T2015900
39AP	Tile, Bottom, Right Side	(1)	(1)	(1)	(1)	(1)	(1)	(1)	(1)
39AQ	Tile, Bottom, Center								
39AR	Tile, Bottom, Left Side	T2015900	T2015900	T2015900	T2015900	T2015900	T2015900	T2015900	T2015900
39AS	Tile, Bottom, Right Side	(1)	(1)	(1)	(1)	(1)	(1)	(1)	(1)
39AT	Tile, Bottom, Center								
39AU	Tile, Bottom, Left Side	T2015900	T2015900	T2015900	T2015900	T2015900	T2015900	T2015900	T2015900
39AV	Tile, Bottom, Right Side	(1)	(1)	(1)	(1)	(1)	(1)	(1)	(1)
39AW	Tile, Bottom, Center								
39AX	Tile, Bottom, Left Side	T2015900	T2015900	T2015900	T2015900	T2015900	T2015900	T2015900	T2015900
39AY	Tile, Bottom, Right Side	(1)	(1)	(1)	(1)	(1)	(1)	(1)	(1)
39AZ	Tile, Bottom, Center								
39BA	Tile, Bottom, Left Side	T2015900	T2015900	T2015900	T2015900	T2015900	T2015900	T2015900	T2015900
39BB	Tile, Bottom, Right Side	(1)	(1)	(1)	(1)	(1)	(1)	(1)	(1)
39BC	Tile, Bottom, Center								
39BD	Tile, Bottom, Left Side	T2015900	T2015900	T2015900	T2015900	T2015900	T2015900	T2015900	T2015900
39BE	Tile, Bottom, Right Side	(1)	(1)	(1)	(1)	(1)	(1)	(1)	(1)
39BF	Tile, Bottom, Center								
39BG	Tile, Bottom, Left Side	T2015900	T2015900	T2015900	T2015900	T2015900	T2015900	T2015900	T2015900
39BH	Tile, Bottom, Right Side	(1)	(1)	(1)	(1)	(1)	(1)	(1)	(1)
39BI	Tile, Bottom, Center								
39BJ	Tile, Bottom, Left Side	T2015900	T2015900	T2015900	T2015900	T2015900	T2015900	T2015900	T2015900
39BK	Tile, Bottom, Right Side	(1)	(1)	(1)	(1)	(1)	(1)	(1)	(1)
39BL	Tile, Bottom, Center								
39BL	Tile, Bottom, Left Side	T2015900	T2015900	T2015900	T2015900	T2015900	T2015900	T2015900	T2015900
39BM	Tile, Bottom, Right Side	(1)	(1)	(1)	(1)	(1)	(1)	(1)	(1)
39BN	Tile, Bottom, Center								
39BO	Tile, Bottom, Left Side	T2015900	T2015900	T2015900	T2015900	T2015900	T2015900	T2015900	T2015900
39BP	Tile, Bottom, Right Side	(1)	(1)	(1)	(1)	(1)	(1)	(1)	(1)
39BQ	Tile, Bottom, Center								
39BQ	Tile, Bottom, Left Side	T2015900	T2015900	T2015900	T2015900	T2015900	T2015900	T2015900	T2015900
39BR	Tile, Bottom, Right Side	(1)	(1)	(1)	(1)	(1)	(1)	(1)	(1)
39BS	Tile, Bottom, Center								
39BS	Tile, Bottom, Left Side	T2015900	T2015900	T2015900	T2015900	T2015900	T2015900	T2015900	T2015900
39BT	Tile, Bottom, Right Side	(1)	(1)	(1)	(1)	(1)	(1)	(1)	(1)
39BU	Tile, Bottom, Center								
39BU	Tile, Bottom, Left Side	T2015900	T2015900	T2015900	T2015900	T2015900	T2015900	T2015900	T2015900
39BV	Tile, Bottom, Right Side	(1)	(1)	(1)	(1)	(1)	(1)	(1)	(1)
39BV	Tile, Bottom, Center								
39BV	Tile, Bottom, Left Side	T2015900	T2015900	T2015900	T2015900	T2015900	T2015900	T2015900	T2015900
39BW	Tile, Bottom, Right Side	(1)	(1)	(1)	(1)	(1)	(1)	(1)	(1)
39BW	Tile, Bottom, Center								
39BW	Tile, Bottom, Left Side	T2015900	T2015900	T2015900	T2015900	T2015900	T2015900	T2015900	T2015900
39BX	Tile, Bottom, Right Side	(1)	(1)	(1)	(1)	(1)	(1)	(1)	(1)
39BX	Tile, Bottom, Center								
39BX	Tile, Bottom, Left Side	T2015900	T2015900	T2015900	T2015900	T2015900	T2015900	T2015900	T2015900
39BY	Tile, Bottom, Right Side	(1)	(1)	(1)	(1)	(1)	(1)	(1)	(1)
39BY	Tile, Bottom, Center								
39BY	Tile, Bottom, Left Side	T2015900	T2015900	T2015900	T2015900	T2015900	T2015900	T2015900	T2015900
39BZ	Tile, Bottom, Right Side	(1)	(1)	(1)	(1)	(1)	(1)	(1)	(1)
39BZ	Tile, Bottom, Center								
39BZ	Tile, Bottom, Left Side	T2015900	T2015900	T2015900	T2015900	T2015900	T2015900	T2015900	T2015900
39C0	Tile, Bottom, Right Side	(1)	(1)	(1)	(1)	(1)	(1)	(1)	(1)
39C0	Tile, Bottom, Center								
39C0	Tile, Bottom, Left Side	T2015900	T2015900	T2015900	T2015900	T2015900	T2015900	T2015900	T2015900
39C1	Tile, Bottom, Right Side	(1)	(1)	(1)	(1)	(1)	(1)	(1)	(1)
39C1	Tile, Bottom, Center								
39C1	Tile, Bottom, Left Side	T2015900	T2015900	T2015900	T2015900	T2015900	T2015900	T2015900	T2015900
39C2	Tile, Bottom, Right Side	(1)	(1)	(1)	(1)	(1)	(1)	(1)	(1)
39C2	Tile, Bottom, Center								
39C2	Tile, Bottom, Left Side	T2015900	T2015900	T2015900	T2015900	T2015900	T2015900	T2015900	T2015900
39C3	Tile, Bottom, Right Side	(1)	(1)	(1)	(1)	(1)	(1)	(1)	(1)
39C3	Tile, Bottom, Center								
39C3	Tile, Bottom, Left Side	T2015900	T2015900	T2015900	T2015900	T2015900	T2015900	T2015900	T2015900
39C4	Tile, Bottom, Right Side	(1)	(1)	(1)	(1)	(1)	(1)	(1)	(1)
39C4	Tile, Bottom, Center								
39C4	Tile, Bottom, Left Side	T2015900	T2015900	T2015900	T2015900	T2015900	T2015900	T2015900	T2015900
39C5	Tile, Bottom, Right Side	(1)	(1)	(1)	(1)	(1)	(1)	(1)	(1)
39C5	Tile, Bottom, Center								
39C5	Tile, Bottom, Left Side	T2015900	T2015900	T2015900	T2015900	T20			

Item	Description	Size 500	Size 750	Size 1000	Size 1250	Size 1500	Size 1750	Size 2000
41	Heat Exchanger, Copper	R2014901	R2014902	R2014903	R2026701	R2014904	R2026702	R2014905
	Heat Exchanger, Cupro-Nickel	R2027801	R2027802	R2027803	R2027804	R2027805	R2027806	R2027807
42	Water Barrier, Inlet/outlet	20305101	20305101	20305101	20305101	20305101	20305101	20305101
43	Water Barrier, Inlet	10338300	10338300	10338300	10338300	10338300	10338300	10338300
44	Gasket, Header	S0095100 (2)	S0095100 (2)	S0095100 (2)	S0095100 (2)	S0095100 (2)	S0095100 (2)	S0095100 (2)
45	Cover, In/Out, Glass-lined Cast Iron	10364504	10364504	10364504	10364504	10364504	10364504	10364504
	Cover, In/Out, Bronze	10364501	10364501	10364501	10364501	10364501	10364501	10364501
46	Well, Temperature Control	RE2058300	RE2058300	RE2058300	RE2058300	RE2058300	RE2058300	RE2058300
47	Gasket, Flange	S0063700 (2)	S0063700 (2)	S0063700 (2)	S0063700 (2)	S0063700 (2)	S0063700 (2)	S0063700 (2)
48	Flange, Cast Iron	10391302	10391302	10391302	10391302	10391302	10391302	10391302
	Flange, Bronze	20255401	20255401	20255401	20255401	20255401	20255401	20255401
49	Relief Valve, PNCH, 75 PSI	A0063300	A0063600	A0063600	A0063600	A0063600	A0063600	A0002700
	Relief Valve, PNCV, 125 PSI	RA0001200	RA0001200	RA0001200	RA0001200	A0064400	A0064400	A0066400
50	Tee, Adapter, Outlet, Cast Iron	20130001	20130001	20130001	20130002	20130002	20130002	20130002
	Tee, Adapter, Outlet, Bronze	20150301	20150301	20150301	20150301	20150301	20150301	20150303
51	Flow Switch	RE0013000	RE0013000	RE0013000	RE0013000	RE0013000	RE0013000	RE0013000
52	Gauge, Temperature/Pressure	RA0079000	RA0079000	RA0079000	RA0079000	RA0079000	RA0079000	RA0079000
54	Low Water Cutoff	R0021901	R0021901	R0021901	R0021901	R0021901	R0021901	R0021901
55	Pump Housing, Glass-lined, Cast Iron	R20607600	R20607600	R20607600	R20607600	R20607600	R20607600	R20607600
	Pump Housing, Bronze	10483300	10483300	10483300	10483300	10483300	10483300	10483300
56	Gasket, Pump Adapter	S0024600	S0024600	S0024600	S0024600	S0024600	S0024600	S0024600
57	Pump Adapter, Glass-lined Cast Iron	10364200	10364200	10364200	10364200	10364200	10364200	10364200
	Pump Adapter, Bronze	10364201	10364201	10364201	10364201	10364201	10364201	10364201
58	Baffle, Diffuser, Pump Inlet	10338400	10338400	10338400	10338400	10338400	10338400	10338400
59	Pressure Switch	RE0240900 (2)	RE0240900 (2)	RE0240900 (2)	RE0240900 (3)	RE0240900 (3)	RE0240900 (3)	RE0240900 (3)
60	Blower	A2111900 (1)	A2111900 (1)	A2111900 (1)	A2111900 (2)	A2111900 (2)	A2111900 (2)	A2111900 (2)
61	Weldment, Blower Mount	5C5300 (1)	5C5300 (1)	5C5300 (1)	5C5300 (2)	5C5300 (2)	5C5300 (2)	5C5300 (2)
62	Damper, Duct Assembly, Blower	15C5400 (2)	15C5400 (2)	15C5400 (2)	15C5400 (2)	15C5400 (2)	15C5400 (2)	15C5400 (2)
<b>Electrical Components - See Figure 21A</b>								
64	Bracket, Control Panel Mounting	5C7103	5C7103	5C7103	5C7103	5C7103	5C7103	5C7103
65	Terminal Board, Field Wiring	E2307400	E2307401	E2307402	E2307403	E2307404	E2307405	E2307406





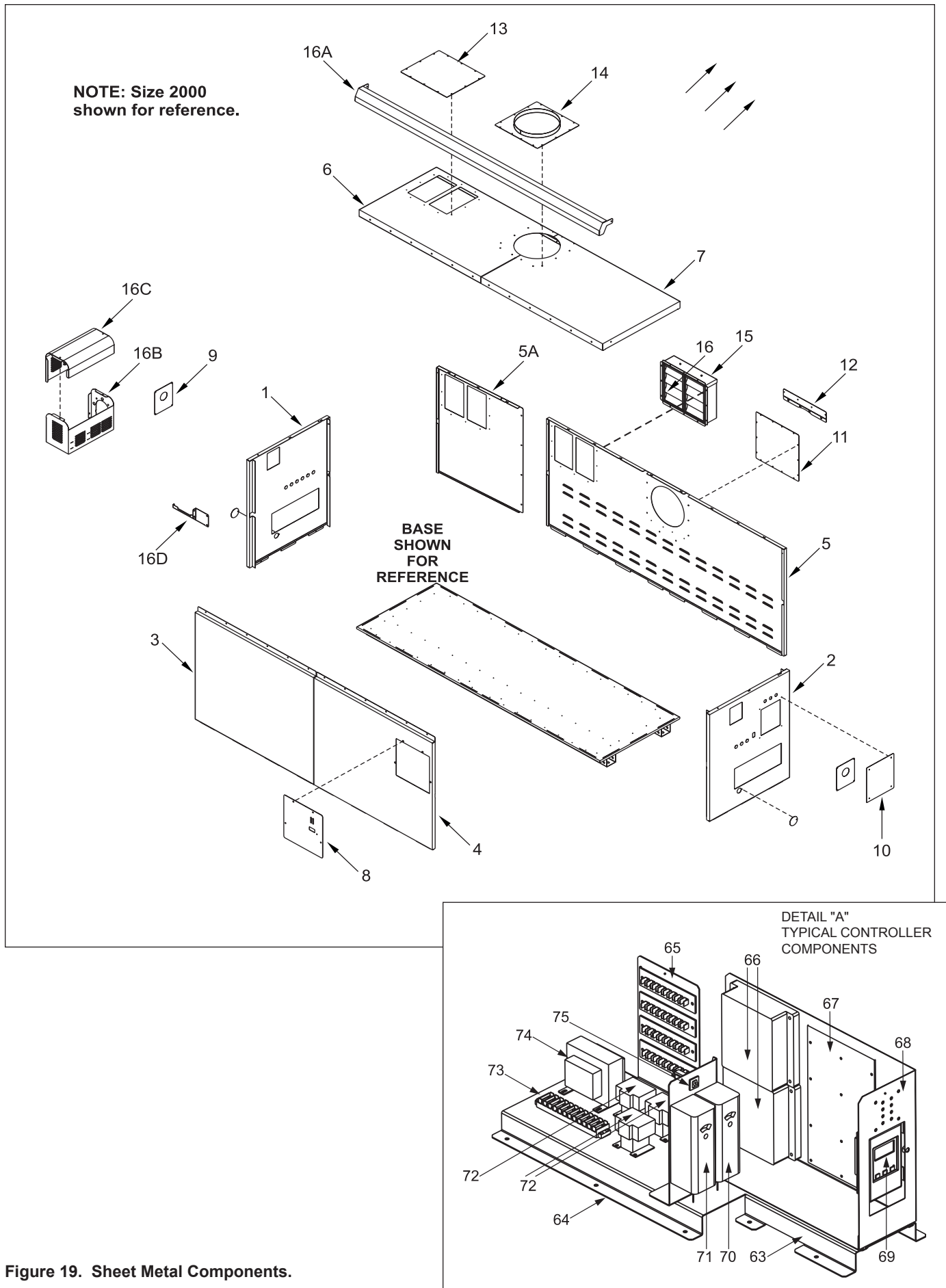
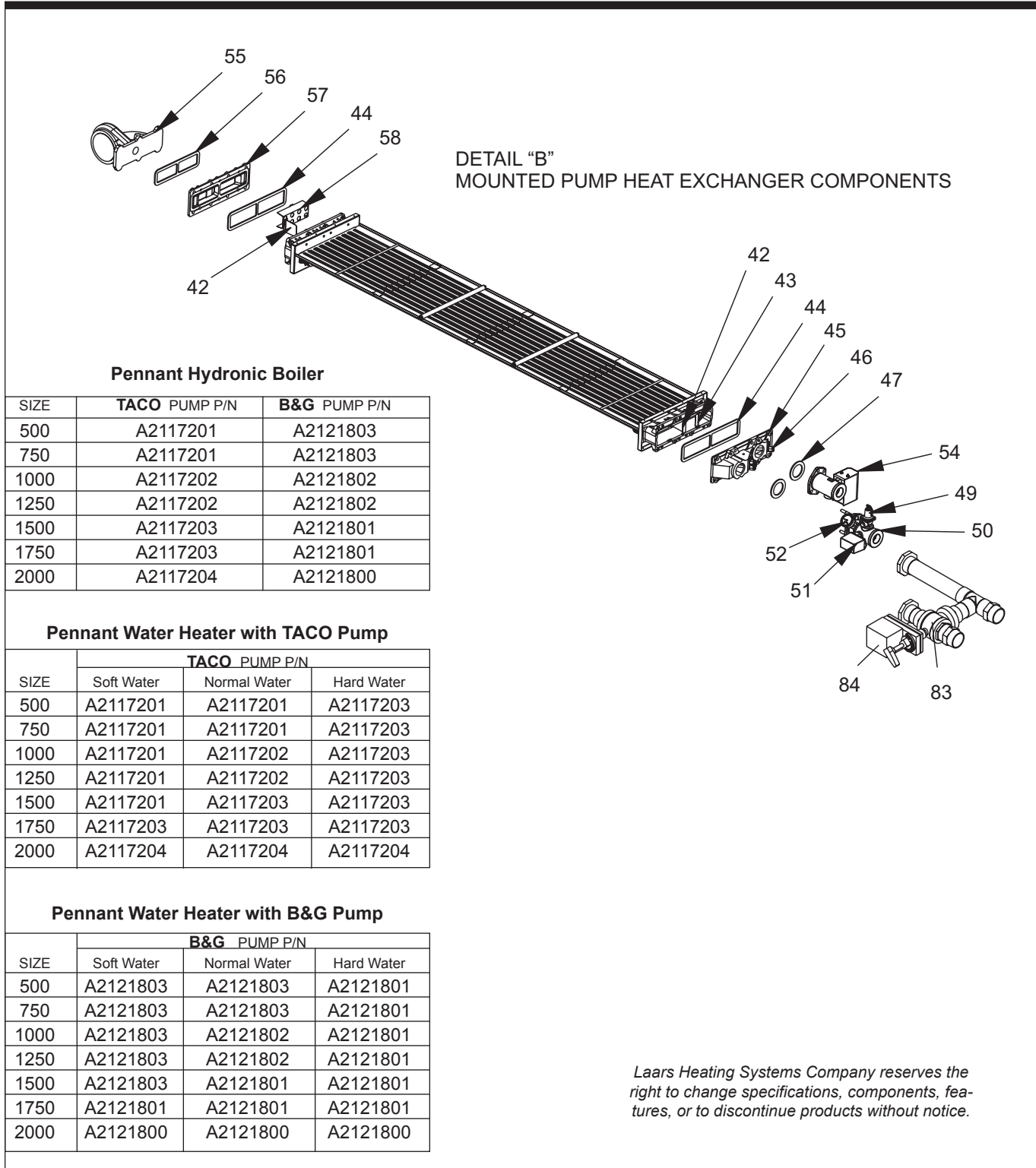

Figure 19. Sheet Metal Components.





**Figure 21. Detail of Internal Components.**



H2319100E