

Installation/User Manual

BECON HVAC BACnet

- Make sure to read the cautions for safety before installation and use, and use it correctly.
- It is intended to keep protect the safety of the installer and user and to prevent the property damage, etc.
- After reading the user manual, please keep it at a place where user can access any time.

Model Name: BACnet Gateway (ACP BACnet)

Model No.: PQNFB17C1, PQNFB17C0



P/NO : MFL67709501

www.lg.com

EXPLANATORY NOTES

Copyrights

The contents of this ACP BACnet User Guide are protected by international copyright laws, and the Computer Program Protection Act. The contents of the User Guide and the programs mentioned herein may only be used under license from LG Electronics in strict adherence to the user agreement.

You may not reproduce or distribute, by any means, copies of this User Guide, or any part of it, without prior approval from LG Electronics.

Copyright © 2014 LG Electronics. All rights reserved.

Registered Trademarks

ACP BACnet is a registered trademark of LG Electronics. All other products and company names are trademarks of their respective owners and are used for illustrative purposes only.

TIPS FOR SAVING ENERGY

Here are some tips that will help you minimize the power consumption when you use the air conditioner. You can use your air conditioner more efficiently by referring to the instructions below:

- Do not cool excessively indoors. This may be harmful for your health and may consume more electricity.
- Block sunlight with blinds or curtains while you are operating the air conditioner.
- Keep doors or windows closed tightly while you are operating the air conditioner.
- Adjust the direction of the air flow vertically or horizontally to circulate indoor air.
- Speed up the fan to cool or warm indoor air quickly, in a short period of time.
- Open windows regularly for ventilation as the indoor air quality may deteriorate if the air conditioner is used for many hours.
- Clean the air filter once every 2 weeks. Dust and impurities collected in the air filter may block the air flow or weaken the cooling / dehumidifying functions.



Notes

The product images and descriptions included in this manual are stated based on ACP BACnet Free volt (Model No.: PQNFB17C0).

- ACP BACnet Free volt (PQNFB17C0)
- ACP BACnet 24V (PQNFB17C1)

For your records

Staple your receipt to this page in case you need it to prove the date of purchase or for warranty purposes. Write the model number and the serial number here:

Model number : _____

Serial number : _____

You can find them on a label on the side of each unit.

Dealer's name : _____

Date of purchase : _____

IMPORTANT SAFETY INSTRUCTIONS

READ ALL INSTRUCTIONS BEFORE USING THE APPLIANCE.

Always comply with the following precautions to avoid dangerous situations and ensure peak performance of your product



WARNING

It can result in serious injury or death when the directions are ignored.



CAUTION

It can result in minor injury or product damage when the directions are ignored.



WARNING

- Installation or repairs made by unqualified persons can result in hazards to you and others.
- Installation **MUST** conform with local building codes or, in the absence of local codes, with the Nation Electrical Code NFPA 70/ANSI C1-1003 or current edition and Canadian Electrical Code Part1 CSA C.22.1.
- The information contained in the manual is intended for use by a qualified service technician familiar with safety procedures and equipped with the proper tools and test instruments.
- Failure to carefully read and follow all instructions in this manual can result in equipment malfunction, property damage, personal injury and/or death.

Installation

- **Any question about the product installation should be asked to the service center or the professional installation agency.**
 - It may cause fire, electric shock, explosion or injury.
- **Consult the service center or the professional installation agency about reinstalling the installed product.**
 - It may cause fire, electric shock, explosion or injury.
- **Please use the standardized parts.**
 - It may cause fire, electric shock, explosion, injury, or failure.
- **Do not keep or use combustible gas or inflammable material near the product.**
 - IT may cause fire or electric shock.
- **Do not disassemble, repair or modify the product at random.**
 - It may cause failure of the product.
- **Do not install where raindrop can fall.**
 - It may cause failure of the product.

- **Do not install the product at wet place.**
 - It may cause failure of the product.
- **Provided product and adaptor shall only be installed and used inside a building.**
 - It may cause fire or failure of the product.
*Do not install or use outside.
- **Install stably in a place that can endure the weight of the ACP BACnet.**
 - If the installation place is not strong enough, the ACP BACnet may fall and damaged.
- **Make sure to enquire to the specialty store of the product purchase or service center for electric works.**
 - It may cause fire or electric shock.
- **Do not damage the power cord or bend it by force.**
 - It may cause fire or electric shock.
- **You need to use a safely insulated power supply which follows IEC61558-2-6 and NEC Class2**
 - If you do not follow, It may cause fire, electric shock, explosion or injury.
- **Do not connection 220V power to 24V products**
 - If you do not follow, It may cause fire, electric shock, explosion or injury.
- **Do not connect power cord to the control signal connector.**
 - It may cause fire or explosion.

Operation

- **Do not change or extend the power cord with your own discretion.**
 - It may cause fire or electric shock
- **Do not place any heating device near the product.**
 - It may cause fire.
- **Do not use any heating device near the power cord.**
 - It may cause fire or electric shock.
- **Do not let water flow into the product.**
 - It may cause electric shock or failure.
- **Do not put heavy weight on the power cord.**
 - It may cause fire or electric shock.
- **Do not put heavy weight on the product.**
 - It may cause the failure of the product.
- **If the product is flooded, consult the service center or the professional installation agency.**
 - It may cause fire or electric shock.

- **Let the children or the old and the weak be controlled by the guardian to use.**
 - It may cause accident or failure.
- **Do not give any shock to the product.**
 - Any shock to the product may cause failure.
- **Grab the head of the plug of the power cord to pull when disconnecting the plug, and do not click the plug with wet hands.**
 - It may cause fire or to deform the product.
- **Do not use the product in certain environments as follows.**
 - If the product is used in a place with oil, steam, or sulfuric acid gas, performance may be degraded or product may be damaged.
- **Do not press the switch or button with sharp objects.**
 - It may cause electric shock or failure of the product.
- **Please check the operation temperature.**
 - If the product is used in an environment with the temperature exceeding the operation boundary, it may cause a severe damage.
Please check the usage temperature boundary in the manual. If there is no specified temperature, please use the product within the boundary of 0~40 °C.
- **Do not put a container, etc. with water on the product.**
 - It may cause fire or electric shock.
- **Do not click the switch with wet hand.**
 - It may cause electric shock or failure of the product.
- **Please read installation and user manual for connection with PC or peripheral devices.**
 - It may cause fire or failure of the product.
- **If a warning window appears on PC, product stops, or it does not work, immediately stop the usage.**
 - It may cause fire or failure of the product.



CAUTION

Operation

- **Do not use strong detergent such as solvent, but a soft cloth.**
 - It may cause fire or to deform the product.
- **Please check the rated capacity of the power.**
 - It may cause fire or failure of the product.

 MEMO

TABLE OF CONTENTS

1 ACP BACnet FUNCTIONS AND SPECIFICATION

- 1 ACP BACnet Functions
- 3 ACP BACnet Components
- 4 Names of each part of ACP BACnet
- 6 ACP BACNET HARDWARE SPECIFICATION

7 INSTALLING ACP BACnet

- 7 Installing ACP BACnet
- 8 Check points during the ACP BACnet installation
- 10 Setting the indoor unit address
- 12 Setting the PI485 and connecting the cable
- 14 Installing ACP BACnet and connecting cables
- 20 Setting the ACP BACnet network address
- 29 Setting the functions of the ACP BACnet

44 LG'S ACP BACnet AGREEMENT

46 FUNCTIONAL SPECIFICATIONS ACP BACnet

81 NOTES

- 81 Troubleshooting
- 85 OPEN SOURCE SOFTWARE NOTICE
- 86 BIBBs
- 95 ACP-BACnet Error Response Table

 MEMO

ACP BACnet FUNCTIONS AND SPECIFICATION

ACP BACnet is the central controller that can manage up to 256 equipments in one space individually or as combined. ACP BACnet can monitor or control the equipments installed in each room of the building from the places such as the management office of a building or the administration office of a school.

ACP BACnet Functions

Major functions of the ACP BACnet are as follows.

Environment setting function using the ACP BACnet external buttons ACP BACnet can use the external buttons installed outside of the ACP BACnet to set the following functions.

- Set Network environment (IP address, Net mask, Gateway)
- Set the function to use between Peak/demand function
- SW upgrade function
- Data backup function
- Data recovery function
- RS-485 communication logging function
- Fahrenheit/Celsius setting function
- Device ID setting function
- Vnet number setting function
- Foreign Device register function

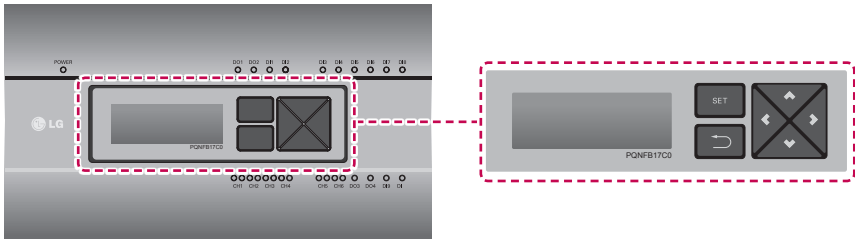

Embedded web server function

Using Internet Explorer, the central control program in ACP BACnet web server is automatically run, and the functions of various contents can be used.

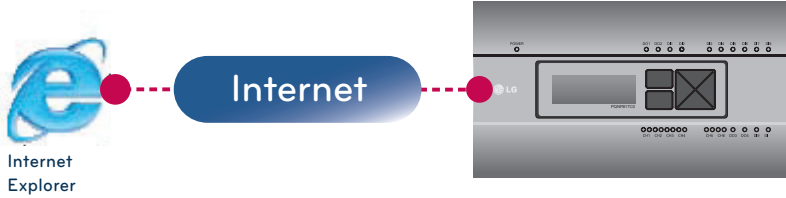

- Controlling of up to 256 air conditioner indoor units (ACS I/O Interlocking : Control up to 128 indoor units and 16 I/O modules)
- Monitoring of error and operation status
- Controlling the peak power / demand power
- System setting function

Devices that can interface with ACP BACnet

Device	ACP BACnet
AC Ez	o
Simple Central Controller	o
AC Smart IV	o
AC Manager IV	o
Air Conditioner	o
ERV	o
AWHP	o
Remote Shutdown	o
Chiller	x
AHU	o
ACS I/O	o

ACP BACnet Components

Inside the packaged box of the ACP BACnet, there are the components as in the following drawing. Open the packaged box of the ACP BACnet, and check if all of the corresponding components are included.

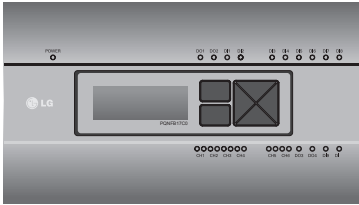

ACP BACnet

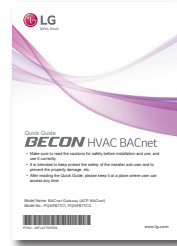

Quick Guide

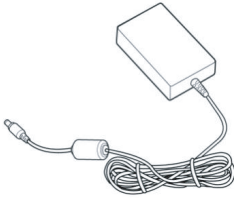

Power Supply Adaptor
 Input: 100-240 V~
 50/60 Hz, 1.2 A
 Output: DC 12 V
 3.33 A, 40 W MAX

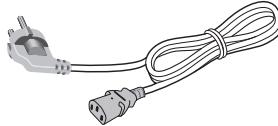

Power Cord
 250 V~, 3A



ACP BACnet Installation/User
 Manual CD

! **Notes**
 Power Supply Adaptor and Power Cord are not included in PQNFB17C1.

Names of each part of ACP BACnet

ACP BACnet is composed as follows.

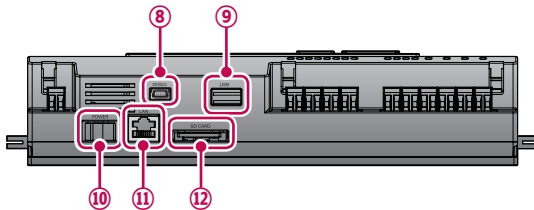
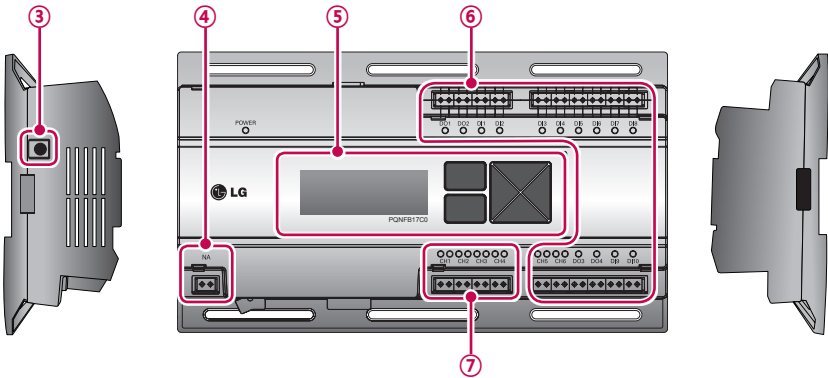
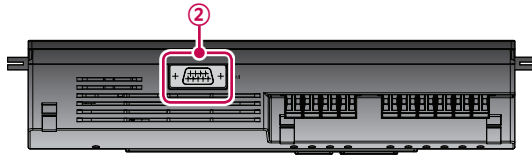
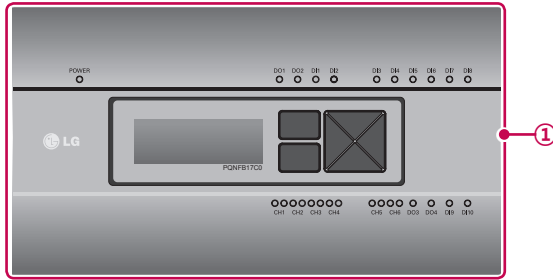

! Notes

③ and ④ may be different for each model.

Number	Item	Description
①	Cover	Front cover of the ACP BACnet
②	RS-232 console port	Reserved communication port
③	Adaptor connection jack	Jack for DC 12 V to connect to the power supply adaptor (not supported by PQNFB17C1.)
④	Power port	24 V~ port for power connection (not supported by PQNFB17C0)
⑤	Buttons and LCD	Buttons and LCD to set network environment and to display other information
⑥	Optional input/output and RS-485 communication port	Connection port to connect to external input/output signals and RS-485 communication port for external expansion. (10 DI's, 4 DO's, 2 RS-485 communication ports)
⑦	RS-485 communication port	RS-485 communication ports to connect to air conditioner and ERV equipment (4 in total)
⑧	Mini USB port	USB to Serial port for software debugging
⑨	USB port	For software update and data backup
⑩	Power switch	Switch to turn on or off the power of the ACP BACnet
⑪	Ethernet port	Ethernet port to connect to internet and AC Manager IV
⑫	SD card slot	For RS-485 communication data backup.



Caution

If four times the power connector for the connection, as shown by using the right connection, but please note that an electric shock.

Use the designated parts must be connected to a power source.

- Connector manufacturers: PHOENIX CONTACT
PartNo: MVSTBR 2,5 / 2-ST-5, 08 2P 5.00MM

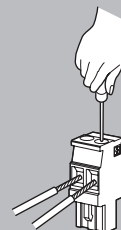

ACP BACNET HARDWARE SPECIFICATION

ACP BACNET HARDWARE SPECIFICATION IS AS FOLLOWS.

Category	Description
Boundary of usage temperature	0 °C ~ 40 °C
CPU	i.MX515 32Bit 800 MHz speed
RAM	<ul style="list-style-type: none"> • PQNFB17C0 : 128MB DDR2 SDRAM * 2EA • PQNFB17C1 : 128MB DDR2 SDRAM * 4EA
ROM	4GB i-NAND Flash
Communication ports	<ul style="list-style-type: none"> • Ethernet 10 / 100 BASE-T • USB : USB Host (SW upgrade, data backup) mini USB Device (Debug) • RS-485 communication ports 6EA • SD card slot (RS-485 communication logging) • RS-232 Console Port (HMI)
External input/output ports	DI, DO
LED	27EA (RS communication status, Ethernet communication status, power status, operation status)
LCD	20 ×4 Character-LCD (network environment setting and information display)



Notes

License policy

This product follows GPL (General Public License) for the use of Embedded Linux.

INSTALLING ACP BACnet

Installing ACP BACnet

This chapter describes how to install the ACP BACnet to use.

In order to use the ACP BACnet, the installation should be performed by the following order.

STEP 1. Check the cautions during the ACP BACnet installation

Before installing the ACP BACnet, check the cautions.

STEP 2. Study the cable connections diagram of the entire system

Study the cable connection diagram of the site where the ACP BACnet is installed.

STEP 3. Set the indoor unit address

Set the address of the ACP BACnet not to be overlapped with the connecting indoor unit.

STEP 4. Set PI485 and connect cables

Set DIP switch of PI485 correctly, and connect RS-485 communication cable.

STEP 5. Install ACP BACnet and connect cables

Install the ACP BACnet, and set network and other settings.

STEP 6. Set ACP BACnet network address

Set the network address to be able to access the ACP BACnet through internet.

STEP 7. Set ACP BACnet functions

Set language, peak/demand, etc.

STEP 8. Set Web GUI access environment

Set the access environment in Web GUI, which is the operation program of the ACP BACnet.

STEP 9. Input indoor unit and ERV information

Set the access environment in Web GUI, which is the operation program of the ACP BACnet.

STEP 10. Verify and check ACP BACnet installation

Verify and check whether the ACP BACnet is properly installed.

**Caution****Installing the ACP BACnet**

- The ACP BACnet installation work needs the professional technique. Therefore, the installation described in this chapter should be performed by the certified installation professional.
- Consult the service center or the professional installation agency certified by us about any question or request related to the installation.

Check points during the ACP BACnet installation

- The number of PI485 connected to one RS-485 communication line
 - ACP BACnet provides 4 RS-485 ports for indoor unit connection. (CH 1~4)
 - Up to 16 PI485 for outdoor unit can be connected to one RS-485 port, and up to 31 PI485 for SINGLE/ERV can be connected.
- The number of the indoor units that can be connected to one ACP BACnet

One ACP BACnet can be connected up to 256 indoor units. With ACS I/O interlocking, you can connect 128 indoor units and 16 I/O modules. And with chiller interlocking, you can connect 128 indoor units and 10 chiller units.

But, to improve the communication performance of RS-485, it is recommended to be divided and connected to 4 ports.

To one RS-485 port, all of 256 indoor units, which is the maximum number that can be connected to the ACP BACnet, may be connected.

The maximum quantity of connected indoor unit is different depending on the quantity of connected I/O modules.

Please refer to following information related to product connection quantity.

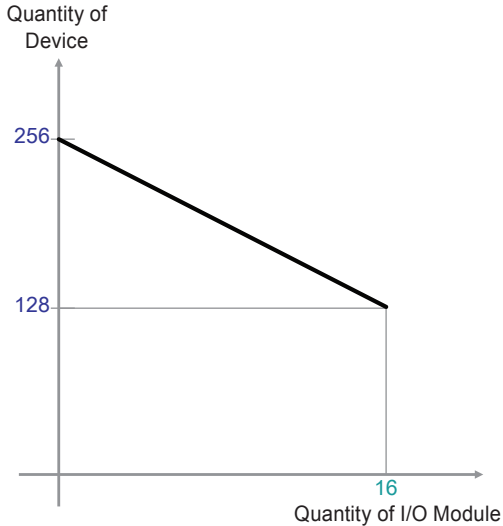

Quantity of I/O Module	Quantity of Device
0	256
1	248
2	240
3	232
4	224
5	216
6	208
7	200
8	192
9	184
10	176
11	168
12	160
13	152
14	144
15	136
16	128

* Devices: Indoor units, ERV, DI/DOs, DOKITs, AWHPs, AHUs

- RS-485 communication cable connection
 - There is a polarity in RS-485 communication cable connection, so be careful not to reverse the connection of the two cables.
 - Do not let the length of RS-485 communication cable exceed total of 1 km.
 - RS-485 communication cable must be connected with BUS type.
- IP address of the ACP BACnet
 - IP address of the ACP BACnet, address of Gateway, and Net mask must be requested to the person in charge of the network of the corresponding site.



Caution

RS-485 Connection of the ERV equipment

To connect ERV equipment, it is recommended to use the ports other than RS-485 communication ports which are connected to air conditioners.

Setting the indoor unit address

By considering the entire installation configuration connecting to one ACP BACnet, set the address to each indoor unit not to be overlapped. 00~FF in hexadecimal can be set to the indoor unit address. However, in case of I/O module, address 00 should not be set because address 00 is used as Broadcast in MODBUS communication.

! Notes

Assigning indoor and outdoor unit number

If the outdoor unit product is Multi V, it is recommended to assign the address by setting the first digit of the address as the number of the outdoor unit, and classifying the second digit as the number or the indoor unit, for easy composition and classification of the system.

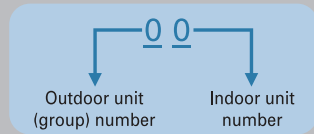

Here is an example of configuring ACP BACnet and the device.

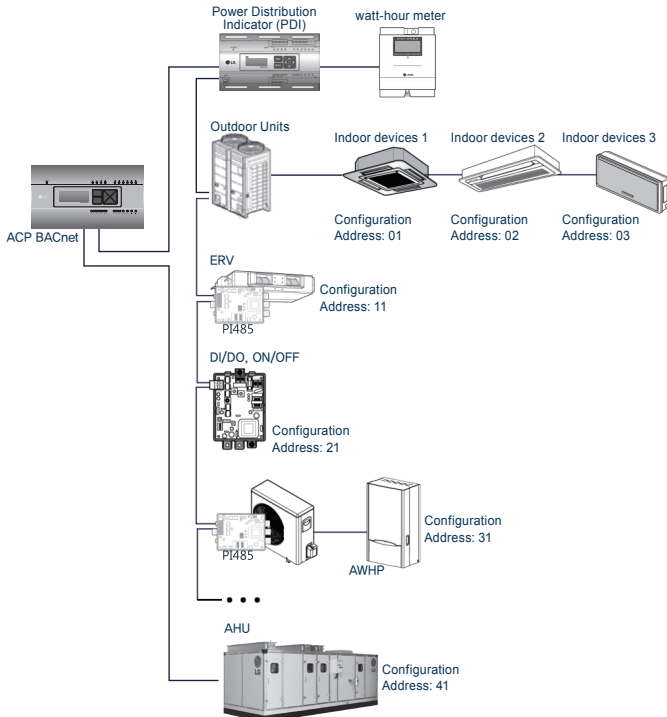

When the ACP BACnet is interconnected with the AC Manager IV, the ERV can be installed together and controlled.

The above figure shows the example that sets the addresses of 30 and 31 to the ERV and connects to the ACP BACnet.



Notes

How to set the central control address of the indoor unit

The central control address setting method may be different for each indoor unit product or remote control type, so set the address by referring to the manual of the indoor unit product or wired remote controller.

Setting the PI485 and connecting the cable

After setting the address of the indoor unit, install the PI485 and set the DIP switch.

And then, connect the RS485 cable for communication with the ACP BACnet.



Notes

Installing the PI485

- Installing the PI485 depends on the outdoor unit.
- So, install the PI485 by referring to the PI485 manual or the installation technique information.

To connect PI485 and the ACP BACnet, two RS-485 cables need to be connected to BUS-A and BUS-B of PI485. Connect RS-485 cable by referring to the following figure.

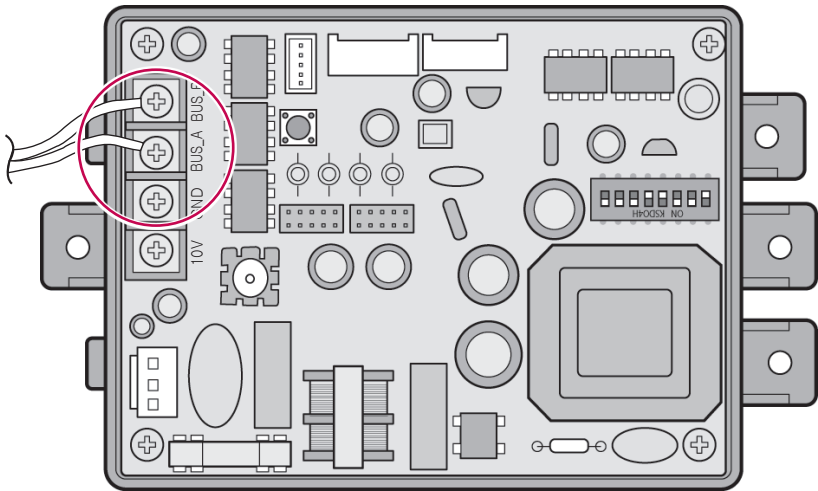

If several PI485 are connected to each other to be connected to one ACP BACnet, connect each BUS-A and BUS-B of PI485 to be connected to BUS-A and BUS-B of another PI485.

The following figure is an example of connecting several PI485 with each other to connect to one ACP BACnet.

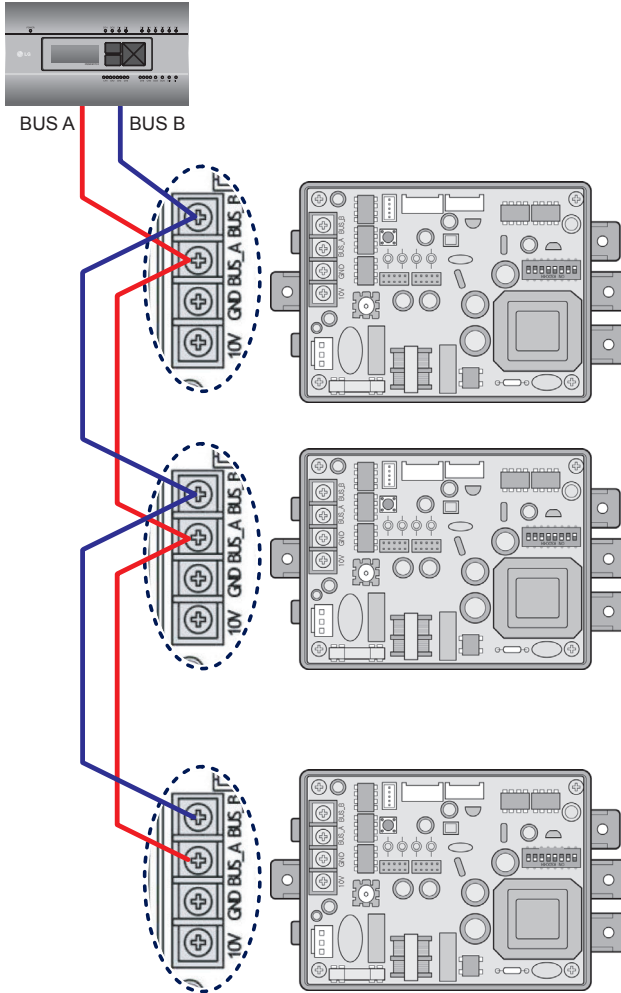

Installing ACP BACnet and connecting cables

After setting PI485, the ACP BACnet shall be installed in an adequate place, and RS-485 cable shall be connected for the communication with PI485.

And, Ethernet cable (LAN cable) shall be connected for the connection with internet or AC Manager IV. To fix the ACP BACnet, the following 2 methods may be used.

Install in DIN RAIL or fix to the wall considering the environment of the site.

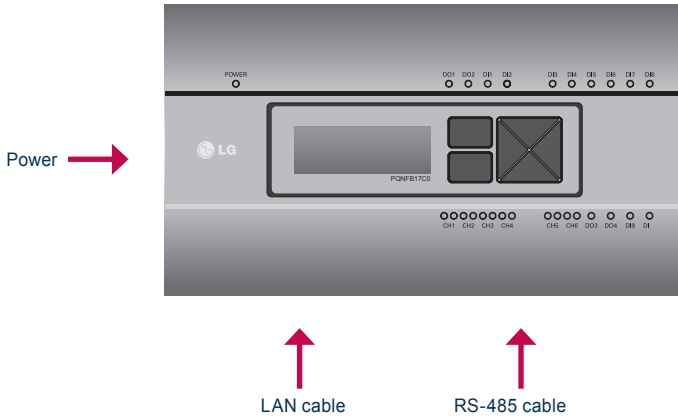

Installing the ACP BACnet in DIN RAIL

ACP BACnet can be installed in DIN RAIL with width 35 mm and height 7.5 mm.

Proceed as the follows to install the ACP BACnet in an adequate place.

The installation method of the ACP BACnet is explained here with the example of installing the ACP BACnet in DIN RAIL.

- Decide the space to install the ACP BACnet.
- Before installing the ACP BACnet, check if it is the adequate place to connect the ACP BACnet with the power, RS-485, and LAN cable.
- Install DIN RAIL.
- Hook the top part of the ACP BACnet on DIN RAIL.
- Push the main body of the ACP BACnet until you hear the sound of installation.
- Pull the ACP BACnet to check if it is fixed.

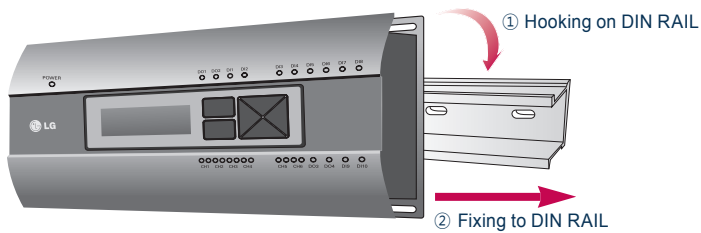

Caution

- After installing to DIN RAIL, do not fix to the wall using screws.
- ACP BACnet may be damaged.
- DIN Rail fixing Screw Spec: M3, screw head height 2.0 ~ 1.75 mm, screw head diameter 7.0 ~ 5.5 mm

Fixing the ACP BACnet to the wall

ACP BACnet can be installed by fixing to the wall. To install the ACP BACnet in an adequate place, proceed according to the following explanation. It explains here on how to install the ACP BACnet with the example of installing the ACP BACnet on the wall.

- Decide the space to install the ACP BACnet. Before installing the ACP BACnet, check if it is the adequate place to connect the ACP BACnet with the power, RS-485, and LAN cable.
- Fix to the wall using the driver. It can be fixed as in the following figure according to the location to install.

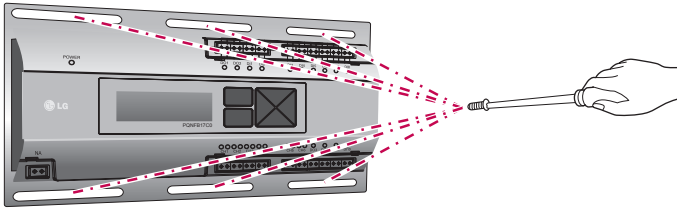

Connecting RS-485 cable to the ACP BACnet

After fixing the ACP BACnet in the installation place, RS-485 cable that was connected to PI485 shall be connected to the ACP BACnet. To connect RS-485 cable to the ACP BACnet, proceed as the following order.

- First, among the connectors that can be connected to the ACP BACnet, connect the end of RS-485 cable connected to BUS-A of PI485 to Tx part. Next, connect the end of RS-485 cable connected to BUS-B of PI485 to Rx part.
- RS-485 cable that was connected to PI485 shall be connected to CH port (RS-485 port) of the ACP BACnet.
 - Plug the connector connecting RS-485 cable into one of CH1 ~ CH4 ports.
 - There are 1~6 CH ports, and it must be plugged into one of 1~4 ports for use.
 - For AHU, plug the connector connecting RS-485 cable into CH5 ports.

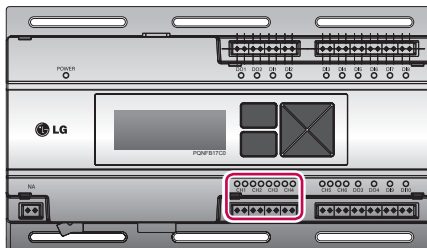

Information: Connecting RS-485 of the ACP BACnet

Up to 16 outdoor units can be connected to one RS-485 port of the ACP BACnet, and up to 256 indoor units can be connected to one ACP BACnet. If there are many outdoor units to connect, the outdoor unit connections shall be appropriately connected to CH1 to CH4 in BUS format. Otherwise, the ACP BACnet may malfunction.

The following is an example of dividing to CH1 and CH2 and connecting in BUS format.

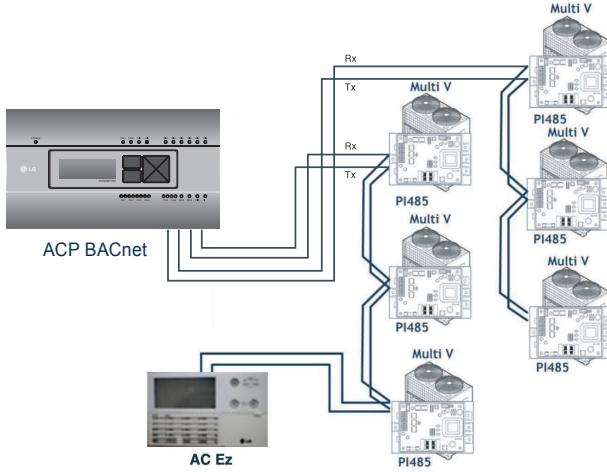

The next shows the wrong example (STAR connection) of RS-485 connection of the ACP BACnet.

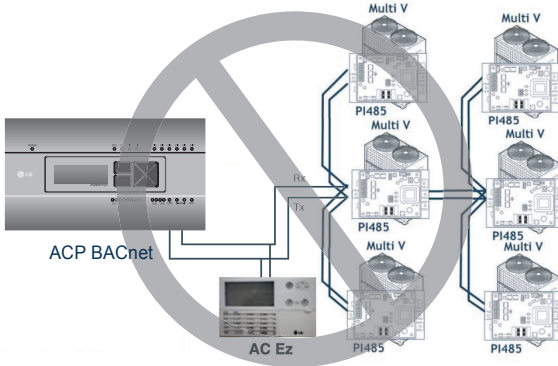

**Caution**

If a different type of connection is made other than BUS format as in the figure, the product may malfunction. So be careful during the installation.

Connecting Ethernet cable (LAN cable) to the ACP BACnet

After connecting the ACP BACnet and RS-485 cable, Ethernet cable shall be connected to the ACP BACnet.

ACP BACnet may be connected to hub through Ethernet cable, or directly to AC Manager IV.

Connecting the ACP BACnet and hub

It is the case of connecting the ACP BACnet to the basic internet network installed at the site, and it is generally connected to the hub.

In such case, Ethernet cable shall be connected as a direct cable.

Use Ethernet cable (direct cable) to connect to LAN port of the ACP BACnet.

Connecting ACP BACnet and PC

It is the case of installing AC Manager IV in a separate PC and connecting ACP BACnet and PC directly.

In such case, Ethernet cable shall be connected as a cross cable.

Use Ethernet cable (cross cable) to connect to LAN port of the ACP BACnet.

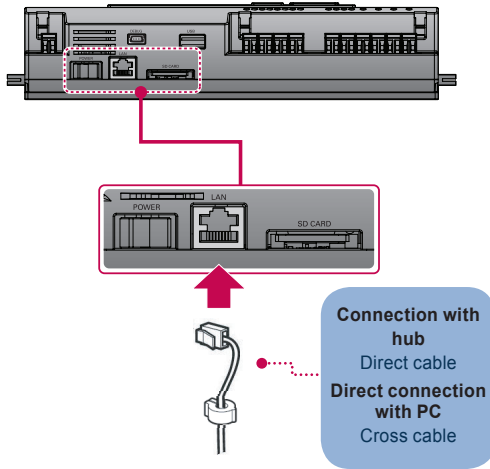

Caution

Ethernet cable types

- You must distinguish if the Ethernet cable to connect is a direct cable or a cross cable.
- Also, connect after checking the existence of problem in the cable using LAN tester.

Setting the ACP BACnet network address

After connecting the ACP BACnet to various devices via the cable, the network environment of the ACP BACnet should be set by driving the ACP BACnet. The following information should be set for using the ACP BACnet.

- IP address of the ACP BACnet
- Gateway address
- Net mask



Caution

Setting the network environment information

If the above information is not entered, the communication error may be occurred or it may be impossible to control by the ACP BACnet. So, be careful to correctly input.

Before configuring the ACP BACnet environment

The network environment of the ACP BACnet can be set by the LCD and the buttons at the front side of the ACP BACnet.

The current ACP BACnet information and the menu are displayed on the LCD, and the menu can be changed and selected by pressing **SET** and **↩** button and Up/Down/Left/Right (▲, ▼, ◀, ▶) buttons.

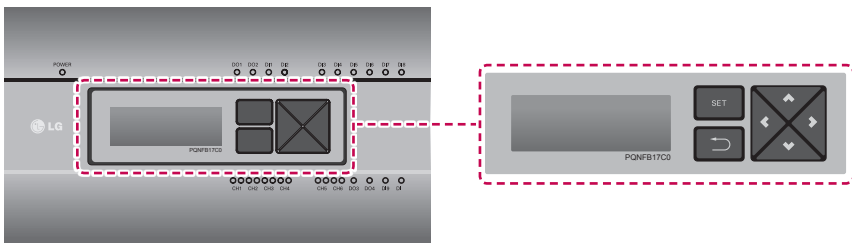

Turning on the ACP BACnet

Turn on the ACP BACnet to set the network environment of the ACP BACnet.

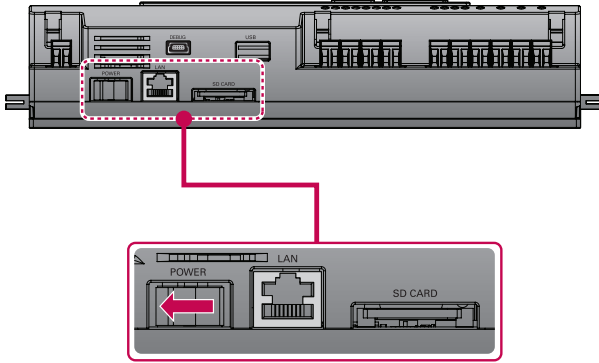

When the power switch is turned on, the ACP BACnet booting screen is displayed on the LCD as shown at the following figure, and when booting is completed, the initial ACP BACnet screen is displayed.

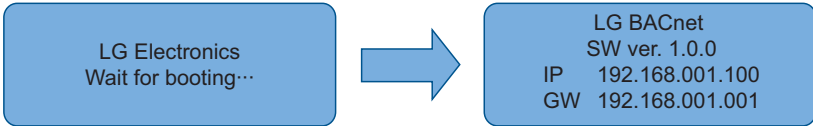

! Notes

RAM capacity

The ACP BACnet with 256 MB RAM is displayed as LG BACnet at the initial ACP BACnet screen. The ACP BACnet with 512 MB RAM is displayed as LG BACnet-R at the initial ACP BACnet screen. Also, RAM capacity may be different according to the manufacturing date of the ACP BACnet.

LG BACnet-R
SW ver. 1.0.0
IP 192.168.001.100
GW 192.168.001.001

! Notes

Software version

The software version of the current ACP BACnet is displayed at the initial ACP BACnet screen. Also, the software version may be different according to the manufacturing date of the ACP BACnet.

LG BACnet
SW ver. 1.0.0
IP 192.168.001.100
GW 192.168.001.001

Entering into the environment setup mode

Press **[SET]** button of the ACP BACnet to enter into the environment setup mode of the ACP BACnet.

When the **[SET]** button is pressed for the first time, the menu to set the IP address is displayed as shown below.

```
> Network Info
  Contents
  Function
  Register FD
```

Press up/down(▲, ▼) button to place the arrow on the desired function.

- When you select **[Network Info]** and press **[SET]** button, it enters the No. 1 menu in the following figure.
- In **[Network Info]** menu, input the network information such as IP address of the ACP BACnet.
- When you select **[Contents]** and press **[SET]** button, it enters the No. 2 menu in the following figure.
- In **[Contents]** menu, you can set the functions of the ACP BACnet and select language to use.
- When you select **[Function]** and press **[SET]** button, it enters the No. 3 menu in the following figure.
- In **[Function]** menu, ACP BACnet software service function is supported.
- When you select **[Register FD]** and press **[SET]** button, it enters the No. 4 menu in the following figure.

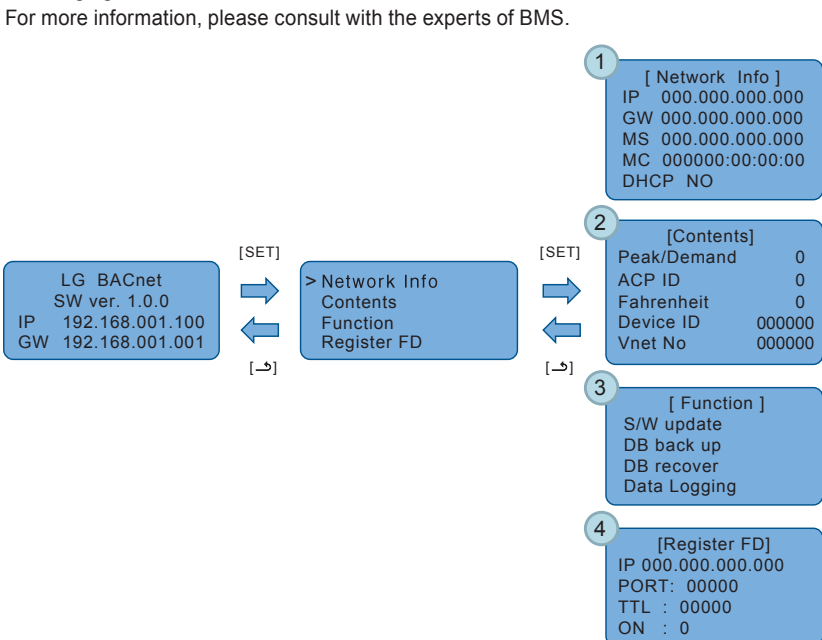



Caution

- **[Function]** menu is used by the system air conditioner service technician, so user shall never use this function.
- If this function is incorrectly used, it may cause disorder of the ACP BACnet.

How to set network address

In **[Network Info]** menu, use the category to set using “up” and “down” (▲, ▼) buttons.

IP, Gateway, and Net mask settings are displayed in the initial screen of **[Network Info]** menu, and you can check MAC address and DHCP setting using “down” (▼) button.

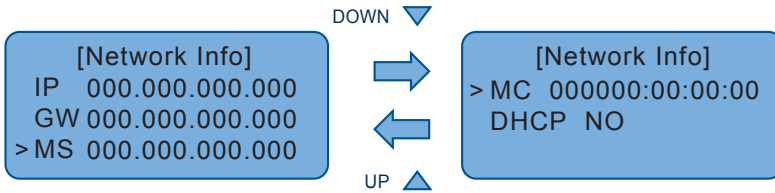

To change the network setting, locate the arrow on the corresponding setting position, and press **[SET]** button to enter the corresponding setting screen.

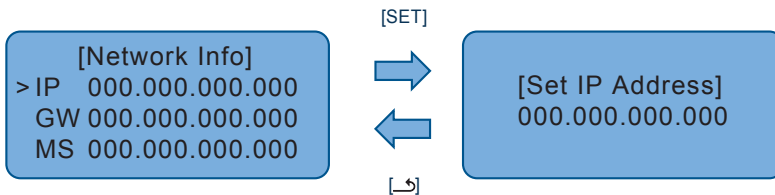

The network address consists of four 3-digit numbers. In case of setting the network address, the name of the related address is displayed on the LCD of the ACP BACnet, and press Up/Down/Left/Right (▲, ▼, ◀, ▶) button to set.

Press Up/Down (▲, ▼) button to increase/decrease the number of the digit where the cursor is on, and press Left/Right (◀, ▶) button to move the digit of the network address to the left or right.

Example of pressing down (▼) button

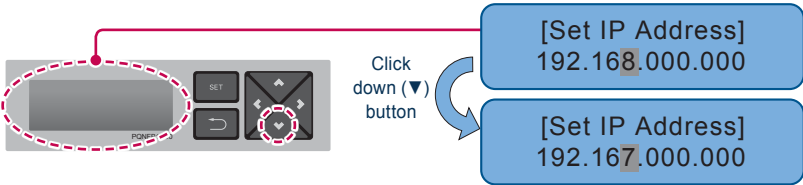

Example of pressing right (▶) button

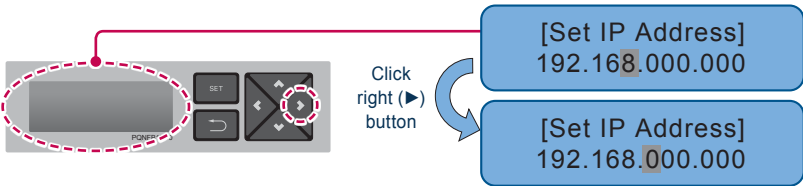

Caution

Setting the network address

- The network address can be separated to 4 digits based on ., and each number shall be 255 or less.
- Number exceeding 255 may not be input.



Notes

Assigning the network address

- Network address shall be assigned by the person in charge of the network of the corresponding site. (IP address, Gateway address, Net mask)
- ACP BACnet can use both fixed IP type and dynamic IP type, but fixed IP type is recommended, and if dynamic IP type is used, it may cause inconvenience of the customer.
- Please refer to "Using dynamic IP using DHCP" for details.
- If fixed IP type is used, network address (IP address, Gateway address, and Net mask) shall be assigned by the person in charge of the network of the corresponding site.

Setting IP address

For user to use the functions of the ACP BACnet through the web, a unique IP address may be assigned to the ACP BACnet or dynamic IP setting may be used. The next is how to set fixed IP address.

Please proceed according to the order.

1. Press **[SET]** button of the ACP BACnet. The following menu screen will be displayed.
 - If you press **[SET]** button again, **[Network Info]** setting screen will be displayed.
 - While IP is selected, pressing **[SET]** button will display the screen to input IP address.

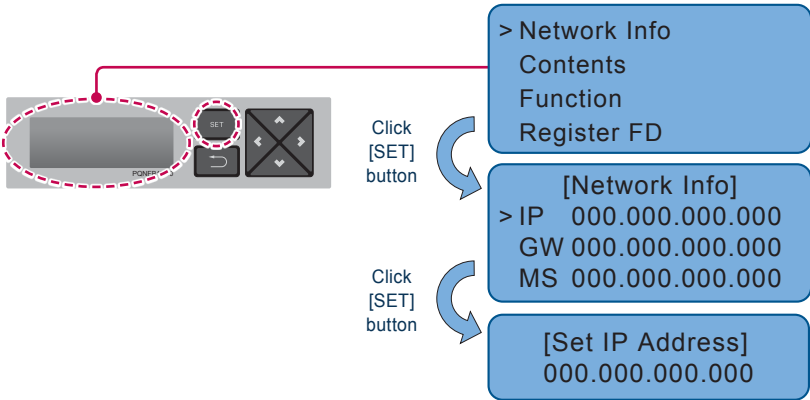

2. Use up, down, left, right (**▲**, **▼**, **◀**, **▶**) buttons to input the desired IP address.



Using dynamic IP using DHCP

For user to use the functions of the ACP BACnet through the web, a unique IP address may be assigned to the ACP BACnet or dynamic IP setting may be used.

The next is how to set dynamic IP address.

Please proceed according to the order.

1. Press **[SET]** button of the ACP BACnet. The following menu screen will be displayed.
 - If you press **[SET]** button again, **[Network Info]** setting screen will be displayed.
 - While DHCP is selected, if you press **[SET]** button, you can input whether to use DHCP function.

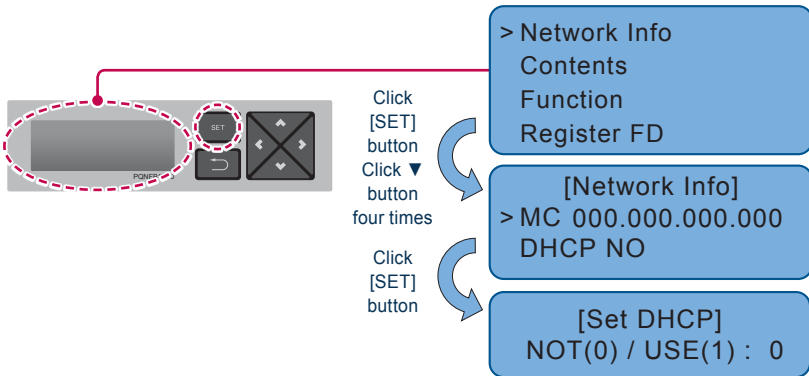

2. Use up and down (▲, ▼) buttons to set whether to use DHCP function.
 - When you press up (▲) button, DHCP function is set to use, and if down (▼) button is pressed, DHCP is set for no-use.
3. To use dynamic IP, set to use DHCP function.

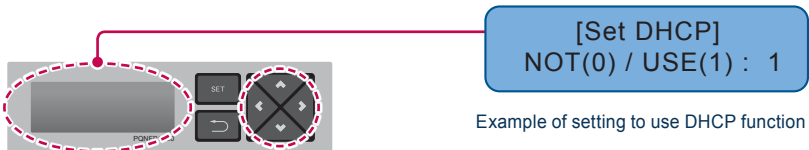

Caution

- If dynamic IP type is used, the IP in use is returned by DHCP server and may not be able to access the ACP BACnet. In such case, you can check the newly set IP address in the front LCD of the ACP BACnet.
- If you input the ACP BACnet IP address in the web browser, you can run the ACP BACnet program again.

Checking ACP BACnet access

It checks whether the ACP BACnet network address setting is properly done.

You can check the possibility of accessing the ACP BACnet through PING test.

1. You can open the following DOS window through Windows "Start", "Run", "cmd" input.

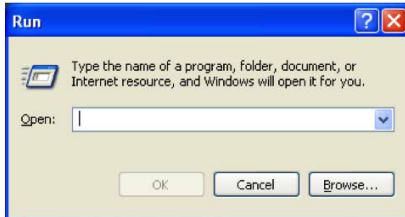

2. In DOS screen, input "ping <ACP BACnet IP address>" as follows to run PING test.

```

C:\WINDOWS\system32\cmd.exe
(C) Copyright 1985-2001 Microsoft Corp.

C:\Documents and Settings\Administrator>ping 165.186.32.174

Pinging 165.186.32.174 with 32 bytes of data:

Reply from 165.186.32.174: bytes=32 time<1ms TTL=63
Reply from 165.186.32.174: bytes=32 time<1ms TTL=63
Reply from 165.186.32.174: bytes=32 time<1ms TTL=63
Reply from 165.186.32.174: bytes=32 time<1ms TTL=63

Ping statistics for 165.186.32.174:
    Packets: Sent = 4, Received = 4, Lost = 0 (0% loss),
    Approximate round trip times in milli-seconds:
        Minimum = 0ms, Maximum = 0ms, Average = 0ms

C:\Documents and Settings\Administrator>

```

When the network setting is properly done

```

C:\WINDOWS\system32\cmd.exe
Microsoft Windows XP [Version 5.1.2600]
(C) Copyright 1985-2001 Microsoft Corp.

C:\Documents and Settings\Administrator>ping 165.186.32.242

Pinging 165.186.32.242 with 32 bytes of data:

Request timed out.
Request timed out.
Request timed out.
Request timed out.

Ping statistics for 165.186.32.242:
    Packets: Sent = 4, Received = 0, Lost = 4 (100% loss),

C:\Documents and Settings\Administrator>

```

When the network setting is not properly done



Notes

When you connected the ACP BACnet and PC through a cross cable, but you cannot access the ACP BACnet

- Check IP address of the ACP BACnet and IP address of the PC.
Ex) If IP address of the ACP BACnet is 192.168.1.101 and Net mask is 255.255.255.0, check if the first three digits of the IP address of the PC is the same as the first three digits of the IP address of the ACP BACnet.
In such case, the IP address of the PC shall start with 192.168.1, and it shall be different from the IP address of the ACP BACnet. Set as follows, and try again.
 - Setting of the ACP BACnet
 - IP address: 192.168.1.112
 - Gateway address: 192.168.1.1
 - Subnet Mask: 255.255.255.0
 - Setting of the PC
 - IP address: 192.168.1.113
 - Gateway address: 192.168.1.1
 - Subnet Mask: 255.255.255.0
- Check the status of the Ethernet cable (LAN cable).

When PC and ACP BACnet are connected together in a hub or a switch hub, and you cannot access the ACP BACnet.

- If it is right after changing the IP setting of the ACP BACnet, reset the power of the ACP BACnet.
- If it is right after connecting LAN cable to the hub or switch, it may take time for the hub or the switch to recognize the ACP BACnet. In such case, it may help to turn off and turn on the power of the hub or the switch.
- Check the status of the Ethernet cable (LAN cable).
- Check ARP table of the PC to see if the IP address of the ACP BACnet correctly corresponds to the MAC address. If duplicate MAC addresses correspond to one IP address, or if different address from the MAC address of the PC is output, there may be a host with the same IP address as the IP address of the ACP BACnet. In such case, the IP address of the ACP BACnet or the IP address of the corresponding host shall be changed.

```

ex C:\WINDOWS\system32\cmd.exe

C:\Documents and Settings\Administrator>arp -a

Interface: 165.186.2.251 --- 0x2
  Internet Address      Physical Address      Type
  10.16.76.148          00-03-2e-05-08-b3    dynamic
  165.186.2.129        00-13-c3-86-67-ff    dynamic
  192.168.1.150         00-00-00-00-00-00    invalid
  
```

How to check ARP table

Setting the functions of the ACP BACnet

The following functions can be set by using the menu of the ACP BACnet:

- Select Peak or Demand
- Fahrenheit/Celsius setting function
- Device ID setting function
- Vnet number setting function
- Foreign Device register function

Selecting Peak or Demand

The ACP BACnet offers the function to manage the power consumed by the connected air conditioner, by which the electric charges can be effectively saved. The ACP BACnet offers two functions to limit the maximum power consumption of the air conditioner as follows:

- **Peak:** The maximum power consumption of the air conditioner can be managed by setting the maximum usage operation ratio in the ACP BACnet.
- **Demand:** Not used.

One of these two methods can be selected and used in the ACP BACnet. And, if it is set by the menu of the ACP BACnet, the UI screen is differently displayed when accessing the web screen to set the function. The ACP BACnet should be set to the Demand function for the following cases:



Notes

Default value

The default value at factory ship-out is set to Peak.

Change the power control method as follows:

1. When you press **[SET]** button, menu screen will be displayed. Use up and down (**▲**, **▼**) buttons of the ACP BACnet to select **[Contents]**, and press **[SET]** button again. While **[Peak/Demand]** is selected, pressing **[SET]** button will display the screen to select peak or demand method.

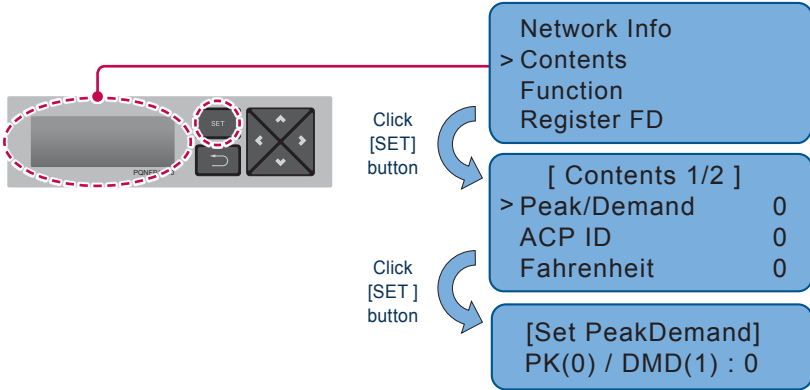

2. Use up and down (**▲**, **▼**) buttons to set the desired power management method. If you press up (**▲**) button, it is set to demand method, and if you press down (**▼**) button, it is set to peak method.



Remote Shutdown function

ACP BACnet provides Remote Shutdown function.

After connecting the emergency sensor to ACP BACnet DI1, if the emergency sensor detects emergency, it stops the operations of all connected equipments except the Chiller.



Caution

Remote Shutdown interface

- To use the Remote Shutdown function, emergency sensor needs to be connected to ACP BACnet DI1.
- Please refer to each emergency sensor product manual for detail usage of emergency sensors.

Setting Celsius/Fahrenheit

ACP BACnet provides Celsius/Fahrenheit setting function.

To send the Celsius temperature to the BMS, set **[Fahrenheit]** to 0. To send the Fahrenheit temperature to the BMS, set **[Fahrenheit]** to 1. Proceed in the following order.

1. When you press **[SET]** button, menu screen will be displayed. Use up and down (**▲**, **▼**) buttons of the ACP BACnet to select **[Contents]**, and press **[SET]** button again. While **[Fahrenheit]** is selected, pressing **[SET]** button will display the screen to select Celsius or Fahrenheit.

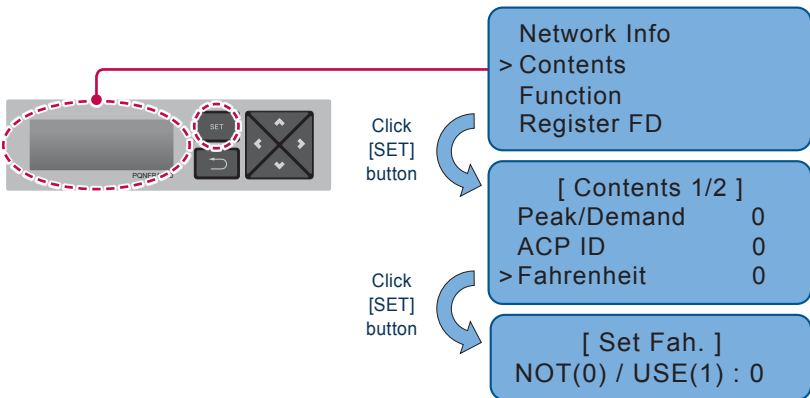

Setting Device ID

To designate the Device Instance Number of ACP BACnet, Device ID must be set.

Default Device ID is 9000, Device Instance Number is designated as below.

- Indoor unit : Device ID
- ERV : Device ID + 1
- AHU : Device ID + 2
- Outdoor unit cycle information : Device ID + 3
- AWHP : Device ID + 4

Proceed in the following order.

1. When you press **[SET]** button, menu screen will be displayed. Use up and down (**▲**, **▼**) buttons of the ACP BACnet to select **[Contents]**, and press **[SET]** button again. While **[Device ID]** is selected, pressing **[SET]** button will display the screen to select Device ID.

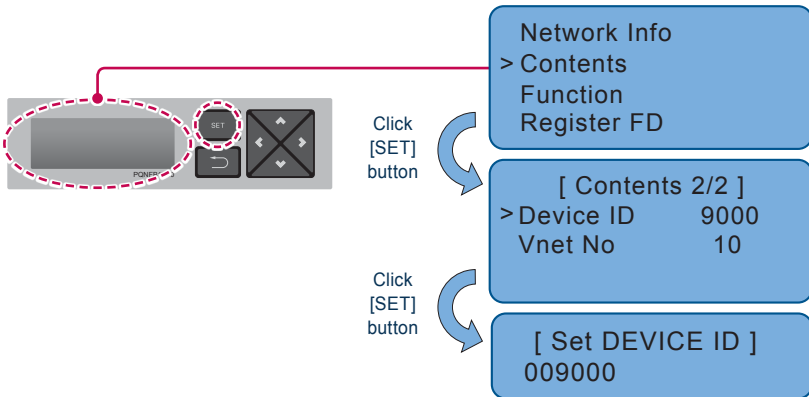

Setting Vnet Number

To use Modbus TCP function of ACP BACnet, Vnet Number must be set.

Set Vnet Number is used to Slave ID Address of Modbus TCP.

Proceed in the following order.

1. When you press **[SET]** button, menu screen will be displayed. Use up and down (**▲**, **▼**) buttons of the ACP BACnet to select **[Contents]**, and press **[SET]** button again. While **[Vnet No]** is selected, pressing **[SET]** button will display the screen to set Vnet Number.

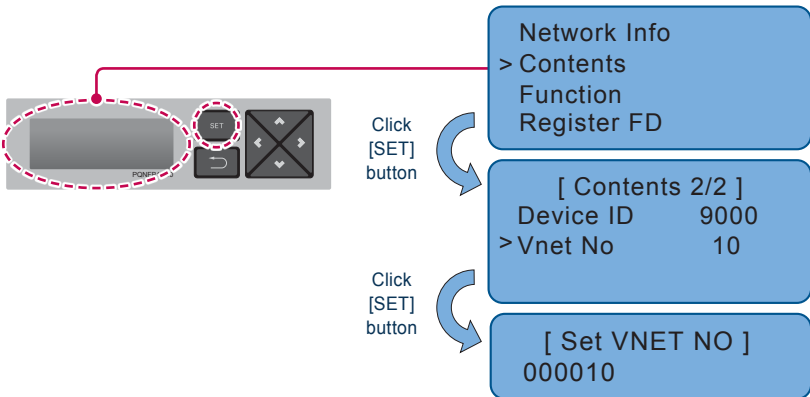

Software service function

The following software service function can be run using the menu of the ACP BACnet.

This function shall only be used by the specialized service technician, and negligent use may cause failure of the ACP BACnet system.

- Software update
- Data backup
- Data recovery
- RS-485 data logging

Software update

When it is necessary to update the ACP BACnet software, it must be carried out by the specialized service technician.

Software update can be done with USB memory.

Proceed in the following order.

1. Create "ramdisk" folder in USB memory.
2. Put the S/W file to update in 'ramdisk' folder.
 - At this time, only one S/W file must be put.
(New version software file can be downloaded from LG Electronics System Air Conditioner homepage.)

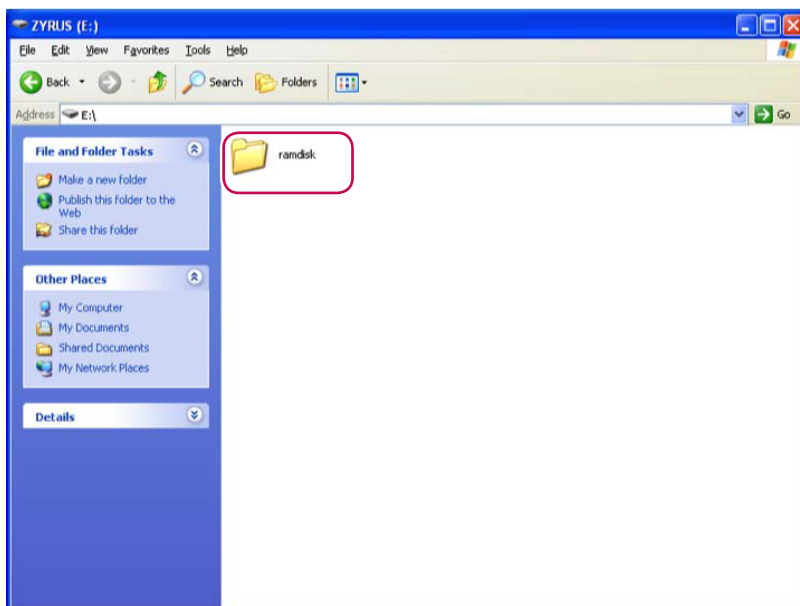

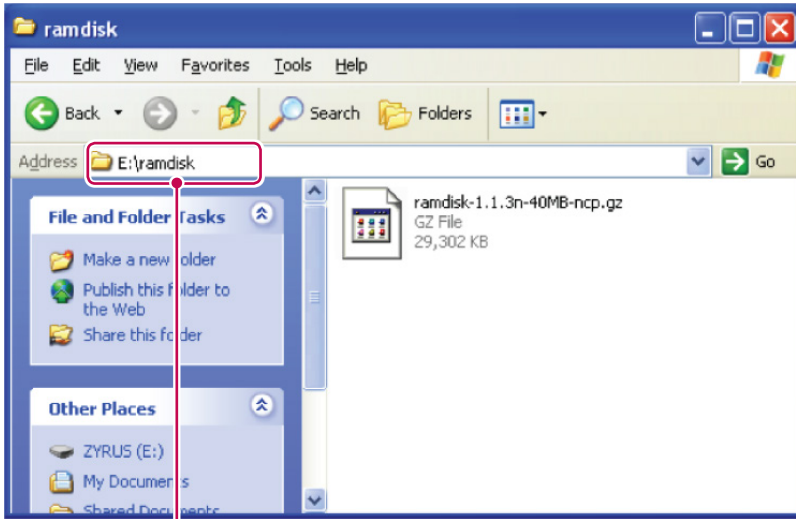

E: may be changed.

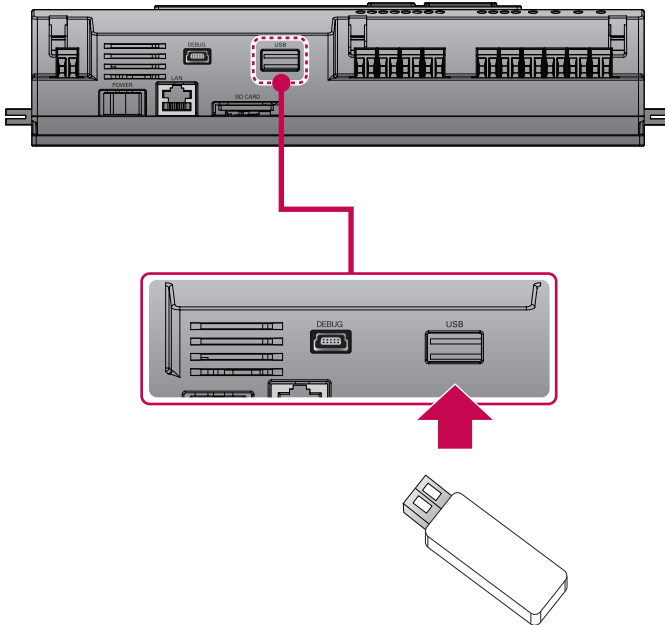

1. Press **[SET]** button of the ACP BACnet.
2. Select **[Function]** menu, and press **[SET]** button.
3. Select **[S/W update]** menu, and press **[SET]** button again.
4. To run the software update, press **[SET]** button again.
 - Wait while software is running.
5. After completing the update, press **[SET]** button to restart the ACP BACnet.
 - Even when you do not immediately restart, update will be applied only after rebooting the ACP BACnet in the future.

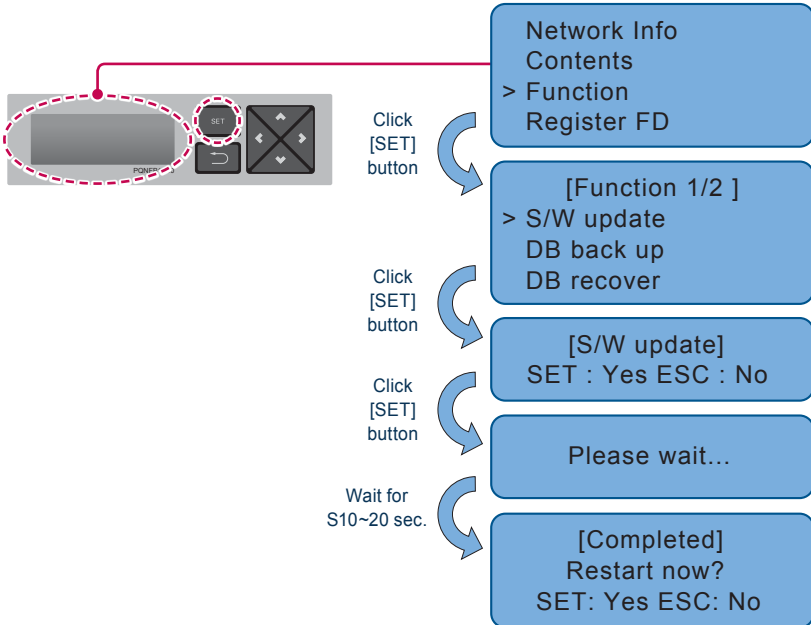

Caution

While software update is in progress and while "Please wait..." is displayed, turning off the power of the ACP BACnet or removing USB memory may cause severe disorder of the ACP BACnet.

Data backup

If ACP BACnet data backup is necessary, it must be carried out by the specialized service technician.

Data backup can be done with USB memory or SD card.

Proceed in the following order.

1. Insert USB memory or SD card into the ACP BACnet.
(Refer to software update for USB memory insertion.)

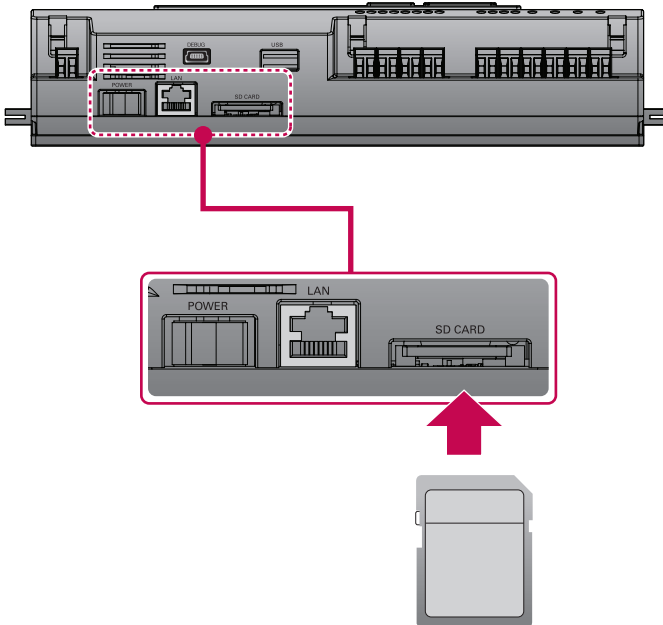

2. Press **[SET]** button of the ACP BACnet.
3. Select **[Function]** menu, and press **[SET]** button.
4. Select **[DB back up]** menu, and press **[SET]** button again.
5. Select **[USB]** or **[SD card]**, and press **[SET]** button.
6. After completing backup, remove USB memory.

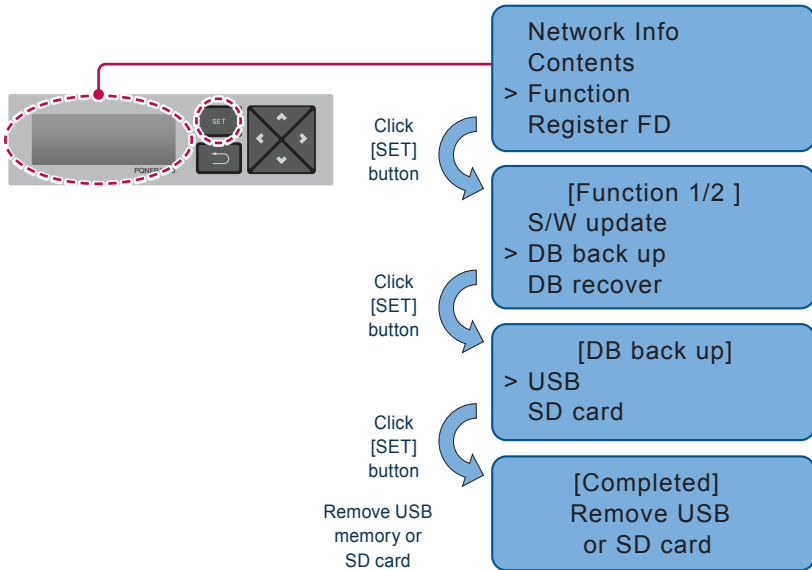

Caution

Before data backup is completed, turning off the power of the ACP BACnet or removing USB memory or SD card may cause severe disorder of the ACP BACnet.

Data recovery

If ACP BACnet data recovery is necessary, it must be carried out by the specialized service technician.

Data recovery can be done with USB memory or SD card.

Proceed in the following order.

1. Save the database file to recover in USB memory or SD card.
 - Save the files in “db” folder as follows.

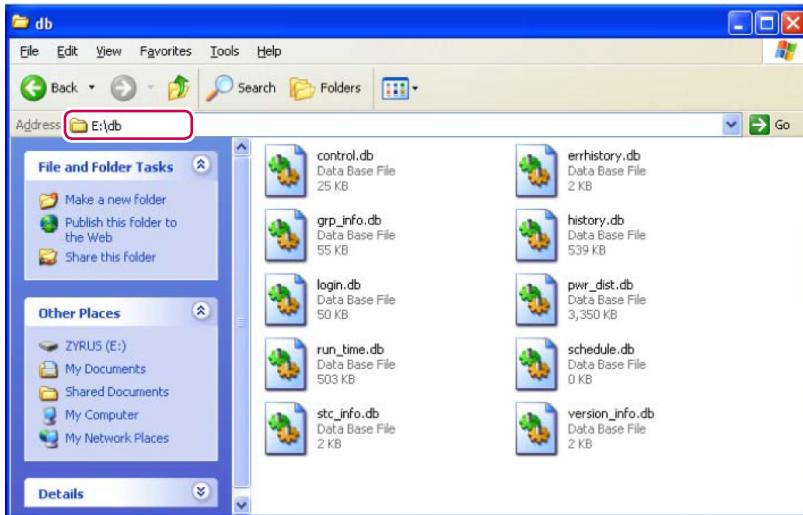

2. Insert USB memory or SD card into the ACP BACnet. (Refer to software update and data backup)
3. Press **[SET]** button of the ACP BACnet.
4. Select **[Function]** menu, and press **[SET]** button.
5. Select **[DB recover]** menu, and press **[SET]** button again.
6. Select **[USB]** or **[SD card]**, and press **[SET]** button.
7. Remove USB memory after completing the data recovery.
 - ACP BACnet is automatically restarted for data recovery.

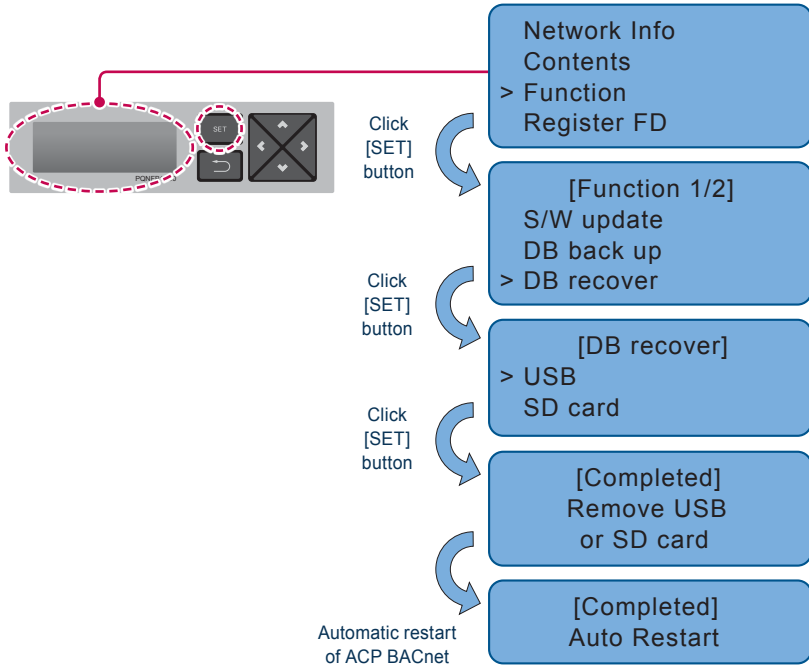

Caution

Before data recovery is completed, turning off the power of the ACP BACnet or removing USB memory or SD card may cause severe disorder of the ACP BACnet.

RS-485 data logging

If ACP BACnet RS-485 data logging is necessary, it must be carried out by the specialized service technician.

Data logging can be done with SD card.

Proceed in the following order.

1. Insert SD card into the ACP BACnet. (Refer to data backup)
2. Press **[SET]** button of the ACP BACnet.
3. Select **[Function]** menu, and press **[SET]** button.
4. Select **[Data Logging]** menu, and press **[SET]** button again.
5. Select whether to set data logging.

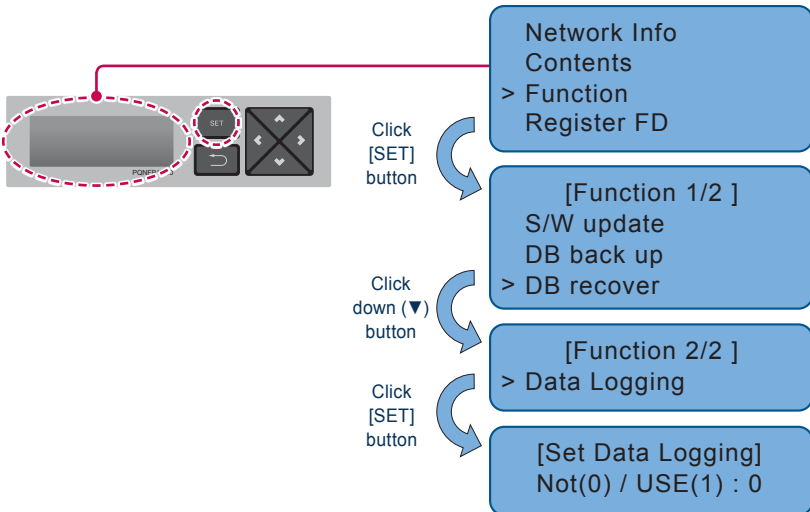

Register Foreign Device

1. In **[Register FD]** menu, use the category to set using “up” and “down” (▲, ▼) buttons.
2. IP, PORT, TTL, and Activate of Foreign Device are displayed in the initial screen of **[Register FD]** menu, and you can check IP, PORT, TTL, and Activate of Foreign Device using “down” (▼) button.
3. To change the Foreign Device setting, locate the arrow on the corresponding setting position, and press **[SET]** button to enter the corresponding setting screen.

Example of IP setting

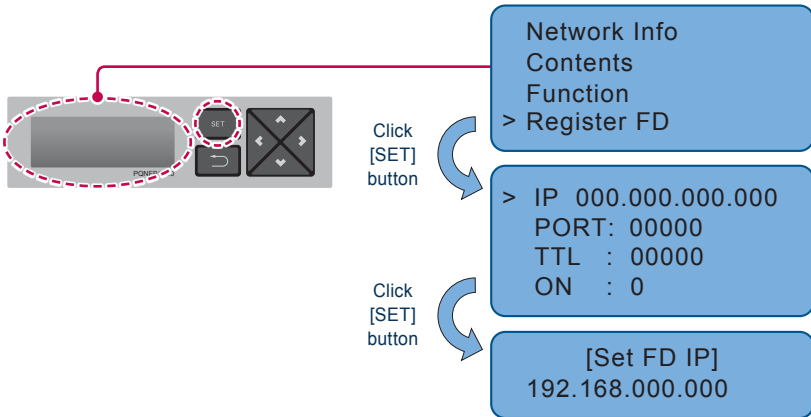

Example of PORT setting

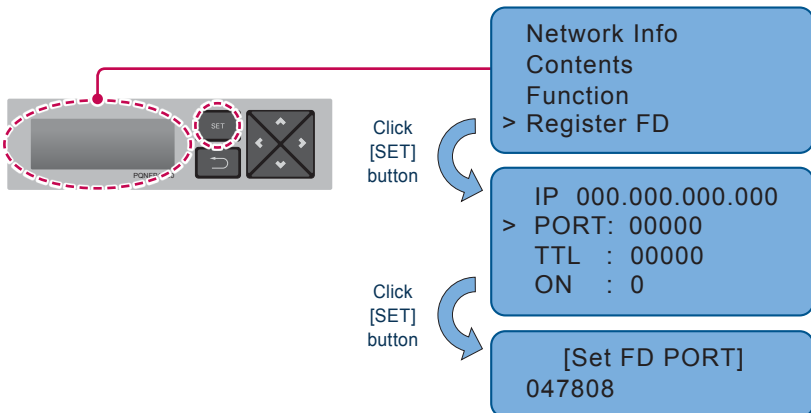

Example of TTL setting

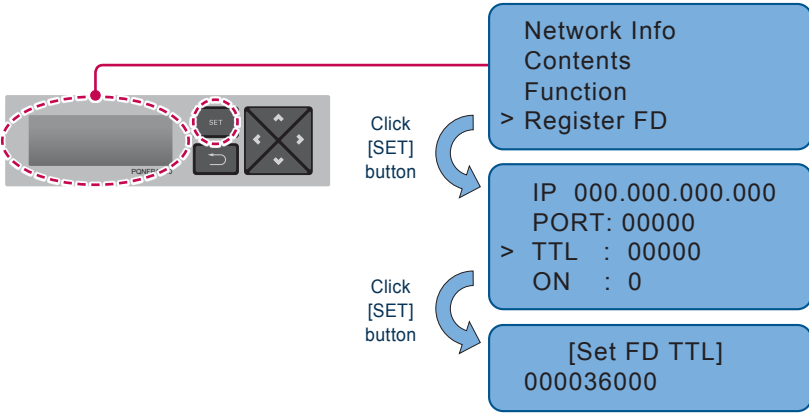

Example of Foreign Device Activate setting

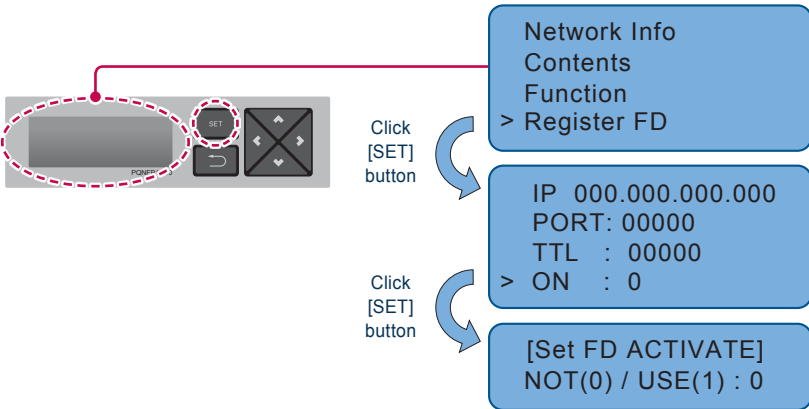

Notes

For more information, please consult with the experts of BMS.

LG'S ACP BACnet AGREEMENT

JMT (Joint Matching Test)

This is necessary for every independent BMS.

The case where a JMT is not necessary is where previously a successful JMT has been carried out and the BMS system has not been updated by software or hardware changes. In the case that the BMS has updated their system by either changes, a following JMT will be required.

ACP BACnet Diagnosis

Use of LG's ACP BACnet setup-tool is for confirming the operation/state of connected A/C units & address ID's, prior to connection with the BMS system.

BMS Engineering

Creating of the Points. This is NOT to be done by LG since it is directly related to the BMS side. The BMS engineer is to carry out the engineering of the Point, however LG is responsible for providing the method of how the Points are calculated.

Commission

First step, only using LG's ACP BACnet, without connecting BMS. This is to be carried out by LG engineering staff with the use of the ACP BACnet set up tool.

Discrepancy of operation of Gateway by BMS

In the case that the BMS maker feels that the ACP BACnet is not functioning correctly via the BACnet Protocol, a test with the use of LG's ACP BACnet Client software can confirm this. (This test is generally not required)

! Notes

After the LG's ACP BACnet agreement part, please consult with the experts of BMS.

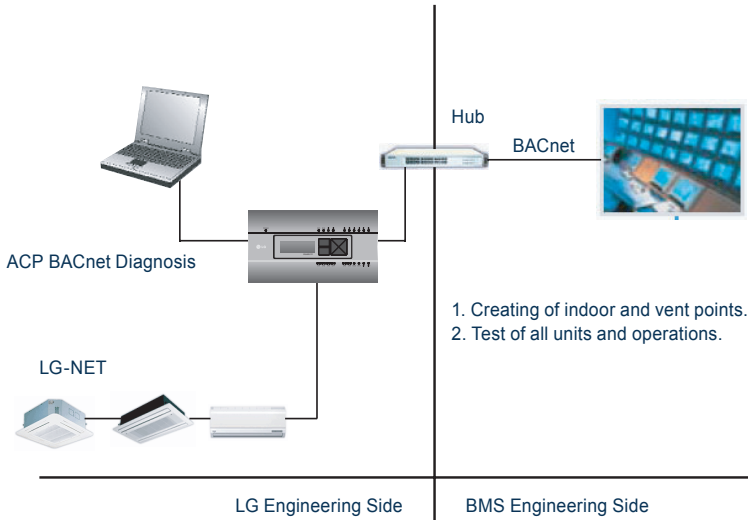

FUNCTIONAL SPECIFICATIONS ACP BACnet

Summary

The ACP BACnet, in response to the requests from the BMS (Building management system which supports BACnet-ANSI/ASHRAE135 protocol), status information of A/C/vent that are connected to the ACP BACnet's internal LG-NET will be sent in BACnet service form, and BACnet client provides a function that transmits control command to the A/C/vent system.

Configuration of Connection

A BACnet client that supports BACnet-ANSI/ASHRAE135 protocol allows direct connection via generally used HUBS or Ethernet. The image of its connection configuration is as shown below.

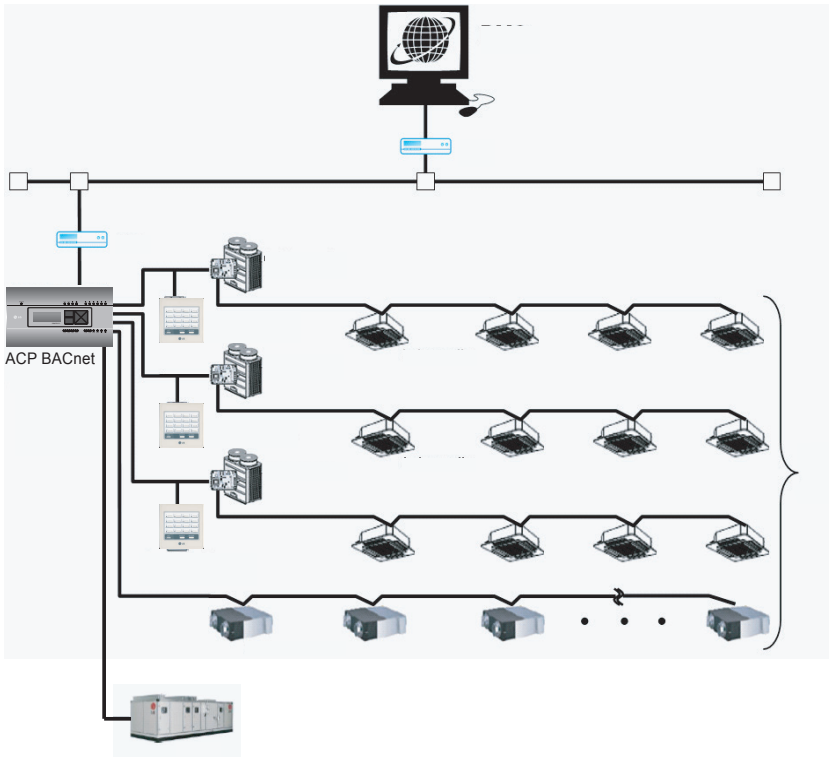

Objects - ACP BACnet/IP

ACP-BAC Point List : Indoor Unit

One indoor unit has a Point List as follows.

Some of IDU Points may not be supported depending on the product.

Point No.	Control/monitoring	Object Name (XXX : Unit address)	Object Type	Unit		Active				
				Inactive Text-0	Text-1	Text-2	Text-3	Text-4	Text-5	
1	ON/OFF (Setting)	StartStopCommand_XXX	BO	Stop	Start					
2	ON/OFF (Status)	StartStopStatus_XXX	BI	Stop	Run					
3	Lock (Setting)	LockCommand_XXX	BO	Permit	Prohibit					
4	Lock (Status)	LockStatus_XXX	BI	Permit	Prohibit					
5	Filter Sign	FilterSign_XXX	BI	Off	On					
6	Filter Sign Reset	FilterSignReset_XXX	BV	-	Reset					
7	Operation Mode (Setting)	ModeCommand_XXX	MO		Cool	Dry		Fan	Auto	Heat
8	Operation Mode (Status)	ModeStatus_XXX	MI		Cool	Dry		Fan	Auto	Heat
9	Swing (Setting)	SwingCommand_XXX	BO	Stop	Run					
10	Swing (Status)	SwingStatus_XXX	BI	Stop	Run					
11	Fan Speed (Setting)	FanSpeedCommand_XXX	MO		Low	Middle		High	Auto	
12	Fan Speed (Status)	FanSpeedStatus_XXX	MI		Low	Middle		High	Auto	
13	Set Room Temperature	SetRoomTemp_XXX	AV	°C						
14	Room Temperature	RoomTemp_XXX	AI	°C						
15	Alarm	Alarm_XXX	BI	Normal	Abnormal					

Point No.	Control/monitoring	Object Name (XXX : Unit address)	Object Type	Unit		Active					
				Inactive Text-0	Text-1	Text-2	Text-3	Text-4	Text-5		
16	Error Code	MalfunctionCode_XXX			Reference LG Original Error Code						
17	-	-	-								
18	-	-	-								
19	Set Temperature Status	SetTempStatus_XXX	AI	°C							
20	Power Distribution	AccumPowerStatus_XXX	AI	Wattage values (Unit : 100Watt)							
27	Set Upper Temperature Setting	SetUpperTempCommand_XXX	AV	°C							
28	Set Lower Temperature Setting	SetLowerTempCommand_XXX	AI	°C							
29	Set Upper Temperature Status	SetUpperTempStatus_XXX	AI	°C							
30	Set Lower Temperature Status	SetLowerTempStatus_XXX	AI	°C							
31	Mode Lock Setting	ModelockCommand_XXX	BO	Permit	Prohibit						
32	Mode Lock Status	ModelockStatus_XXX	BI	Permit	Prohibit						
33	Fan Lock Setting	FanLockCommand_XXX	BO	Permit	Prohibit						
34	Fan Lock Status	FanLockStatus_XXX	BI	Permit	Prohibit						

Point No.	Control/monitoring	Object Name (XXX : Unit address)	Object Type	Unit		Active Text-1	Text-2	Text-3	Text-4	Text-5
				Inactive Text-0						
35	Occupancy (Setting)	OccupancyCommand_XXX	BO	Unoccupied	Occupied					
36	Occupancy (Status)	OccupancyStatus_XXX	BI	Unoccupied	Occupied					
37	2Set Cooling Set Temperature (Setting)	2SetCoolingTempCommand_XXX	AV	°C						
38	2Set Cooling Set Temperature (Status)	2SetCoolingTempStatus_XXX	AI	°C						
39	2Set Heating Set Temperature (Setting)	2SetHeatingTempCommand_XXX	AV	°C						
40	2Set Heating Set Temperature (Status)	2SetHeatingTempStatus_XXX	AI	°C						
41	2Set Cooling Upper Temperature (Setting)	2SetCoolingUpperLimitCommand_XXX	AV	°C						
42	2Set Cooling Upper Temperature (Status)	2SetCoolingUpperLimitStatus_XXX	AI	°C						
43	2Set Heating Upper Temperature (Setting)	2SetHeatingUpperLimitCommand_XXX	AV	°C						
44	2Set Heating Upper Temperature (Status)	2SetHeatingUpperLimitStatus_XXX	AI	°C						
45	2Set Cooling Lower Temperature (Setting)	2SetCoolingLowerLimitCommand_XXX	AV	°C						
46	2Set Cooling Lower Temperature (Status)	2SetCoolingLowerLimitStatus_XXX	AI	°C						
47	2Set Heating Lower Temperature (Setting)	2SetHeatingLowerLimitCommand_XXX	AV	°C						
48	2Set Heating Lower Temperature (Status)	2SetHeatingLowerLimitStatus_XXX	AI	°C						
49	Thermo Status (Status)	ThermoStatus_XXX	BI	Off	On					

35 ~ 49 points are effective, in case 2Set Auto Mode of environment setting is enabled. (not supported by PQNFB17C0)

Remarks

• Point NO. 1

1. The command executed is transmitted to the A/C regardless of the status of the A/C.
2. Present_Value property will not be used if a property has never been set in the past.

• Point NO. 2

1. If there is an operation error, the Present_Value property will be set to ACTIVE regardless of whether the A/C is in operation or not.

• Point NO. 7

1. The Present_Value property will be set to "1: Cool" as the default value if property has never been set in the past.
2. The air conditioner will ignore the command to an object that does not have right to select operation mode. Therefore, the controlled/monitored system must not use this object for the air conditioner without the right to select operation mode.

• Point NO. 11

1. The A/C will disregard the command which the object which can't select the operation mode. Therefore, controlled/monitored system shouldn't use the object which can't select the operation mode.

• Point NO. 12

1. Present_value property will be set to "1:Low" as the default result if the property has not been set in the past.

• Point NO. 13

1. This unit is for indoor units only, and the approximate set temperature range is 18 ~ 35 °C.
2. When COV registration is made, the COV will be reported the moment a temperature change of at least 0.5 °C is detected.

• Point NO. 14/ 19

1. This object is for indoor units only, and reports the room temperature data measured by the indoor units.

• Point NO. 16

1. This object's error code descriptions should be referred to the corresponding table at the "Reference LG original Error Code".

• Point NO. 35 ~ 49

1. This objects are effective, in case 2Set Auto Mode of environment setting is enabled.

ACP-BAC Point List : Ventilation

One Ventilation unit has a Point List as follows.

Point No.	Control/monitoring	Object Name (XXX : ventilation address)	Object Type	Unit		Active				
				Inactive Text-0	Active Text-1	Text-2	Text-3	Text-4	Text-5	
1	ON/OFF (Setting)	StartStopCommand_XXX	BO	Stop	Start					
2	ON/OFF (Status)	StartStopStatus_XXX	BI	Stop	Run					
3	Lock (Setting)	LockCommand_XXX	BO	Permit	Prohibit					
4	Lock (Status)	LockStatus_XXX	BI	Permit	Prohibit					
5	Filter Sign	Filter Sign_XXX	BI	Off	On					
6	Filter Sign Reset	Filter Sign Reset_XXX	BV	-	Reset					
7	Operation Mode (Setting)	ModeCommand_XXX	MO		Heat Exchange	Auto	Normal			
8	Operation Mode (Status)	ModeStatus_XXX	MI		Heat Exchange	Auto	Normal			
9	-	-								
10	-	-								
11	Fan Speed (Setting)	FanSpeedCommand_XXX	MO		Low	High	Super High	Auto		
12	Fan Speed (Status)	FanSpeedStatus_XXX	MI		Low	High	Super High	Auto		
13	-	-								
14	-	-								
15	Alarm	Alarm_XXX	BI	Off	On					

Point No.	Control/monitoring	Object Name (XXX : ventilation address)	Object Type	Unit		Reference LG Original Error Code					
				Inactive Text-0	Active Text-1	Text-2	Text-3	Text-4	Text-5		
16	Error Code	MalfunctionCode_XXX	AI								
17	User Mode(Setting)	UserModeCommand_XXX	MO	Quick Fresh	Energy Saving	Heater					
18	User Mode(Status)	UserModeStatus_XXX	MI	Quick Fresh	Energy Saving	Heater					
19				°C							
20	-	-	-								
21	AC Operation Mode (setting)	HrvModeCommand_XXX	MO		Cool	Auto	Heat				
22	AC Operation Mode (status)	HrvModeStatus_XXX	MI		Cool	Auto	Heat				
23	AC ON/OFF (setting)	HrvStartStopCommand_XXX	BO	Stop	Run						
24	AC ON/OFF (status)	HrvStartStopStatus_XXX	BI	Stop	Run						
25	AC Humidify (setting)	HrvHumidifyCommand_XXX	BO	Off	On						
26	AC Humidify (status)	HrvHumidifyStatus_XXX	BI	Off	On						

Remarks

- **Point NO. 1**

1. The command executed is transmitted to the A/C regardless of the status of the A/C.
2. Present_Value property will not be used if a property has never been set in the past.

- **Point NO. 2**

1. If there is an operation error, the Present_Value property will be set to ACTIVE regardless of whether the A/C is in operation or not.

- **Point NO. 5**

1. This object supports the Intrinsic Reporting function. When the Present_Value property changes, the corresponding Event will be transmitted if the Event has been registered.

- **Point NO. 6**

1. During a read operation of the Present_Value property, the Filter Limit Sign Reset will be always the same value as the Filter Limit Sign object.
2. Only if INACTIVE is written to the Present_Value property during a write operation, the filter sign information resets ON signs and nothing will be executed even if ACTIVE is written.
3. This object supports the Intrinsic Reporting function. When the Present_Value property changes, the corresponding Event will be transmitted if the Event has been registered.

- **Point NO. 7**

1. The Present_Value property will be set to "1: Cool" as the default value if property has never been set in the past.
2. The air conditioner will ignore the command to an object that does not have right to select operation mode. Therefore, the controlled/monitored system must not use this object for the air conditioner without the right to select operation mode.

- **Point NO. 11**

1. The A/C will disregard the command which the object which can't select the operation mode. Therefore, controlled/monitored system shouldn't use the object which can't select the operation mode.

- **Point NO. 12**

1. Present_value property will be set to "1:Low" as the default result if the property has not been set in the past.

- **Point NO. 16**

1. This object's error code descriptions should be referred to the corresponding table at the "Reference LG original Error Code".

- **Point NO. 17**

1. This object is for vent only, and will not apply if the property has not been set in the past.

- **Point NO. 18**

1. This object is for vent only, and will not apply if the property has not been in the past.

ACP-BAC Point List : AHU

One AHU unit has a Point List as follows.

Point No.	Control/monitoring	Object Name (XXX : AHU address)	Object Type	Unit		Active				
				Inactive Text-0	Text-1	Text-2	Text-3	Text-4	Text-5	
1	ON/OFF (Setting)	StartStopCommand_XXX	BO	Stop	Run					
2	ON/OFF (Status)	StartStopStatus_XXX	BI	Stop	Run					
3	Lock (Setting)	LockCommand_XXX	BO	Permit	Prohibit					
4	Lock (Status)	LockStatus_XXX	BI	Permit	Prohibit					
5	Filter Sign	Filter Sign_XXX	BI	Off	On					
6	Filter Sign Reset	Filter Sign Reset_XXX	BV	-	Reset					
7	Operation Mode (Setting)	ModeCommand_XXX	MO		Cool	Dry	Fan	Heat		
8	Operation Mode (Status)	ModeStatus_XXX	MI		Cool	Dry	Fan	Heat		
9	-	-								
10	-	-								
11	-	-								
12	-	-								
13	Set Room Temperature	SetRoomTemp_XXX	AV	°C						
14	Room Temperature	RoomTemp_XXX	AI	°C						
15	Alarm	Alarm_XXX	BI	Normal	Abnormal					
16	Error Code	MalfunctionCode_XXX	AI							Reference LG Original Error Code

Point No.	Control/monitoring	Object Name (XXX : AHU address)	Object Type	Unit		Text-1	Text-2	Text-3	Text-4	Text-5
				Inactive Text-0	Active					
17	-	-								
18	-	-								
19	Set Temperature (Status)	SetTempStatus_XXX	AI	°C						
20	Emergency Sensor (Setting)	EmergencySensorCommand_XXX	BO	Stop	Run					
21	Emergency Sensor (Status)	EmergencySensorStatus_XXX	BI	Stop	Run					
22	Set Humidify (Setting)	SetHumidifyCommand_XXX	AV	40~60						
23	Set Humidify (Status)	SetHumidifyStatus_XXX	AI	40~60						
24	Humidify (Setting)	HumidifyCommand_XXX	BO	Stop	Run					
25	Humidify (Status)	HumidifyStatus_XXX	BI	Stop	Run					
26	Auto Ventilation (Setting)	AutoVentilCommand_XXX	BO	Stop	Run					
27	Auto Ventilation (Status)	AutoVentilStatus_XXX	BI	Stop	Run					
28	Supply Temperature (Status)	SupplyTempStatus_XXX	AI	-127~127						
29	Outdoor Temperature (Status)	OutdoorTempStatus_XXX	AI	-127~127						
30	Mix Temperature (Status)	MixTempStatus_XXX	AI	-127~127						
31	Supply Humidity (Status)	SupplyHumidifyStatus_XXX	AI	30~90						
32	Outdoor Humidity (Status)	OutdoorHumidifyStatus_XXX	AI	30~90						
33	Ventilation Humidity (Status)	VentilHumidifyStatus_XXX	AI	30~90						
34	CO ₂ Value (Status)	CO2ValueStatus_XXX	AI	0~255 (Real Value = Value*10, Example : In case Value is 20, CO ₂ is 20*10=200ppm)						
35	Humidify Unit (Status)	HumidifyUnitStatus_XXX	BI	Stop	Run					
36	Heater Unit (Status)	HeaterUnitStatus_XXX	BI	Stop	Run					

Point No.	Control/monitoring	Object Name (XXX : AHU address)	Object Type	Unit		Text-2	Text-3	Text-4	Text-5
				Inactive	Active				
				Text-0	Text-1				
37	Ventilation FAN (Status)	VentilFANStatus_XXX	BI	Stop	Run				
38	Supply FAN (Status)	SupplyFANStatus_XXX	BI	Stop	Run				
39	Current OA Damper (Status)	CurOADamperStatus_XXX	AI	0~90					
40	Current EA Damper (Status)	CurEADamperStatus_XXX	AI	0~90					
41	Current MIX Damper (Status)	CurMixDamperStatus_XXX	AI	0~90					
42	Cool OA Damper (Setting)	OADamperCoolCommand_XXX	AV	0~90					
43	Cool OA Damper (Status)	OADamperCoolStatus_XXX	AI	0~90					
44	Cool EA Damper (Setting)	EADamperCoolCommand_XXX	AV	0~90					
45	Cool EA Damper (Status)	EADamperCoolStatus_XXX	AI	0~90					
46	Cool MIX Damper (Setting)	MixDamperCoolCommand_XXX	AV	0~90					
47	Cool MIX Damper (Status)	MixDamperCoolStatus_XXX	AI	0~90					
48	Heat OA Damper (Setting)	OADamperHeatCommand_XXX	AV	0~90					

Point No.	Control/monitoring	Object Name (XXX : AHU address)	Object Type	Unit		Text				
				Inactive	Active	Text-1	Text-2	Text-3	Text-4	Text-5
				Text-0						
49	Heat OA Damper (Status)	OADamperHeatStatus_XXX	AI	0-90						
50	Heat EA Damper (Setting)	EADamperHeatCommand_XXX	AV	0-90						
51	Heat EA Damper (Status)	EADamperHeatStatus_XXX	AI	0-90						
52	Heat MIX Damper (Setting)	MixDamperHeatCommand_XXX	AV	0-90						
53	Heat MIX Damper (Status)	MixDamperHeatStatus_XXX	AI	0-90						
54	Fan OA Damper (Setting)	OADamperFANCommand_XXX	AV	0-90						
55	Fan OA Damper (Status)	OADamperFANStatus_XXX	AI	0-90						
56	Fan EA Damper (Setting)	EADamperFANCommand_XXX	AV	0-90						
57	Fan EA Damper (Status)	EADamperFANStatus_XXX	AI	0-90						
58	Fan MIX Damper (Setting)	MixDamperFANCommand_XXX	AV	0-90						
59	Fan MIX Damper (Status)	MixDamperFANStatus_XXX	AI	0-90						

Remarks

- **Point NO. 1**

1. The command executed is transmitted to the A/C regardless of the status of the A/C.
2. Present_Value property will not be used if a property has never been set in the past.

- **Point NO. 2**

1. If there is an operation error, the Present_Value property will be set to ACTIVE regardless of whether the A/C is in operation or not.

- **Point NO. 5**

1. This object supports the Intrinsic Reporting function. When the Present_Value property changes, the corresponding Event will be transmitted if the Event has been registered.

- **Point NO. 6**

1. During a read operation of the Present_Value property, the Filter Limit Sign Reset will be always the same value as the Filter Limit Sign object.
2. Only if INACTIVE is written to the Present_Value property during a write operation, the filter sign information resets ON signs and nothing will be executed even if ACTIVE is written.
3. This object supports the Intrinsic Reporting function. When the Present_Value property changes, the corresponding Event will be transmitted if the Event has been registered.

- **Point NO. 7**

1. The Present_Value property will be set to "1: Cool" as the default value if property has never been set in the past.
2. The air conditioner will ignore the command to an object that does not have right to select operation mode. Therefore, the controlled/monitored system must not use this object for the air conditioner without the right to select operation mode.

- **Point NO. 13**

1. This unit is for indoor units only, and the approximate set temperature range is 18 ~ 35 °C.
2. When COV registration is made, the COV will be reported the moment a temperature change of at least 0.5 °C is detected.

- **Point NO. 14**

1. This object is for indoor units only, and reports the room temperature data measured by the indoor units.

- **Point NO. 16**

1. This object's error code descriptions should be referred to the corresponding table at the "Reference LG original Error Code".

ACP-BAC Point List : ODU

One ODU unit has a Point List as follows.

ACP BACnet ODU Point List may not be supported depending on the product.

If an ODU system has two or more outdoor units then the point list of only the master unit is supported - not any of the slave units.

Some points may display only zero (0) value depending on the ODU product model.

Point No.	Control/monitoring	Object Name (XXX : ODU address)	Object Type	Unit		Active				
				Inactive Text-0	Text-1	Text-2	Text-3	Text-4	Text-5	
1	Compressor Operation Status	CompOperStatus_XXX	BI	Stop	Run					
2	Refrigerant Type	RefrigerantType_XXX	MI		R407C	422	R410A			
3	Inverter Fan 1 frequency	InverterFanFreq_XXX	AI	-						
4	High Pressure	HighPressure_XXX	AI	-						
5	Low Pressure	LowPressure_XXX	AI	-						
6	Suction Temperature	SuctionTemp_XXX	AI	°C						
7	Liquid Pipe Temperature	LiquidPipeTemp_XXX	AI	°C						
8	Heat Exchanger Temperature	HexTemp_XXX	AI	°C						
9	Outdoor EEV	OutdoorEEV_XXX	AI	-						
10	Subcool EEV	SubCoolEEV_XXX	AI	-						
11	Hot Gas Valve	HotGasValve_XXX	BI	Stop	Run					
12	Inverter Discharge Temperature	InverterDischargeTemp_XXX	AI	°C						
13	Outdoor Temperature	OutdoorTemp_XXX	AI	°C						
14	Operation Mode	OperationMode_XXX	MI		Stop	Cool	Heat			

ACP-BAC Point List : AWHP

One AWHP unit has a Point List as follows.

Point No.	Control/monitoring	Object Name (XXX : AWHP address)	Object Type	Unit		Active				
				Inactive Text-0	Text-1	Text-2	Text-3	Text-4	Text-5	
1	Run/Stop (setting)	StartStopCommand_XXX	BO	Stop	Run					
2	Run/Stop (status)	StartStopStatus_XXX	BI	Stop	Run					
3	Lock (setting)	LockCommand_XXX	BO	Stop	Run					
4	Lock (status)	LockStatus_XXX	BI	Stop	Run					
5	Operation Mode (setting)	ModeCommand_XXX	MO		Cool	Heat	Auto			
6	Operation Mode (status)	ModeStatus_XXX	MI		Cool	Heat	Auto			
7	Set Room Temperature (setting)	SetRoomTempCommand_XXX	AO							
8	Set Room Temperature (status)	SetRoomTempStatus_XXX	AI							
9	Set Hot Water Temperature (setting)	SetHotWaterTempCommand_XXX	AO							
10	Set Hot Water Temperature (status)	SetHotWaterTempStatus_XXX	AI							
11	Set PipeOut Water Temperature (setting)	SetPipeOutWaterTempCommand_XXX	AO							
12	Set PipeOut Water Temperature (status)	SetPipeOutWaterTempStatus_XXX	AI							

Point No.	Control/monitoring	Object Name (XXX : AWHP address)	Object Type	Unit		Reference LG Original Error Code				
				Inactive	Active	Text-1	Text-2	Text-3	Text-4	Text-5
				Text-0	Text-1					
13	Setting Temperature Reference (Air/Water)	AirWaterFlag_XXX	BI	Air	Water					
14	Hot Water Only Mode	HotWaterOnlyFlag_XXX	BI	Normal	Hot Water Only					
15	Current Room Temperature	RoomTemp_XXX	AI							
16	Alarm Event	Alarm_XXX	BI	No error	Error					
17	Malfunction Code	MalfunctionCode_XXX	AI							
18	HotWater On/Off (setting)	HotWaterCommand_XXX	BO							
19	HotWater On/Off (status)	HotWaterStatus_XXX	BI							
20	Pipe Inlet Temperature Status	PipeInTempStatus_XXX	AI							
21	Water Tank Temperature Status	TankTempStatus_XXX	AI							
22	Solar Temperature Status	SolarTempStatus_XXX	AI							
23	Pipe Outlet Temperature Status	PipeOutTempStatus_XXX	AI							

ACP-BAC Point List : GENERAL

ACP BACnet has a GENERAL Point List as follows.

Some of GENERAL Points may not be supported depending on the product.

The product should be rebooted when temperature unit setting is modified.

Point No.	Control/monitoring	Object Name (XXX : Unit address)	Object Type	Unit		Text-1	Text-2	Text-3	Text-4	Text-5
				Inactive Text-0	Active					
1	All Unit Run/Stop (Setting)	AllStartStopCommand	BO	Stop	Run					
2	All Unit Set Room Temperature (Setting)	AllSetRoomTempCommand	AV	°C						
3	All Unit Temperature Lock (Setting)	AllTempLockCommand	AV	°C						
4	Total Accumulated Power (Status)	TotalAccumulatedPower	AI							
5	Peak Control Operation (Setting)	PeakStartStopCommand	BO	Stop	Run					
6	Peak Control Operation (Status)	PeakStartStopStatus	BI	Stop	Run					
7	Peak Shift Time(Setting)	PeakShiftTimeCommand	AV	Minute						
8	Peak Shift Time(Status)	PeakShiftTimeStatus	AI	Minute						
9	Peak Target Ratio(Setting)	PeakTargetCommand	AV	%						
10	Peak Target Ratio(Status)	PeakTargetStatus	AI	%						
11	Peak Current Running Ratio(Status)	PeakCurrentStatus	AI	%						
12	Remote Shutdown(Setting)	RemoteShutDownCommand	BO	Normal	Shutdown					
13	Temperature Unit Setting (Setting)	TempUnitCommand	BO	°C	'F					
14	Temperature Unit Setting (Status)	TempUnitStatus	BI	°C	'F					

Local Definition of Object ID - The instance number is a pair, this consists of the indoor unit No. and item.

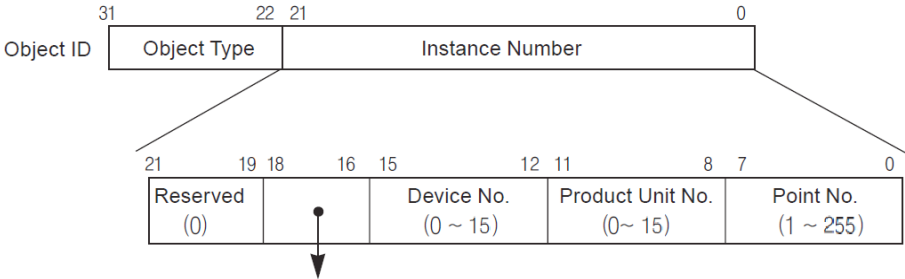

Product Type(Indoor:0, Vent:1, AHU:2, ODU:3, AWHP:4, GENERAL:5)

**Device : Group of Product units(16EA)

Example of Point Table

The point table below is passed to BMS, and BMS registers the object.

Case Indoor

Address	Object Type	Device No.	Product No.	Point	Instance No.	Name
0	4	0	0	1	0×00001(1)	ON/OFF : setting
0	3	0	0	2	0×00002(2)	ON/OFF : status
1	4	0	1	1	0×00101(257)	ON/OFF : setting
1	3	0	1	2	0×00102(258)	ON/OFF : status
15	4	0	15	1	0×00F01(3841)	ON/OFF : setting
15	3	0	15	2	0×00F02(3842)	ON/OFF : status
16	4	1	0	1	0×01001(4097)	ON/OFF : setting
16	3	1	0	2	0×01002(4098)	ON/OFF : status
17	4	1	1	1	0×01101(4353)	ON/OFF : setting
17	3	1	1	2	0×01102(4354)	ON/OFF : status
31	4	1	15	1	0×01F01(7937)	ON/OFF : setting
31	3	1	15	2	0×01F02(7938)	ON/OFF : status
32	4	2	0	1	0×02001(8193)	ON/OFF : setting
32	3	2	0	2	0×02002(8194)	ON/OFF : status
33	4	2	1	1	0×02101(8449)	ON/OFF : setting

Address	Object Type	Device No.	Product No.	Point	Instance No.	Name
33	3	2	1	2	0×02102(8450)	ON/OFF : status
47	4	2	F	1	0×02F01(12033)	ON/OFF : setting
47	3	2	15	2	0×02F02(12034)	ON/OFF : status

Case Vent

Address	Object Type	Device No.	Product No.	Point	Instance No.	Name
0	4	0	0	1	0×10001(65537)	ON/OFF : setting
0	3	0	0	2	0×10002(65538)	ON/OFF : status
1	4	0	1	1	0×10101(65793)	ON/OFF : setting
1	3	0	1	2	0×10102(65794)	ON/OFF : status
15	4	0	15	1	0×10F01(69377)	ON/OFF : setting
15	3	0	15	2	0×10F02(69378)	ON/OFF : status
16	4	1	0	1	0×11001(69633)	ON/OFF : setting
16	3	1	0	2	0×11002(69634)	ON/OFF : status
17	4	1	1	1	0×11101(69889)	ON/OFF : setting
17	3	1	1	2	0×11102(69890)	ON/OFF : status
31	4	1	15	1	0×11F01(73473)	ON/OFF : setting
31	3	1	15	2	0×11F02(73474)	ON/OFF : status
32	4	2	0	1	0×12001(73729)	ON/OFF : setting
32	3	2	0	2	0×12002(73730)	ON/OFF : status
33	4	2	1	1	0×12101(73985)	ON/OFF : setting
33	3	2	1	2	0X12102(73986)	ON/OFF : status
47	4	2	F	1	0×12F01(77569)	ON/OFF : setting
47	3	2	15	2	0×12F02(77570)	ON/OFF : status

Case AHU

Address	Object Type	Device No.	Product No.	Point	Instance No.	Name
0	4	0	0	1	20001(131073)	ON/OFF : setting
0	3	0	0	2	20002 (131074)	ON/OFF : status
1	4	0	1	1	20101 (131329)	ON/OFF : setting

Address	Object Type	Device No.	Product No.	Point	Instance No.	Name
1	3	0	1	2	20102 (131330)	ON/OFF : status
15	4	0	15	1	20F01 (134913)	ON/OFF : setting
15	3	0	15	2	20F02 (134914)	ON/OFF : status

Objects (Modbus-TCP)

Supported Function Code

Monitoring and controlling items of air conditioners supported are assigned with general function codes specified by Modbus-TCP.

Function Name	Code	Description
Read Single Coil	01h	Run/Stop(status), Lock(status), Swing(status), Alarm, Filter Sign(status), Mode Lock(status), Wind Flow Lock(status)
Read Holding Registers	03h	Operation Mode(status), Fan Speed(status), Room Temperature, Error Code, Set Room Temperature(status), Set Lower Temperature(status), Set Upper Temperature(status), User Mode(status)
Write Single Coil	05h	Run/Stop(setting), Lock(setting), Swing(setting), Filter Sign Reset, Mode Lock(setting), Wind Flow Lock(setting)
Write Single Registers	06h	Operation Mode(setting), Fan Speed(setting), Set Room Temperature(setting), Set Lower Temperature(setting), Set Upper Temperature(setting), User Mode(setting)

Modbus Point List : Indoor Unit

Function Code : 0x01 and 0x05

Register	Function	Name	Object Name (XXX : Unit address)	Inactive	Active
1	Read Single Coil	ON/OFF	StartStopStatus_XXX	Stop	Run
2		SWING	SwingStatus_XXX	Permit	Prohibit
3		LOCK	LockStatus_XXX	Permit	Prohibit
4		MODE LOCK	ModeLockStatus_XXX	Permit	Prohibit
5		FAN LOCK	WindFlowLockStatus_XXX	Permit	Prohibit
6		TEMP LOCK	SetTempStatus-XXX	Permit	Prohibit
7		ALARM	Alarm_XXX	Normal	Abnormal
1	Write Single Coil	ON/OFF	StartStopCommand_XXX	Stop	Run
2		SWING	SwingCommand_XXX	Permit	Prohibit
3		LOCK	LockCommand_XXX	Permit	Prohibit
4		MODE LOCK	ModeLockCommand_XXX	Permit	Prohibit
5		FAN LOCK	WindFlowLockCommand_XXX	Permit	Prohibit
6		TEMP LOCK	SetTempCommand-XXX	Permit	Prohibit

Function Code : 0x03 and 0x06

Register	Function	Name	Object Name (XXX : Unit address)	Text-0	Text-1	Text-2	Text-3	Text-4	Text-5
1	Read Holding Registers	OPERATION MODE	ModeStatus_XXX		Cool	Dry	Fan	Auto	Heat
2		FAN SPEED	FanSpeedStatus_XXX		Low	Middle	High	Auto	
3		SET ROOM TEMPERATURE	SetTempStatus_XXX	°C					
4		UP_SETTEMP	SetUpperTemp Status_XXX	°C					
5		LO_SETTEMP	SetLowerTemp Status_XXX	°C					
6		ROOM TEMPERATURE	RoomTemp_XXX		°C				
7		ERROR CODE	MalfunctionCode_XXX		Reference LG original Error Code				
1	Write Single Registers	OPERATION MODE	ModeCommand_XXX		Cool	Dry	Fan	Auto	Heat
2		FAN SPEED	FanSpeed Command_XXX		Low	Middle	High	Auto	
3		SET ROOM TEMPERATURE	SetTemp Command_XXX	°C					
4		UP_SETTEMP	SetUpperTemp Command_XXX	°C					
5		LO_SETTEMP	SetLowerTemp Command_XXX	°C					

Remarks

• **StartStopStatus_XXX**

1. If there is an operation error, the Present_Value property will be set to ACTIVE regardless of whether the A/C is in operation or not.

• **SetTempStatus-XXX / SetLowerTempStatus_XXX / RoomTemp_XXX**

1. This object is for indoor units only, and reports the room temperature data measured by the indoor units.

• **WrStartStopCommand_XXX**

1. The command executed is transmitted to the A/C regardless of the status of the A/C.
2. The Present_Value property will not be used if a property has never been set in the past.

• **FanSpeedStatus_XXX**

1. The Present_value property will be set to "1:Low" as the default value if the property has never been set in the past.

• **SetUpperTempStatus_XXX**

1. This object is for indoor units only, and reports the set upper temperature data measured by the indoor units.

• **MalfunctionCode_XXX**

1. This object's error code descriptions should be referred to the corresponding table at the "Reference LG original Error Code".

• **ModeCommand_XXX**

1. The Present_Value property will be set to "1: Cool" as the default value if property has never been set in the past.
2. The air conditioner will ignore the command to an object that does not have right to select operation mode. Therefore, the controlled/monitored system must not use this object for the air conditioner without the right to select operation mode.

• **FanSpeed Command_XXX**

1. The A/C will disregard the command which the object which can't select the operation mode. Therefore, controlled/monitored system shouldn't use the object which can't select the operation mode.

• **SetUpperTempCommand_XXX / SetLowerTempCommand_XXX**

1. This unit is for indoor units only, and the approximate set upper(or lower) temperature range is 18 ~ 30 °C.
2. 1 °C is detected.

Modbus Point List : Ventilation

Function Code : 0x01 and 0x05

Register	Function	Name	Object Name (XXX : Ventilation address)	Inactive	Active
1	Coil Read	ON/OFF	StartStopStatus_XXX	Stop	Run
2		LOCK	LockStatus_XXX	Permit	Prohibit
3		FILTER SIGN	FilterSign_XXX	Off	On
4		ALARM	Alarm_XXX	Stop	Run
5		HRV_AC_OPER	HrvStartStopStatus_XXX	Stop	Run
6		HRV_HUMIDIFY	HrvHumidifyStatus_XXX	Off	On
1	Write Single Coil	ON/OFF	StartStopCommand_XXX	Stop	Run
2		LOCK	LockCommand_XXX	Permit	Prohibit
3		FILTER SIGN RESET	FilterSignReset_XXX	Reset(Off)	Void(On)
5		HRV_AC_OPER	HrvStartStopCommand_XXX	Stop	Run
6		HRV_HUMIDIFY	HrvHumidifyCommand_XXX	Off	On

Function Code : 0x03 and 0x06

Register	Function	Name	Object Name (XXX : Ventilation address)	Text-0	Text-1	Text-2	Text-3	Text-4	Text-5	
1	Read Holding Registers	OPERATION MODE	ModeStatus_XXX		Heat Exchange	Auto	Normal			
2		FAN SPEED	FanSpeedStatus_XXX		Low	High	Super High	Auto		
3		USER MODE	UserModeStatus_XXX		Quick Operation	Energy Saving	Heat			
4		ERROR CODE	MalfunctionCode_XXX		Reference LG original Error Code					
5		HRV_AC_MODE	HrvModeStatus_XXX			Cool	Auto	Heat		
6		HRV_SETTEMP	HrvSetTempstatus_XXX		°C					
1	Write Single Registers	OPERATION MODE	ModeCommand_XXX		Heat Exchange	Auto	Normal			
2		FAN SPEED	FanSpeed Command_XXX		Low	High	Super High	Auto		
3		USER MODE	UserModeStatus_XXX		Quick Operation	Energy Saving	Heat			
5		HRV_AC_MODE	HrvModeStatus_XXX		Cool	Auto	Heat			
6		HRV_SETTEMP	HrvSetTempstatus_XXX		°C					

Remarks

• StartStopStatus_XXX

1. If there is an operation error, the Present_Value property will be set to ACTIVE regardless of whether the A/C is in operation or not.

• FilterSign_XXX

1. This object supports the Intrinsic Reporting function. When the Present_Value property changes, the corresponding Event will be transmitted if the Event has been registered.

• StartStopCommand_XXX

1. The command executed is transmitted to the A/C regardless of the status of the A/C.
2. Present_Value property will not be used if a property has never been set in the past.

• FilterSignReset_XXX

1. During a read operation of the Present_Value property, the Filter Limit Sign Reset will be always the same value as the Filter Limit Sign object.
2. Only if INACTIVE is written to the Present_Value property during a write operation, the filter sign information resets ON signs and nothing will be executed even if ACTIVE is written.
3. This object supports the Intrinsic Reporting function. When the Present_Value property changes, the corresponding Event will be transmitted if the Event has been registered.

• FanSpeedStatus_XXX

1. Present_value property will be set to "1:Low" as the default result if the property has not been set in the past.

• UserModeStatus_XXX

1. This object is for vent only, and will not apply if the property has not been in the past.

• MalfunctionCode_XXX

1. This object's error code descriptions should be referred to the corresponding table at the "Reference LG original Error Code".

Modbus Point List : AHU

Function Code : 0x01 and 0x05

Register	Function	Name	Object Name (XXX : AHU address)	Inactive	Active
1	Coil Read	ON/OFF	StartStopStatus_XXX	Stop	Run
2		LOCK	LockStatus_XXX	Permit	Prohibit
3		FILTER SIGN	FilterSign_XXX	Off	On
4		SMOKE	EmergencySensorStatus_XXX	Stop	Run
5		HUMIDITY	HumidifyStatus_XXX	Stop	Run
6		AUTO VENT	AutoVentStatus_XXX	Stop	Run
7		HUMIDIFIER	HumidifyUnitStatus-XXX	Stop	Run
8		HEATER	HeaterUnitStatus_XXX	Stop	Run
9		VENT FAN	VentFANStatus_XXX	Stop	Run
10		SUPPLY FAN	SupplyFANStatus_XXX	Stop	Run
11		ALARM	Alarm_XXX	Normal	Abnormal
1	Write Single Coil	ON/OFF	StartStopCommand_XXX	Stop	Run
2		LOCK	LockCommand_XXX	Permit	Prohibit
4		SMOKE	EmergencySensorCommand_XXX	Stop	Run
5		HUMIDITY	HumidifyCommand_XXX	Stop	Run
6		AUTO VENT	AutoVentCommand_XXX	Stop	Run

Function Code : 0x03

Register	Function	Name	Object Name (XXX : AHU address)	Text-0	Text-1	Text-2	Text-3	Text-4	Text-5
1		MODE	ModeStatus_XXX		Cool	Dry	Fan	POWS- AV	Heat
2		SET TEMP	SetTempStatus_XXX	°C					
3		SUPPLY TEMP	SupplyTempStatus_XXX	-127~127					
4		OUTDOOR TEMP	OutdoorTempStatus_XXX	-127~127					
5		VENT TEMP	VentTempStatus_XXX	-127~127					
6		MIXING TEMP	MixingTempStatus_XXX	-127~127					
7		SET HUMIDITY	SetHumidityStatus_XXX	40~60					
8		SUPPLY HUMIDITY	SupplyHumidityStatus_XXX	30~90					
9		OUTDOOR HUMIDITY	OutdoorHumidityStatus_XXX	30~90					
10	Read Holding Registers	VENT HUMIDITY	VentHumidityStatus_XXX	30~90					
11		CO2 VALUE	CO2ValueStatus_XXX	0~255					
12		ERROR CODE	MalfunctionCode_XXX	Reference LG original Error Code					
17		CURR_OA_DAMPER	CurOADamperStatus_XXX	0~90					
18		CURR_EA_DAMPER	CurEADamperStatus_XXX	0~90					
19		CURR_MIX_DAMPER	CurMixDamperStatus_XXX	0~90					
20		COOL_OA_DAMPER	OADamperCoolStatus_XXX	0~90					
21		COOL_EA_DAMPER	EADamperCoolStatus_XXX	0~90					
22		COOL_MIX_DAMPER	MixDamperCoolStatus_XXX	0~90					
23		HEAT_OA_DAMPER	OADamperHeatStatus_XXX	0~90					
24		HEAT_EA_DAMPER	EADamperHeatStatus_XXX	0~90					
25		HEAT_MIX_DAMPER	MixDamperHeatStatus_XXX	0~90					

Function Code : 0x03 / 0x06

Register	Function	Name	Object Name (XXX : AHU address)	Text-0	Text-1	Text-2	Text-3	Text-4	Text-5
26	Read Holding Registers	FAN_OA_DAMPER	OADamperFANStatus_XXX	0~90					
27		FAN_EA_DAMPER	EADamperFANStatus_XXX	0~90					
28		FAN_MIX_DAMPER	MixDamperFANStatus_XXX	0~90					
1		MODE	ModeCommand_XXX		Cool	Dry	Fan	POWS- AV	Heat
2		SET TEMP	SetTempCommand_XXX	°C					
7		SET HUMIDITY	SetHumidityCommand_XXX	40~60					
20		COOL_OA_DAMPER	CoolOADamperCommand_XXX	0~90					
21		COOL_EA_DAMPER	CoolEADamperCommand_XXX	0~90					
22	Write Single Registers	COOL_MIX_DAMPER	CoolMixDamperCommand_XXX	0~90					
23		HEAT_OA_DAMPER	HeatOADamperCommand_XXX	0~90					
24		HEAT_EA_DAMPER	HeatEADamperCommand_XXX	0~90					
25		HEAT_MIX_DAMPER	HeatMixDamperCommand_XXX	0~90					
26		FAN_OA_DAMPER	FANOADamperCommand_XXX	0~90					
27		FAN_EA_DAMPER	FANEADamperCommand_XXX	0~90					
28		FAN_MIX_DAMPER	FANMixDamperCommand_XXX	0~90					

Remarks

- **StartStopStatus_XXX**

1. If there is an operation error, the Present_Value property will be set to ACTIVE regardless of whether the A/C is in operation or not.

- **FilterSign_XXX**

1. This object supports the Intrinsic Reporting function. When the Present_Value property changes, the corresponding Event will be transmitted if the Event has been registered.

- **StartStopCommand_XXX**

1. The command executed is transmitted to the A/C regardless of the status of the A/C.
2. Present_Value property will not be used if a property has never been set in the past.

- **MalfunctionCode_XXX**

1. This object's error code descriptions should be referred to the corresponding table at the "Reference LG original Error Code".

- **ModeCommand_XXX**

1. The Present_Value property will be set to "1: Cool" as the default value if property has never been set in the past.
2. The air conditioner will ignore the command to an object that does not have right to select operation mode. Therefore, the controlled/monitored system must not use this object for the air conditioner without the right to select operation mode.

Local Definition of Object ID - The instance number is a pair, this consists of the indoor unit No. and item.

Example of Point Table

The point table below is passed to BMS, and BMS registers the object.

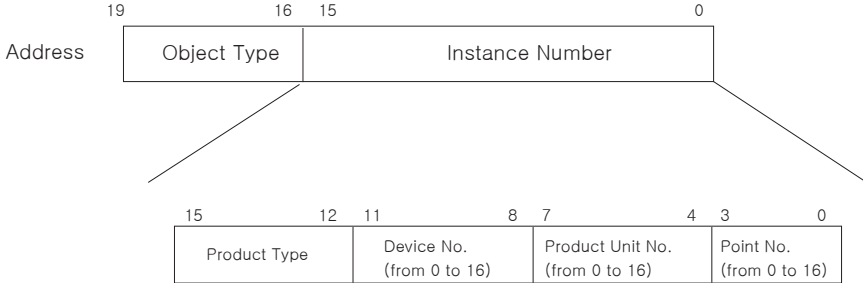

- * Object Type (Coil : 0, Register : 4)
- * Product Type (Indoor : 0, Vent : 4, AHU : 8)
- ** Device : Group of Product units (16EA)

Case Indoor

Function Code	Device No.	Product No.	Point	Instance No.	Name
1	0	0	0	0x00000	ON/OFF status
5	0	0	0	0x00000	ON/OFF Setting
1	0	1	0	0x00010	ON/OFF status
5	0	1	0	0x00010	ON/OFF Setting
1	1	0	0	0x00100	ON/OFF status
5	1	0	0	0x00100	ON/OFF Setting
3	0	0	0	0x40000	Mode status
6	0	0	0	0x40000	Mode Setting
3	0	1	0	0x40010	Mode status
6	0	1	0	0x40010	Mode Setting
3	1	0	0	0x40100	Mode status
6	1	0	0	0x40100	Mode Setting

Case Vent

Function Code	Device No.	Product No.	Point	Instance No.	Name
1	0	0	0	0x04000	ON/OFF status
5	0	0	0	0x04000	ON/OFF Setting
1	0	1	0	0x04010	ON/OFF status
5	0	1	0	0x04010	ON/OFF Setting
1	1	0	0	0x04100	ON/OFF status
5	1	0	0	0x04100	ON/OFF Setting
3	0	0	0	0x44000	Mode status
6	0	0	0	0x44000	Mode Setting
3	0	1	0	0x44010	Mode status
6	0	1	0	0x44010	Mode Setting
3	1	0	0	0x44100	Mode status
6	1	0	0	0x44100	Mode Setting

Case AHU

Function Code	Device No.	Product No.	Point	Instance No.	Name
1	0	0	0	0x08000	ON/OFF status
5	0	0	0	0x08000	ON/OFF Setting
1	0	1	0	0x08010	ON/OFF status
5	0	1	0	0x08010	ON/OFF Setting
1	1	0	0	0x08100	ON/OFF status
5	1	0	0	0x08100	ON/OFF Setting
3	0	0	0	0x48000	Mode status
6	0	0	0	0x48000	Mode Setting
3	0	1	0	0x48010	Mode status
6	0	1	0	0x48010	Mode Setting
3	1	0	0	0x48100	Mode status
6	1	0	0	0x48100	Mode Setting

Initialization at the Start Up

The system is designed to automatically recognize the connected air conditioners. Therefore, a period of approximately one minute will be required to recognize all the air conditioners after the system is turn on. During this period, the following error PDU may be returned when an object corresponding to an air conditioner is accessed.

ErrorClass = Object; ErrorCode = Unknown_Object

If an attempt is made to read the Object List property of the Device object from an air conditioner during the above period of recognition, the following error PDU will be returned, unless the air conditioner has been recognize:

ErrorClass = Device; ErrorCode = Configuration_In_Progress

Communication error response of ACP BACnet, please refer to **refer to ACP-BACnet Error Response Table on page 95**.

Clock Setting

The Timesynchronization service allows clock settings by the local time.

Furthermore, the UTCTimesynchronization allows clock settings by UTC

Report Function

Event Notification

1) Registration of Event Notification Destination

It is possible to use the AddListElement service to register notification destination information on the Recipient List property of the Notification Class object.

2) Deletion of Event Notification Destination

The RemoveListElement service can be used to delete notification destination information from the Notification Class object.

3) Event Notification Destination in Memory

The registered event notification destination is stored in the memory. When the system is turned on, the event notification destination will be initialized with the stored information. The Event notification destination will be stored five seconds after the registration or deletion.

COV(Change of Value) Notification

A request for COV registration is accepted through the SubscribeCOV service.

1) Setting of Confirmed or Unconfirmed COV

This item is supported according to the BACnet Specifications.

2) Setting of the desired lifetime of the subscription

This item is supported according to the BACnet Specifications.

When COV notification is made at the time of status change, the difference between the registered time and present time will be calculated. If the difference is greater than the registered lifetime of the subscription, the subscription will be judged expired and deleted. Therefore, if a clock time change is made, the lifetime of the subscription may differ from the value that has been set.

3) Memory after Interruption of Power Supply to System

This item is not supported. Registration information is not stored in the memory, and will be lost when the power is turned off. According to the BACnet Specifications, It is not required to guarantee preservation of subscriptions across power failure.

NOTES

Troubleshooting

During the use of the ACP BACnet, if unexpected problem occurs, please find the solution by studying the following list. If there is no solution, please access www.lgservice.co.kr to report the problem.

When Tx or Rx LED of CH1~4 port is not blinking during the product installation

When Tx or Rx LED of CH1~4 port is not blinking during the product installation, run it after setting the indoor and outdoor unit groups.

When GUI cannot be operated in Web GUI, which is the operation program of the ACP BACnet

1. When GUI cannot be operated in Web GUI, which is the operation program of the ACP BACnet, close Explorer window, and run new Explorer to access again.
2. Close all iexplorer.exe process in Task Manager, and access to the ACP BACnet again.
 - After running Task Manager, you can select 'Task Manager' in the popup menu window displayed by clicking the right button of the mouse on the menu bar of the window.

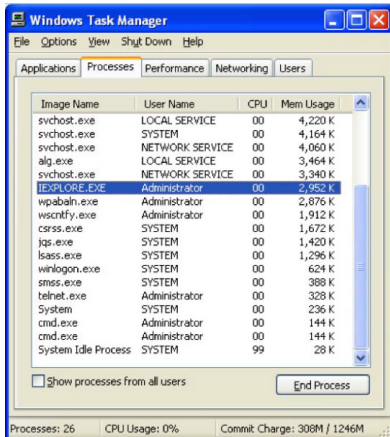

When the ventilation equipment is displayed as a network error state (code 242) in LG Web GUI of the ACP BACnet

When the ventilation equipment is displayed as a network error state (code 242) as followed, in Web GUI, which is the web server program of the ACP BACnet, please check the following categories.

- Check if the BUS-A and BUS-B of RS-485 cable are incorrectly connected.
- Check if there is a communication defect between the remote controller and the indoor unit.
- Check if the PI485 DIP switch is incorrectly set.
- Check if the indoor unit address for the central control is not set.

The CH242 (network error) keeps occurring and disappearing in the ACP BACnet controller.

Case of incorrect connection of RS-485 communication line

If each communication line is connected altogether as in the following figure, the communication line must be separated.

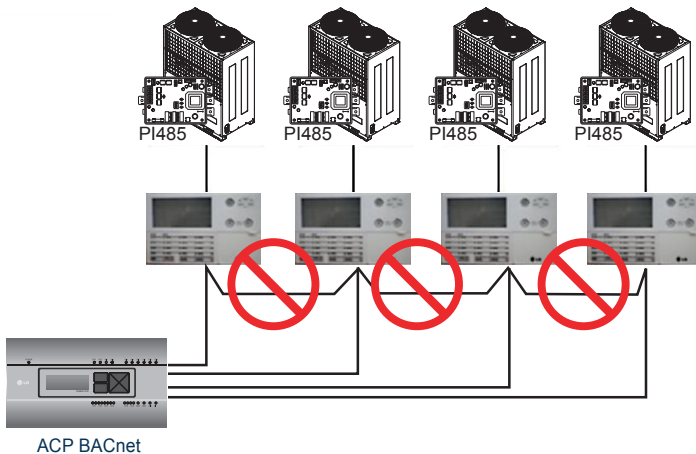

Duplicate setting of the indoor unit address

It is the case of two or more indoor units are set with the same address. It may be the case of several indoor units having the default address 00 by not setting the central control address from the beginning for some indoor units.

In such case, assign unique address to each indoor unit not to have indoor unit with a duplicate address.

It is installed by interfacing 16 room central controller and the ACP BACnet, but some indoor units are not recognized, or not properly performing the central control commands

- It is the case of incorrect setting of the simple central controller (16 room central controller) DIP switch.
Set all simple central controllers to Slave mode, and reset the power.
- If the indoor unit to control with simple central controller is in another physical line as in the following figure, the simple central controller cannot recognize the corresponding indoor unit. Therefore, the connections need to be modified to have the simple central controller to be in the same RS-485 communication line with the indoor unit to control.

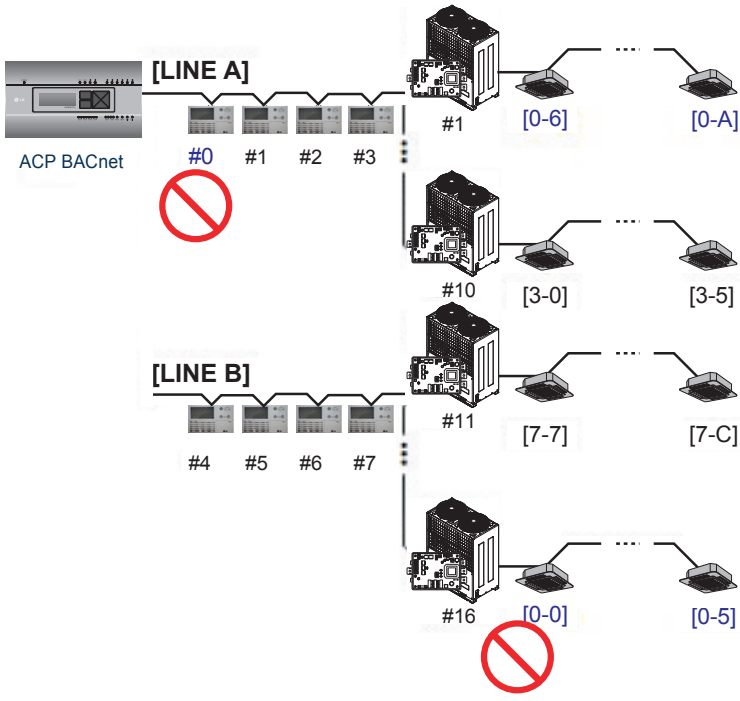

When the outdoor unit is Multi V Super II, and central control is not well performed with 16 room central controller or ACP BACnet, and the indoor units malfunction such as some indoor units automatically becoming locked state or automatically converting to cooling during heating operation

1. PI485 and outdoor unit may not be doubly connected. Please refer to the following picture to check the connection status of the communication line.

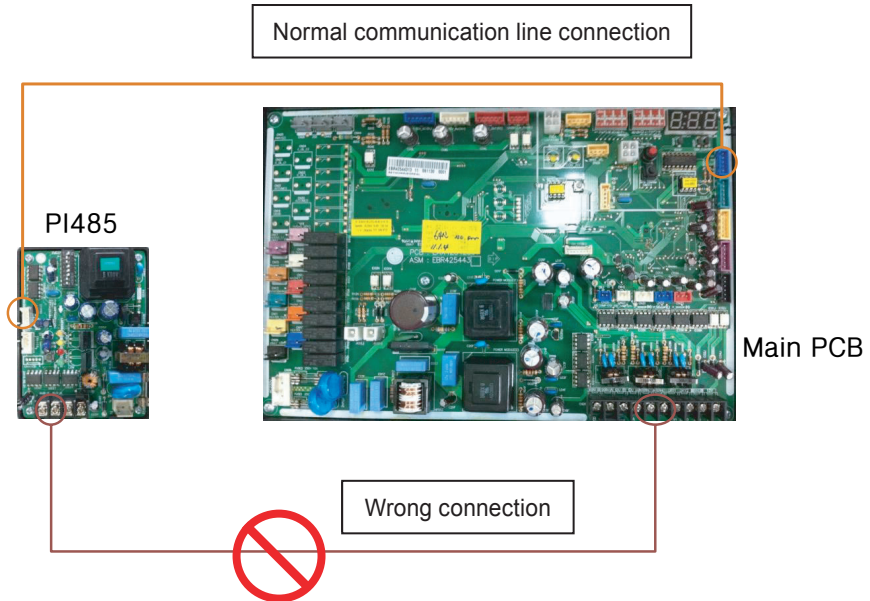

When the image of Web GUI is broken and you cannot see the screen such as the temperature well

1. Close Web GUI, and rerun.



Caution

- If PC is used for a long period of time, or several application programs are used at the same time, PC performance may be degraded and may affect the ACP BACnet UI.
- When you use Web GUI, it is recommended to close other application programs.
- It is recommended to use Web GUI only during the control and monitoring.
(Maximum of 3 hours of usage is recommended according to the PC environment.)

OPEN SOURCE SOFTWARE NOTICE

To obtain the source code under GPL, LGPL, MPL and other open source licenses, that is contained in this product, please visit <http://opensource.lge.com>.

In addition to the source code, all referred license terms, warranty disclaimers and copyright notices are available for download.

LG Electronics will also provide open source code to you on CD-ROM for a charge covering the cost of performing such distribution (such as the cost of media, shipping and handling) upon email request to opensource@lge.com. This offer is valid for three (3) years from the date on which you purchased the product.

BIBBs

ACP BACnet Interoperability Building Blocks Supported(BIBBs)

Data Sharing BIBBS

(□:Not supported,■: Support)

BIBB Type		Supported	ACP BACnet Service	Initiate	Execute
DS-RP-A	Data Sharing-ReadProperty-A	□	ReadProperty	×	
DS-RP-B	Data Sharing-ReadProperty-B	■	ReadProperty		×
DS-RPM-A	Data Sharing-ReadProperty-Multiple-A	□	ReadPropertyMultiple	×	
DS-RPM-B	Data Sharing-ReadProperty-Multiple-B	■	ReadPropertyMultiple		×
DS-RPC-A	Data Sharing-ReadPropertyConditional-A	□	ReadPropertyConditional	×	
DS-RPC-B	Data Sharing-ReadPropertyConditional-B	□	ReadPropertyConditional		×
DS-WP-A	Data Sharing-WriteProperty-A	□	WriteProperty	×	
DS-WP-B	Data Sharing-WriteProperty-B	■	WriteProperty		×
DS-WPM-A	Sharing-WritePropertyMultiple-A	□	WritePropertyMultiple	×	
DS-WPM-B	Data Sharing-WriteProperty-Multiple-B	■	WritePropertyMultiple		×
DS-COV-A	Data Sharing-COV-A	□	SubscribeCOV	×	
			Confirmed COVNotification		×
			Unconfirmed COVNotification		×
DS-COV-B	Data Sharing-COV-B	■	SubscribeCOV		×
			Confirmed COVNotification	×	
			Unconfirmed COVNotification	×	

BIBB Type		Supported	ACP BACnet Service	Initiate	Execute
DS-COVP-A	Data Sharing-COVP-A	□	SubscribeCOV	x	
			Confirmed COVNotification		x
			Unconfirmed COVNotification		x
DS-COVP-B	Data Sharing-COVP-B	□	SubscribeCOV		x
			Confirmed COVNotification	x	
			Unconfirmed COVNotification	x	
DS-COVU-A	Data Sharing-COV-Unsolicited-A	□	Unconfirmed COVNotification		x
DS-COVU-B	Data Sharing-COV-Unsolicited-B	□	Unconfirmed COVNotification	x	

Alarm and Event Management BIBBS

(□: Not supported, ■: Support)

BIBB Type		Supported	ACP BACnet Service	Initiate	Execute
AE-N-A	Alarm and Event-Notification-A	□	Confirmed EventNotification		×
			Unconfirmed EventNotification		×
AE-N-I-B	Alarm and Event-Notification Internal-B	■	Confirmed EventNotification	×	
			Unconfirmed EventNotification	×	
AE-N-E-B	Alarm and Event-Notification External-B	□	Confirmed EventNotification	×	
			Unconfirmed EventNotification	×	
AE-ACK-A	Alarm and Event-ACK-A	□	AcknowledgeAlarm	×	
AE-ACK-B	Alarm and Event-ACK-B	□	AcknowledgeAlarm		×
AE-ASUM-A	Alarm and Event-Summary-A	□	GetAlarmSummary	×	
AE-ASUM-B	Alarm and Event-Summary-B	□	GetAlarmSummary		×
AE-ESUM-A	Event-Summary-A	□	GetEnrollment Summary	×	
AE-ESUM-B	Event-Summary-B	□	GetEnrollment Summary		×
AE-INFO-A	Alarm and Event-Information-A	□	GetEventInformation	×	
AE-INFO-B	Alarm and Event-Information-B	□	GetEventInformation		×
AE-LS-A	Alarm and Event-LifeSafety-A	□	LifeSafetyOperation	×	
AE-LS-B	Alarm and Event-LifeSafety-B	□	LifeSafetyOperation		×

Scheduling BIBBS

(□:Not supported,■: Support)

BIBB Type		Supported	ACP BACnet Service	Initiate	Execute
SCHED-A	Scheduling-A (must support DS-RP-A and DS-WP-A)	□			
SCHED-I-B	Scheduling-Internal-B (shall support DS-RP-B and DS-WP-B) (shall also support ether DM-TS-B or DS-UTC-B)	□			
SCHED-E-B	Scheduling-External-B (shall support SCHED-I-B and DS-WP-A)	□			

Trending BIBBS

(□:Not supported,■: Support)

BIBB Type		Supported	ACP BACnet Service	Initiate	Execute
T-VMT-A	Trending - Viewing and Modifying Trends-A	□	ReadRange	×	
T-VMT-I-B	Trending-Viewing and Modifying Trends Internal-B	□	ReadRange		×
T-VMT-E-B	Trending-Viewing and Modifying Trends External-B	□	ReadRange		×
T-ATR-A	Trending - Automated Trend Retrieval-A	□	ConfirmedEvent Notification		×
			edEventNoti	×	
T-ATR-B	Trending - Automated Trend Retrieval-B	□	ConfirmedEvent Notification	×	
			edEventNoti		×

Device Management BIBBS

(□: Not supported, ■: Support)

BIBB Type		Supported	ACP BACnet Service	Initiate	Execute
DM-DDB-A	Device Management - Dynamic Device, Binding-A	■	Who-Is	x	
			I-Am		x
DM-DDB-B	Device Management - Dynamic Device, Binding-B	■	Who-Is		x
			I-Am	x	
DM-DOB-A	Device Management - Dynamic Object, Binding-A	□	Who-Has	x	
			I-Have		x
DM-DOB-B	Device Management - Dynamic Object, Binding-B	■	Who-Has		x
			I-Have	x	
DM-DCC-A	Device Management - Device-Communication Control-A	□	DeviceCommunication Control	x	
DM-DCC-B	Device Management - Device-Communication Control-B	□	DeviceCommunication Control		x
DM-PT-A	Device Management - Private-Transfer-A	□	ConfirmedPrivate Transfer	x	
			UnconfirmedPrivate Transfer	x	
DM-PT-B	Device Management - Private-Transfer-B	□	ConfirmedPrivate Transfer		x
			UnconfirmedPrivate Transfer		x
DM-TM-A	Device Management - Text Message-A	□	ConfirmedPrivate Transfer	x	
			UnconfirmedPrivate Transfer	x	
DM-TM-B	Device Management - Text Message-B	□	ConfirmedPrivate Transfer		x
			UnconfirmedPrivate Transfer		x
DM-TS-A	Device Management - TimeSynchronization-A	□	TimeSynchronization	x	
DM-TS-B	Device Management - TimeSynchronization-B	■	TimeSynchronization		x
DM-UTC-A	Device Management - UTCTimeSynchronization-A	□	UTCTime Synchronization	x	

BIBB Type		Supported	ACP BACnet Service	Initiate	Execute
DM-UTC-B	Device Management - UTCTimeSynchronization-B	□	UTCTimeSynchronization		×
DM-RD-A	Device Management - ReinitializeDevice-A	□	ReinitializeDevice	×	
DM-RD-B	Device Management - ReinitializeDevice-B	□	ReinitializeDevice		×

Device Management BIBBS

(□:Not supported,■: Support)

BIBB Type		Supported	ACP BACnet Service	Initiate	Execute
DM-BR-A	Device Management - Backup and Restore-A	□	AtomicReadFile	×	
			AtomicWriteFile	×	
			CreateObject	×	
			ReinitializeDevice	×	
DM-BR-B	Device Management - Backup and Restore-B	□	AtomicReadFile		×
			DMAAtomicWriteFile		×
			ReinitializeDevice		×
DM-R-A	Device Management - Restart-A	□	UnconfirmedCOVNotification		×
DM-R-B	Device Management - Restart-B	□	UnconfirmedCOVNotification	×	
DM-LM-A	Device Management - List Manipulation-A	□	AddListElement	×	
			RemoveListElement	×	
DM-LM-B	Device Management - List Manipulation-B	□	AddListElement		×
			RemoveListElement		×
DM-OCD-A	Device Management - Object Creation and Deletion-A	□	CreateObject	×	
			DeleteObject	×	
DM-OCD-B	Device Management - Object Creation and Deletion-B	□	CreateObject		×
			DeleteObject		×
DM-VT-A	Device Management - Virtual Terminal-A	□	VT-Open	×	
			VT-Close	×	×
			VT-Data	×	×
DM-VT-B	Device Management - Virtual Terminal-B	□	VT-Open		×
			VT-Close	×	×
			VT-Data	×	×

Network Management BIBBS

(□:Not supported,■: Support)

BIBB Type		Supported	ACP BACnet Service	Initiate	Execute
NM-CE-A	Network Management - Connection Establishment-A	□	Establish-Connection-To-Network	x	
			Disconnect-Connection-To-Network	x	
NM-CE-B	Network Management - Connection Establishment-B	□	Establish-Connection-To-Network		x
			Disconnect-Connection-To-Network		x
DM-BR-A	Network Management - Router Configuration-A	□	Who-Is-Router-To-Network	x	
			I-Am-Router-To-Network		x
			I-Could-Be-Router-To-Network		x
			Initialize-Routing-Table	x	
			Initialize-Routing-Table-Ack		x
NM-RC-B	Network Management - Router Configuration-B	□	Who-Is-Router-To-Network	x	x
			I-Am-Router-To-Network	x	x
			Initialize-Routing-Table		x
			Initialize-Routing-Table-Ack	x	

Multi - state Input Object Type

Property Identifier	Property Datatype	ACP BACnet	BNU-BAC
Object_Identifier	BACnetObjectIdentifier	R	R
Object_Name	CharacterString	R	R
Object_Type	BACnetObjectType	R	R
Present_Value	Unsigned	R1	R
Description	CharacterString	O	R
Device_Type	CharacterString	O	-
Status_Flags	BACnetStatusFlags	R	R
Event_State	BACnetEventState	R	R
Reliability	BACnetReliability	O2	-
Out_Of_Service	Boolean	R	R
Number_Of_States	Unsigned	R	R
State_Text	BACnetARRAY[N] of CharacterString	O	-
Time_Delay	Unsigned	O3	-
Notification_Class	Unsigned	O3	-
Alarm_Values	List of Unsigned	O3	-
Fault_Values	List of Unsigned	O3	-
Event_Enable	BACnetEventTransitionBits	O3	-
Acked_Transitions	BACnetEventTransitionBits	O3	-
Notify_Type	BACnetNotifyType	O3	-
Event_Time_Stamps	BACnetARRAY[3] of BACnet-TimeStamp	O3	-

Multi - state Output Object Type

Property Identifier	Property Datatype	ACP BACnet	BNU-BAC
Object_Identifier	BACnetObjectIdentifier	R	R
Object_Name	CharacterString	R	R
Object_Type	BACnetObjectType	R	R
Present_Value	Unsigned	W	W
Description	CharacterString	O	R

Property Identifier	Property Datatype	ACP BACnet	BNU-BAC
Device_Type	CharacterString	O	-
Status_Flags	BACnetStatusFlags	R	R
Event_State	BACnetEventState	R	R
Reliability	BACnetReliability	O	-
Out_Of_Service	Boolean	R	R
Number_Of_States	Unsigned	R	R
State_Text	BACnetARRAY[N] of CharacterString	O	-
Priority_Array	BACnetPriorityArray	R	-
Relinquish_Default	Unsigned	R	-
Time_Delay	Unsigned	O1	-
Notification_Class	Unsigned	O1	-
Feedback_Value	Unsigned	O1	-
Event_Enable	BACnetEventTransitionBits	O1	-
Acked_Transitions	BACnetEventTransitionBits	O1	-
Notify_Type	BACnetNotifyType	O1	-
Event_Time_Stamps	BACnetARRAY[3] of BACnet-TimeStamp	O1	-
Profile_Name	CharacterString	O	-

ACP-BACnet Error Response Table

Error PDU

Error PDU	Error Class	Error Code
Reading of the object list during the initialization of the LG-NET	Device(0)	Configuration_In_Progress(2)
Request to access to an object not installed.	Object(1)	Unknown_Object(31)
Request to access to a property not installed.	Property(2)	Unknown_Property(32)
Request to write to a prohibited area.	Property(2)	Write_Access_Denied(40)
Request to write in a format different from the property.	Property(2)	Invalid_Datatype(9)
Request to access to a specified index outside the array index range.	Property(2)	Invalid_Array_Index(42)
Request to write a value outside the permissible range.	Property(2)	Value_Out_Of_Range(37)
A COV registration request of more than 10 registration items.	Resource(3)	Other(0)
An Event registration request of more than 10 registration items.	Resource(3)	No_Space_To_Add_List_Element(19)
Request for the deletion of an element not existing in the list.	Service(5)	Other(0)
Request for the execution of the AddListElement/ RemoveListElement for a property that is not of List type.	Service(5)	Property_Is_Not_List(22)

Reject PDU

Reject PDU	Reject Reason
A propertyID or value overflow or underflow occurred during WritePropertyMultiple operation.	Inconsistent_Parameter(2)
The type of parameter for the execution of the service is different in type.	Invalid_Parameter_Data_Type(3)
An error was detected during tag decoding.	Invalid_Tag(4)
A parameter shortage occurred during the execution of the service.	Missing_Required_Parameter(5)
Too many arguments for the execution of the service.	Too_Many_Arguments(7)
An attempt to execute an unsupported service with confirmation.	Unrecognized_Service(9)

Abort PDU

Reject PDU	Reject Reason
Unable to process due to too many requests beyond the capacity.	Buffer_Overflow(1)
The processing of segments was aborted because an expected APDU was received.	Invalid_APDU_In_This_State(2)
The response side does not support the segment.	Segmentation_Not_Supported(4)

Class A device**Notes**

This equipment has been tested and found to comply with the limits for a Class A digital device, pursuant to part 15 of the FCC Rules.

These limits are designed to provide reasonable protection against harmful interference when the equipment is operated in a commercial environment.

This equipment generates, uses, and can radiate radio frequency energy and, if not installed and used in accordance with the instruction manual, may cause harmful interference to radio communications. Operation of this equipment in a residential area is likely to cause harmful interference in which case the user will be required to correct the interference at his own expense.

**Caution**

Changes or modifications not expressly approved by the manufacturer responsible for compliance could void the user's authority to operate the equipment.

**Disposal of your old appliance**

1. When this crossed-out wheeled bin symbol is attached to a product it means the product is covered by the European Directive 2002/96/EC.
2. All electrical and electronic products should be disposed of separately from the municipal waste stream via designated collection facilities appointed by the government or the local authorities.
3. The correct disposal of your old appliance will help prevent potential negative consequences for the environment and human health.
4. For more detailed information about disposal of your old appliance, please contact your city office, waste disposal service or the shop where you purchased the product.

