



MULTI F

MULTI F MAX

INDOOR UNIT ENGINEERING MANUAL



Art Cool™ Mirror Wall-Mounted



Art Cool™ Gallery Wall-Mounted



Four-Way Ceiling Cassette



Ceiling-Concealed Duct (High Static)

Indoor Units for Multi-Zone Heat Pump Systems
7,000 to 36,000 Btu/h





PROPRIETARY DATA NOTICE

This document, as well as all reports, illustrations, data, information, and other materials are the property of LG Electronics U.S.A., Inc., and are disclosed by LG Electronics U.S.A., Inc., only in confidence.
This document is for design purposes only.

EM-MultiFIDU-01-15

For continual product development, LG reserves the right to change specifications without notice.
©LG Electronics Inc.

TABLE OF SYMBOLS

 DANGER	<i>This symbol indicates an imminently hazardous situation which, if not avoided, will result in death or serious injury.</i>
 WARNING	<i>This symbol indicates a potentially hazardous situation which, if not avoided, could result in death or serious injury.</i>
 CAUTION	<i>This symbol indicates a potentially hazardous situation which, if not avoided, may result in minor or moderate injury.</i>
Note:	<i>This symbol Indicates situations that may result in equipment or property damage accidents only.</i>
	<i>This symbol indicates an action that should not be performed.</i>

This document, as well as all reports, illustrations, data, information, and other materials are the property of LG Electronics U.S.A., Inc.

MULTI F MULTI F MAX

TABLE OF CONTENTS

Convergence of Technology, Innovation, Flexibility, & Style	4
Unit Nomenclature	6
Outdoor Unit Overview	7
Indoor Unit Overview	8
Controls and Options Overview	9
Art Cool Mirror Indoor Units	16
<i>Mechanical Specifications and Features</i>	16
<i>General Data / Specifications</i>	17
<i>Dimensions</i>	18
<i>Cooling Capacity Table</i>	20
<i>Heating Capacity Table</i>	22
<i>Acoustic Data</i>	23
<i>Air Velocity and Temperature Distribution</i>	25
<i>Refrigerant Flow Diagram</i>	26
<i>Wiring Diagram</i>	27
<i>Factory Supplied Parts and Materials</i>	29
<i>Installation and Best Layout Practices</i>	30
Art Cool Gallery Indoor Units	38
<i>Mechanical Specifications and Features</i>	38
<i>General Data / Specifications</i>	39
<i>Dimensions</i>	40
<i>Cooling Capacity Table</i>	41
<i>Heating Capacity Table</i>	42
<i>Acoustic Data</i>	43
<i>Air Velocity and Temperature Distribution</i>	44
<i>Refrigerant Flow Diagram</i>	45
<i>Wiring Diagram</i>	46
<i>Factory Supplied Parts and Materials</i>	47
<i>Installation and Best Layout Practices</i>	48
Standard Wall-Mounted Indoor Units	58
<i>Mechanical Specifications and Features</i>	58
<i>General Data / Specifications</i>	59
<i>Dimensions</i>	60
<i>Cooling Capacity Table</i>	64
<i>Heating Capacity Table</i>	67
<i>Acoustic Data</i>	69
<i>Air Velocity and Temperature Distribution</i>	71
<i>Refrigerant Flow Diagram</i>	74
<i>Wiring Diagram</i>	75
<i>Factory Supplied Parts and Materials</i>	79
<i>Installation and Best Layout Practices</i>	80
Duct (Low Static) Indoor Units	90
<i>Mechanical Specifications and Features</i>	90
<i>General Data / Specifications</i>	91
<i>Dimensions</i>	92
<i>Cooling Capacity Table</i>	93
<i>Heating Capacity Table</i>	95
<i>External Static Pressure</i>	96
<i>Acoustic Data</i>	97
<i>Refrigerant Flow Diagrams</i>	98
<i>Wiring Diagram</i>	100
<i>Factory Supplied Parts and Materials</i>	101
<i>Installation and Best Layout Practices</i>	102

Duct (High Static) Indoor Units	112
<i>Mechanical Specifications and Features</i>	112
<i>General Data / Specifications</i>	113
<i>Dimensions</i>	114
<i>Cooling Capacity Table</i>	115
<i>Heating Capacity Table</i>	116
<i>External Static Pressure / Acoustic Data</i>	117
<i>Refrigerant Flow Diagrams</i>	118
<i>Wiring Diagrams</i>	119
<i>Factory Supplied Parts and Materials / Installation</i>	120
<i>Installation and Best Layout Practices</i>	121
Four-Way Ceiling Cassette Indoor Units	130
<i>Mechanical Specifications and Features</i>	130
<i>General Data / Specifications</i>	131
<i>Dimensions</i>	132
<i>Dimensions</i>	133
<i>Cooling Capacity Table</i>	134
<i>Heating Capacity Table</i>	136
<i>Acoustic Data</i>	138
<i>Air Velocity and Temperature Distribution</i>	140
<i>Refrigerant Flow Diagram</i>	142
<i>Wiring Diagram</i>	143
<i>Factory Supplied Parts and Materials</i>	144
<i>Installation and Best Layout Practices</i>	145
Vertical-Horizontal Indoor Units	154
<i>Mechanical Specifications and Features</i>	154
<i>General Data / Specifications</i>	155
<i>Dimensions</i>	156
<i>Cooling Capacity Table</i>	157
<i>Heating Capacity Table</i>	158
<i>External Static Pressure</i>	159
<i>Acoustic Data</i>	160
<i>Refrigerant Flow Diagram</i>	161
<i>Wiring Diagram</i>	162
<i>Factory Supplied Parts and Materials</i>	164
<i>Installation and Best Layout Practices</i>	165
Application Guidelines	174
<i>Equipment Selection Procedure</i>	174
<i>Building Ventilation Design Guide</i>	180
<i>Placement Considerations</i>	185
Refrigerant Piping Design	192
<i>Design Guideline Summary</i>	192
<i>Design Guideline Summary</i>	193
<i>Creating a Balanced System / Manual Layout Procedure</i>	194
<i>LG Engineered Multi F MAX Y-Branch Kit</i>	195
<i>Refrigerant Charge</i>	196
Installation & Layout Best Practices	199
<i>Selecting Field-Supplied Copper Tubing</i>	199
<i>Refrigerant Piping System Layout</i>	200
<i>Piping Insulation</i>	208
<i>Condensate Drain Piping</i>	209
<i>Y-Branch Kit</i>	211
Wiring Connections	214
<i>General Information</i>	214
<i>Power Wiring (208-230V) and Communications Cable Details</i>	217
<i>Indoor Unit Group Control</i>	222
Acronyms	223

CONVERGENCE OF TECHNOLOGY, INNOVATION, FLEXIBILITY, & STYLE



About LG Electronics, Inc.

LG Electronics, Inc. is a global leader and technology innovator in consumer electronics, mobile communications, and home appliances, employing more than 213,000 people in more than 60 countries worldwide. LG Electronics, Inc. comprises five business units—Home Entertainment, Mobile Communications, Air Conditioning, Business Solutions, and Home Appliance. LG is one of the world's leading producers of flat panel televisions, audio and video products, mobile handsets, air conditioners, and washing machines. LG's commercial air conditioning business unit was established in 1968 and has built its lineup of residential and commercial products to include VRF, Multi F, duct-free split systems, packaged terminal air conditioners (PTACs), and room air conditioners. In 2011, the air conditioning and energy solutions business unit grew to include LED lighting and solar products. For more information, visit www.lg-dfs.com.

Multi-Zone Systems

LG HVAC systems offer a range of solutions that are cost efficient, quiet and attractive. Multi-zone systems are "split" into indoor and outdoor units, and provide a smart alternative to both central HVAC and window-mounted air conditioners. These inverter heat pump systems are available in a variety of configurations to suit different cooling and heating situations. Installation by a qualified HVAC contractor is safe and easy – little to no duct work or sheet metal is required.

Benefits of Multi F Systems

- Individual zone control
- Long refrigerant piping lengths
- High refrigerant piping elevation differences
- Maximum flexibility
- Operating ranges of 14°F to 118°F (DB) in cooling and -4°F to 64°F (WB) in heating
- Quiet and comfortable environment
- Reduced ductwork



Multi F Systems

LG's inverter heat pumps can support two, three, or four indoor units that are typically installed in separate rooms. Each indoor unit includes its own remote control, allowing the customer to set the temperature individually. Indoor units are available in several different configurations: Art Cool™ Mirror wall-mounted, Art Cool Gallery wall-mounted, standard wall-mounted, four-way ceiling cassettes, ceiling-concealed duct (high and low static), and vertical-horizontal air handling models. Multi F MAX systems, released in 2012, can operate up to eight indoor units through two-, three-, or four-port branch distribution units.

Adaptable and Flexible

Multi F outdoor units can be adapted to a wide range of building applications and sizes such as schools, hotels, hospitals, offices, and residences. The system components are lightweight and compact so they can be placed in buildings without expensive cranes, they easily fit into most service elevators, and they can be set in place with minimal structural reinforcements requirements.

Multi F technology allows you to pipe farther by reaching areas of the building that would require the installation of a second system when using traditional direct-expansion cooling and heating equipment. Multi F provides the designer with uncompromised pipe system engineering flexibility—long pipe runs and large elevation differences. Whether your building is a condominium, a hotel, a school, or an office complex, Multi F is best suited to reach the farthest corners and elevations.

Smaller Chases and Plenums

LG Multi F systems use refrigerant piping to move heat, resulting in smaller space requirements for piping as compared to chilled water or roof top systems. This helps reduce the overall construction and material cost of the building, and gives back leasable space. Flexible and logical placement of system components, reduced back-and-forth pipe lengths, and fewer joints lowers installation costs and minimizes potential leaking.

Quality Commitment

LG is committed to the success of DFS projects. We provide technical support during installation and commissioning. LG offers a variety of classes designed for installers and servicers on Multi F installation. Classes are conducted at LG's training centers and in field locations at various times throughout the year and upon special request.



MULTI F



PRODUCT INTRODUCTION

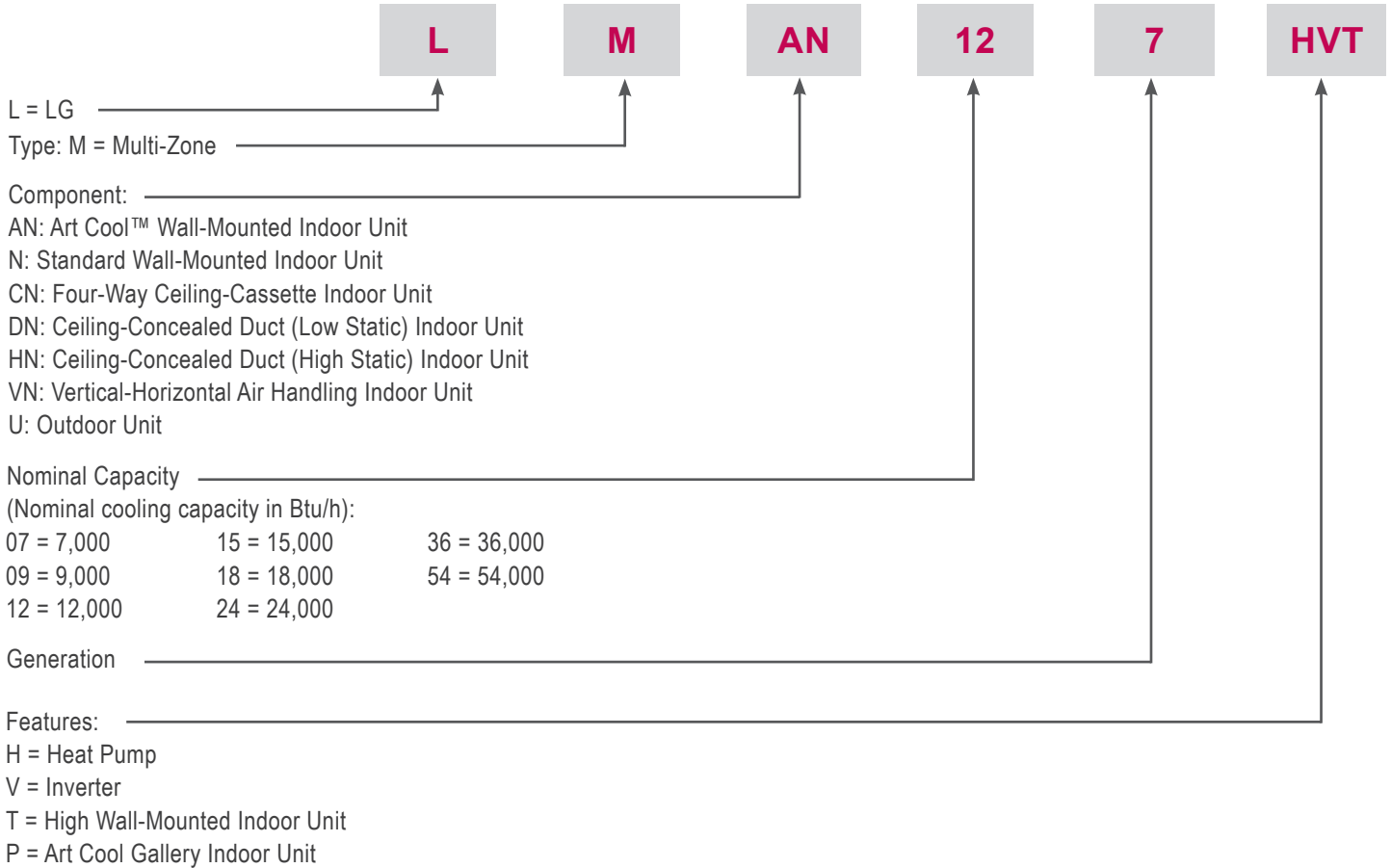
“Unit Nomenclature” on page 6

“Outdoor Unit Overview” on page 7

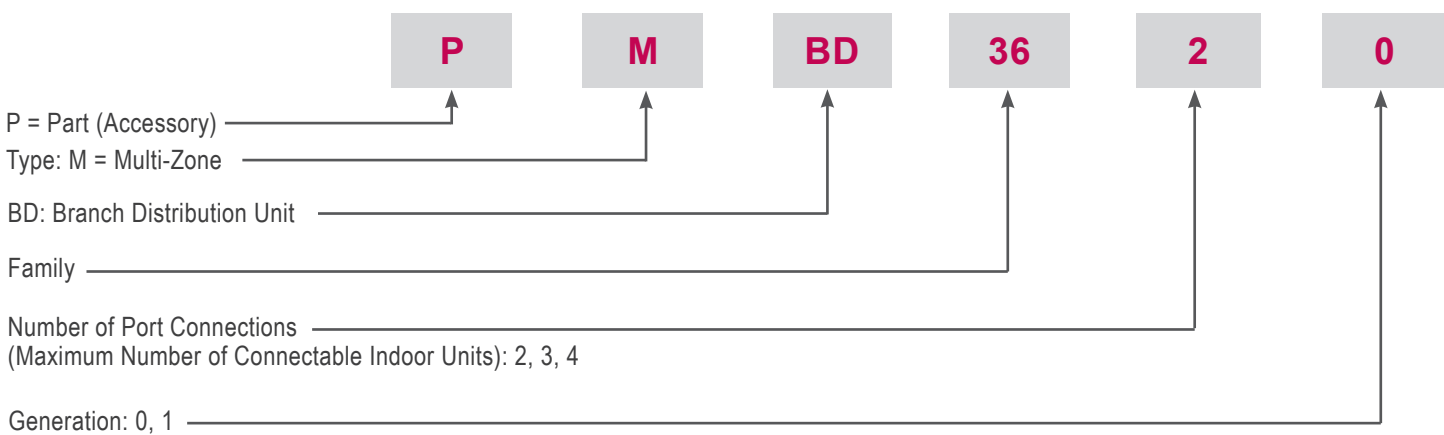
“Indoor Unit Overview” on page 8

“Controls and Options Overview” on page 9

Multi-Zone Systems — Indoor Units and Outdoor Units







Branch Distribution Units



Note:

- Voltage for all equipment is 208-230V, 60 Hz, 1-phase.
- All indoor units are compatible with wired controllers
- All outdoor units are LGAP control network compatible with PI-485 V-net Control Integration Board (PMNFP14A1, sold separately).
- Compatible single zone IDU nomenclature is listed in the Single Zone Wall-Mounted IDU Engineering Manual.

Table 1: Summary Data—Multi F / Multi F MAX Outdoor Units

Outdoor Unit Type	Model Number ¹	Dimensions (W x H x D) (inches)	Nominal Cooling Capacity Btu/h ²	Net Weight (lbs.)	No. of Connectable Indoor Units ³	Pipe Connections (inches, O.D.) (Liquid, Vapor)
Multi F Dual-Zone 	LMU18CHV	34-1/4 x 25 25/32 x 12-19/32	18,000	99	2-2	1/4 x 2 Each, 3/8 x 2 Each
Multi F Tri-Zone 	LMU24CHV	34-1/4 x 25 25/32 x 12-19/32	24,000	99	2-3	1/4 x 3 Each, 3/8 x 3 Each
Multi F Quad-Zone 	LMU36CHV	37-13/32 x 32-27/32 x 13	36,000	137	2-4	1/4 x 4 Each, 3/8 x 4 Each
Multi F MAX Eight-Zone 	LMU540HV	37-13/32 x 54-11/32 x 13	54,000	214	2-8	3/8 x 1 Each, 3/4 x 1 Each

¹Model number shows nominal capacity and frame size designator.

²Nominal capacity rating obtained with air entering the indoor unit at 80°F dry bulb (DB) and 67°F wet bulb (WB) and outdoor ambient conditions of 95°F dry bulb (DB) and 75°F wet bulb (WB).

³Minimum number of connectable indoor units is two (2).

INDOOR UNIT OVERVIEW

MULTI F
MULTI F MAX

Table 2: Summary Data—Multi F Indoor Units.






Indoor Unit Type	Model Number ¹	Dimensions (W x H x D) (inches)	Nominal Cooling Capacity Btu/h ²	Air Flow Rate (CFM) (H/M/L ³)	Net Weight (lbs.)	Pipe Connections (inches, O.D.) (Liquid, Vapor)
Art Cool™ Mirror Wall-Mounted 	LMAN097HVT	35-1/4 x 11-3/8 x 8-1/16	9,000	247 / 230 / 212	25	1/4, 3/8
	LMAN127HVT		12,000	335 / 318 / 300		
	LMAN187HVT	40-9/16 x 12-25/32 x 9-21/32	18,000	572 / 501 / 434	35	1/4, 1/2
Art Cool™ Gallery Wall-Mounted 	LMAN097HVP	23-5/8 x 23-5/8 x 5-25/32	9,000	272 / 208 / 155	32	1/4, 3/8
	LMAN127HVP		11,200	314 / 258 / 198		
Standard Wall-Mounted 	LMN077HVT	35-1/4 x 11-3/8 x 8-9/32	7,000	198 / 177 / 162	23	1/4, 3/8
	LSN090HSV4	34-7/8 x 11-1/4 x 8-1/4	9,000	247 / 230 / 212	20	1/4, 3/8
	LSN120HSV4	34-7/8 x 11-1/4 x 8-1/4	12,000	335 / 318 / 300	20	1/4, 3/8
	LMN157HVT	35-1/4 x 11-3/8 x 8-9/32	14,300	371 / 318 / 247	23	1/4, 3/8
	LSN180HSV4	40-9/16 x 12-13/16 x 9-13/16	18,000	572 / 501 / 434	31	3/8, 5/8
	LMN247HVT	40-9/16 x 12-25/32 x 9-27/32	24,000	720 / 600 / 466	32	1/4, 1/2
Ceiling-Concealed Duct (Low Static) 	LMDN096HV	27-9/16 x 7-15/32 x 27-9/16	9,000	318 / 247 / 194	39	1/4, 3/8
	LMDN126HV	35-7/16 x 7-15/32 x 27-9/16	12,000	353 / 300 / 247		
	LMDN186HV		18,000	530 / 441 / 353	51	1/4, 1/2
Ceiling-Concealed Duct (High Static) 	LMHN240HV	46-17/32 x 11-23/32 x 17-23/32	24,000	688 / 618 / 530	80	1/4, 1/2
	LMHN360HV		36,000	1,130 / 953 / 706	91	3/8, 5/8
Four-Way Ceiling-Cassette 	LMCN077HV	Body: 22-7/16 x 8-7/16 x 22-7/16 Panel: 27-9/16 x 7/8 x 27-9/16	7,000	265 / 212 / 177	31 (Body), 7 (Panel)	1/4, 3/8
	LMCN097HV		9,000	300 / 265 / 230		
	LMCN125HV		12,000	335 / 283 / 247		
	LMCN185HV	Body: 22-7/16 x 10-3/32 x 22-7/16 Panel: 27-9/16 x 7/8 x 27-9/16	18,000	459 / 424 / 388	34 (Body), 7 (Panel)	1/4, 1/2
Vertical-Horizontal Air Handling 	LMVN240HV	18 x 48-21/32 x 21-1/4	24,000	710 / 640 / 480	117	1/4, 1/2
	LMVN360HV		36,000	990 / 880 / 800	121	3/8, 5/8

¹Model number shows nominal capacity and frame size designator.

²Nominal capacity rating obtained with air entering the indoor unit at 80°F dry bulb (DB) and 67°F wet bulb (WB) and outdoor ambient conditions of 95°F dry bulb (DB) and 75°F wet bulb (WB).

³H/M/L = High/Medium/Low.

Table 3: Summary Data—Zone Controllers.

Zone Controller	Name	Model / Part No.	Case Color	Max. Wire Length (ft.)	Description
	Simple Controller with Mode Selection	PQRCVCL0	Black	164	Allows control of indoor unit ON / OFF, operation mode, fan speed, and temperature setpoint for up to 16 indoor units. Included with Ceiling-Concealed Duct (High Static and Low Static ¹) and Vertical-Horizontal Air Handling ¹ indoor units; optional accessory for all other indoor unit types.
		AKB72955816 ¹	White		
	Simple Controller without Mode Selection	PQRCHCA0	Black	164	Allows control of indoor unit ON / OFF, fan speed, and temperature setpoint for up to 16 indoor units.
		PQRCHCA0QW	White		
	LG 7-Day Programmable Thermostat	PREMTB10U	White	164	Allows control of indoor unit ON / OFF, operation mode, occupied / unoccupied temperature setpoints, fan speed, and airflow direction for up to 16 indoor units. Programmable schedule with five events per day.
	Wireless Controller	AKB73635606 ³ AKB73635607 ⁴ AKB73835312 ⁵ AKB73757604 ⁶	Ivory	-	Allows control of indoor unit ON / OFF, operation mode, fan speed, and temperature setpoint. Also provides subfunction control. Included with Art Cool Mirror ³ and Gallery ⁴ Wall-Mounted, Standard HVT ³ Wall-Mounted, Standard HSV ⁵ Wall-Mounted, and Four-Way Cassette ⁶ indoor units; optional accessory for Duct and Vertical-Horizontal AHU with use of wired controller.
	Wall-Mounted Remote Temperature Sensor	PQRSTA0	Ivory	50	Allows remote temperature measurement for four-way ceiling cassette, ceiling-concealed duct, and vertical-horizontal air handling indoor units.

¹Simple Mode Controllers for the ceiling-concealed duct (high static and low static) and the vertical-horizontal air handling indoor units are also referenced by Model No. PQRCVCL0QW.

Before specifying or placing an order, refer to the V-Net Network Solutions Engineering Product Data Book, and review the detailed technical data provided to fully understand the capabilities and limitations of these devices.

For information on controller capability, refer to the Controls and Options Table on page 12

Table 4: Summary Data—Controller Accessories.




Controller Accessory	Name	Model No.	Description	For
	Auxiliary Heater Relay Kit	PRARH0	Adds coordinated control of an external heater with normal heat pump operations. Contact energizes at 2.7°F below setpoint. De-energizes at 2.7°F above setpoint.	Ceiling-concealed duct (high static and low static) and four-way ceiling cassette indoor units.
		PRARS0		Standard and Art Cool Mirror wall-mounted indoor units.




Table 5: Summary Data— Zone Controller Communication Cables.

Communication Cable	Name	Model No.	Max. Wire Length (ft.)	Description
	Wired Remote Group Control Cable Assembly	PZCWRCG3	32	Required when grouping multiple indoor units with a single zone controller.
	Wired Remote / Group Control Extension Cable	PZCWRC1	32	Increases the distance between a remote controller and an indoor unit, or between indoor units in a control group.

Before specifying or placing an order, refer to the V-Net Network Solutions Engineering Product Data Book, and review the detailed technical data provided to fully understand the capabilities and limitations of these devices.

For information on controller capabilities, refer to the Controls and Options Table on page 12.




Table 6: Summary Data—Specialty Application Devices.

Specialty Application Device	Name	Model No.	Connects to	Application	Binary Signals Input / Output	Description
	Dry Contact Unit 24 VAC	PQDSB1	Indoor Unit	ON / OFF, Run Status, Error Status	1 / 2	Enables the indoor unit to be controlled and monitored by third-party controls using binary inputs and outputs.
	Dry Contact Unit for Setback	PQDSBC		ON / OFF, Mode, Controller Lock, Power Save, Run Status, Error Status	2 / 2	
	Dry Contact Unit for Thermostat	PQDSBNGCM1		ON / OFF, Thermo ON / OFF, Mode, Fan Speed, Run Status, Error Status	—	Enables the indoor unit to be controlled and monitored by a third-party thermostat or controller.
	PI-485 V-net Control Integration Board	PMNFP14A1	Outdoor Unit	—	—	Control integration to LG V-net controls (AC Smart Premium, ACP, BACnet, LonWorks, etc.)
	Power Distribution Indicator (PDI) Premium	PQNUD1S41	Comm. BUS	Energy Consumption Monitoring	8 / 0	Monitors total outdoor unit power consumption for up to eight systems, and distributes per indoor unit based on weighted calculation.

Before specifying or placing an order, refer to the V-Net Network Solutions Engineering Product Data Book, and review the detailed technical data provided to fully understand the capabilities and limitations of these devices.

For information on controller capabilities, refer to the Controls and Options Table on page 12.



Table 7: Summary Data—Central Controllers (Connect to the Outdoor Unit Through the PI-485 Board (accessory, sold separately)).

Central Controller	Name	Model No.	Devices per Controller	Systems per Comm. BUS	Devices per Comm. BUS	No. of Comm. BUS ports	Binary Signals Input / Output	Power / Connection	Description
	AC Smart Premium	PQCSW421E0A	128	16	128	1	2 DI / 2 DO	24 VAC	Provides for scheduling, auto-changeover, setback, remote controller lock, setpoint range limit, run time limit, web access, email alarm notification, visual floorplan navigation, peak/demand control, software device interlocking, PDI integration, and AC Manager Plus integration advanced functionality in addition to basic unit control and monitoring.
	AC Ez	PQCSZ250S0	32	16	256	1	—	12 VDC / Outdoor Unit	Provides for scheduling in addition to basic indoor unit control and monitoring.
	Advanced Control Platform (ACP) Standard	PQCPC22N1	256	16	64 (128 with PDI Premium)	4	2 / 2	24 VAC	Provides for scheduling, remote controller lock, setpoint range limit, web access, peak / demand control, PDI integration, and AC Manager Plus integration advanced functionality in addition to basic unit control and monitoring.
	Advanced Control Platform (ACP) Premium	PQCPC22A1	256	16	64 (128 with PDI Premium)		10 / 4	24 VAC	

Before specifying or placing an order, refer to the V-Net Network Solutions Engineering Product Data Book, and review the detailed technical data provided to fully understand the capabilities and limitations of these devices.

For information on controller capabilities, refer to the Controls and Options Table on page 12.

Table 8: Summary Data—Integration Solutions (Connect to Outdoor Unit Through the PI-485 Board (accessory, sold separately)).

Central Controller	Name	Model No.	Devices per Controller	Systems per Comm. BUS	Devices per Comm. BUS	No. of Comm. BUS ports	Binary Signals Input / Output	Power / Connection	Description
	BACnet® Gateway	PQNFB17C1	256	16	64 (128 with PDI Premium)	4	2 / 2	24 VAC	Allow integration of LG equipment for control and monitoring by open protocol BACnet and LonWorks building automation and controls systems.
	LonWorks® Gateway	PLNWKB100	64	16	64 (128 with PDI Premium)	1	2 / 2	24 VAC	

Before specifying or placing an order, refer to the V-Net Network Solutions Engineering Product Data Book, and review the detailed technical data provided to fully understand the capabilities and limitations of these devices.

For information on controller capabilities, refer to the Controls and Options Table on page 12.

CONTROLS AND OPTIONS OVERVIEW

MULTI F
MULTI F MAX

Multi F and Multi F MAX Indoor Unit Engineering Manual

Table 9: Indoor Units—Functions, Controls and Options.

Indoor Unit Type		ART COOL™ Mirror Wall Mounted	ART COOL™ Gallery	Standard Wall Mounted	Ceiling Concealed (Low Static) Ducted	Ceiling Concealed (High Static) Ducted	Four-Way Ceiling Cassette	Vertical- Horizontal Air Handling Unit
Airflow	Air supply outlets	1	3	1	1	2	4	1
	Airflow direction (left/right)	Auto	Auto	Auto				
	Airflow direction (up/down)	Auto	Auto	Auto			Auto	
	Auto swing (left/right)	√	√	√				
	Auto swing (up/down)	√	√	√			√	
	Airflow steps (fan/cool/heat)	6 / 6 / 5	5 / 5 / 4	6 / 6 / 5	3 / 3 / 3	3 / 3 / 3	4 / 5 / 4	3 / 3 / 3
	Chaos wind (random fan speed)	√	√	√			√	
	Jet-cool	√	√	√			√	
	Swirl wind						√	
Filter	Washable anti-fungal ¹	√	√	√	√	√	√	
	Plasma ²	√		√			o ³	
	3M HAF ²			√				
	Ventilation						√ ⁴	
Operation	Drain pump				√	√	√	
	E.S.P. control				√	√		√
	Electric heater							o
	High ceiling						√	
	Hot Start	√	√	√	√	√	√	√
	Self diagnostics	√	√	√	√	√	√	√
	Soft Dry (dehumidification)	√	√	√	√	√	√	√
	Auto operation	√	√	√	√	√	√	√
	Auto clean (coil dry)	√	√	√				
	Auto restart	√	√	√	√	√	√	√
	Child lock	o	o	o	o	o	o	o
	Forced operation	√	√	√			√	
	Group control – Requires the use of one Group control Cable Kit (PZCWRG3) for every additional indoor unit	o	o	o	o	o	o	o
	Sleep mode	√	√	√	√	√	√	√
	Timer (on/off)	√	√	√	√	√	√	√
	Weekly schedule	o	o	o	√	√	o	√
Two thermistor control	o	o	o	o	o	o	o	
Controllers	7-Day programmable controller	o	o	o	o	o	o	o
	Simple wired remote controller	o	o	o	√	√	o	√
	Wireless LCD remote control	√	√	√	o ⁵	o ⁵	√	o ⁵
	Dry contact	o	o	o	o	o	o	o
	Dry contact (temperature setting)	o	o	o	o	o	o	o
	Central control (LGAP)	√	√	√	√	√	√	√
	Connector for Water Sensor	√	√	√				

¹Primary washable filters.

²Secondary filter (plasma: HVT wall-mount and cassette; 3M: HSV4)

³Branch location and static pressure requirements. Requires PTPKQ0 Plasma kit.

⁴Requires ventilation kit PTVK430 (Temperature, humidity, and volume limitations apply).

⁵Requires wired zone controller.

√ = Standard feature

o = Unit option

Table 10: Multi F MAX Outdoor Unit Accessories Overview.




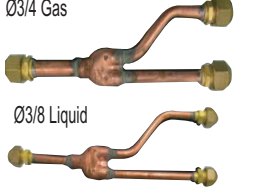
Multi F MAX Accessory	Name	Model No.	Description
	Two-Port Branch Distribution Unit	PMBD3620	Distributes refrigerant from Multi F MAX outdoor unit from one (1) to two (2) indoor units (maximum 24,000 Btu/h for each port).
	Three-Port Branch Distribution Unit	PMBD3630	Distributes refrigerant from Multi F MAX outdoor unit from one (1) to three (3) indoor units (maximum 24,000 Btu/h for each port).
	Four-Port Branch Distribution Unit	PMBD3640	Distributes refrigerant from Multi F MAX outdoor unit from one (1) to four (4) indoor units (maximum 24,000 Btu/h for each port).
		PMBD3641	Distributes refrigerant from Multi F MAX outdoor unit from one (1) to four (4) indoor units (maximum 24,000 Btu/h for ports A,B,C; maximum 36,000 Btu/h for D port).
	Y-branch Kit	PMBL5620	Y-branch Kit for Multi F MAX outdoor unit to connect up to two (2) branch distribution units.

Table 11: Indoor Unit Accessories Overview.

Model No.	Description
<i>For Four-Way Ceiling-Cassette Indoor Units</i>	
PT-UQC	Ceiling Grille
PTPKQ0	Plasma Kit
PTVK430	Ventilation Kit
<i>For Vertical-Horizontal Air Handling Units</i>	
ANEH053B1	5 kW Electric Heater
ANEH103B2	10 kW Electric Heater
<i>For Ceiling-Concealed Duct (High Static) Indoor Units</i>	
ZFBXBG01A	High Efficiency Filter Box
ZFBXD201A	Dynamic V8 2VL Low Profile Air Cleaner
ZPLMV201A	Dynamic 2VL Air Cleaner Low Profile Return Air Plenum
ZFBXD402A	Dynamic V8 4VL Low Profile Air Cleaner
ZPLMV402A	Dynamic 4VL Air Cleaner Low Profile Return Air Plenum
ZFLT1301A	4-Pack Dynamic V8 VL Air Cleaner Replacement Filter Pads
ZFLT1302A	24-Pack Dynamic V8 VL Air Cleaner Replacement Filter Pads
ZGRLRA01A	Dynamic V8 Air Cleaner Louvered Return Air Grille (one per plenum)
ZGRLRA02A	Dynamic V8 Air Cleaner Egg Crate Return Air Grille (one per plenum)

ART COOL™ MIRROR INDOOR UNIT DATA

- “Mechanical Specifications” on page 16**
- “General Data / Specifications” on page 17**
- “Dimensions” on page 18**
- “Cooling Capacity Table” on page 20**
- “Heating Capacity Table” on page 22**
- “Acoustic Data” on page 23**
- “Air Velocity and Temperature Distribution” on page 24**
- “Refrigerant Flow Diagram” on page 26**
- “Wiring Diagram” on page 27**
- “Factory Supplied Parts and Materials” on page 29**
- “Installation and Best Layout Practices” on page 30**

ART COOL MIRROR INDOOR UNITS

Mechanical Specifications and Features

MULTI F
MULTI F MAX

ART COOL Mirror Wall-Mounted Indoor Units

General

All LG indoor units are factory assembled, wired, piped, and provided with a control circuit board, fan, and motor. ART COOL Mirror Wall-Mounted indoor units have a sound rating no higher than 39 dB(A) as tested per KSA0701 ISO Standard 3745.

Coil

Indoor unit coils are comprised of a minimum of two rows of aluminum fins mechanically bonded to copper tubing. The coils are pressure tested at the factory. Each unit is provided with a factory installed condensate drain pan below the coil.

Refrigerant System

System is designed for use with R410A refrigerant. The refrigeration circuit is pressure-tested at the factory and shipped with a holding charge of helium gas. Refrigerant pipe connections are 45° flare. All refrigerant lines from the outdoor unit to the indoor units must be field insulated.

Electrical

Each indoor unit is designed to operate using 208–230/60/1 power with voltage variances of ±10%.

Casing

Units are designed to mount on a vertical surface, and are shipped with a separate back plate that secures the unit to the wall, protruding no more than ten (10) inches. Unit is designed so that refrigerant piping can be installed in one (1) of four (4) different directions.

Finish

The Art Cool Mirror unit has a flat, architectural panel with a smoked charcoal mirror finish. Unit casing has a dark grey finish and is manufactured of heavy-duty acrylonitrile butadiene styrene (ABS) and high impact polystyrene (HIPS) plastic.

Fan Assembly and Control

The unit has a single, direct-drive, crossflow fan made of high strength ABS plastic. The fan motor is brushless digitally controlled (BLDC) with permanently lubricated and sealed ball bearings. The fan / motor assembly is mounted on vibration attenuating rubber grommets. Fan speed is controlled using a microprocessor-based direct digitally controlled algorithm that provides pre-programmed, field-selectable fixed or auto fan speeds in the Heating and Cooling modes. For Art Cool Mirror Wall-Mounted units, the indoor fan has Low, Med, High, Power Cool and Auto settings for Cooling mode; and has Low, Med, High, and Auto settings for Heating mode. The Auto setting adjusts the fan speed based on the difference between the controller setpoint and space temperature. Also, the separate Chaos

Features

- Inverter (Variable speed fan)
- Chaos swing
- Plasma filter
- Jet cool
- Group Control
- Self-cleaning indoor coil
- Auto operation
- Auto restart operation
- Dehumidifying function
- Self diagnosis function
- Wireless LCD remote control included; wired thermostat available (sold separately)

Figure 1: Multi F Art Cool Mirror Wall-Mounted Indoor Unit.



setting provides a simultaneous and random change in fan speed and flow direction at the discharge, simulating a natural outdoor breeze.

Air Filter

Return air inlet has a factory-supplied primary removable, washable filter. The unit is also equipped with a secondary plasma filter. Filters are accessed from the front of the unit without the use of tools.

Airflow Guide Vanes

A motorized guide vane is factory installed, and allows the ability to control the direction of airflow from side to side. A motorized louver provides an automatic change in airflow by directing the air up and down to provide uniform air distribution.

Microprocessor Control

The indoor unit is provided with an integrated control panel to communicate with the outdoor unit. All unit operation parameters are stored in non-volatile memory resident on the unit microprocessor. The microprocessor controls space temperature through using the value provided by the temperature sensor within the indoor unit. The microprocessor control will activate indoor unit operation when the indoor room temperature falls below or rises above a setpoint temperature, at which point, a signal is sent to the outdoor unit to begin the appropriate mode. The microprocessor will also provide self-diagnostics and auto restart functions. A field-supplied four-wire power / communications cable must be installed to connect the indoor unit(s) to the outdoor unit.

Controls

The indoor unit casing has a factory-standard, integral infrared sensor designed to communicate with the supplied LG wireless handheld remote controller. An optional LG supplied wired controller is available as an additional accessory. Communication between the indoor units and the outdoor unit is accomplished through 18 AWG, four-core, stranded and shielded power / communication cable.

Condensate

The unit is designed for gravity draining of condensate and includes a flexible drain hose capable of installation in one of two directions. Unit includes a connection that is compatible with the AquaGuard® AG-9300-LG condensate sensor.

Table 12: Multi F Art Cool Mirror Indoor Unit General Data.

Model Name	LMAN097HVT	LMAN127HVT	LMAN187HVT
Nominal Cooling Capacity (Btu/h) ¹	9,000	12,000	18,000
Nominal Heating Capacity (Btu/h) ¹	10,400	13,800	20,800
<i>Operating Range</i>			
Cooling (°F WB)	57-77	57-77	57-77
Heating (°F DB)	59-81	59-81	59-81
<i>Fan</i>			
Type	Cross Flow	Cross Flow	Cross Flow
Motor Output (W) x Qty.	14.4 x 1	14.4 x 1	76.0 x 1
Motor/Drive	Brushless Digitally Controlled / Direct	Brushless Digitally Controlled / Direct	Brushless Digitally Controlled / Direct
Airflow Rate CFM (H/M/L)	247 / 230 / 212	335 / 318 / 300	572 / 501 / 434
<i>Unit Data</i>			
Refrigerant Type ²	R410A	R410A	R410A
Refrigerant Control	EEV	EEV	EEV
Power Supply V, Ø, Hz ³	208-230, 1, 60	208-230, 1, 60	208-230, 1, 60
Rated Amps (A)	0.2	0.2	0.3
Sound Pressure Level ±3 dB(A) (H/M/L) ⁴	33 / 30 / 27	39 / 36 / 31	37 / 33 / 28
Dimensions (W x H x D, in.)	35-1/4 x 11-3/8 x 8-1/16	35-1/4 x 11-3/8 x 8-1/16	40-9/16 x 12-25/32 x 9-21/32
Net Unit Weight (lbs.)	25	25	35
Shipping Weight (lbs.)	29	29	40
Power Wiring / Communications Cable (No. x AWG) ⁵	4 x 18	4 x 18	4 x 18
Heat Exchanger (Row x Column x Fin / inch) x Number	(2 x 16 x 23) x 1	(2 x 16 x 23) x 1	(3 x 18 x 22) x 1
<i>Piping</i>			
Liquid (in.)	1/4	1/4	1/4
Vapor (in.)	3/8	3/8	1/2
Drain O.D. / I.D. (in.)	27/32, 5/8	27/32, 5/8	27/32, 5/8

¹Nominal capacity is rated 0 ft. above sea level with corresponding refrigerant piping length in accordance with standard length of each outdoor unit and a 0 ft. level difference between outdoor and indoor units. All capacities are net with a combination ratio between 95 – 105%.

Nominal cooling capacity rating obtained with air entering the indoor unit at 80°F dry bulb (DB) and 67°F wet bulb (WB) and outdoor ambient conditions of 95°F dry bulb (DB) and 75°F wet bulb (WB).

Nominal heating capacity rating obtained with air entering the indoor unit at 70°F dry bulb (DB) and 60°F wet bulb (WB) and outdoor ambient conditions of 47°F dry bulb (DB) and 43°F wet bulb (WB).

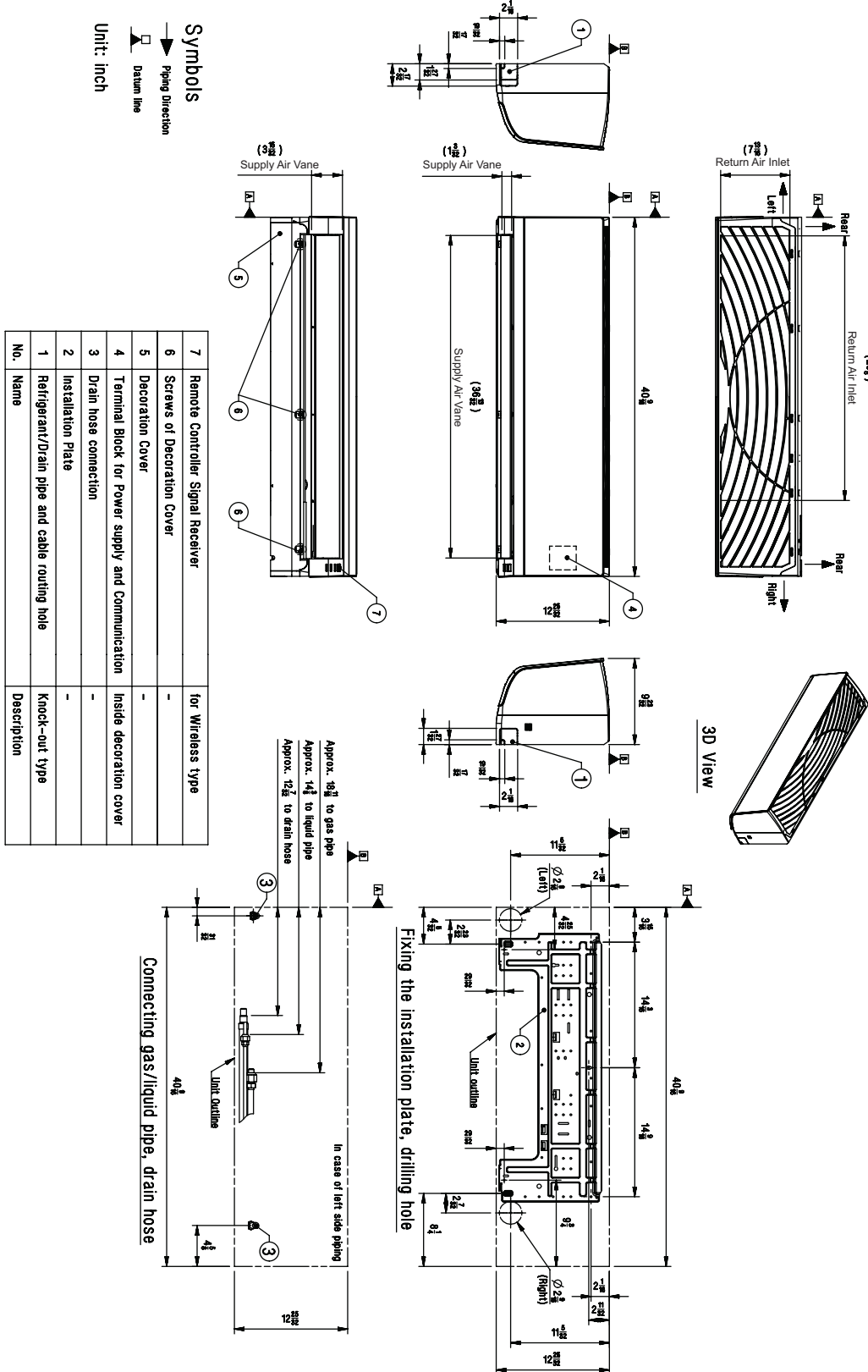
²This unit comes with a dry helium charge.

³Acceptable operating voltage: 187V-253V.

⁴Sound pressure levels are tested in an anechoic chamber under ISO Standard 3745 and are the same in both cooling and heating mode. These values can increase due to ambient conditions during operation.

⁵All power wiring / communications cable to be minimum 18 AWG, 4-conductor, stranded, shielded, and must comply with applicable local and national codes.

Figure 3: LMAN187HVT Dimensions.



ART COOL MIRROR INDOOR UNITS

Cooling Capacity Table

MULTI F
MULTI F MAX

Table 13: Multi F Art Cool Mirror Indoor Units Cooling Capacity Table.

Model No. / Nominal Capacity of Indoor Unit (Btu/h)	Outdoor Air Temp. (°F DB)	Indoor Air Temp. °F DB / °F WB											
		68 / 57		73 / 61		77 / 64		80 / 67		86 / 72		90 / 75	
		TC	SHC	TC	SHC	TC	SHC	TC	SHC	TC	SHC	TC	SHC
LMAN097HVT 9,000	14	8.82	6.04	9.37	6.38	9.92	6.18	10.31	6.31	11.01	6.36	11.56	6.48
	20	8.82	6.09	9.36	6.43	9.91	6.23	10.31	6.36	11.01	6.41	11.55	6.53
	25	8.81	6.13	9.36	6.48	9.90	6.27	10.30	6.41	11.00	6.46	11.54	6.58
	30	8.80	6.18	9.35	6.53	9.90	6.32	10.29	6.46	10.99	6.51	11.54	6.63
	35	8.80	6.23	9.34	6.58	9.89	6.37	10.28	6.50	10.98	6.56	11.53	6.68
	40	8.79	6.28	9.33	6.63	9.88	6.42	10.27	6.55	10.97	6.61	11.52	6.73
	45	8.78	6.32	9.33	6.68	9.87	6.47	10.27	6.60	10.96	6.66	11.51	6.78
	50	8.78	6.37	9.32	6.73	9.87	6.51	10.26	6.65	10.96	6.71	11.50	6.83
	55	8.77	6.42	9.31	6.78	9.86	6.56	10.25	6.70	10.95	6.76	11.49	6.88
	60	8.76	6.46	9.31	6.83	9.85	6.61	10.24	6.75	10.94	6.81	11.48	6.93
	65	8.76	6.51	9.30	6.88	9.84	6.66	10.24	6.80	10.93	6.85	11.47	6.98
	70	8.75	6.56	9.29	6.92	9.84	6.70	10.23	6.85	10.92	6.90	11.47	7.03
	75	8.75	6.61	9.28	6.97	9.83	6.75	10.23	6.90	10.91	6.95	11.46	7.08
	80	8.74	6.66	9.27	7.02	9.83	6.80	10.22	6.95	10.90	7.00	11.45	7.13
	85	8.74	6.71	9.26	7.07	9.82	6.85	10.21	7.00	10.89	7.05	11.44	7.18
	90	8.73	6.76	9.25	7.12	9.82	6.90	10.20	7.05	10.88	7.10	11.43	7.23
	95	8.73	6.81	9.24	7.17	9.81	6.95	10.19	7.10	10.87	7.15	11.42	7.28
	100	8.72	6.86	9.23	7.22	9.81	7.00	10.18	7.15	10.86	7.20	11.41	7.33
	105	8.72	6.91	9.22	7.27	9.80	7.05	10.17	7.20	10.85	7.25	11.40	7.38
	110	8.71	6.96	9.21	7.32	9.80	7.10	10.16	7.25	10.84	7.30	11.39	7.43
115	8.71	7.01	9.20	7.37	9.79	7.15	10.15	7.30	10.83	7.35	11.38	7.48	
118	8.70	7.06	9.19	7.42	9.79	7.20	10.14	7.35	10.82	7.40	11.37	7.53	
122	8.70	7.11	9.18	7.47	9.78	7.25	10.13	7.40	10.81	7.45	11.36	7.58	
LMAN127HVT 12,000	14	11.76	8.51	12.49	8.99	13.22	8.70	13.75	8.88	14.69	8.96	15.42	9.13
	20	11.75	8.57	12.48	9.06	13.21	8.77	13.74	8.95	14.67	9.03	15.40	9.20
	25	11.75	8.64	12.48	9.13	13.20	8.84	13.73	9.02	14.66	9.10	15.39	9.27
	30	11.74	8.71	12.47	9.20	13.19	8.90	13.72	9.09	14.65	9.17	15.38	9.34
	35	11.73	8.77	12.46	9.27	13.18	8.97	13.71	9.16	14.64	9.24	15.37	9.41
	40	11.72	8.84	12.45	9.34	13.17	9.04	13.70	9.23	14.63	9.31	15.36	9.48
	45	11.71	8.90	12.44	9.41	13.16	9.11	13.69	9.30	14.62	9.38	15.35	9.55
	50	11.70	8.97	12.43	9.47	13.15	9.17	13.68	9.37	14.61	9.45	15.33	9.62
	55	11.69	9.03	12.42	9.54	13.14	9.24	13.67	9.44	14.60	9.52	15.32	9.70
	60	11.68	9.10	12.41	9.61	13.13	9.31	13.66	9.50	14.59	9.58	15.31	9.77
	65	11.67	9.17	12.40	9.68	13.12	9.38	13.65	9.57	14.57	9.65	15.30	9.84
	70	11.66	9.23	12.39	9.75	13.11	9.44	13.64	9.64	14.56	9.72	15.29	9.91
	75	11.38	9.08	12.11	9.60	12.83	9.31	13.35	9.51	14.27	9.60	15.00	9.79
	80	11.10	8.92	11.82	9.45	12.55	9.17	13.07	9.38	13.99	9.48	14.71	9.68
	85	10.83	8.76	11.54	9.29	12.26	9.03	12.78	9.24	13.70	9.36	14.42	9.56
	90	10.55	8.60	11.26	9.13	11.98	8.88	12.50	9.10	13.42	9.22	14.13	9.43
	95	10.25	8.51	10.96	9.05	11.67	8.82	12.20	8.90	13.10	9.18	13.81	9.39
	100	10.00	8.28	10.71	8.82	11.42	8.61	11.84	8.76	12.85	8.98	13.56	9.20
	105	9.75	8.05	10.46	8.59	11.17	8.40	11.69	8.62	12.60	8.78	13.31	9.01
	110	9.50	7.77	10.21	8.31	10.92	8.14	11.44	8.37	12.35	8.53	13.07	8.76
115	9.25	7.54	9.96	8.08	10.67	7.92	11.19	8.15	12.10	8.33	12.82	8.56	
118	9.10	7.49	9.81	8.03	10.52	7.88	11.04	8.12	11.95	8.30	12.67	8.54	
122	9.05	7.47	9.76	8.01	10.48	7.87	10.99	8.11	11.90	8.29	12.62	8.53	

TC = Total Capacity (kBtu/h).

SHC: Sensible Heat Capacity (kBtu/h).

Nominal capacity as rated 0 ft. above sea level and a 0 ft. level difference between outdoor and indoor units. Corresponding refrigerant piping length is accordance with standard length of each outdoor unit.

Nominal cooling capacity rating obtained with air entering the indoor unit at 80°F dry bulb (DB) and 67°F wet bulb (WB), and outdoor ambient conditions of 95°F dry bulb (DB) and 75°F wet bulb (WB).

The shaded table columns and rows indicate reference data. When operating at this temperature, these values can be different if the system is not running consistently.

Multi F and Multi F MAX Indoor Unit Engineering Manual

Table 14: Multi F Art Cool Mirror Indoor Units Cooling Capacity Table (continued).

Model No. / Nominal Capacity of Indoor Unit (Btu/h)	Outdoor Air Temp. (°F DB)	Indoor Air Temp. °F DB / °F WB											
		68 / 57		73 / 61		77 / 64		80 / 67		86 / 72		90 / 75	
		TC	SHC	TC	SHC	TC	SHC	TC	SHC	TC	SHC	TC	SHC
LMAN187HVT 18,000	14	17.65	12.33	18.74	13.02	19.84	12.61	20.63	12.88	22.03	12.98	23.12	13.23
	20	17.63	12.43	18.73	13.13	19.82	12.71	20.61	12.98	22.01	13.09	23.11	13.33
	25	17.62	12.52	18.71	13.23	19.81	12.81	20.60	13.08	22.00	13.19	23.09	13.44
	30	17.60	12.62	18.70	13.33	19.79	12.91	20.58	13.18	21.98	13.29	23.07	13.54
	35	17.59	12.71	18.68	13.43	19.78	13.00	20.57	13.28	21.96	13.39	23.05	13.64
	40	17.58	12.81	18.67	13.53	19.76	13.10	20.55	13.38	21.94	13.49	23.04	13.75
	45	17.56	12.90	18.66	13.63	19.75	13.20	20.53	13.48	21.93	13.59	23.02	13.85
	50	17.55	13.00	18.64	13.73	19.73	13.30	20.52	13.58	21.91	13.69	23.00	13.95
	55	17.54	13.10	18.63	13.83	19.72	13.39	20.50	13.68	21.89	13.79	22.98	14.05
	60	17.52	13.19	18.61	13.93	19.70	13.49	20.49	13.78	21.88	13.89	22.97	14.16
	65	17.51	13.29	18.60	14.03	19.69	13.59	20.47	13.87	21.86	13.99	22.95	14.26
	70	17.50	13.38	18.58	14.13	19.67	13.69	20.46	13.97	21.84	14.09	22.93	14.36
	75	17.08	13.16	18.16	13.92	19.24	13.49	20.03	13.79	21.41	13.92	22.50	14.20
	80	16.66	12.93	17.74	13.70	18.82	13.30	19.60	13.60	20.98	13.75	22.06	14.03
	85	16.24	12.70	17.32	13.47	18.40	13.09	19.17	13.40	20.55	13.56	21.63	13.85
	90	15.82	12.46	16.90	13.23	17.97	12.88	18.75	13.19	20.12	13.37	21.20	13.67
	95	15.37	12.33	16.44	13.12	17.51	12.78	18.00	12.90	19.65	13.30	20.72	13.61
	100	14.99	12.00	16.06	12.78	17.13	12.47	17.77	12.70	19.28	13.01	20.35	13.33
105	14.62	11.67	15.69	12.45	16.76	12.17	17.53	12.50	18.90	12.73	19.97	13.05	
110	14.24	11.27	15.32	12.05	16.39	11.79	17.16	12.13	18.53	12.36	19.60	12.70	
115	13.87	10.93	14.94	11.71	16.01	11.48	16.79	11.82	18.15	12.07	19.22	12.41	
118	13.65	10.85	14.72	11.64	15.79	11.42	16.56	11.77	17.93	12.03	19.00	12.37	
122	13.57	10.83	14.64	11.62	15.71	11.40	16.49	11.75	17.85	12.01	18.92	12.36	

TC = Total Capacity (kBtu/h).

SHC: Sensible Heat Capacity (kBtu/h).

Nominal capacity as rated 0 ft. above sea level and a 0 ft. level difference between outdoor and indoor units. Corresponding refrigerant piping length is accordance with standard length of each outdoor unit.

Nominal cooling capacity rating obtained with air entering the indoor unit at 80°F dry bulb (DB) and 67°F wet bulb (WB), and outdoor ambient conditions of 95°F dry bulb (DB) and 75°F wet bulb (WB).

The shaded table columns and rows indicate reference data. When operating at this temperature, these values can be different if the system is not running consistently.

ART COOL MIRROR INDOOR UNITS

Heating Capacity Table

MULTI F
MULTI F MAX

Table 15: Multi F Art Cool Mirror Indoor Units Heating Capacity Table.

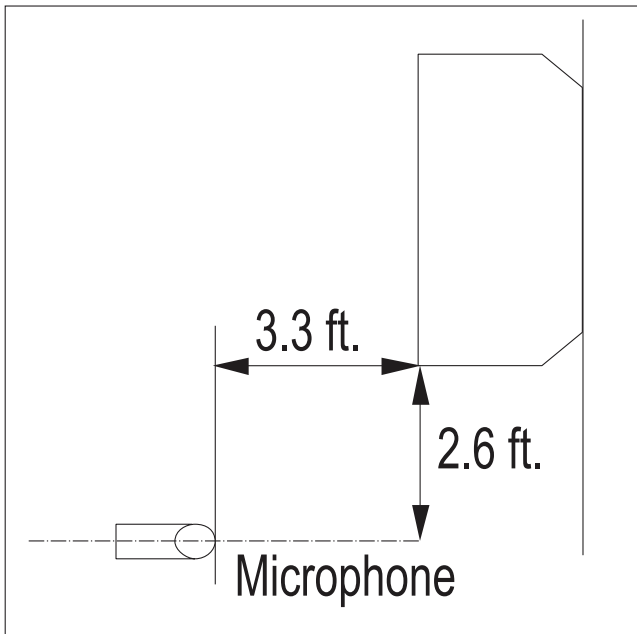
Model No. / Nominal Capacity of Indoor Unit (Btu/h)	Outdoor Air Temp.		Indoor Air Temp. °F DB					
	°F DB	°F WB	61	64	68	70	72	75
			TC	TC	TC	TC	TC	TC
LMAN097HVT 9,000	0	-0.4	5.35	5.28	5.23	5.20	5.12	4.90
	5	4.5	6.03	5.95	5.90	5.88	5.80	5.58
	10	9	6.71	6.63	6.58	6.56	6.48	6.26
	17	15	7.61	7.54	7.49	7.46	7.39	7.14
	20	19	7.95	7.88	7.83	7.80	7.72	7.46
	25	23	8.52	8.44	8.39	8.37	8.29	7.99
	30	28	9.01	8.93	8.88	8.86	8.78	8.52
	35	32	9.50	9.42	9.37	9.34	9.27	9.04
	40	36	9.94	9.86	9.81	9.78	9.71	9.48
	45	41	10.37	10.30	10.25	10.22	10.15	9.92
	47	43	10.55	10.48	10.43	10.40	10.32	10.10
	50	46	10.72	10.64	10.59	10.57	10.49	10.24
	55	51	11.00	10.93	10.88	10.85	10.78	10.48
	60	56	11.00	10.93	10.88	10.85	10.78	10.52
	63	59	11.00	10.93	10.88	10.85	10.78	10.55
68	64	11.00	10.93	10.88	10.85	10.78	10.60	
LMAN127HVT 12,000	0	-0.4	7.10	7.00	6.93	6.90	6.80	6.50
	5	4.5	8.00	7.90	7.83	7.80	7.70	7.40
	10	9	8.90	8.80	8.73	8.70	8.60	8.30
	17	15	10.10	10.00	9.93	9.90	9.80	9.48
	20	19	10.55	10.45	10.38	10.35	10.25	9.90
	25	23	11.30	11.20	11.13	11.10	11.00	10.60
	30	28	11.95	11.85	11.78	11.75	11.65	11.30
	35	32	12.60	12.50	12.43	12.40	12.30	12.00
	40	36	13.18	13.08	13.02	12.98	12.88	12.58
	45	41	13.77	13.67	13.60	13.57	13.47	13.17
	47	43	14.00	13.90	13.83	13.80	13.70	13.40
	50	46	14.23	14.13	14.06	14.03	13.93	13.59
	55	51	14.60	14.50	14.43	14.40	14.30	13.90
	60	56	14.60	14.50	14.43	14.40	14.30	13.96
	63	59	14.60	14.50	14.43	14.40	14.30	14.00
68	64	14.60	14.50	14.43	14.40	14.30	14.06	
LMAN187HVT 18,000	0	-0.4	10.70	10.55	10.45	10.40	10.25	9.80
	5	4.5	12.06	11.91	11.81	11.76	11.61	11.15
	10	9	13.41	13.26	13.16	13.11	12.96	12.51
	17	15	15.22	15.07	14.97	14.92	14.77	14.29
	20	19	15.90	15.75	15.65	15.60	15.45	14.92
	25	23	17.03	16.88	16.78	16.73	16.58	15.98
	30	28	18.01	17.86	17.76	17.71	17.56	17.03
	35	32	18.99	18.84	18.74	18.69	18.54	18.09
	40	36	19.87	19.72	19.62	19.57	19.42	18.97
	45	41	20.75	20.60	20.50	20.45	20.30	19.85
	47	43	21.10	20.95	20.85	20.80	20.65	20.20
	50	46	21.44	21.29	21.19	21.14	20.99	20.48
	55	51	22.01	21.86	21.75	21.70	21.55	20.95
	60	56	22.01	21.86	21.75	21.70	21.55	21.04
	63	59	22.01	21.86	21.75	21.70	21.55	21.10
68	64	22.01	21.86	21.75	21.70	21.55	21.20	

TC = Total Capacity (kBtu/h).

Nominal capacity as rated 0 ft. above sea level and a 0 ft. level difference between outdoor and indoor units. Corresponding refrigerant piping length is accordance with standard length of each outdoor unit.

Nominal heating capacity rating obtained with air entering the indoor unit at 70°F dry bulb (DB) and 60°F wet bulb (WB), and outdoor ambient conditions of 47°F dry bulb (DB) and 43°F wet bulb (WB).

Figure 4: Sound Pressure Level Measurement Location.

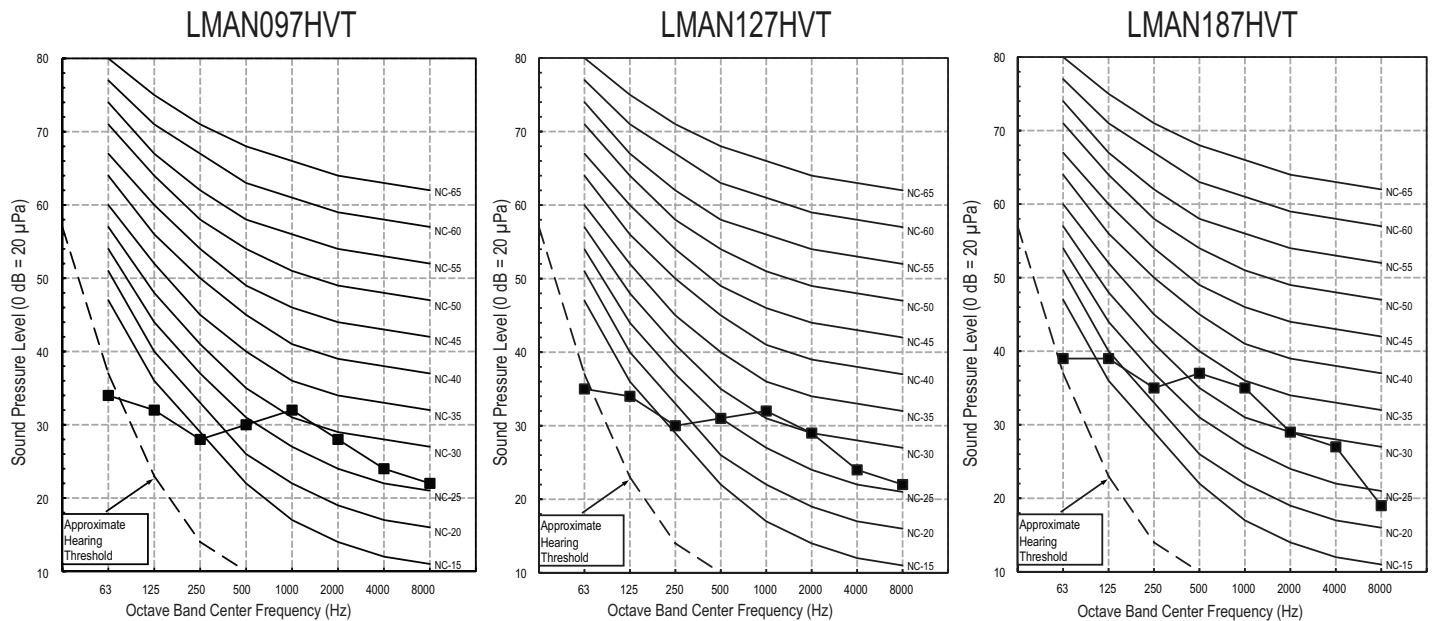


- Measurement taken 2.6' below the bottom of the unit and at a distance of 3.3' from face of unit.
- Measurements taken with no attenuation and units operating at full load normal operating condition.
- Sound level will vary depending on a range of factors such as construction (acoustic absorption coefficient) of particular area in which the equipment is installed.
- Sound power levels are measured in dB(A)±3.
- Tested in anechoic chamber per ISO Standard 3745.

Table 16: Sound Pressure Levels (dB[A]).

Model No.	Sound Pressure Levels (dB[A]) (Cooling and Heating)		
	High Fan Speed	Medium Fan Speed	Low Fan Speed
LMAN097HVT	33	30	27
LMAN127HVT	39	36	31
LMAN187HVT	37	33	28

Figure 5: Sound Pressure Level Diagrams.



ART COOL MIRROR INDOOR UNITS

Air Velocity and Temperature Distribution

MULTI F
MULTI F MAX

Figure 6: LMAN097HVT Air Velocity and Temperature Distribution Charts.

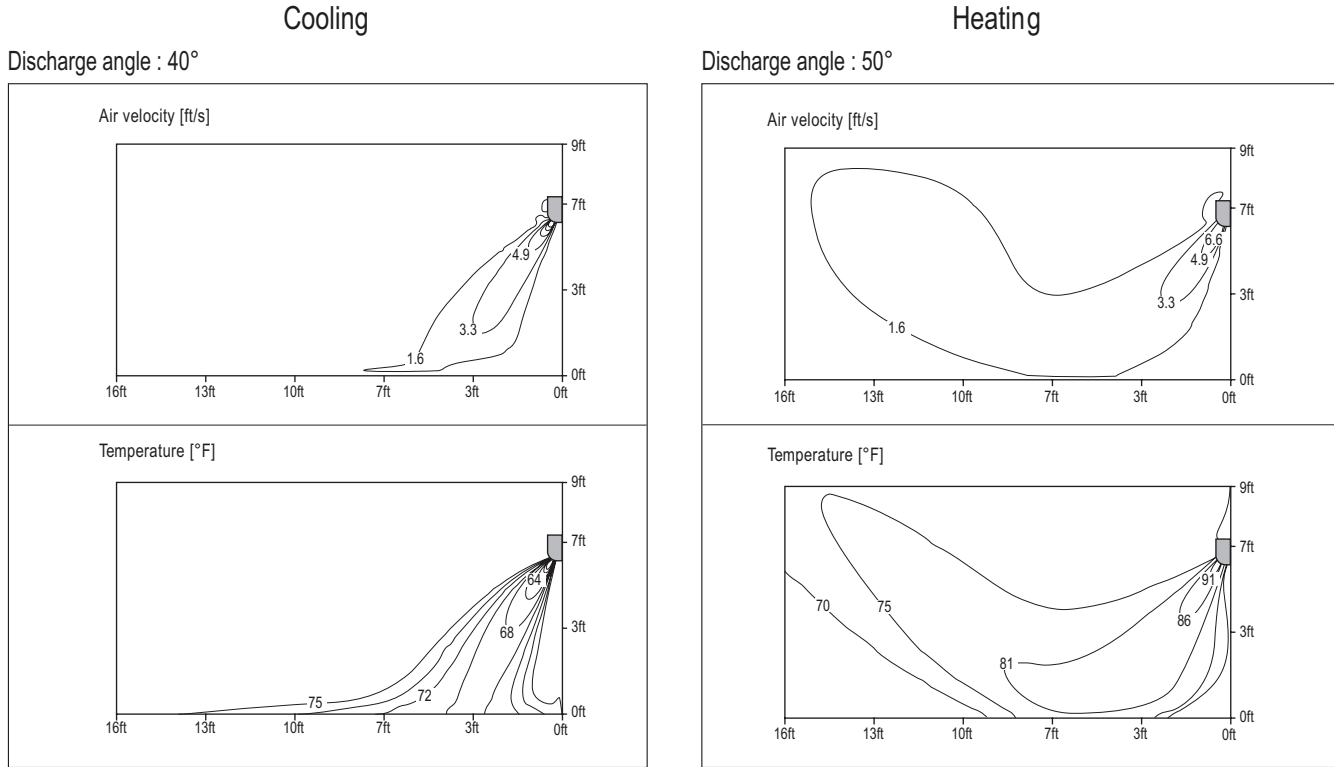
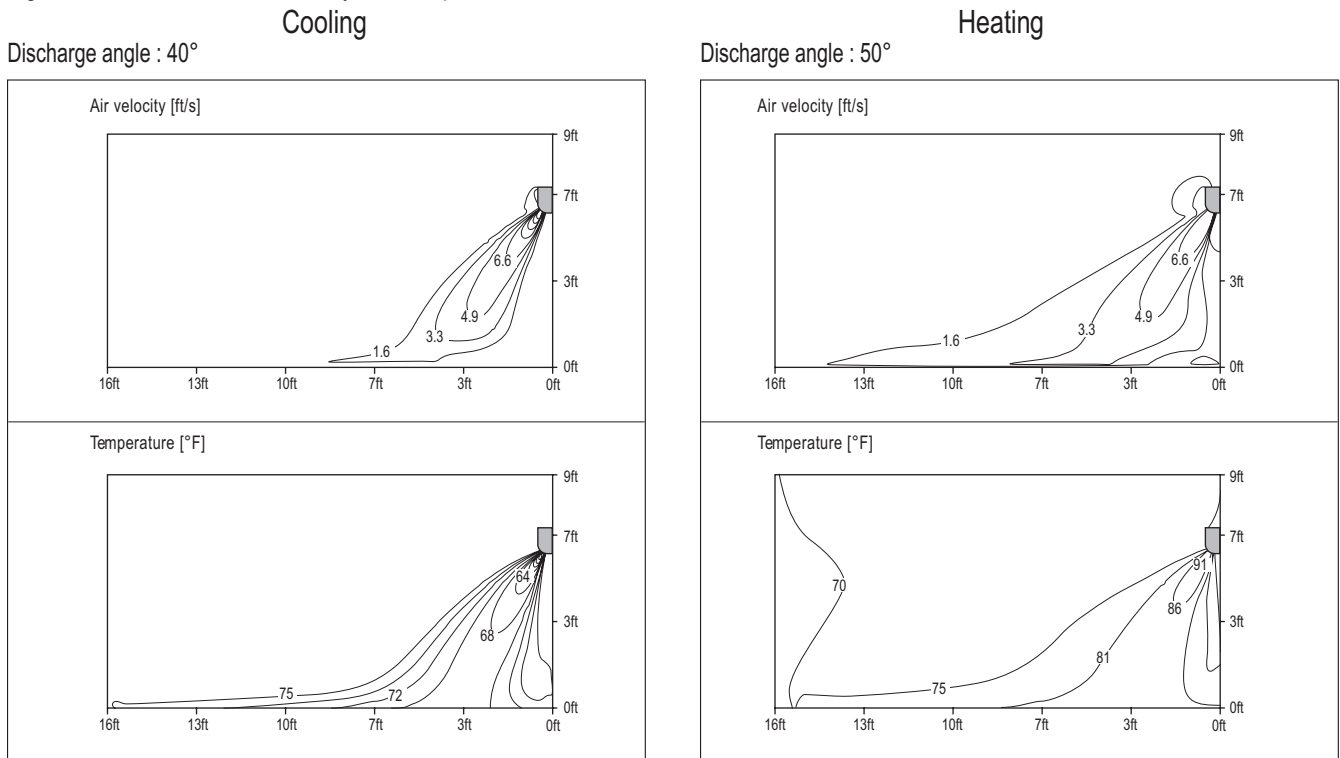


Figure 7: LMAN127HVT Air Velocity and Temperature Distribution Charts.

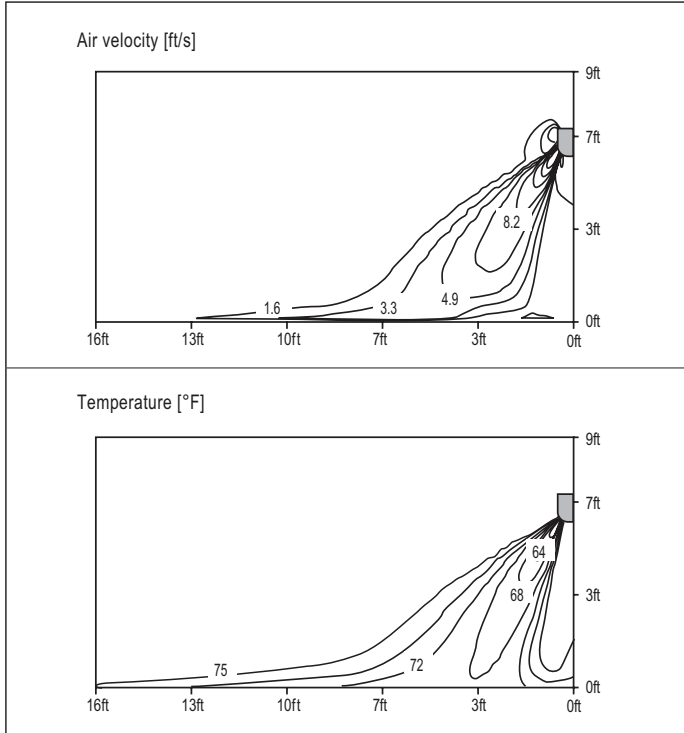


Multi F and Multi F MAX Indoor Unit Engineering Manual

Figure 8: LMAN187HVT Air Velocity and Temperature Distribution Charts.

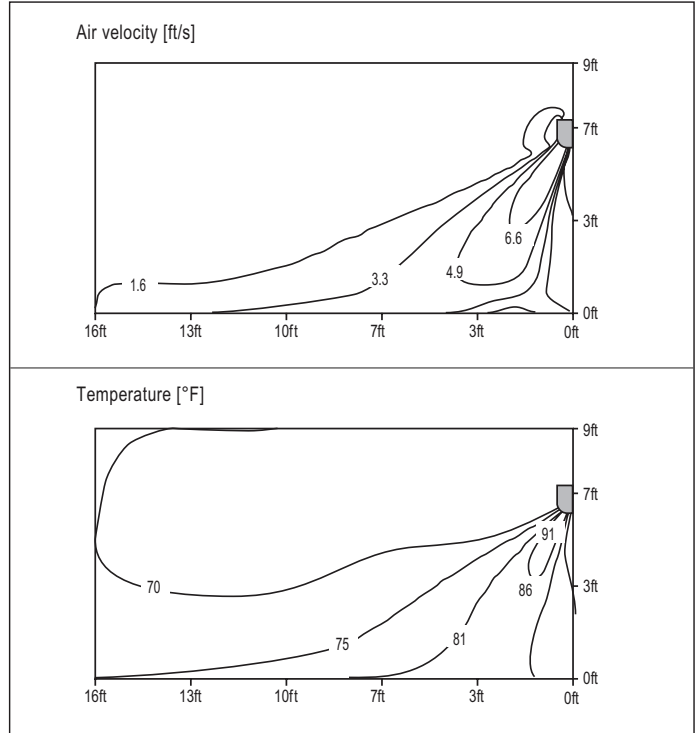
Cooling

Discharge angle : 40°



Heating

Discharge angle : 50°



ART COOL MIRROR INDOOR UNITS

Refrigerant Flow Diagram

MULTI F
MULTI F MAX

Figure 9: Art Cool Mirror Indoor Unit Refrigerant Flow Diagram.

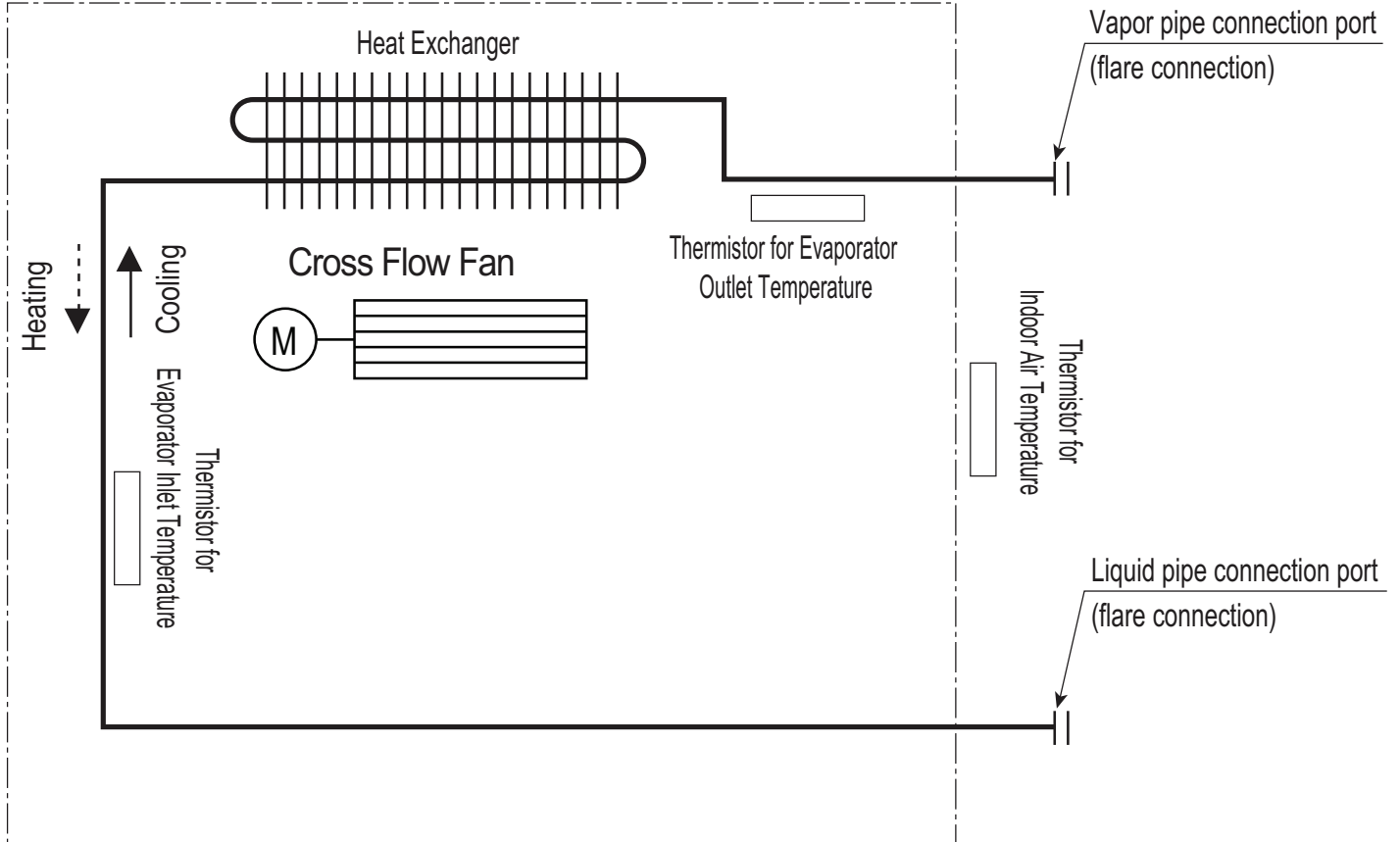


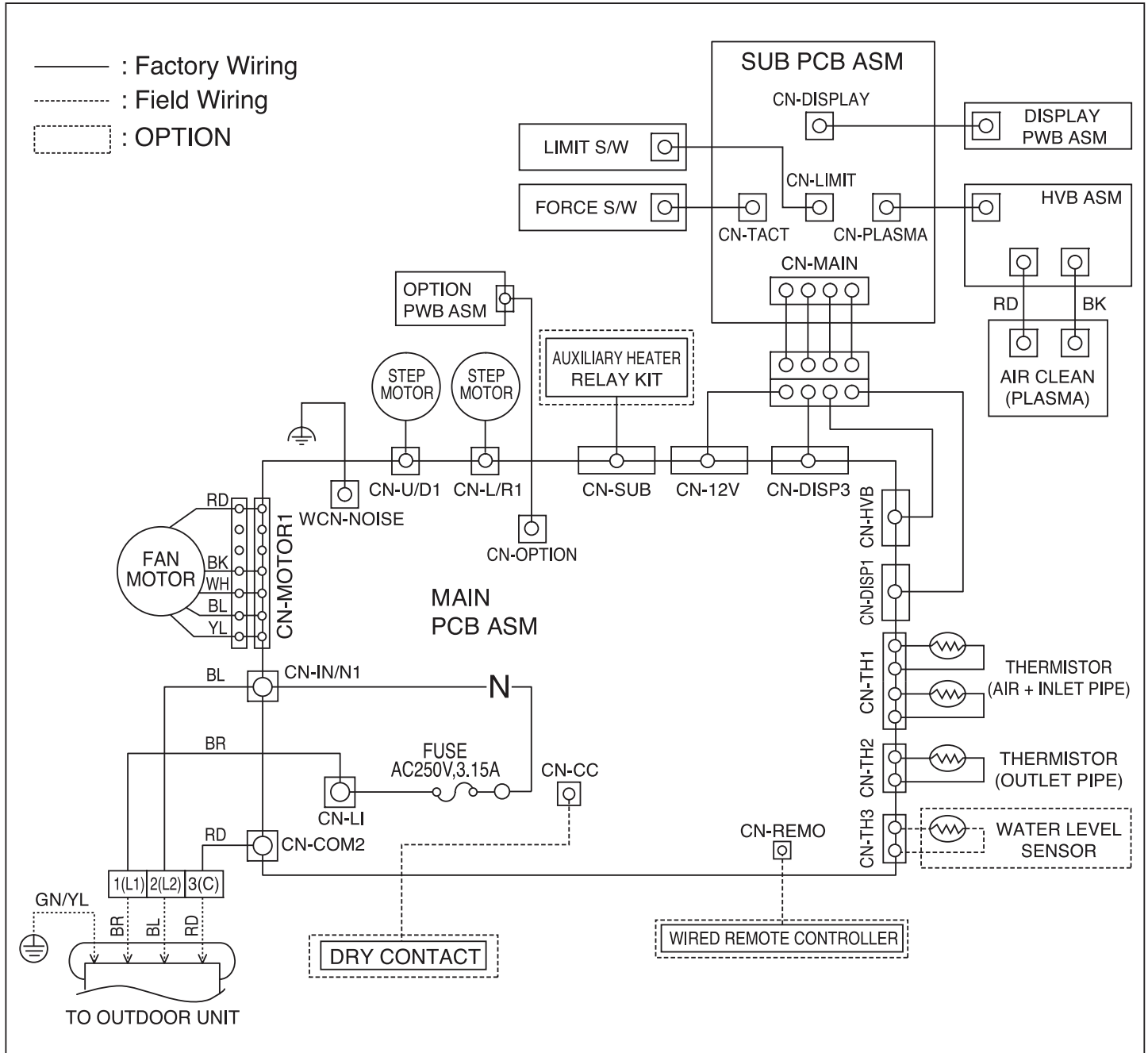
Table 17: Art Cool Mirror Indoor Unit Refrigerant Pipe Connection Port Diameters.

Model No.	Vapor (inch)	Liquid (inch)
LMAN097HVT	Ø3/8	Ø1/4
LMAN127HVT		
LMAN187HVT	Ø1/2	Ø1/4

Table 18: Art Cool Mirror Indoor Unit Thermistor Details.

Description (Based on Cooling Mode)	PCB Connector
Indoor Air Temperature Thermistor	CN-TH1
Evaporator Inlet Temperature Thermistor	
Evaporator Outlet Temperature Thermistor	CN-TH2
Water Level Sensor (Optional)	CN-TH3

Figure 10: Multi F Art Cool Mirror LMAN097HVT and LMAN127HVT Indoor Units Wiring Diagram.

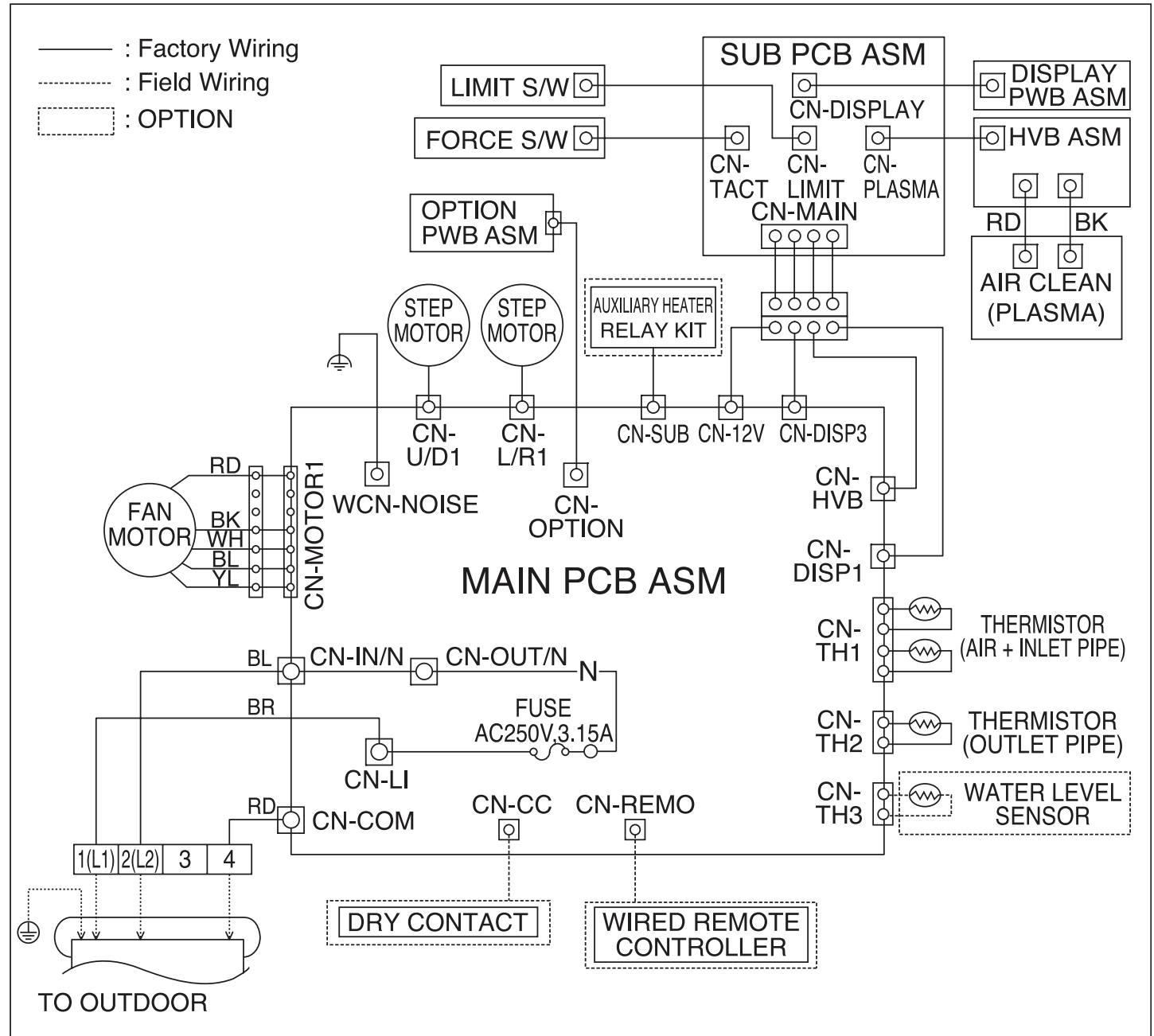


ART COOL MIRROR INDOOR UNITS

Wiring Diagram

MULTI F
MULTI F MAX

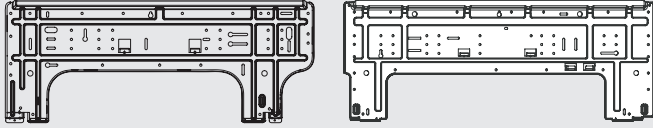
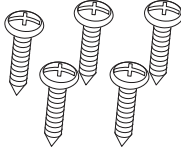
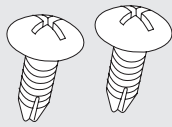

Figure 11: Multi F Art Cool Mirror LMAN187HVT Indoor Unit Wiring Diagram.



Multi F and Multi F MAX Indoor Unit Engineering Manual

Factory Supplied Parts

Table 19: Parts Table.

Part	Quantity	Image
Installation Plate	One (1)	 <p>LMAN097HVT and LMAN127HVT LMAN187HVT</p>
Type "A" Screws	Five (5)	
Type "B" Screws (M4 x 12L)	Two (2)	
Wireless Handheld Controller with Holder (AKB73635606)	One (1)	

Factory Supplied Materials

- Owner's Manual
- Installation Manual

Required Tools

- Level
- Screwdriver
- Electric drill
- Hole core drill
- Flaring tool set
- Spanner (Half union)
- Thermometer

⚠️ WARNING

- Read all instructions before installing the product.
- Installation work must be performed by authorized personnel and in accordance with the national wiring standards and all local codes.

ART COOL MIRROR INDOOR UNITS

Installation and Best Layout Practices

MULTI F
MULTI F MAX

Selecting the Best Location

Do's

- Place the unit where air circulation will not be blocked.
- Place the unit where drainage can be obtained easily.
- Place the unit where noise prevention is taken into consideration.
- Ensure there is sufficient space from the ceiling and floor.
- Ensure there is sufficient maintenance space.
- Locate the indoor unit in a location where it can be easily connected to the outdoor unit / branch distribution unit.

⚠ WARNING

Don'ts

- The unit should not be installed near a heat or steam source, or where considerable amounts of oil, iron powder, or flour are used.
- The unit should not be installed where sulfuric acid and flammable or corrosive gases are generated, vented into, or stored.
- Avoid installing the unit near high-frequency generators.
- Do not install the unit near a doorway.

The unit may be damaged, may malfunction, and / or will not operate as designed if installed in any of the conditions listed.

Installing in an Area Exposed to Unconditioned Air

In some installation applications, areas (floors, walls) in some rooms may be exposed to unconditioned air (room may be above or next to an unheated garage or storeroom). To countermeasure:

- Verify that carpet is or will be installed (carpet may increase the temperature by three degrees).
- Add insulation between the floor joists.
- Install radiant heat or another type of heating system to the floor.

Mounting the Installation Plate

The mounting wall should be strong and solid enough to protect the unit from vibration.

- Mount the installation plate on the wall using the Type "A" screws. If mounting the unit on concrete, consider using anchor bolts.
- Always mount the installation plate horizontally. Measure the wall and mark the centerline using thread and a level.

Figure 12: Minimum Clearance Requirements.

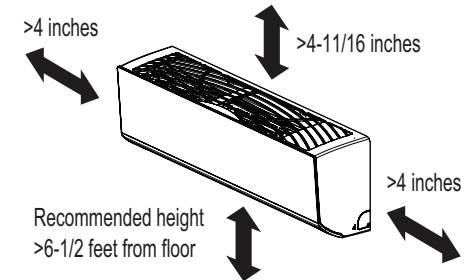


Figure 13: Installation Plate—Side View.

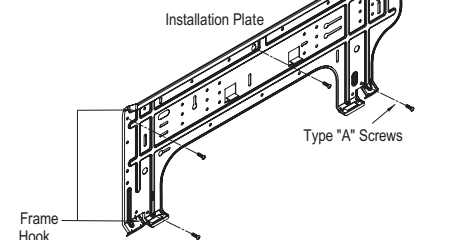


Figure 14: Installation Plate for LMAN097HVT and LMAN127HVT Units.

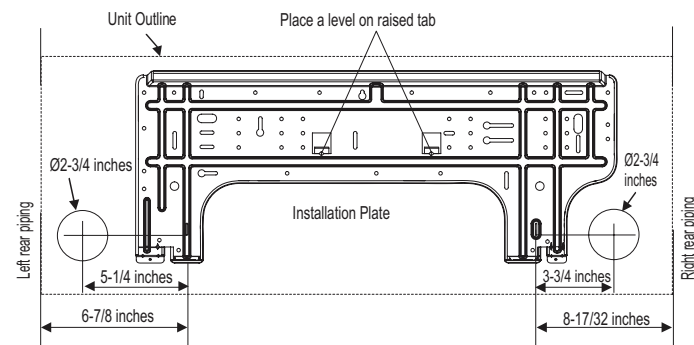
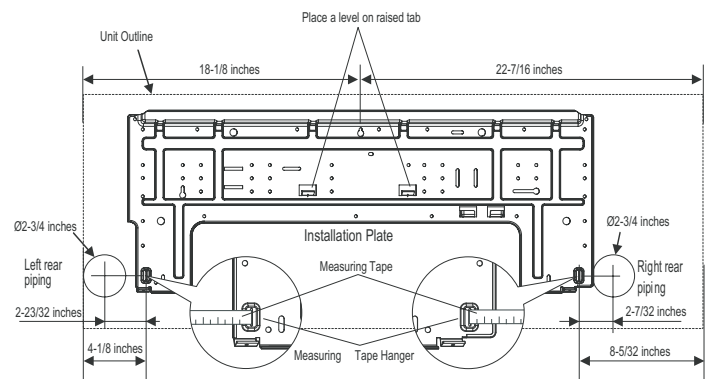


Figure 15: Installation Plate for LMAN187HVT Units.



⚠ WARNING

If the unit is installed near a body of water, certain components are at risk of being corroded. Appropriate anti-corrosion methods should be taken for the unit and all components.

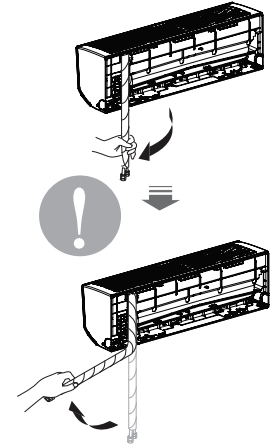
Preparing for Installation

Prepare the refrigerant piping and drain hose (indoor unit piping) for installation through the wall: press on the top of the tubing clamp and slowly guide the piping / hose down (depending on installation requirements, then to the left or right). Relock the tubing clamp after the piping / hose are released.

Note:

Do not bend the piping / drain hose from side to side, it may damage the components.

Figure 16: Preparing for Installation.



Hanging the Indoor Unit Frame

1. Attach the three (3) hooks on the top of the indoor unit to the top edge of the installation plate. Verify the hooks are properly attached to the installation plate by gently shaking the indoor unit from side to side.
2. Unlock the tubing clamp from the indoor unit frame. For easier access between the bottom of the indoor unit and the wall, prop the clamp between the indoor unit frame and installation plate.
3. Remove the screw covers at the bottom of the indoor unit, unscrew the two (2) screws, remove the frame cover, remove the piping connection cover, and position the piping for installation (down, back, left, or right).

Figure 17: Locking the Indoor Unit onto the Installation Plate.

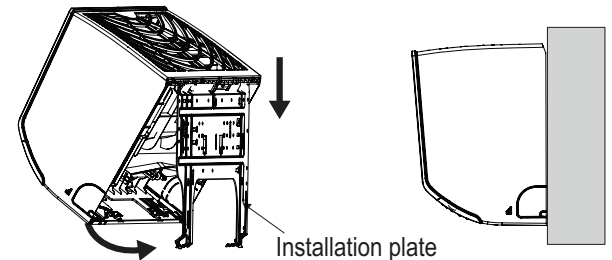


Figure 18: Accessing the Back of the Indoor Unit.

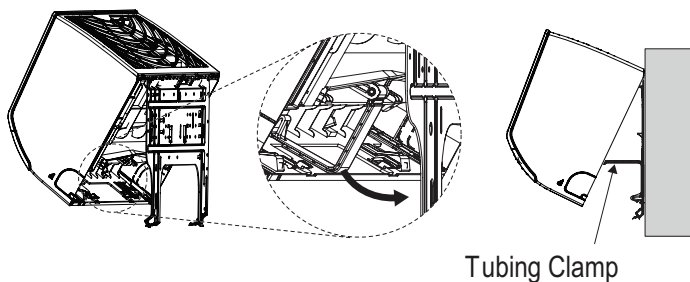


Figure 19: Removing the Frame Cover.

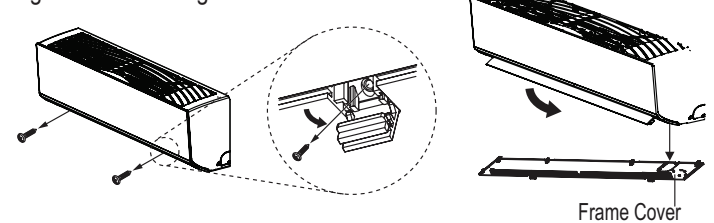


Figure 20: Exterior Back View of Indoor Unit.

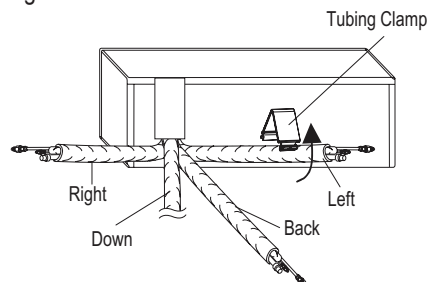


Figure 21: Piping Installed to the Left.

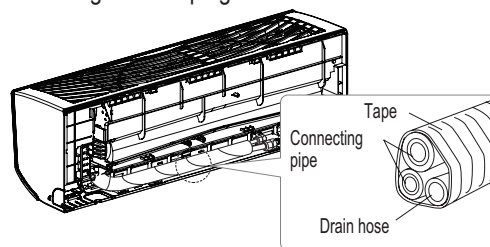
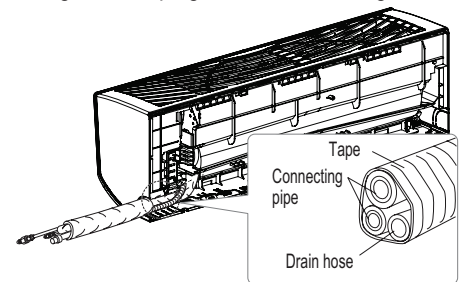


Figure 22: Piping Installed to the Right.



Connecting the Indoor Unit Piping to the Field-Installed Piping

1. Center align the indoor unit piping (refrigerant and drain) and the field-installed piping, then hand tighten the flare nut.
2. Tighten the flare nut with a torque wrench.
3. Attach the drain tube piping to the indoor unit drain hose as shown.

Figure 23: Indoor Unit to Field-Installed Piping Connection.

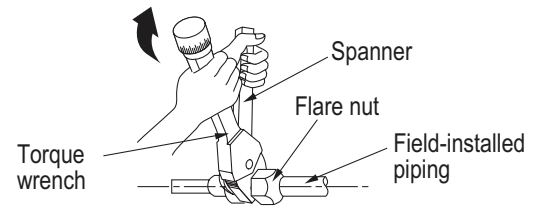
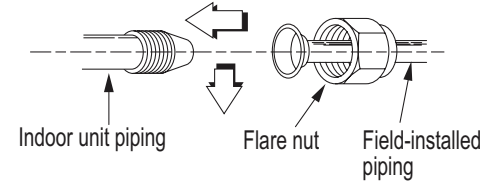


Figure 25: Insulating the Piping.

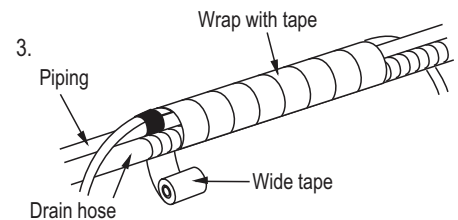
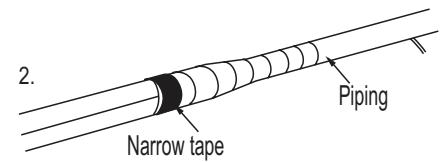
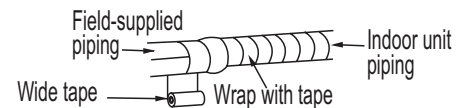
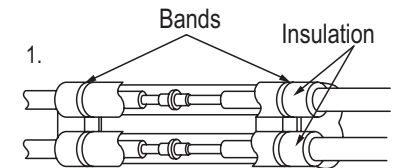
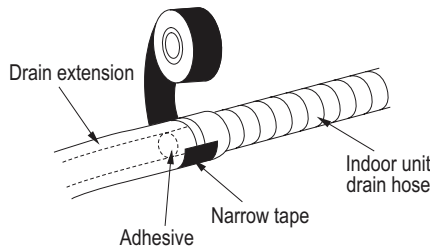


Figure 24: Extending the Drain Hose.



Note:

If the drain hose is routed inside a room, add insulation to prevent condensate from forming.

Insulating the Refrigerant and Drain Piping

Refrigerant Piping Insulation

Field-installed vapor and liquid refrigerant piping lines must be properly and completely covered in insulation (up to the indoor unit piping connections). Any exposed piping may generate condensate or will cause burns if touched. Insulation for this field-installed refrigerant piping must have a minimum heat resistance of 248°F.

Drain Piping Insulation

Drain piping must have insulation a minimum of 7/32 inches thick.

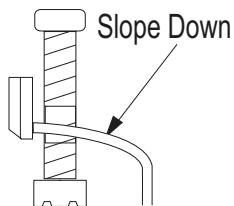
Installing the Insulation

1. Overlap the insulation at the connection of the field-installed piping and the indoor unit piping. Tape together so that no gaps exist.
2. Secure insulation to the rear piping housing section with vinyl tape.
3. Bundle the piping and drain hose with tape where they meet at the back of the indoor unit frame. Position the drain hose at the bottom of the bundle (positioning the drain hose at the top of the bundle may cause the drain pan to overflow inside the indoor unit).

Drain Slope

Drain hose should point down so water can flow away easily.

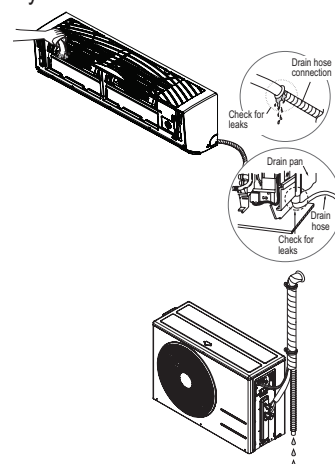
Figure 26: Drain Piping Slope.



Checking the Drainage System

1. Pour water on the indoor unit evaporator.
2. Ensure the water flows through and out of the hose and away from the indoor unit without leaking.

Figure 27: Checking the Drainage System.



Power Wiring / Communications Cable Guidelines

- Follow manufacturer's circuit diagrams in the technical manuals.
- Confirm power source specifications.
- Confirm that the electrical capacity is sufficient.
- Starting current must be maintained ± 10 percent of the rated current marked on the outdoor unit name plate.
- Confirm cable thickness specifications.
- It is recommended that a circuit breaker is installed, especially if conditions could become wet or moist.
- Include a disconnect in the power wiring system, add an air gap contact separation of at least 1/8 inch in each active (phase) conductor.

⚠ WARNING

- Loose wiring may cause unit malfunction, or the terminal to overheat and catch fire.
- Terminal screws may become loose during transport. Properly tighten the terminal connections during installation.

A voltage drop may cause the following problems:

- Magnetic switch vibration, fuse breaks, or disturbance to the normal function of an overload protection device.
- Compressor will not receive the proper starting current.

Connecting the Power Wiring and Communications Cable

1. Insert the power wiring / communications cable from the outdoor unit or branch distribution unit (Multi F MAX systems only) through the bottom of the indoor unit.
2. Connect each wire to its appropriate terminal on the indoor unit control board. Verify that the color and terminal numbers from the outdoor unit or branch distribution unit (Multi F MAX systems only) wiring match the color and terminal numbers on the indoor unit.
3. Secure the power wiring / communications cable with the cable restraint.

Figure 28: Connecting the Power Wiring / Communications Cable.

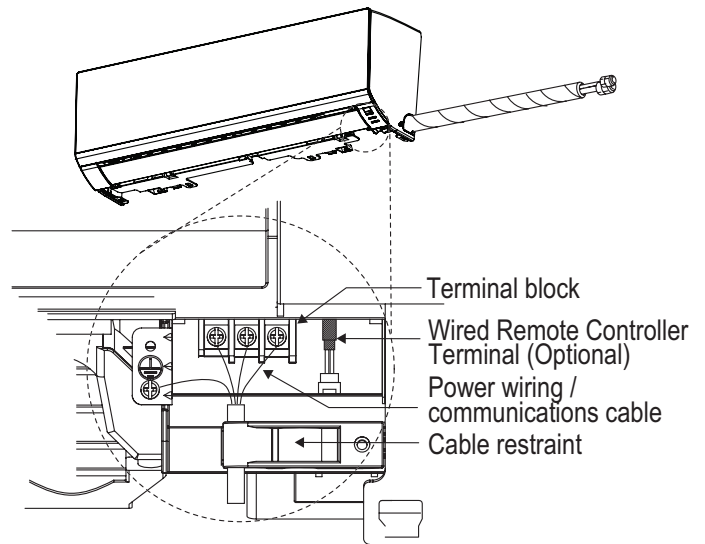


Figure 29: Simplified View of Indoor Unit to Outdoor Unit / Branch Distribution Unit Terminal Connections—LMAN097HVT and LMAN127HVT models.

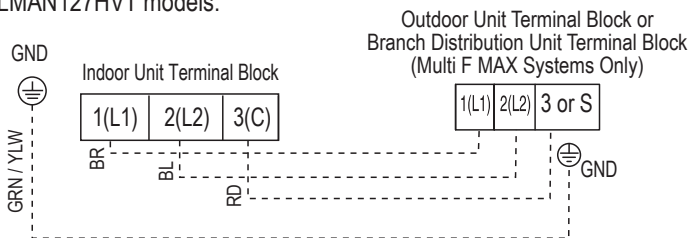
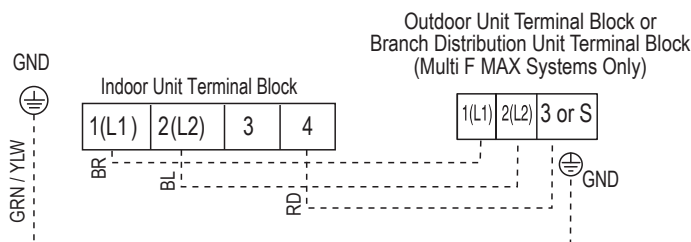


Figure 30: Simplified View of Indoor Unit to Outdoor Unit / Branch Distribution Unit Terminal Connections—LMAN187HVT models.



ART COOL MIRROR INDOOR UNITS

Installation and Best Layout Practices

MULTI F
MULTI F MAX

Controller Options

Art Cool Mirror wall-mounted indoor units include a wireless controller (AKB73635606), but optional LG-supplied wired controllers are available (see Controls and Options overview on pages 9 to 12 in this manual's Introduction section).

Wireless Handheld Controller

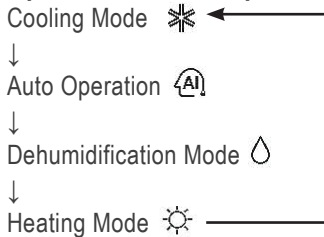
Figure 31: AKB73635606 Wireless Controller.



Table 20: AKB73635606 Wireless Controller Functions.

Control Panel Button	Display Screen	Description
		Plasma Button: Plasma filter helps remove air impurities.
		Sleep Mode Button ¹ : Sets the sleep mode auto operation.
		Temperature Adjustment Buttons: Raises or lowers temperature setpoint in cooling and heating operation.
	-	On / Off Button: Turns the power on/off.
		Indoor Fan Speed Button: Changes the fan speed.
		Operation mode selection button ¹ : Selects the operation mode. Cooling operation / Auto operation or auto changeover / Dehumidifying operation / Heating operation / Air circulation
		Jet Cool / Jet Heat Button ¹ : Warms up or cools down the indoor temperature within a short period.
		Air Flow Direction Button: Adjusts the airflow direction vertically or horizontally.
		Temperature Display Button: Displays the room temperature. Press and hold button down for five (5) seconds. Display changes from °C to °F.
		Timer button: Sets the current time and the start / end times.
		Navigation / Functions Button ¹ : Adjusts the time and sets the special functions. Auto clean / Operates energy saving cooling / Adjusts the brightness of the indoor unit display
	-	Set / Clear Button: Sets or cancels functions.
	-	Reset Button: Resets the air conditioner settings.

Operation Mode Sequence



¹Depending on the indoor unit model, some functions may not be supported.

Wired Controller Connections

Figure 32: Wired Controller Connection on the Indoor Unit Terminal Block—LMAN097HVT and LMAN127HVT models.

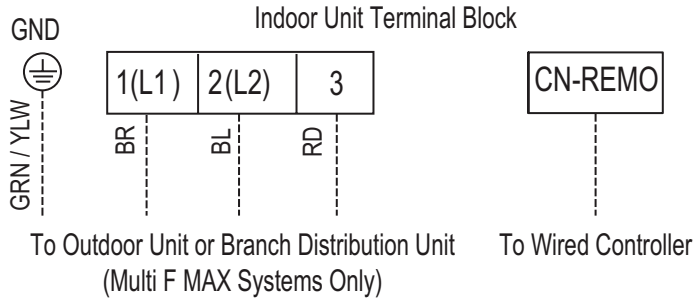
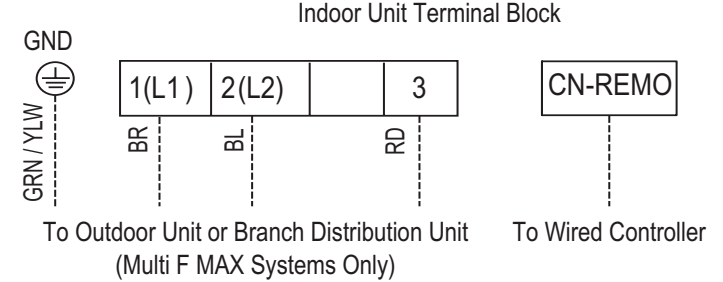


Figure 33: Wired Controller Connection on the Indoor Unit Terminal Block—LMAN187HVT models.



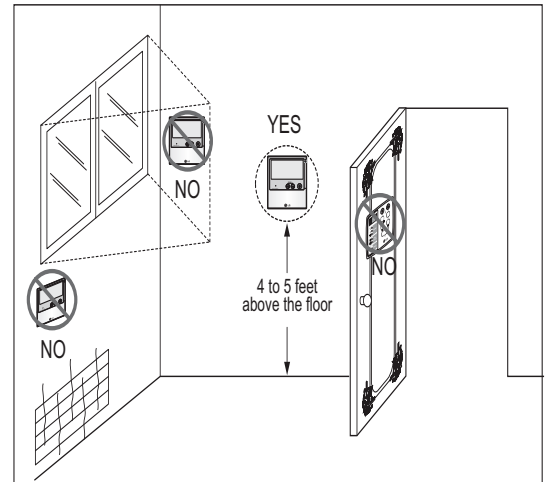
Wired Controller Placement

Wired controllers include a sensor to detect room temperature. To maintain comfort levels in the conditioned space, the wired controller must be installed in a location away from direct sunlight, high humidity, and where it could be directly exposed to cold air. Controller must be installed four (4) to five (5) feet above the floor where its LED display can be read easily, in an area with good air circulation, and where it can detect an average room temperature.

Do not install the wired controller near or in:

- Drafts or dead spots behind doors and in corners
- Hot or cold air from ducts
- Radiant heat from the sun or appliances
- Concealed pipes and chimneys
- An area where temperatures are uncontrolled, such as an outside wall

Figure 34: Proper Location for the Wired Controller.



ART COOL MIRROR INDOOR UNITS

Installation and Best Layout Practices

MULTI F
MULTI F MAX

Hanging the Wired Controller

1. The controller wiring / cable can be installed in one of three directions: top, back, or on the right side. If top or right side installation is desired, remove cable guide grooves on the controller, and then position wiring / cable on applicable side.
2. Choose and mark the area of installation, and then screw the wall plate into place (using the provided parts). Install the controller wall plate to fit the electrical box if one is present. Ensure that no gaps exist between the wall plate and the wall itself.
3. Arrange wiring / cables so as not to interfere with the controller circuitry. Position the wired controller on the wall plate. Snap into place by pressing the bottom part of the wired controller onto the wall plate. Make sure that no gaps exist between the wired controller and the wall plate on all sides.
4. To remove wired controller from the wall plate, insert a screwdriver into the two holes at the bottom. Twist screwdriver to release controller. Do not damage the controller components when removing.

Assigning the Thermistor for Temperature Detection

Each indoor unit includes a return air thermistor assigned to sense the temperature. If a wired controller is installed, there is a choice of sensing temperature with either the indoor unit return air thermistor or the thermistor in the wired controller. It is also an option to set both thermistors to sense temperature so that indoor unit bases its operation on the first thermistor to reach the designated temperature differential. For applicable indoor units, an optional Remote Temperature Sensor can be used in lieu of the return air thermistor—either alone or in conjunction with a wired controller thermistor as previously described.

Finalizing Indoor Unit Installation

1. Move the tubing clamp to its original position.
2. Ensure the three (3) hooks are properly attached to the installation plate by gently shaking the indoor unit from side to side.
3. Press the bottom left and right sides of the indoor unit against the installation plate until the hooks click firmly into their slots.
4. Using two (2) Type “C” screws, secure the bottom of the indoor unit to the installation plate.
5. Remove the two (2) tabs from the filter.
6. Replace the frame cover.

Figure 35: Removing the Cable Guide Grooves.

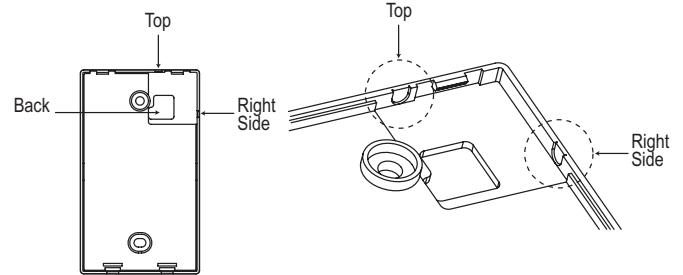


Figure 36: Attaching the Wall Plate.

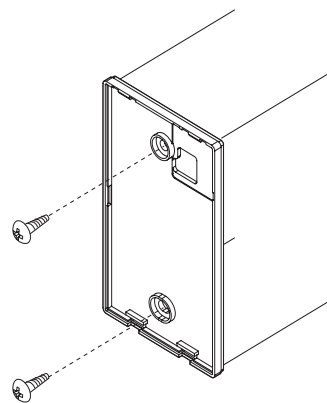


Figure 37: Installing / Removing the Controller.

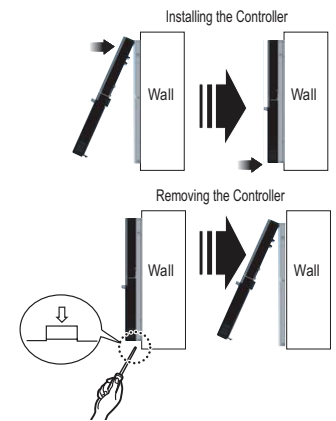


Figure 38: Attach the bottom of the indoor unit to the installation plate.

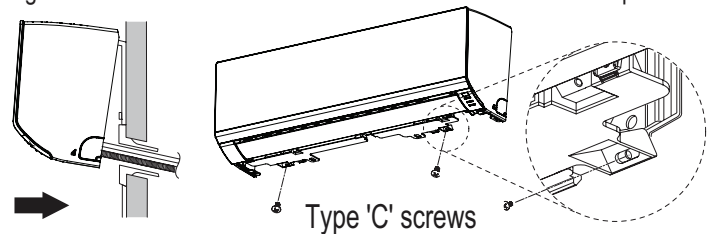
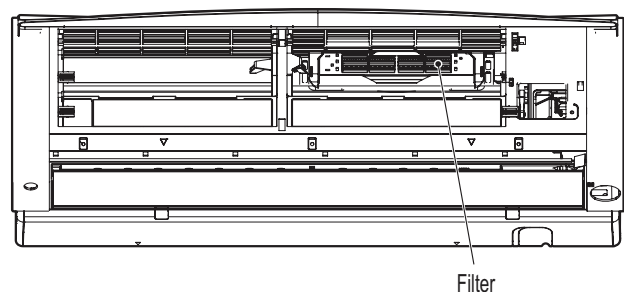


Figure 39: Removing the Filter Tabs.



ART COOL™ GALLERY INDOOR UNIT DATA

“Mechanical Specifications” on page 38

“General Data / Specifications” on page 39

“Dimensions” on page 40

“Cooling Capacity Table” on page 41

“Heating Capacity Table” on page 42

“Acoustic Data” on page 43

“Air Velocity and Temperature Distribution” on page 44

“Refrigerant Flow Diagram” on page 45

“Wiring Diagram” on page 46

“Factory Supplied Parts and Materials” on page 47

“Installation and Best Layout Practices” on page 48

ART COOL GALLERY INDOOR UNITS

Mechanical Specifications and Features

MULTI F
MULTI F MAX

ART COOL Gallery Indoor Units

General

All LG indoor units are factory assembled, wired, piped, and provided with a control circuit board, fan, and motor. Art Cool Gallery indoor units have a sound rating no higher than 42 dB(A) as tested per KSA0701 ISO Standard 3745.

Coil

Indoor unit coils are comprised of a minimum of two rows of aluminum fins mechanically bonded to copper tubing. The coils are pressure tested at the factory. Each unit is provided with a factory installed condensate drain pan below the coil.

Refrigerant System

System is designed for use with R410A refrigerant. The refrigeration circuit is pressure-tested at the factory and shipped with a holding charge of helium gas. Refrigerant pipe connections are 45° flare. All refrigerant lines from the outdoor unit to the indoor units must be field insulated.

Electrical

Each indoor unit is designed to operate using 208–230/60/1 power with voltage variances of ±10%.

Casing

Units are designed to mount on a vertical surface, and are shipped with a separate back plate that secures the unit to the wall, protruding no more than six (6) inches. Unit is designed so that refrigerant piping can be installed in one of four different directions.

Cases / Finishes

The Art Cool Gallery unit has a frame that can accommodate a 20" x 20" photograph, picture or artwork. Unit casing has a gray finish and is manufactured of heavy-duty acrylonitrile butadiene styrene (ABS) and high impact polystyrene (HIPS) plastic.

Fan Assembly and Control

The unit has a single, direct-drive, crossflow fan made of high strength ABS plastic. The fan motor is brushless digitally controlled (BLDC) with permanently lubricated and sealed ball bearings. The fan / motor assembly is mounted on vibration attenuating rubber grommets. Fan speed is controlled using a microprocessor-based direct digitally controlled algorithm that provides pre-programmed, field-selectable fixed or auto fan speeds in the Heating and Cooling modes. For Art Cool Gallery units, the indoor fan has Low, Med, High, Power Cool and Auto settings for Cooling mode; and has Low, Med, High, and Auto settings for Heating mode. The Auto setting adjusts the fan speed based on the difference between the controller setpoint and space temperature. Also, the separate Chaos setting provides a simultaneous and random change in fan speed and flow

Features

- Inverter (Variable speed fan)
- Chaos swing
- Jet cool
- Group control
- Self-cleaning indoor coil
- Auto operation / auto restart operation
- 24-Hour on/off timer
- Wireless LCD remote control included; wired thermostat available (sold separately)

direction at the discharge, simulating a natural outdoor breeze.

Air Filter

Return air is filtered with a factory-supplied, removable, washable pre-filter. Filter access is from the front of the unit without the use of tools.

Airflow Guide Vanes

Motorized oscillating guide vanes are factory installed, and allows the ability to control the direction of airflow from side to side. A motorized air sweep louver provides an automatic change in airflow by directing the air up and down to provide uniform air distribution.

Microprocessor Control

The indoor unit is provided with an integrated control panel to communicate with the outdoor unit. All unit operation parameters are stored in non-volatile memory resident on the unit microprocessor. The microprocessor controls space temperature through using the value provided by the temperature sensor within the indoor unit. The microprocessor control will activate indoor unit operation when the indoor room temperature falls below or rises above a setpoint temperature, at which point, a signal is sent to the outdoor unit to begin the appropriate mode. The microprocessor will also provide self-diagnostics and auto restart functions. A field-supplied four-wire power / communications cable must be installed to connect the indoor unit(s) to the outdoor unit.

Controls

The indoor unit casing has a factory-standard, integral infrared sensor designed to communicate with the supplied LG wireless handheld remote controller. An optional LG supplied wired controller is available as an additional accessory. Communication between the indoor units and the outdoor unit is accomplished through 18 AWG, four-core, stranded and shielded power / communication cable.

Condensate

The unit is designed for gravity draining of condensate and includes a flexible drain hose capable of installation in one of two directions. Unit includes a connection that is compatible with the AquaGuard® AG-9300-LG condensate sensor.

Figure 40: Multi F Art Cool Gallery Indoor Unit.



Table 21: Multi F Art Cool Gallery Indoor Unit General Data.

Model Name	LMAN097HVP	LMAN127HVP
Nominal Cooling Capacity (Btu/h) ¹	9,000	11,200
Nominal Heating Capacity (Btu/h) ¹	10,400	13,300
<i>Operating Range</i>		
Cooling (°F WB)	57-77	57-77
Heating (°F DB)	59-81	59-81
<i>Fan</i>		
Type	Turbo	Turbo
Motor Output (W) x Qty.	24 x 1	24 x 1
Motor/Drive	Brushless Digitally Controlled / Direct	Brushless Digitally Controlled / Direct
Airflow Rate CFM (H/M/L)	272 / 208 / 155	314 / 258 / 198
<i>Unit Data</i>		
Refrigerant Type ²	R410A	R410A
Refrigerant Control	EEV	EEV
Power Supply V, Ø, Hz ³	208-230, 1, 60	208-230, 1, 60
Rated Amps (A)	0.2	0.2
Sound Pressure Level ±3 dB(A) (H/M/L) ⁴	39 / 35 / 31	42 / 38 / 34
Dimensions (W x H x D, in.)	23-5/8 x 23-5/8 x 5-25/32	23-5/8 x 23-5/8 x 5-25/32
Net Unit Weight (lbs.)	32	32
Shipping Weight (lbs.)	37	37
Power Wiring / Communications Cable (No. x AWG) ⁵	4 x 18	4 x 18
Heat Exchanger (Row x Column x Fin / inch) x Number	(2 x 20 x 21) x 1	(2 x 20 x 21) x 1
<i>Piping</i>		
Liquid (in.)	1/4	1/4
Vapor (in.)	3/8	3/8
Drain O.D. / I.D. (in.)	27/32, 5/8	27/32, 5/8

¹Nominal capacity is rated 0 ft. above sea level with corresponding refrigerant piping length in accordance with standard length of each outdoor unit and a 0 ft. level difference between outdoor and indoor units. All capacities are net with a combination ratio between 95 – 105%.

Nominal cooling capacity rating obtained with air entering the indoor unit at 80°F dry bulb (DB) and 67°F wet bulb (WB) and outdoor ambient conditions of 95°F dry bulb (DB) and 75°F wet bulb (WB).

Nominal heating capacity rating obtained with air entering the indoor unit at 70°F dry bulb (DB) and 60°F wet bulb (WB) and outdoor ambient conditions of 47°F dry bulb (DB) and 43°F wet bulb (WB).

²This unit comes with a dry helium charge.

³Acceptable operating voltage: 187V-253V.

⁴Sound pressure levels are tested in an anechoic chamber under ISO Standard 3745 and are the same in both cooling and heating mode. These values can increase due to ambient conditions during operation.

⁵All power wiring / communications cable to be minimum 18 AWG, 4-conductor, stranded, shielded, and must comply with applicable local and national codes.

ART COOL GALLERY INDOOR UNITS

Dimensions

MULTI F
MULTI F MAX

Figure 41: LMAN097HVP and LMAN127HVP Dimensions.

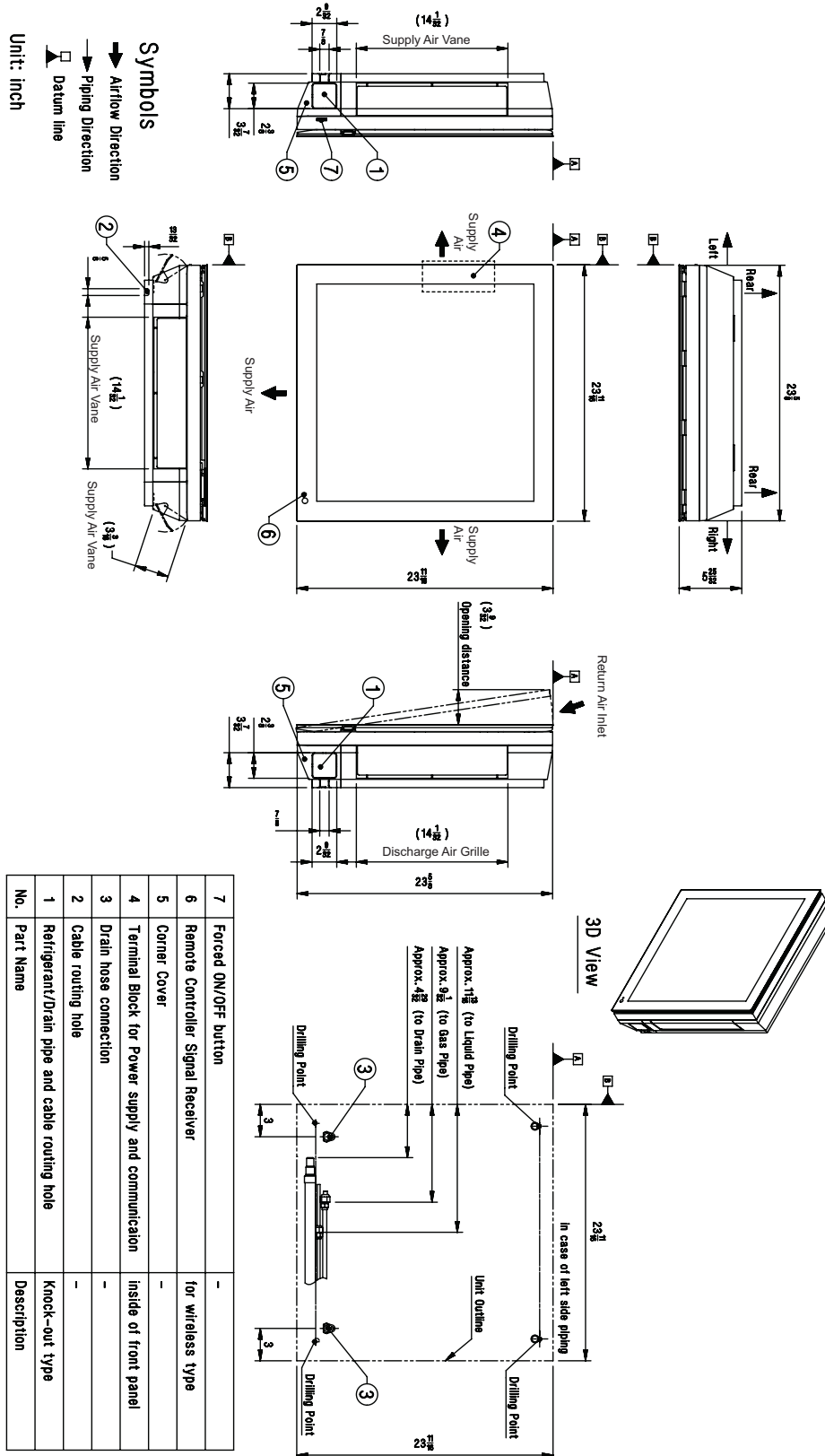


Table 22: Multi F Art Cool Gallery Indoor Units Cooling Capacity Table.

Model No. / Nominal Capacity of Indoor Unit (Btu/h)	Outdoor Air Temp. (°F DB)	Indoor Air Temp. °F DB / °F WB											
		68 / 57		73 / 61		77 / 64		80 / 67		86 / 72		90 / 75	
		TC	SHC	TC	SHC	TC	SHC	TC	SHC	TC	SHC	TC	SHC
LMAN097HVP 9,000	14	8.82	5.68	9.37	6.00	9.92	5.81	10.31	5.93	11.01	5.98	11.56	6.09
	20	8.82	5.72	9.36	6.04	9.91	5.85	10.31	5.98	11.01	6.03	11.55	6.14
	25	8.81	5.77	9.36	6.09	9.90	5.90	10.30	6.02	11.00	6.07	11.54	6.19
	30	8.80	5.81	9.35	6.14	9.90	5.94	10.29	6.07	10.99	6.12	11.54	6.23
	35	8.80	5.85	9.34	6.18	9.89	5.99	10.28	6.11	10.98	6.17	11.53	6.28
	40	8.79	5.90	9.33	6.23	9.88	6.03	10.27	6.16	10.97	6.21	11.52	6.33
	45	8.78	5.94	9.33	6.28	9.87	6.08	10.27	6.21	10.96	6.26	11.51	6.38
	50	8.78	5.99	9.32	6.32	9.87	6.12	10.26	6.25	10.96	6.30	11.50	6.42
	55	8.77	6.03	9.31	6.37	9.86	6.17	10.25	6.30	10.95	6.35	11.49	6.47
	60	8.76	6.07	9.31	6.42	9.85	6.21	10.24	6.34	10.94	6.40	11.48	6.52
	65	8.76	6.12	9.30	6.46	9.84	6.26	10.24	6.39	10.93	6.44	11.47	6.56
	70	8.75	6.16	9.29	6.51	9.84	6.30	10.23	6.43	10.92	6.49	11.47	6.61
	75	8.54	6.06	9.08	6.41	9.62	6.21	10.01	6.35	10.71	6.41	11.25	6.54
	80	8.33	5.96	8.87	6.31	9.41	6.12	9.80	6.26	10.49	6.33	11.03	6.46
	85	8.12	5.85	8.66	6.20	9.20	6.03	9.59	6.17	10.28	6.24	10.82	6.38
	90	7.91	5.74	8.45	6.09	8.99	5.93	9.37	6.07	10.06	6.16	10.60	6.30
	95	7.68	5.68	8.22	6.04	8.75	5.88	9.00	5.94	9.83	6.12	10.36	6.27
	100	7.50	5.52	8.03	5.89	8.57	5.74	8.88	5.85	9.64	5.99	10.17	6.14
105	7.31	5.37	7.84	5.73	8.38	5.60	8.77	5.76	9.45	5.86	9.99	6.01	
110	7.12	5.19	7.66	5.55	8.19	5.43	8.58	5.58	9.26	5.69	9.80	5.85	
115	6.94	5.03	7.47	5.39	8.01	5.29	8.39	5.44	9.08	5.56	9.61	5.71	
118	6.82	5.00	7.36	5.36	7.89	5.26	8.28	5.42	8.96	5.54	9.50	5.70	
122	6.79	4.98	7.32	5.35	7.86	5.25	8.24	5.41	8.93	5.53	9.46	5.69	
LMAN127HVP 12,000	14	10.98	7.06	11.66	7.46	12.34	7.22	12.84	7.38	13.71	7.44	14.39	7.58
	20	10.97	7.12	11.65	7.52	12.33	7.28	12.83	7.43	13.70	7.50	14.38	7.64
	25	10.96	7.17	11.64	7.58	12.32	7.34	12.82	7.49	13.69	7.55	14.37	7.70
	30	10.95	7.23	11.63	7.64	12.31	7.39	12.81	7.55	13.68	7.61	14.36	7.76
	35	10.95	7.28	11.63	7.69	12.31	7.45	12.80	7.61	13.66	7.67	14.34	7.82
	40	10.94	7.34	11.62	7.75	12.30	7.51	12.79	7.66	13.65	7.73	14.33	7.87
	45	10.93	7.39	11.61	7.81	12.29	7.56	12.78	7.72	13.64	7.79	14.32	7.93
	50	10.92	7.45	11.60	7.87	12.28	7.62	12.77	7.78	13.63	7.84	14.31	7.99
	55	10.91	7.50	11.59	7.92	12.27	7.67	12.76	7.83	13.62	7.90	14.30	8.05
	60	10.90	7.56	11.58	7.98	12.26	7.73	12.75	7.89	13.61	7.96	14.29	8.11
	65	10.90	7.61	11.57	8.04	12.25	7.78	12.74	7.95	13.60	8.02	14.28	8.17
	70	10.89	7.67	11.56	8.10	12.24	7.84	12.73	8.01	13.59	8.07	14.27	8.23
	75	10.63	7.54	11.30	7.97	11.97	7.73	12.46	7.90	13.32	7.97	14.00	8.13
	80	10.36	7.41	11.04	7.85	11.71	7.62	12.19	7.79	13.05	7.87	13.73	8.04
	85	10.10	7.27	10.77	7.72	11.45	7.50	11.93	7.67	12.79	7.77	13.46	7.94
	90	9.84	7.14	10.51	7.58	11.18	7.38	11.67	7.56	12.52	7.66	13.19	7.83
	95	9.56	7.06	10.23	7.51	10.89	7.32	11.20	7.39	12.23	7.62	12.89	7.80
	100	9.33	6.87	10.00	7.32	10.66	7.15	11.05	7.28	11.99	7.45	12.66	7.64
105	9.10	6.68	9.76	7.13	10.43	6.97	10.91	7.16	11.76	7.29	12.43	7.48	
110	8.86	6.46	9.53	6.90	10.20	6.76	10.68	6.95	11.53	7.08	12.19	7.27	
115	8.63	6.26	9.30	6.71	9.96	6.58	10.44	6.77	11.30	6.91	11.96	7.11	
118	8.49	6.22	9.16	6.67	9.82	6.54	10.30	6.74	11.16	6.89	11.82	7.09	
122	8.44	6.20	9.11	6.65	9.78	6.53	10.26	6.73	11.11	6.88	11.78	7.08	

TC = Total Capacity (kBtu/h).

SHC: Sensible Heat Capacity (kBtu/h).

Nominal capacity as rated 0 ft. above sea level and a 0 ft. level difference between outdoor and indoor units. Corresponding refrigerant piping length is accordance with standard length of each outdoor unit.

Nominal cooling capacity rating obtained with air entering the indoor unit at 80°F dry bulb (DB) and 67°F wet bulb (WB), and outdoor ambient conditions of 95°F dry bulb (DB) and 75°F wet bulb (WB).

The shaded table columns and rows indicate reference data. When operating at this temperature, these values can be different if the system is not running consistently.

ART COOL GALLERY INDOOR UNITS

Heating Capacity Table

MULTI F
MULTI F MAX

Table 23: Multi F Art Cool Gallery Indoor Units Heating Capacity Table.

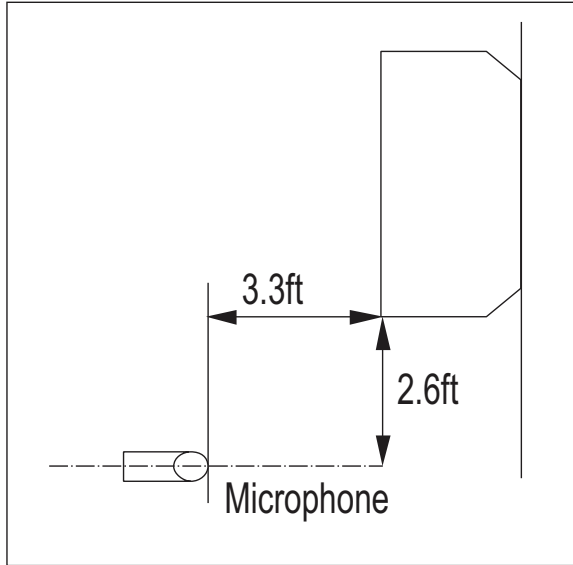
Model No. / Nominal Capacity of Indoor Unit (Btu/h)	Outdoor Air Temp.		Indoor Air Temp. °F DB					
	°F DB	°F WB	61	64	68	70	72	75
			TC	TC	TC	TC	TC	TC
LMAN097HVP 9,000	0	-0.4	5.35	5.28	5.23	5.20	5.12	4.90
	5	4.5	6.03	5.95	5.90	5.88	5.80	5.58
	10	9	6.71	6.63	6.58	6.56	6.48	6.26
	17	15	7.61	7.54	7.49	7.46	7.39	7.14
	20	19	7.95	7.88	7.83	7.80	7.72	7.46
	25	23	8.52	8.44	8.39	8.37	8.29	7.99
	30	28	9.01	8.93	8.88	8.86	8.78	8.52
	35	32	9.50	9.42	9.37	9.34	9.27	9.04
	40	36	9.94	9.86	9.81	9.78	9.71	9.48
	45	41	10.37	10.30	10.25	10.22	10.15	9.92
	47	43	10.55	10.48	10.43	10.40	10.32	10.10
	50	46	10.72	10.64	10.59	10.57	10.49	10.24
	55	51	11.00	10.93	10.88	10.85	10.78	10.48
	60	56	11.00	10.93	10.88	10.85	10.78	10.52
	63	59	11.00	10.93	10.88	10.85	10.78	10.55
68	64	11.00	10.93	10.88	10.85	10.78	10.60	
LMAN127HVP 12,000	0	-0.4	6.84	6.75	6.68	6.65	6.55	6.26
	5	4.5	7.71	7.61	7.55	7.52	7.42	7.13
	10	9	8.58	8.48	8.42	8.38	8.29	8.00
	17	15	9.73	9.64	9.57	9.54	9.44	9.14
	20	19	10.17	10.07	10.01	9.98	9.88	9.54
	25	23	10.89	10.79	10.73	10.70	10.60	10.22
	30	28	11.52	11.42	11.36	11.32	11.23	10.89
	35	32	12.14	12.05	11.98	11.95	11.85	11.57
	40	36	12.71	12.61	12.55	12.51	12.42	12.13
	45	41	13.27	13.17	13.11	13.08	12.98	12.69
	47	43	13.49	13.40	13.33	13.30	13.20	12.91
	50	46	13.71	13.61	13.55	13.52	13.42	13.10
	55	51	14.07	13.97	13.91	13.88	13.78	13.40
	60	56	14.07	13.97	13.91	13.88	13.78	13.46
	63	59	14.07	13.97	13.91	13.88	13.78	13.49
68	64	14.07	13.97	13.91	13.88	13.78	13.55	

TC = Total Capacity (kBtu/h).

Nominal capacity as rated 0 ft. above sea level and a 0 ft. level difference between outdoor and indoor units. Corresponding refrigerant piping length is accordance with standard length of each outdoor unit.

Nominal heating capacity rating obtained with air entering the indoor unit at 70°F dry bulb (DB) and 60°F wet bulb (WB), and outdoor ambient conditions of 47°F dry bulb (DB) and 43°F wet bulb (WB).

Figure 42: Sound Pressure Level Measurement Location.

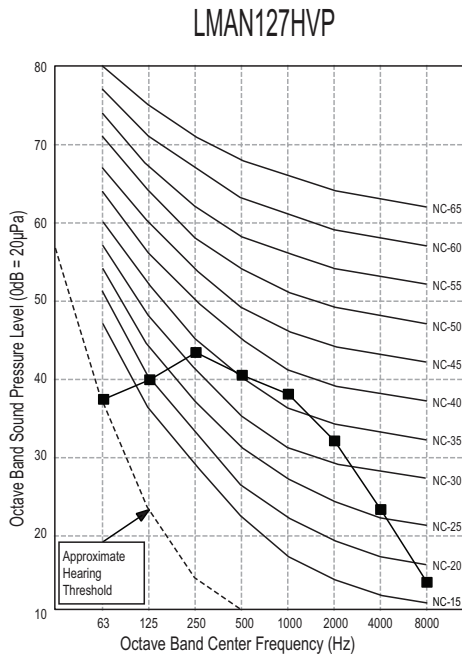
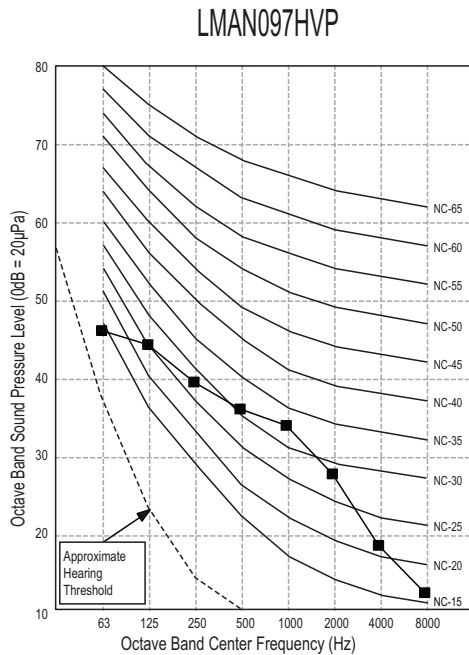


- Measurement taken 2.6' below the bottom of the unit and at a distance of 3.3' from face of unit.
- Measurements taken with no attenuation and units operating at full load normal operating condition.
- Sound level will vary depending on a range of factors such as construction (acoustic absorption coefficient) of particular area in which the equipment is installed.
- Sound power levels are measured in dB(A)±3.
- Tested in anechoic chamber per ISO Standard 3745.

Table 24: Sound Pressure Levels (dB[A]).

Model No.	Sound Pressure Levels (dB[A]) (Cooling and Heating)		
	High Fan Speed	Medium Fan Speed	Low Fan Speed
LMAN097HVP	39	35	31
LMAN127HVP	42	38	34

Figure 43: Sound Pressure Level Diagrams.



ART COOL GALLERY INDOOR UNITS

Air Velocity and Temperature Distribution

MULTI F
MULTI F MAX

Figure 44: LMAN097HVP Air Velocity and Temperature Distribution Charts.

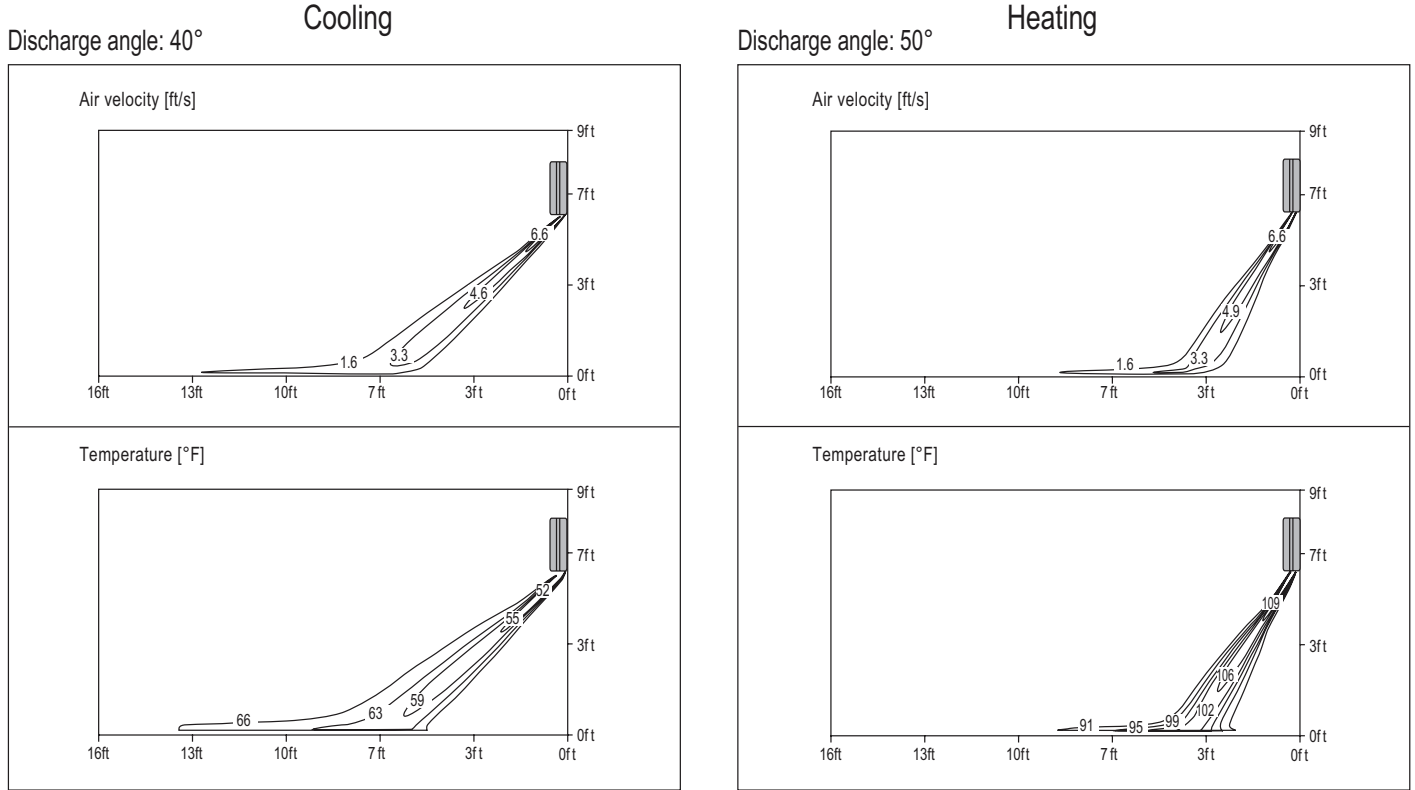


Figure 45: LMAN127HVP Air Velocity and Temperature Distribution Charts.

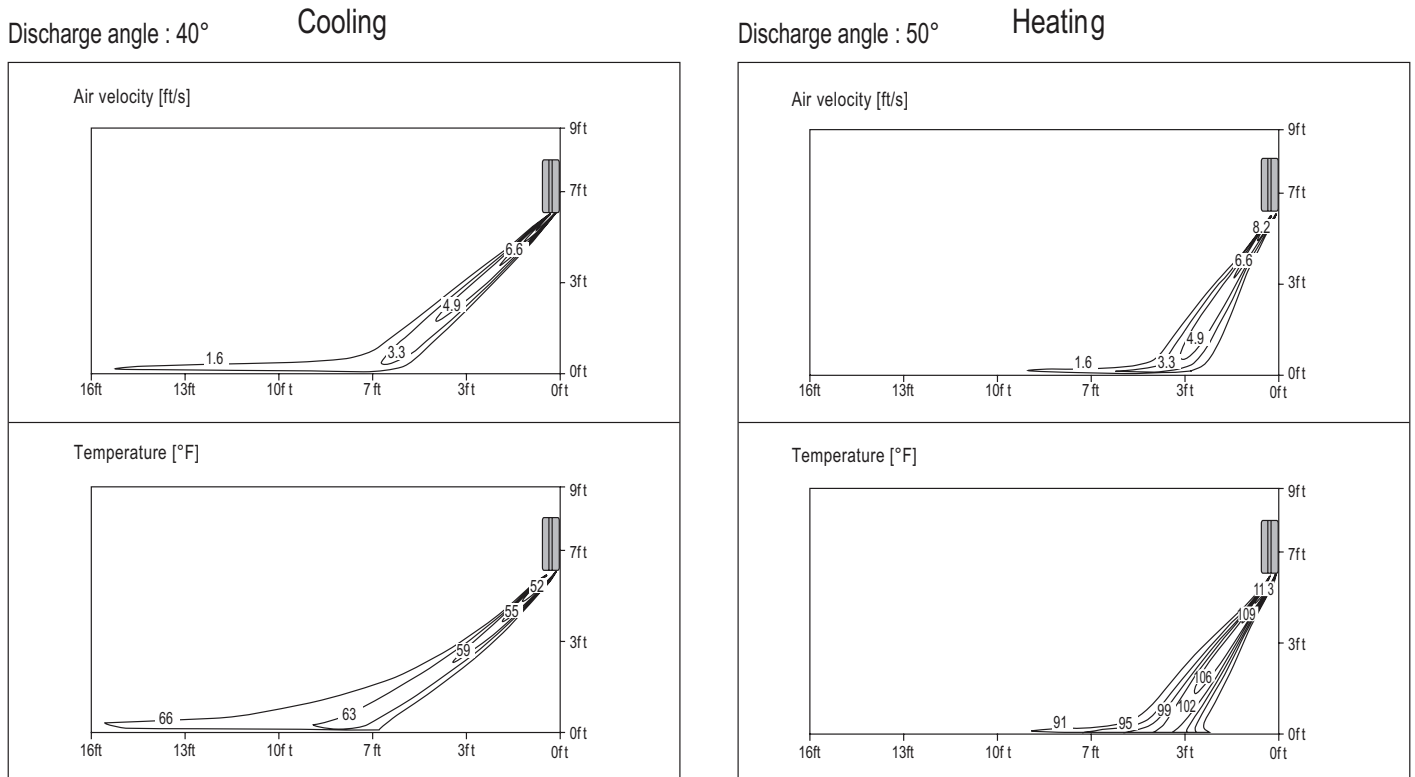


Figure 46: Art Cool Gallery Indoor Unit Refrigerant Flow Diagram.

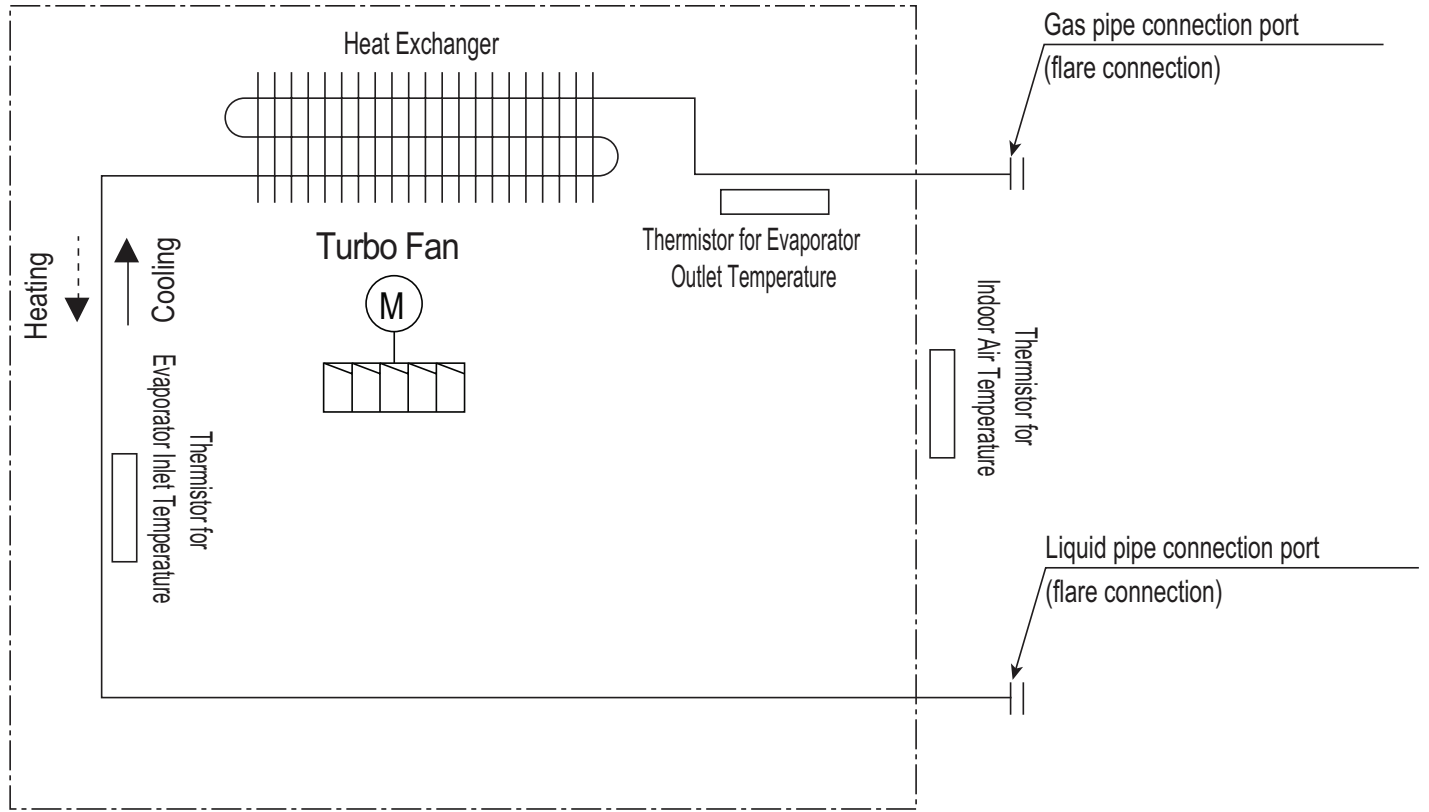


Table 25: Art Cool Gallery Indoor Unit Refrigerant Pipe Connection Port Diameters.

Model No.	Vapor (inch)	Liquid (inch)
LMAN097HVP	Ø3/8	Ø1/4
LMAN127HVP		

Table 26: Art Cool Gallery Indoor Unit Thermistor Details.

Description (Based on Cooling Mode)	PCB Connector
Indoor Air Temperature Thermistor	CN-TH1
Evaporator Inlet Temperature Thermistor	
Evaporator Outlet Temperature Thermistor	CN-TH2
Water Level Sensor (Optional)	CN-TH3

ART COOL GALLERY INDOOR UNITS

Wiring Diagram

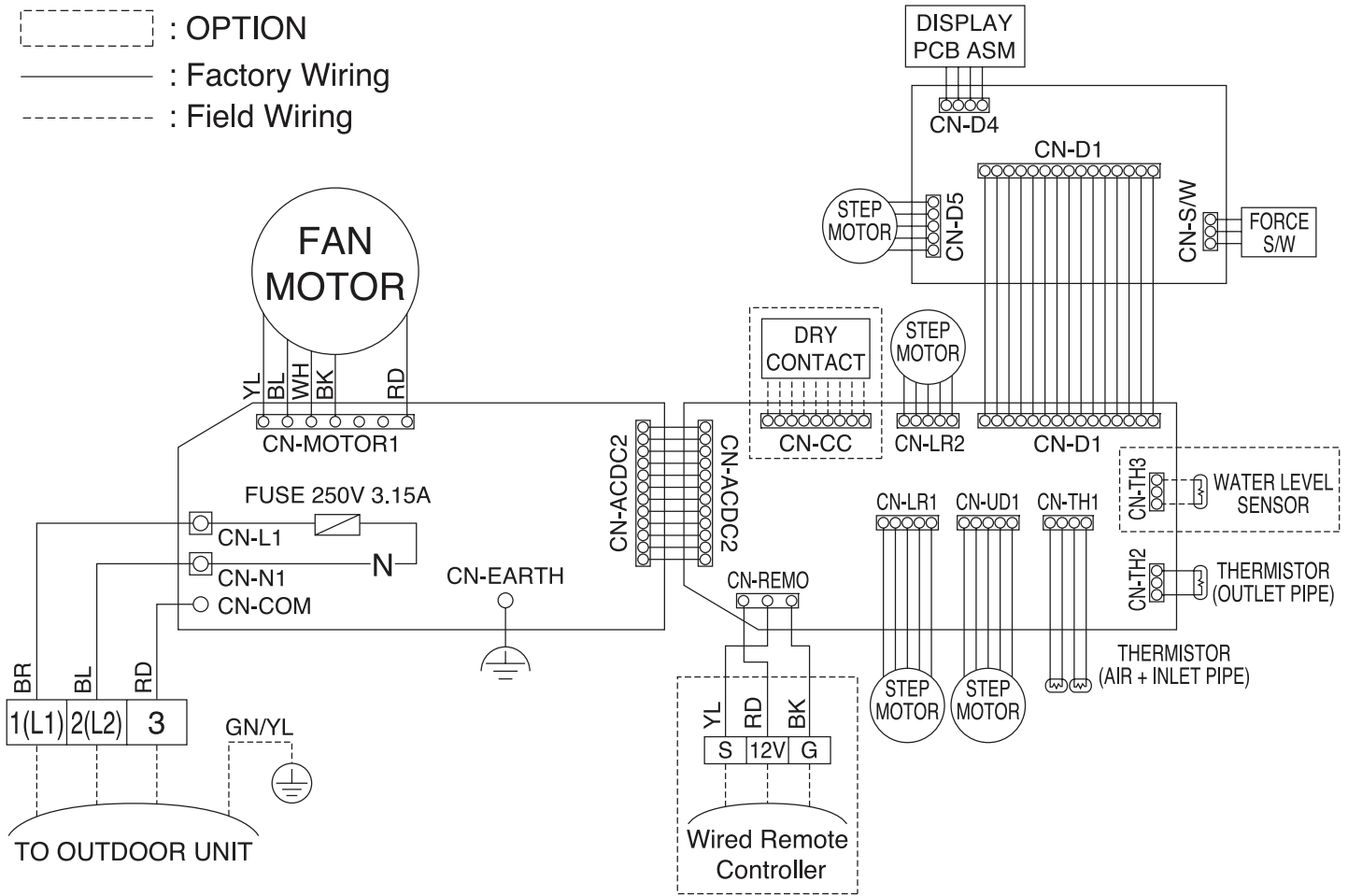
MULTI F
MULTI F MAX

Figure 47: Multi F Art Cool Gallery Indoor Units Wiring Diagram.

--- : OPTION

— : Factory Wiring

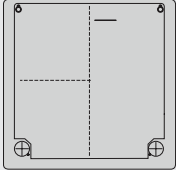
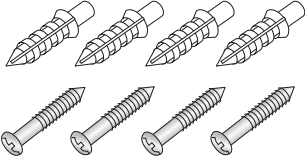
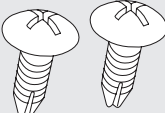

- - - : Field Wiring



Multi F and Multi F MAX Indoor Unit Engineering Manual

Factory Supplied Parts

Table 27: Parts Table.

Part	Quantity	Image
Installation Guide	One (1)	
Type "A" Screws and Plastic Anchors	Four (4) Each	
Type "B" Screws (M4 x 12L)	Two (2)	
Wireless Handheld Controller with Holder (AKB73635607)	One (1)	

Factory Supplied Materials

- Owner's Manual
- Installation Manual

Required Tools

- Level
- Screwdriver
- Electric drill
- Hole core drill
- Flaring tool set
- Spanner (Half union)
- Thermometer

WARNING

- Read all instructions before installing the product.
- Installation work must be performed by authorized personnel and in accordance with the national wiring standards and all local codes.

ART COOL GALLERY INDOOR UNITS

Installation and Best Layout Practices

MULTI F
MULTI F MAX

Selecting the Best Location

Do's

- Place the unit where air circulation will not be blocked.
- Place the unit where drainage can be obtained easily.
- Place the unit where noise prevention is taken into consideration.
- Ensure there is sufficient space from the ceiling and floor.
- Ensure there is sufficient maintenance space.
- Locate the indoor unit in a location where it can be easily connected to the outdoor unit / branch distribution unit.

⚠ WARNING

Don'ts

- The unit should not be installed near a heat or steam source, or where considerable amounts of oil, iron powder, or flour are used.
- The unit should not be installed where sulfuric acid and flammable or corrosive gases are generated, vented into, or stored.
- Avoid installing the unit near high-frequency generators.
- Do not install the unit near a doorway.

The unit may be damaged, may malfunction, and / or will not operate as designed if installed in any of the conditions listed.

Installing in an Area Exposed to Unconditioned Air

In some installation applications, areas (floors, walls) in some rooms may be exposed to unconditioned air (room may be above or next to an unheated garage or storeroom). To countermeasure:

- Verify that carpet is or will be installed (carpet may increase the temperature by three degrees).
- Add insulation between the floor joists.
- Install radiant heat or another type of heating system to the floor.

Using the Installation Guide

1. Choose an appropriate location for the indoor unit. To hang the installation guide, verify that it is level and plumb, and then tape it to the wall.
2. Drill four (4) 1/4-inch diameter holes with a depth of 1-3/16 to 1-3/8 inches for the mounting screws. Drill one (1) two (2) inch-diameter hole for the field-installed refrigerant and drain piping.
3. Insert a plastic anchor into each of the mounting holes.
4. Screw the top two (2) screws into the wall. Do not flush them to the wall; leave a 7/16 inch space for hanging the indoor unit.

⚠ WARNING

If the unit is installed near a body of water, certain components are at risk of being corroded. Appropriate anti-corrosion methods should be taken for the unit and all components.

Figure 48: Minimum Clearance Requirements.

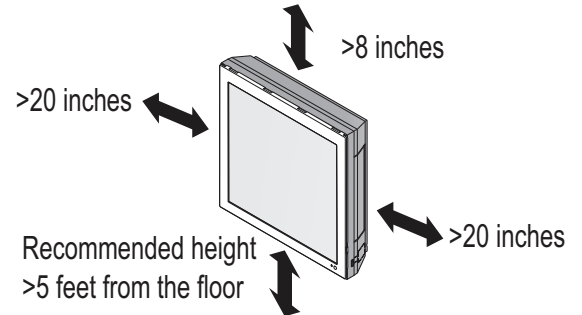
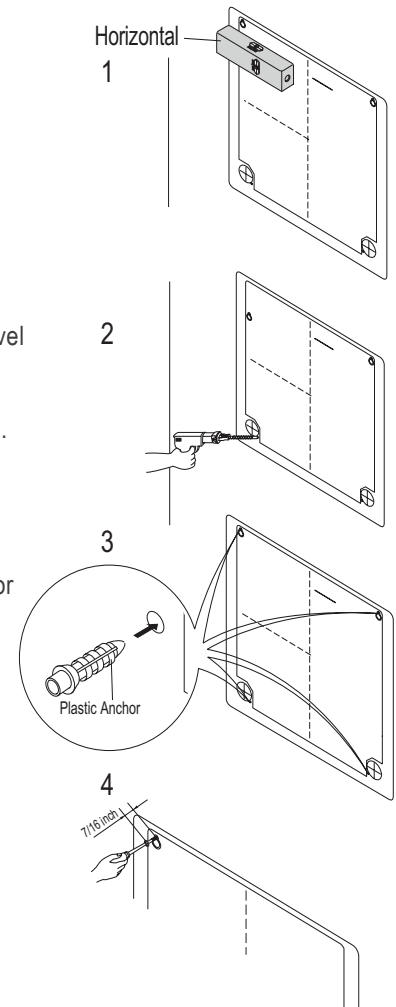


Figure 49: Using the Installation Guide.

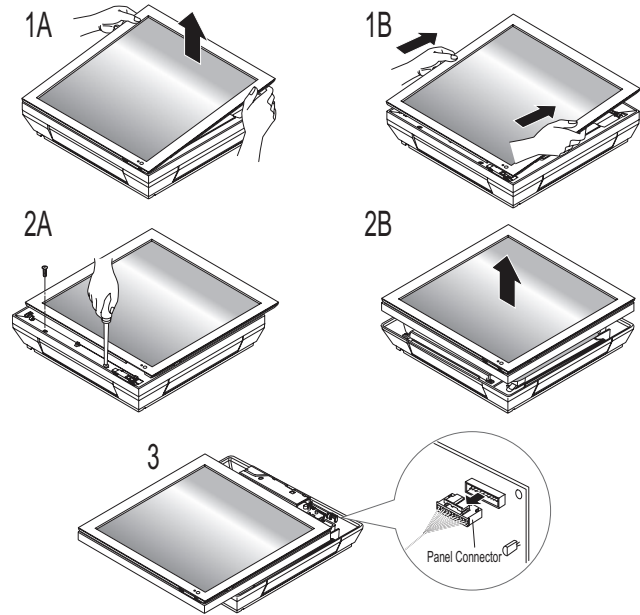


Preparing the Indoor Unit for Installation

Removing the Front Panel

1. First pull the top of the front panel up (1A) and then out (1B).
2. Remove the two (2) screws at the bottom (2A), then lift off the front panel (2B).
3. To completely detach the front panel, disconnect the panel connector found at the top of the indoor unit (3).

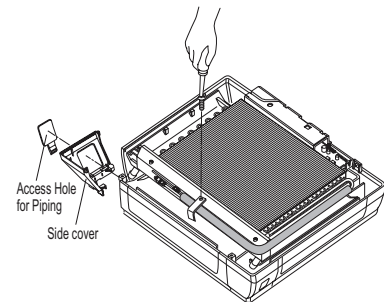
Figure 50: Preparing for Installation.



Removing the Piping and Side Covers

1. Unscrew the center cover.
2. Remove the cover from the side of the indoor unit chosen for the piping connections, and then knock out the piping access hole. If the refrigerant piping will be connected through the back of the unit, the access hole does not need to be knocked out.
3. Remove any burrs that may have been made.

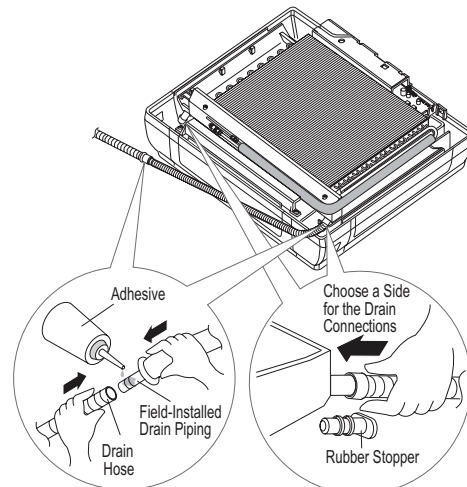
Figure 51: Removing the Piping and Side Covers.



Preparing the Drain Hose

1. Remove the rubber stopper from the chosen side of the indoor unit.
2. Insert the drain hose into the handle of the drain pan.
3. Connect the drain hose to the field-installed drain piping.

Figure 52: Preparing the Drain Hose.



ART COOL GALLERY INDOOR UNITS

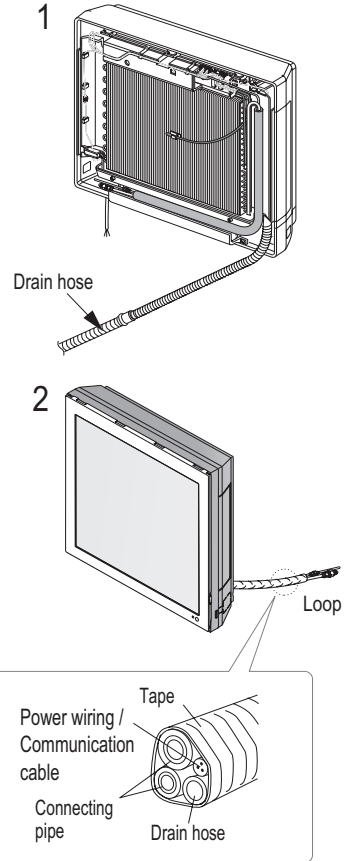
Installation and Best Layout Practices

MULTI F
MULTI F MAX

Preparing the Refrigerant and Drain Piping Connections

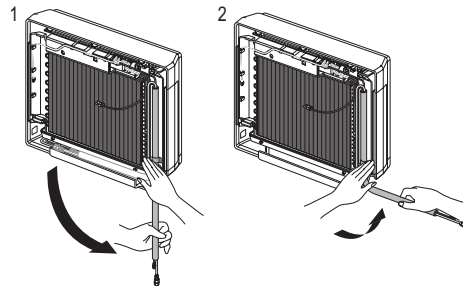
1. Depending on the installation requirements, route the indoor unit refrigerant piping and the drain hose to the left, right (see guidelines below), or rear of the frame.
2. Bundle the piping and drain hose with tape where they meet near the indoor unit frame. Position the drain hose at the bottom of the bundle (positioning the drain hose at the top of the bundle may cause the drain pan to overflow inside the indoor unit).

Figure 53: Preparing the Refrigerant / Drain Connections.



Installing Piping on the Right Side of the Indoor Unit Frame

1. Press on the top of the clamp, and then slowly guide the piping downward. **Figure 54: Right Side Piping Access.**
2. Bend the piping to the right side of the indoor unit frame.



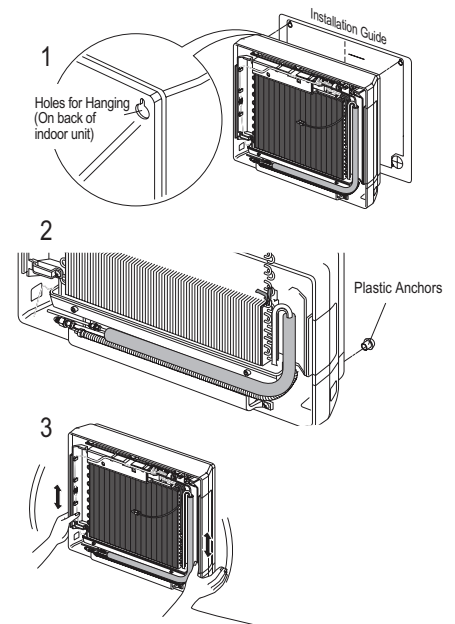
Note:

Do not bend the piping / drain hose from side to side, it may damage the components.

Hanging the Indoor Unit Frame

1. Remove the installation guide and hang the indoor unit on the top two (2) screws. Verify the indoor unit is hanging securely on the screws.
2. Align the holes at the bottom of the indoor unit to the mounting holes. Tighten first the top screws, then tighten the bottom screws.
3. Verify that the indoor unit is completely secured to the wall by gently shaking it up and down.

Figure 55: Hanging the Indoor Unit Frame.



Connecting the Indoor Unit Piping to the Field-Installed Piping

1. Center align the indoor unit piping (refrigerant and drain) and the field-installed piping, then hand tighten the flare nut.
2. Tighten the flare nut with a torque wrench.
3. Attach the drain tube piping to the indoor unit drain hose as shown below.

Figure 56: Indoor Unit to Field-Installed Piping Connection.

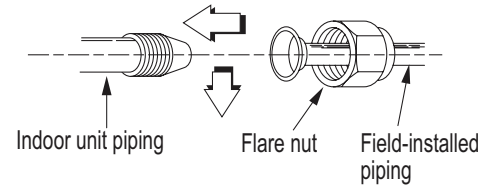
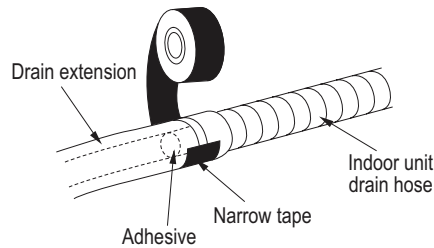
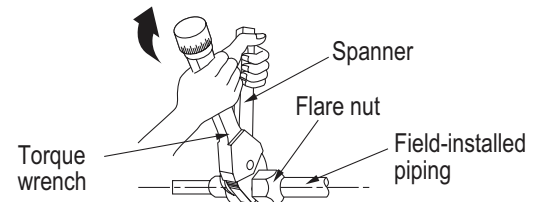


Figure 57: Extending the Drain Hose.



Note:

If the drain hose is routed inside a room, add insulation to prevent condensation from forming.

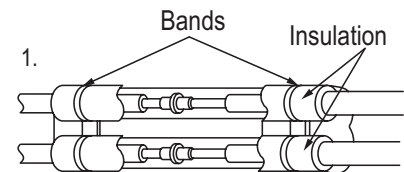


Insulating the Refrigerant and Drain Piping

Refrigerant Piping Insulation

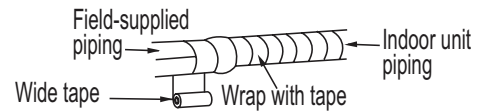
Field-installed vapor and liquid refrigerant piping lines must be properly and completely covered in insulation (up to the indoor unit piping connections). Any exposed piping may generate condensate or will cause burns if touched. Insulation for this field-installed refrigerant piping must have a minimum heat resistance of 248°F.

Figure 58: Insulating the Piping.



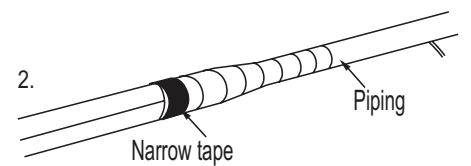
Drain Piping Insulation

Drain piping must have insulation a minimum of 7/32 inches thick.



Installing the Insulation

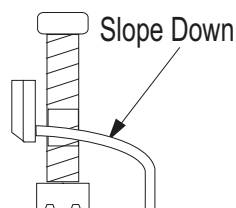
1. Overlap the insulation at the connection of the field-installed piping and the indoor unit piping. Tape together so that no gaps exist.
2. Secure insulation to the rear piping housing section with vinyl tape.
3. Bundle the piping and drain hose with tape where they meet at the back of the indoor unit frame. Position the drain hose at the bottom of the bundle (positioning the drain hose at the top of the bundle may cause the drain pan to overflow inside the indoor unit).



Drain Slope

Drain hose should point down so water can flow away easily.

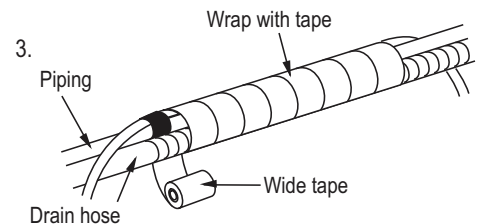
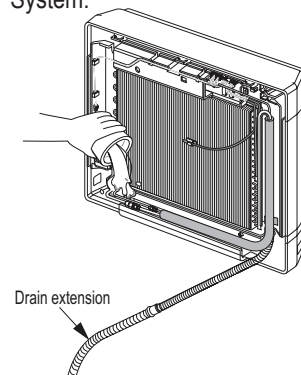
Figure 59: Drain Piping Slope.



Checking the Drainage System

1. Pour water on the indoor unit evaporator.
2. Ensure the water flows through and out of the hose and away from the indoor unit without leaking.

Figure 60: Checking the Drainage System.



ART COOL GALLERY INDOOR UNITS

Installation and Best Layout Practices

MULTI F
MULTI F MAX

Power Wiring / Communications Cable Guidelines

- Follow manufacturer's circuit diagrams in the technical manuals.
- Confirm power source specifications.
- Confirm that the electrical capacity is sufficient.
- Starting current must be maintained ± 10 percent of the rated current marked on the outdoor unit name plate.
- Confirm cable thickness specifications.
- It is recommended that a circuit breaker is installed, especially if conditions could become wet or moist.
- Include a disconnect in the power wiring system, add an air gap contact separation of at least 1/8 inch in each active (phase) conductor.

⚠ WARNING

- Loose wiring may cause unit malfunction, or the terminal to overheat and catch fire.
- Terminal screws may become loose during transport. Properly tighten the terminal connections during installation.

A voltage drop may cause the following problems:

- Magnetic switch vibration, fuse breaks, or disturbance to the normal function of an overload protection device.
- Compressor will not receive the proper starting current.

Connecting the Power Wiring and Communications Cable

1. Insert the power wiring / communications cable from the outdoor unit or branch distribution unit (Multi F MAX systems only) through the access hole of the indoor unit (ground wire should be longer than the other wires / cables). Unscrew the control board cover.
2. Connect each wire to its appropriate terminal on the indoor unit control board. Verify that the color and terminal numbers from the outdoor unit or branch distribution unit (Multi F MAX systems only) wiring match the color and terminal numbers on the indoor unit.
3. Secure the power wiring / communications cable to the control board.
4. Reattach the control board cover.

Figure 61: Connecting the Power Wiring / Communications Cable.

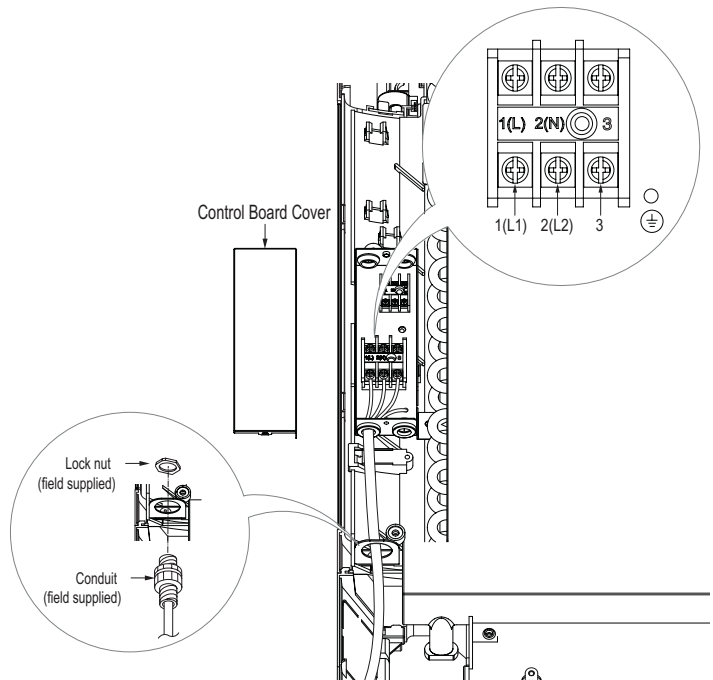
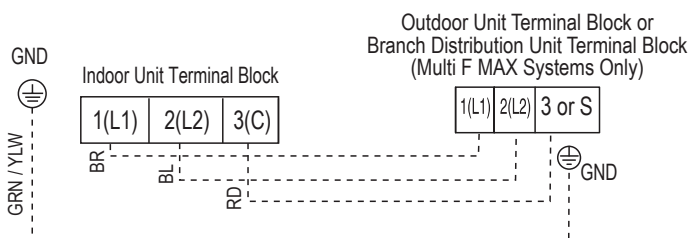


Figure 62: Simplified View of Indoor Unit to Outdoor Unit / Branch Distribution Unit Terminal Connections—LMAN097HVP and LMAN127HVP models.



Controller Options

Art Cool Gallery wall-mounted indoor units include a handheld controller (AKB73635607), but optional LG-supplied wired controllers are available (see Controls and Options overview on pages 9 to 12 in this manual's Introduction section).

Wireless Handheld Controller

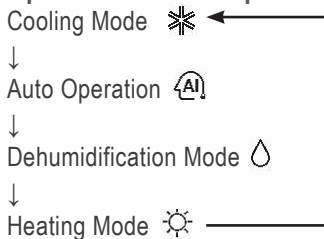
Figure 63:AKB73635607 Wireless Controller.



Table 28: AKB73635607 Wireless Controller Functions.

Control Panel Button	Display Screen	Description
FAN		Air circulation button ¹ : Circulates the room air without operating in cooling or heating mode.
SLEEP		Sleep Mode Auto Button ¹ : Sets the sleep mode auto operation.
TEMP		Temperature Adjustment Buttons: Raises or lowers temperature setpoint in cooling and heating operation.
ON/OFF	-	On / Off Button: Turns the power on/off.
FAN SPEED		Indoor Fan Speed Button: Changes the fan speed.
MODE		Operation mode selection button ¹ : Selects the operation mode. Cooling operation / Auto operation or auto changeover / Dehumidifying operation / Heating operation
JET		Jet Cool / Jet Heat Button ¹ : Warms up or cools down the indoor temperature within a short period.
SWING		Air Flow Direction Button: Adjusts the airflow direction.
ROOM TEMP		Temperature Display Button: Displays the room temperature. Press and hold button down for five (5) seconds to change from °C to °F.
ON/OFF		Timer button: Sets the current time and the start / end times.
A/CLEAN, E/SAVING, LIGHT		Navigation / Functions Button ¹ : Adjusts the time and sets the special functions. Auto clean / Operates energy saving cooling / Adjusts the brightness of the indoor unit display
SET CLEAR	-	Set / Clear Button: Sets or cancels functions.
○	-	Reset Button: Resets the air conditioner settings.

Operation Mode Sequence



¹Depending on the indoor unit model, some functions may not be supported.

ART COOL GALLERY INDOOR UNITS

Installation and Best Layout Practices

MULTI F
MULTI F MAX

Multi F and Multi F MAX Indoor Unit Engineering Manual

Wired Controller Connections

Figure 64: Wired Controller Connection on the Indoor Unit Terminal Block.

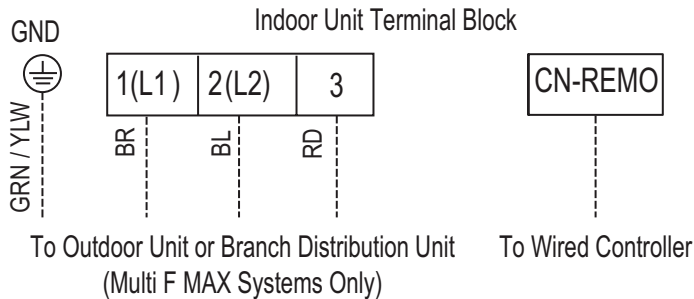
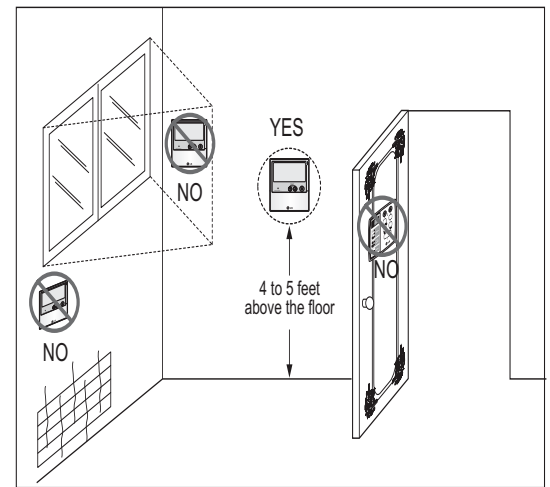


Figure 65: Proper Location for the Wired Controller.



Wired Controller Placement

Wired controllers include a sensor to detect room temperature. To maintain comfort levels in the conditioned space, the wired controller must be installed in a location away from direct sunlight, high humidity, and where it could be directly exposed to cold air. Controller must be installed four (4) to five (5) feet above the floor where its LED display can be read easily, in an area with good air circulation, and where it can detect an average room temperature.

Do not install the wired controller near or in:

- Drafts or dead spots behind doors and in corners
- Hot or cold air from ducts
- Radiant heat from the sun or appliances
- Concealed pipes and chimneys
- An area where temperatures are uncontrolled, such as an outside wall

Hanging the Wired Controller

1. The controller wiring / cable can be installed in one of three directions: top, back, or on the right side. If top or right side installation is desired, remove cable guide grooves on the controller, and then position wiring / cable on applicable side.
2. Choose and mark the area of installation, and then screw the wall plate into place (using the provided parts). Install the controller wall plate to fit the electrical box if one is present. Ensure that no gaps exist between the wall plate and the wall itself.
3. Arrange wiring / cables so as not to interfere with the controller circuitry. Position the wired controller on the wall plate. Snap into place by pressing the bottom part of the wired controller onto the wall plate. Make sure that no gaps exist between the wired controller and the wall plate on all sides.
4. To remove wired controller from the wall plate, insert a screwdriver into the two holes at the bottom. Twist screwdriver to release controller. Do not damage the controller components when removing.

Figure 66: Removing the Cable Guide Grooves.

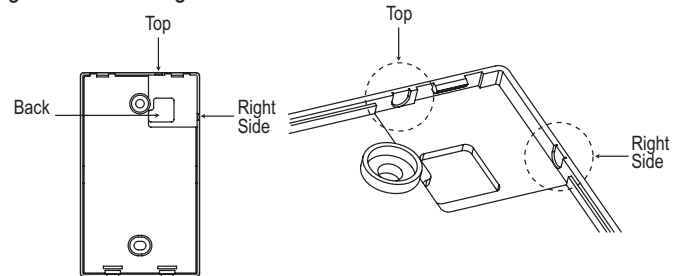


Figure 67: Attaching the Wall Plate.

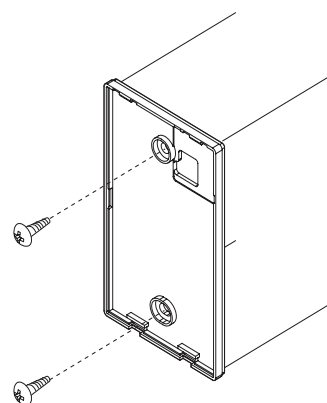
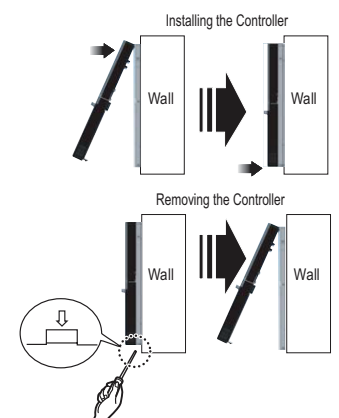


Figure 68: Installing / Removing the Controller.



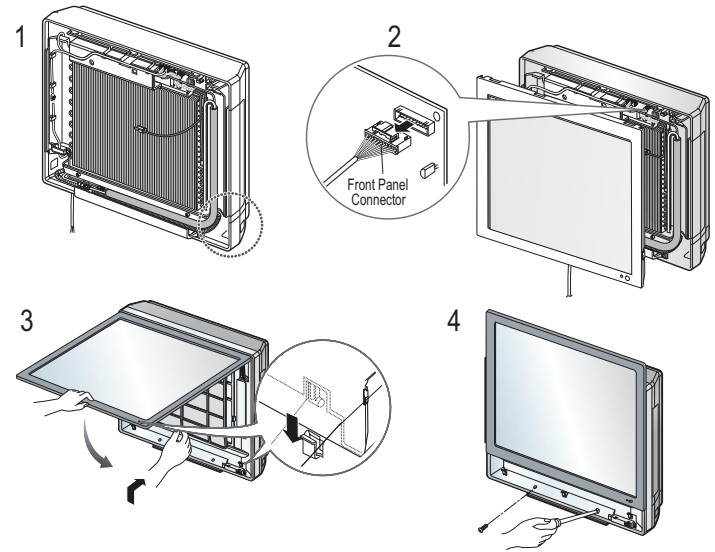
Assigning the Thermistor for Temperature Detection

Each indoor unit includes a return air thermistor assigned to sense the temperature. If a wired controller is installed, there is a choice of sensing temperature with either the indoor unit return air thermistor or the thermistor in the wired controller. It is also an option to set both thermistors to sense temperature so that indoor unit bases its operation on the first thermistor to reach the designated temperature differential. For applicable indoor units, an optional Remote Temperature Sensor can be used in lieu of the return air thermistor—either alone or in conjunction with a wired controller thermistor as previously described.

Finalizing Indoor Unit Installation

1. Verify that the side covers are closed or opened, depending on installation requirements. Place the power wiring / communications cable in the bottom groove along the left side of the frame.
2. Reconnect the panel connector found at the top of the indoor unit.
3. Attach the top part of the front panel, then position its tabs in the grooves on the bottom part of the indoor unit frame.
4. To ensure the front panel tabs are securely positioned in the grooves, adjust the panel by loosening or tightening the screws at the bottom.

Figure 69: Final Installation Step—Reattaching the Front Panel.



STANDARD WALL-MOUNTED INDOOR UNIT DATA

“Mechanical Specifications” on page 58

“General Data / Specifications” on page 59

“Dimensions” on page 60

“Cooling Capacity Table” on page 64

“Heating Capacity Table” on page 67

“Acoustic Data” on page 69

“Air Velocity and Temperature Distribution” on page 71

“Refrigerant Flow Diagram” on page 74

“Wiring Diagram” on page 75

“Factory Supplied Parts and Materials” on page 79

“Installation and Best Layout Practices” on page 80

STANDARD WALL-MOUNTED INDOOR UNITS

Mechanical Specifications and Features

MULTI F
MULTI F MAX

Standard Wall-Mounted Indoor Units

General

All LG indoor units are factory assembled, wired, piped, and provided with a control circuit board, fan, and motor. Standard Wall-Mounted units have a sound rating no higher than 43 dB(A) as tested per KSA0701 ISO Standard 3745.

Coil

Indoor unit coils are comprised of a minimum of two rows of aluminum fins mechanically bonded to copper tubing. The coils are pressure tested at the factory. Each unit is provided with a factory installed condensate drain pan below the coil.

Refrigerant System

System is designed for use with R410A refrigerant. The refrigeration circuit is pressure-tested at the factory and shipped with a holding charge of helium gas. Refrigerant pipe connections are 45° flare. All refrigerant lines from the outdoor unit to the indoor units must be field insulated.

Electrical

Each indoor unit is designed to operate using 208–230/60/1 power with voltage variances of ±10%.

Casing

Units are designed to mount on a vertical surface, and are shipped with a separate back plate that secures the unit to the wall, protruding no more than ten (10) inches. Unit is designed so that refrigerant piping can be installed in one (1) of four (4) different directions.

Finish

The Standard Wall-Mounted unit has a curved architectural panel with a pearl white finish. Unit casing has a pearl white finish and is manufactured of heavy-duty acrylonitrile butadiene styrene (ABS) and high impact polystyrene (HIPS) plastic.

Fan Assembly and Control

The unit has a single, direct-drive, crossflow fan made of high strength ABS plastic. The fan motor is brushless digitally controlled (BLDC) with permanently lubricated and sealed ball bearings. The fan / motor assembly is mounted on vibration attenuating rubber grommets. Fan speed is controlled using a microprocessor-based direct digitally controlled algorithm that provides pre-programmed, field-selectable fixed or auto fan speeds in the Heating and Cooling modes. For Standard Wall-Mounted units, the indoor fan has Low, Med, High, Power Cool and Auto settings for Cooling mode; and has Low, Med, High, and Auto settings for Heating mode. The Auto setting adjusts the fan speed based on the difference between the controller setpoint and space temperature. Also, the separate Chaos setting provides a simultaneous and random change in fan speed

Features

- Inverter (Variable speed fan)
- Chaos swing
- Secondary filter (plasma: HVT; 3M: HSV4)
- Jet cool
- Group control
- Self-cleaning indoor coil
- Auto operation
- Auto restart operation
- Dehumidifying function
- Self diagnosis function
- Wireless LCD remote control included; wired thermostat available (sold separately)

Figure 70: Multi F Standard Wall-Mounted Indoor Unit.



and flow direction at the discharge, simulating a natural outdoor breeze.

Air Filter

Return air inlet has a factory-supplied primary removable, washable filter. The unit is also equipped with a secondary filter. Filters are accessed from the front of the unit without the use of tools.

Airflow Guide Vanes

A motorized guide vane is factory installed, and allows the ability to control the direction of airflow from side to side. A motorized louver provides an automatic change in airflow by directing the air up and down to provide uniform air distribution.

Microprocessor Control

The indoor unit is provided with an integrated control panel to communicate with the outdoor unit. All unit operation parameters are stored in non-volatile memory resident on the unit microprocessor. The microprocessor controls space temperature through using the value provided by the temperature sensor within the indoor unit. The microprocessor control will activate indoor unit operation when the indoor room temperature falls below or rises above a setpoint temperature, at which point, a signal is sent to the outdoor unit to begin the appropriate mode. The microprocessor will also provide self-diagnostics and auto restart functions. A field-supplied four-wire power / communications cable must be installed to connect the indoor unit(s) to the outdoor unit.

Controls

The indoor unit casing has a factory-standard, integral infrared sensor designed to communicate with the supplied LG wireless handheld remote controller. An optional LG supplied wired controller is available as an additional accessory. Communication between the indoor units and the outdoor unit is accomplished through 18 AWG, four-core, stranded and shielded power / communication cable.

Condensate

The unit is designed for gravity draining of condensate and includes a flexible drain hose capable of installation in one of two directions. Unit includes a connection that is compatible with the AquaGuard® AG-9300-LG condensate sensor.

Table 29: Multi F Standard Wall-Mounted Indoor Unit General Data.

Model Name	LMN077HVT	LSN090HSV4	LSN120HSV4	LMN157HVT	LSN180HSV4	LMN247HVT
Nominal Cooling Capacity (Btu/h) ¹	7,000	9,000	12,000	14,300	18,000	24,000
Nominal Heating Capacity (Btu/h) ¹	8,100	10,400	13,800	16,500	20,800	27,000
Operating Range						
Cooling (°F WB)	57-77					
Heating (°F DB)	59-81					
Fan						
Type	Cross Flow					
Motor Output (W) x Qty.	14.4 x 1			76.0 x 1		
Motor/Drive	Brushless Digitally Controlled / Direct					
Airflow Rate CFM (H/M/L)	198 / 177 / 162	247 / 230 / 212	335 / 318 / 300	371 / 318 / 247	572 / 501 / 434	720 / 600 / 466
Unit Data						
Refrigerant Type ²	R410A					
Refrigerant Control	EEV					
Power Supply V, Ø, Hz ³	208-230, 1, 60					
Rated Amps (A)	0.1	0.2			0.3	
Sound Pressure Level ±3 dB(A) (H/M/L) ⁴	33 / 30 / 26	33 / 30 / 27	39 / 36 / 31	43 / 39 / 34	37 / 33 / 28	42 / 39 / 36
Dimensions (W x H x D, in.)	35-1/4 x 11-3/8 x 8-9/32	34-7/8 x 11-1/4 x 8-1/4	34-7/8 x 11-1/4 x 8-1/4	35-1/4 x 11-3/8 x 8-9/32	40-9/16 x 12-13/16 x 9-13/16	40-9/16 x 12-25/32 x 9-27/32
Net Unit Weight (lbs.)	23	20	20	23	31	32
Shipping Weight (lbs.)	26				36	37
Power Wiring / Communications Cable (No. x AWG) ⁵	4 x 18					
Heat Exchanger (Row x Column x Fin / inch) x Number	(2 x 16 x 23) x 1				(3 x 18 x 22) x 1	
Pipe Size						
Liquid (in.)	1/4					
Vapor (in.)	3/8				1/2	
Connection Size						
Liquid (in.)	1/4				3/8	1/4
Vapor (in.)	3/8				5/8	1/2
Drain O.D. / I.D. (in.)	27/32, 5/8					

¹Nominal capacity is rated 0 ft. above sea level with corresponding refrigerant piping length in accordance with standard length of each outdoor unit and a 0 ft. level difference between outdoor and indoor units. All capacities are net with a combination ratio between 95 – 105%.

Nominal cooling capacity rating obtained with air entering the indoor unit at 80°F dry bulb (DB) and 67°F wet bulb (WB) and outdoor ambient conditions of 95°F dry bulb (DB) and 75°F wet bulb (WB).

Nominal heating capacity rating obtained with air entering the indoor unit at 70°F dry bulb (DB) and 60°F wet bulb (WB) and outdoor ambient conditions of 47°F dry bulb (DB) and 43°F wet bulb (WB).

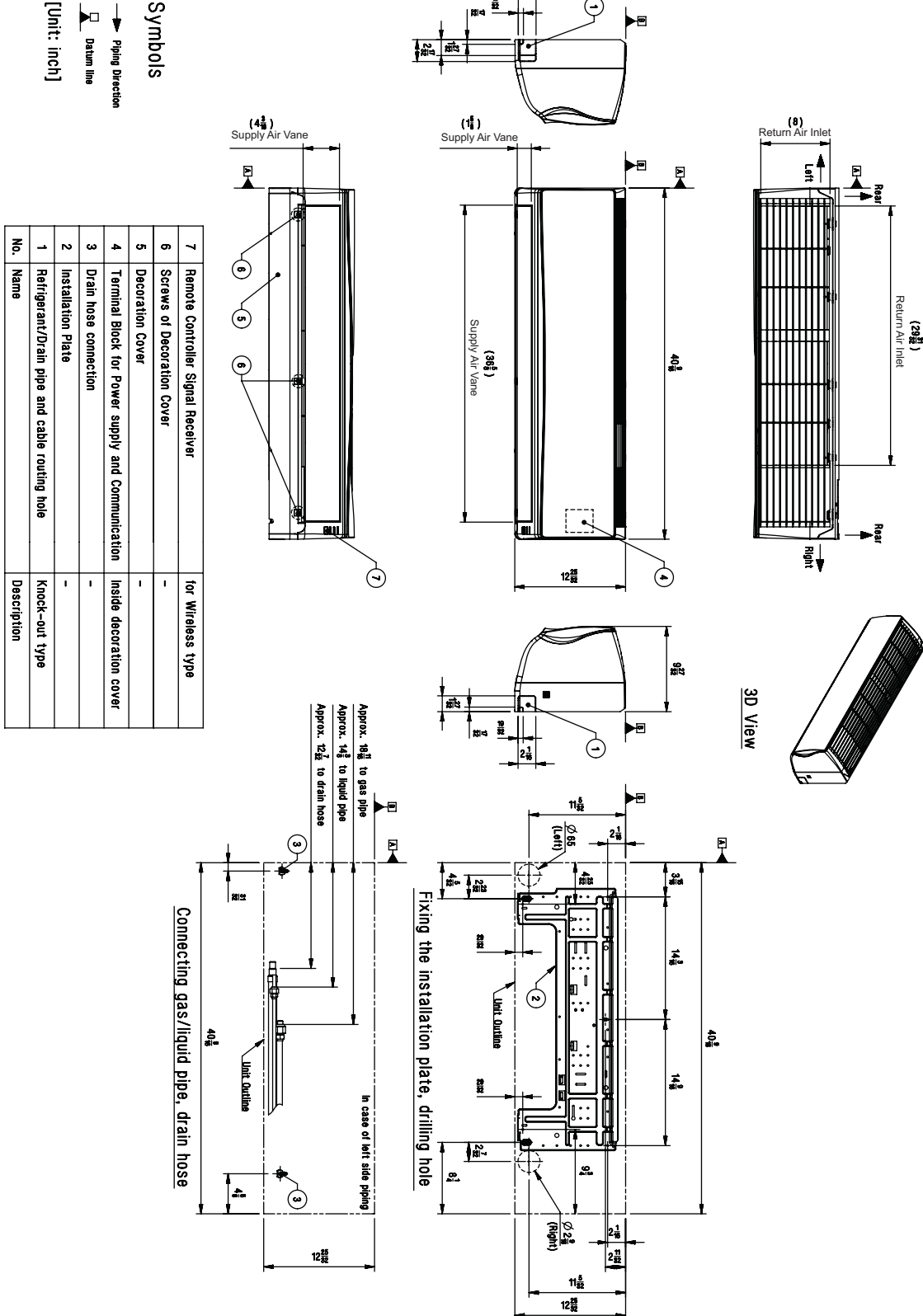
²This unit comes with a dry helium charge.

³Acceptable operating voltage: 187V-253V.

⁴Sound pressure levels are tested in an anechoic chamber under ISO Standard 3745 and are the same in both cooling and heating mode. These values can increase due to ambient conditions during operation.

⁵All power wiring / communications cable to be minimum 18 AWG, 4-conductor, stranded, shielded, and must comply with applicable local and national codes.

Figure 72: LMN247HVT Dimensions.



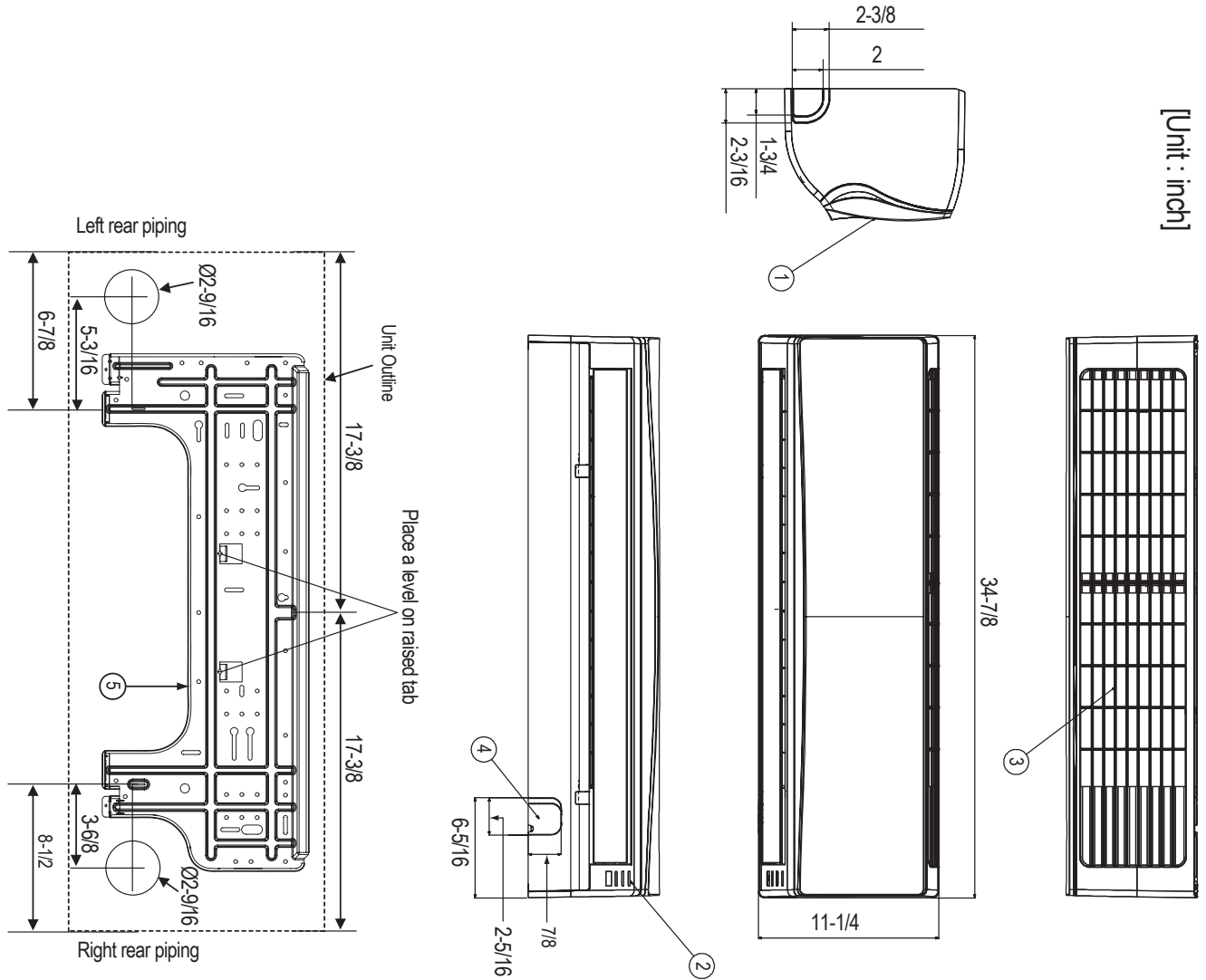
Standard Wall-Mounted

STANDARD WALL-MOUNTED INDOOR UNITS

Dimensions

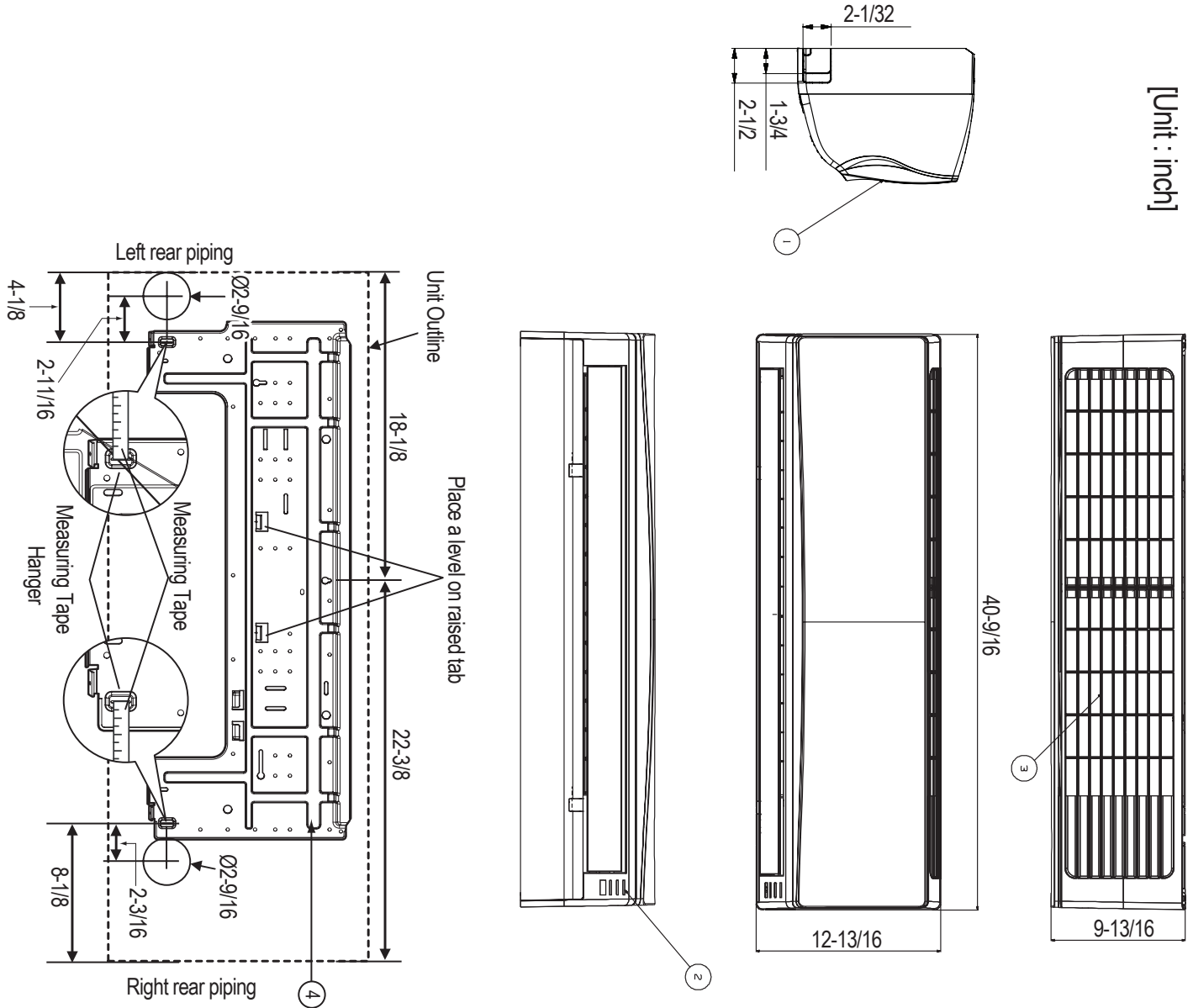
MULTI F
MULTI F MAX

Figure 73: LSN090HSV4, and LSN120HSV4 Dimensions.

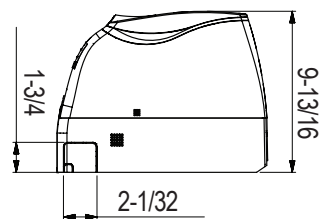


Item No.	Part Name	Remark
1	Front Panel	
2	Display & Signal Receiver	
3	Return Air Grille	
4	Knockout hole	For pipe and cable
5	Installation Plate	

Figure 74: LSN180HSV4 Dimensions.



Item No.	Part Name	Remark
1	Front Panel	
2	Display & Signal Receiver	
3	Return Air Grille	
4	Installation Plate	



STANDARD WALL-MOUNTED INDOOR UNITS

MULTI F
MULTI F MAX

Cooling Capacity Table

Table 30: Multi F Standard Wall-Mounted Indoor Units Cooling Capacity Table.

Model No. / Nominal Capacity of Indoor Unit (Btu/h)	Outdoor Air Temp. (°F DB)	Indoor Air Temp. °F DB / °F WB											
		68 / 57		73 / 61		77 / 64		80 / 67		86 / 72		90 / 75	
		TC	SHC	TC	SHC	TC	SHC	TC	SHC	TC	SHC	TC	SHC
LMN077HVT 7,000	14	6.86	4.68	7.29	4.95	7.71	4.79	8.02	4.89	8.57	4.93	8.99	5.03
	20	6.86	4.72	7.28	4.99	7.71	4.83	8.02	4.93	8.56	4.97	8.99	5.06
	25	6.85	4.76	7.28	5.02	7.70	4.86	8.01	4.97	8.55	5.01	8.98	5.10
	30	6.85	4.79	7.27	5.06	7.70	4.90	8.00	5.01	8.55	5.05	8.97	5.14
	35	6.84	4.83	7.27	5.10	7.69	4.94	8.00	5.04	8.54	5.09	8.97	5.18
	40	6.84	4.87	7.26	5.14	7.68	4.98	7.99	5.08	8.53	5.12	8.96	5.22
	45	6.83	4.90	7.25	5.18	7.68	5.01	7.99	5.12	8.53	5.16	8.95	5.26
	50	6.83	4.94	7.25	5.22	7.67	5.05	7.98	5.16	8.52	5.20	8.94	5.30
	55	6.82	4.97	7.24	5.25	7.67	5.09	7.97	5.19	8.51	5.24	8.94	5.34
	60	6.81	5.01	7.24	5.29	7.66	5.12	7.97	5.23	8.51	5.28	8.93	5.38
	65	6.81	5.05	7.23	5.33	7.66	5.16	7.96	5.27	8.50	5.31	8.92	5.42
	70	6.80	5.08	7.23	5.37	7.65	5.20	7.95	5.31	8.49	5.35	8.92	5.45
	75	6.64	5.00	7.06	5.29	7.48	5.13	7.79	5.24	8.33	5.29	8.75	5.39
	80	6.48	4.91	6.90	5.20	7.32	5.05	7.62	5.16	8.16	5.22	8.58	5.33
	85	6.31	4.82	6.73	5.12	7.15	4.97	7.46	5.09	7.99	5.15	8.41	5.26
	90	6.15	4.73	6.57	5.03	6.99	4.89	7.29	5.01	7.83	5.08	8.24	5.19
	95	5.98	4.68	6.39	4.98	6.81	4.85	7.00	4.90	7.64	5.05	8.06	5.17
	100	5.83	4.56	6.25	4.86	6.66	4.74	6.91	4.82	7.50	4.94	7.91	5.06
	105	5.69	4.43	6.10	4.73	6.52	4.62	6.82	4.75	7.35	4.83	7.77	4.96
	110	5.54	4.28	5.96	4.58	6.37	4.48	6.67	4.61	7.21	4.70	7.62	4.82
115	5.39	4.15	5.81	4.45	6.23	4.36	6.53	4.49	7.06	4.58	7.48	4.71	
118	5.31	4.12	5.72	4.42	6.14	4.34	6.44	4.47	6.97	4.57	7.39	4.70	
122	5.28	4.11	5.69	4.41	6.11	4.33	6.41	4.46	6.94	4.56	7.36	4.70	
LSN090HSV4 9,000	14	8.82	6.04	9.37	6.38	9.92	6.18	10.31	6.31	11.01	6.36	11.56	6.48
	20	8.82	6.09	9.36	6.43	9.91	6.23	10.31	6.36	11.01	6.41	11.55	6.53
	25	8.81	6.13	9.36	6.48	9.90	6.27	10.30	6.41	11.00	6.46	11.54	6.58
	30	8.80	6.18	9.35	6.53	9.90	6.32	10.29	6.46	10.99	6.51	11.54	6.63
	35	8.80	6.23	9.34	6.58	9.89	6.37	10.28	6.50	10.98	6.56	11.53	6.68
	40	8.79	6.28	9.33	6.63	9.88	6.42	10.27	6.55	10.97	6.61	11.52	6.73
	45	8.78	6.32	9.33	6.68	9.87	6.47	10.27	6.60	10.96	6.66	11.51	6.78
	50	8.78	6.37	9.32	6.73	9.87	6.51	10.26	6.65	10.96	6.71	11.50	6.83
	55	8.77	6.42	9.31	6.78	9.86	6.56	10.25	6.70	10.95	6.76	11.49	6.88
	60	8.76	6.46	9.31	6.83	9.85	6.61	10.24	6.75	10.94	6.81	11.48	6.93
	65	8.76	6.51	9.30	6.88	9.84	6.66	10.24	6.80	10.93	6.85	11.47	6.98
	70	8.75	6.56	9.29	6.92	9.84	6.70	10.23	6.85	10.92	6.90	11.47	7.03
	75	8.54	6.45	9.08	6.82	9.62	6.61	10.01	6.75	10.71	6.82	11.25	6.96
	80	8.33	6.34	8.87	6.71	9.41	6.51	9.80	6.66	10.49	6.73	11.03	6.87
	85	8.12	6.22	8.66	6.60	9.20	6.41	9.59	6.56	10.28	6.64	10.82	6.79
	90	7.91	6.10	8.45	6.48	8.99	6.31	9.37	6.46	10.06	6.55	10.60	6.70
	95	7.68	6.04	8.22	6.43	8.75	6.26	9.00	6.32	9.83	6.52	10.36	6.67
	100	7.50	5.88	8.03	6.26	8.57	6.11	8.88	6.22	9.64	6.37	10.17	6.53
	105	7.31	5.72	7.84	6.10	8.38	5.96	8.77	6.12	9.45	6.23	9.99	6.39
	110	7.12	5.52	7.66	5.90	8.19	5.78	8.58	5.94	9.26	6.06	9.80	6.22
115	6.94	5.36	7.47	5.74	8.01	5.63	8.39	5.79	9.08	5.91	9.61	6.08	
118	6.82	5.32	7.36	5.70	7.89	5.60	8.28	5.76	8.96	5.89	9.50	6.06	
122	6.79	5.30	7.32	5.69	7.86	5.59	8.24	5.76	8.93	5.89	9.46	6.06	

TC = Total Capacity (kBtu/h).

SHC: Sensible Heat Capacity (kBtu/h).

Nominal capacity as rated 0 ft. above sea level and a 0 ft. level difference between outdoor and indoor units. Corresponding refrigerant piping length is accordance with standard length of each outdoor unit.

Nominal cooling capacity rating obtained with air entering the indoor unit at 80°F dry bulb (DB) and 67°F wet bulb (WB), and outdoor ambient conditions of 95°F dry bulb (DB) and 75°F wet bulb (WB).

The shaded table columns and rows indicate reference data. When operating at this temperature, these values can be different if the system is not running consistently.

Multi F and Multi F MAX Indoor Unit Engineering Manual

Table 31: Multi F Standard Wall-Mounted Indoor Units Cooling Capacity Table (continued).

Model No. / Nominal Capacity of Indoor Unit (Btu/h)	Outdoor Air Temp. (°F DB)	Indoor Air Temp. °F DB / °F WB											
		68 / 57		73 / 61		77 / 64		80 / 67		86 / 72		90 / 75	
		TC	SHC	TC	SHC	TC	SHC	TC	SHC	TC	SHC	TC	SHC
LSN120HSV4 12,000	14	11.76	8.51	12.49	8.99	13.22	8.70	13.75	8.88	14.69	8.96	15.42	9.13
	20	11.75	8.57	12.48	9.06	13.21	8.77	13.74	8.95	14.67	9.03	15.40	9.20
	25	11.75	8.64	12.48	9.13	13.20	8.84	13.73	9.02	14.66	9.10	15.39	9.27
	30	11.74	8.71	12.47	9.20	13.19	8.90	13.72	9.09	14.65	9.17	15.38	9.34
	35	11.73	8.77	12.46	9.27	13.18	8.97	13.71	9.16	14.64	9.24	15.37	9.41
	40	11.72	8.84	12.45	9.34	13.17	9.04	13.70	9.23	14.63	9.31	15.36	9.48
	45	11.71	8.90	12.44	9.41	13.16	9.11	13.69	9.30	14.62	9.38	15.35	9.55
	50	11.70	8.97	12.43	9.47	13.15	9.17	13.68	9.37	14.61	9.45	15.33	9.62
	55	11.69	9.03	12.42	9.54	13.14	9.24	13.67	9.44	14.60	9.52	15.32	9.70
	60	11.68	9.10	12.41	9.61	13.13	9.31	13.66	9.50	14.59	9.58	15.31	9.77
	65	11.67	9.17	12.40	9.68	13.12	9.38	13.65	9.57	14.57	9.65	15.30	9.84
	70	11.66	9.23	12.39	9.75	13.11	9.44	13.64	9.64	14.56	9.72	15.29	9.91
	75	11.38	9.08	12.11	9.60	12.83	9.31	13.35	9.51	14.27	9.60	15.00	9.79
	80	11.10	8.92	11.82	9.45	12.55	9.17	13.07	9.38	13.99	9.48	14.71	9.68
	85	10.83	8.76	11.54	9.29	12.26	9.03	12.78	9.24	13.70	9.36	14.42	9.56
	90	10.55	8.60	11.26	9.13	11.98	8.88	12.50	9.10	13.42	9.22	14.13	9.43
	95	10.25	8.51	10.96	9.05	11.67	8.82	12.00	8.90	13.10	9.18	13.81	9.39
	100	10.00	8.28	10.71	8.82	11.42	8.61	11.84	8.76	12.85	8.98	13.56	9.20
	105	9.75	8.05	10.46	8.59	11.17	8.40	11.69	8.62	12.60	8.78	13.31	9.01
	110	9.50	7.77	10.21	8.31	10.92	8.14	11.44	8.37	12.35	8.53	13.07	8.76
115	9.25	7.54	9.96	8.08	10.67	7.92	11.19	8.15	12.10	8.33	12.82	8.56	
118	9.10	7.49	9.81	8.03	10.52	7.88	11.04	8.12	11.95	8.30	12.67	8.54	
122	9.05	7.47	9.76	8.01	10.48	7.87	10.99	8.11	11.90	8.29	12.62	8.53	
LMN157HVT 14,300	14	14.02	10.23	14.89	10.80	15.76	10.46	16.39	10.68	17.50	10.77	18.37	10.97
	20	14.01	10.31	14.88	10.89	15.75	10.54	16.38	10.76	17.49	10.85	18.36	11.06
	25	14.00	10.39	14.87	10.97	15.74	10.62	16.36	10.85	17.47	10.94	18.34	11.15
	30	13.99	10.47	14.85	11.06	15.72	10.70	16.35	10.93	17.46	11.02	18.33	11.23
	35	13.98	10.55	14.84	11.14	15.71	10.79	16.34	11.01	17.45	11.11	18.32	11.32
	40	13.96	10.62	14.83	11.22	15.70	10.87	16.33	11.10	17.43	11.19	18.30	11.40
	45	13.95	10.70	14.82	11.31	15.69	10.95	16.31	11.18	17.42	11.27	18.29	11.49
	50	13.94	10.78	14.81	11.39	15.68	11.03	16.30	11.26	17.41	11.36	18.27	11.57
	55	13.93	10.86	14.80	11.47	15.66	11.11	16.29	11.34	17.39	11.44	18.26	11.66
	60	13.92	10.94	14.79	11.56	15.65	11.19	16.28	11.43	17.38	11.52	18.25	11.74
	65	13.91	11.02	14.78	11.64	15.64	11.27	16.26	11.51	17.37	11.61	18.23	11.83
	70	13.90	11.10	14.76	11.72	15.63	11.35	16.25	11.59	17.35	11.69	18.22	11.91
	75	13.57	10.92	14.43	11.55	15.29	11.19	15.91	11.44	17.01	11.55	17.87	11.78
	80	13.23	10.73	14.09	11.36	14.95	11.03	15.57	11.28	16.67	11.40	17.53	11.64
	85	12.90	10.53	13.76	11.17	14.61	10.86	15.23	11.11	16.33	11.25	17.18	11.49
	90	12.57	10.33	13.42	10.98	14.28	10.68	14.90	10.94	15.99	11.09	16.84	11.34
	95	12.21	10.23	13.06	10.88	13.91	10.60	14.30	10.70	15.61	11.03	16.46	11.29
	100	11.91	9.95	12.76	10.60	13.61	10.35	14.11	10.53	15.31	10.79	16.16	11.06
	105	11.61	9.68	12.46	10.33	13.32	10.09	13.93	10.37	15.02	10.56	15.87	10.83
	110	11.32	9.35	12.17	10.00	13.02	9.78	13.63	10.06	14.72	10.26	15.57	10.53
115	11.02	9.07	11.87	9.71	12.72	9.52	13.33	9.80	14.42	10.01	15.27	10.29	
118	10.84	9.00	11.69	9.66	12.54	9.48	13.16	9.76	14.24	9.98	15.09	10.26	
122	10.78	8.98	11.63	9.64	12.48	9.46	13.10	9.74	14.18	9.97	15.03	10.25	

TC = Total Capacity (kBtu/h).

SHC: Sensible Heat Capacity (kBtu/h).

Nominal capacity as rated 0 ft. above sea level and a 0 ft. level difference between outdoor and indoor units. Corresponding refrigerant piping length is accordance with standard length of each outdoor unit.

Nominal cooling capacity rating obtained with air entering the indoor unit at 80°F dry bulb (DB) and 67°F wet bulb (WB), and outdoor ambient conditions of 95°F dry bulb (DB) and 75°F wet bulb (WB).

The shaded table columns and rows indicate reference data. When operating at this temperature, these values can be different if the system is not running consistently.

Standard Wall-Mounted

STANDARD WALL-MOUNTED INDOOR UNITS

Cooling Capacity Table

MULTI F
MULTI F MAX

Table 32: Multi F Standard Wall-Mounted Indoor Units Cooling Capacity Table (continued).

Model No. / Nominal Capacity of Indoor Unit (Btu/h)	Outdoor Air Temp. (°F DB)	Indoor Air Temp. °F DB / °F WB											
		68 / 57		73 / 61		77 / 64		80 / 67		86 / 72		90 / 75	
		TC	SHC	TC	SHC	TC	SHC	TC	SHC	TC	SHC	TC	SHC
LSN180HSV4 18,000	14	17.65	12.33	18.74	13.02	19.84	12.61	20.63	12.88	22.03	12.98	23.12	13.23
	20	17.63	12.43	18.73	13.13	19.82	12.71	20.61	12.98	22.01	13.09	23.11	13.33
	25	17.62	12.52	18.71	13.23	19.81	12.81	20.60	13.08	22.00	13.19	23.09	13.44
	30	17.60	12.62	18.70	13.33	19.79	12.91	20.58	13.18	21.98	13.29	23.07	13.54
	35	17.59	12.71	18.68	13.43	19.78	13.00	20.57	13.28	21.96	13.39	23.05	13.64
	40	17.58	12.81	18.67	13.53	19.76	13.10	20.55	13.38	21.94	13.49	23.04	13.75
	45	17.56	12.90	18.66	13.63	19.75	13.20	20.53	13.48	21.93	13.59	23.02	13.85
	50	17.55	13.00	18.64	13.73	19.73	13.30	20.52	13.58	21.91	13.69	23.00	13.95
	55	17.54	13.10	18.63	13.83	19.72	13.39	20.50	13.68	21.89	13.79	22.98	14.05
	60	17.52	13.19	18.61	13.93	19.70	13.49	20.49	13.78	21.88	13.89	22.97	14.16
	65	17.51	13.29	18.60	14.03	19.69	13.59	20.47	13.87	21.86	13.99	22.95	14.26
	70	17.50	13.38	18.58	14.13	19.67	13.69	20.46	13.97	21.84	14.09	22.93	14.36
	75	17.08	13.16	18.16	13.92	19.24	13.49	20.03	13.79	21.41	13.92	22.50	14.20
	80	16.66	12.93	17.74	13.70	18.82	13.30	19.60	13.60	20.98	13.75	22.06	14.03
	85	16.24	12.70	17.32	13.47	18.40	13.09	19.17	13.40	20.55	13.56	21.63	13.85
	90	15.82	12.46	16.90	13.23	17.97	12.88	18.75	13.19	20.12	13.37	21.20	13.67
	95	15.37	12.33	16.44	13.12	17.51	12.78	18.00	12.90	19.65	13.30	20.72	13.61
	100	14.99	12.00	16.06	12.78	17.13	12.47	17.77	12.70	19.28	13.01	20.35	13.33
	105	14.62	11.67	15.69	12.45	16.76	12.17	17.53	12.50	18.90	12.73	19.97	13.05
	110	14.24	11.27	15.32	12.05	16.39	11.79	17.16	12.13	18.53	12.36	19.60	12.70
115	13.87	10.93	14.94	11.71	16.01	11.48	16.79	11.82	18.15	12.07	19.22	12.41	
118	13.65	10.85	14.72	11.64	15.79	11.42	16.56	11.77	17.93	12.03	19.00	12.37	
122	13.57	10.83	14.64	11.62	15.71	11.40	16.49	11.75	17.85	12.01	18.92	12.36	
LMN247HVT 24,000	14	23.53	16.82	24.99	17.77	26.45	17.21	27.50	17.57	29.37	17.72	30.83	18.05
	20	23.51	16.95	24.97	17.91	26.43	17.34	27.48	17.70	29.35	17.85	30.81	18.19
	25	23.49	17.08	24.95	18.05	26.41	17.47	27.46	17.84	29.33	17.99	30.79	18.33
	30	23.47	17.21	24.93	18.19	26.39	17.61	27.44	17.98	29.30	18.13	30.76	18.47
	35	23.46	17.35	24.91	18.32	26.37	17.74	27.42	18.12	29.28	18.27	30.74	18.61
	40	23.44	17.48	24.89	18.46	26.35	17.88	27.40	18.25	29.26	18.41	30.72	18.75
	45	23.42	17.61	24.87	18.60	26.33	18.01	27.38	18.39	29.24	18.54	30.69	18.89
	50	23.40	17.74	24.85	18.74	26.31	18.14	27.36	18.52	29.21	18.68	30.67	19.03
	55	23.38	17.87	24.84	18.87	26.29	18.27	27.34	18.66	29.19	18.82	30.64	19.17
	60	23.37	18.00	24.82	19.01	26.27	18.41	27.32	18.79	29.17	18.95	30.62	19.31
	65	23.35	18.13	24.80	19.15	26.25	18.54	27.29	18.93	29.15	19.09	30.60	19.45
	70	23.33	18.26	24.78	19.28	26.23	18.67	27.27	19.07	29.13	19.23	30.57	19.59
	75	22.77	17.95	24.21	18.99	25.66	18.41	26.70	18.81	28.55	18.99	29.99	19.37
	80	22.21	17.65	23.65	18.69	25.09	18.14	26.13	18.55	27.97	18.75	29.42	19.14
	85	21.65	17.33	23.09	18.38	24.53	17.86	25.57	18.28	27.40	18.50	28.84	18.90
	90	21.09	17.00	22.53	18.06	23.96	17.57	25.00	18.00	26.83	18.24	28.27	18.65
	95	20.49	16.82	21.92	17.89	23.35	17.44	24.00	17.60	26.20	18.14	27.63	18.57
	100	19.99	16.37	21.42	17.44	22.85	17.02	23.69	17.33	25.70	17.75	27.13	18.19
	105	19.49	15.92	20.92	16.99	22.35	16.60	23.38	17.06	25.20	17.36	26.63	17.81
	110	18.99	15.38	20.42	16.44	21.85	16.09	22.88	16.55	24.70	16.87	26.13	17.32
115	18.49	14.91	19.92	15.98	21.35	15.66	22.38	16.12	24.20	16.47	25.63	16.93	
118	18.19	14.81	19.62	15.88	21.05	15.59	22.08	16.05	23.90	16.41	25.33	16.88	
122	18.10	14.77	19.52	15.85	20.95	15.56	21.98	16.03	23.81	16.39	25.23	16.86	

TC = Total Capacity (kBtu/h).

SHC: Sensible Heat Capacity (kBtu/h).

Nominal capacity as rated 0 ft. above sea level and a 0 ft. level difference between outdoor and indoor units. Corresponding refrigerant piping length is accordance with standard length of each outdoor unit.

Nominal cooling capacity rating obtained with air entering the indoor unit at 80°F dry bulb (DB) and 67°F wet bulb (WB), and outdoor ambient conditions of 95°F dry bulb (DB) and 75°F wet bulb (WB).

The shaded table columns and rows indicate reference data. When operating at this temperature, these values can be different if the system is not running consistently.

Multi F and Multi F MAX Indoor Unit Engineering Manual

Table 33: Multi F Standard Wall-Mounted Indoor Units Heating Capacity Table.

Model No. / Nominal Capacity of Indoor Unit (Btu/h)	Outdoor Air Temp.		Indoor Air Temp. °F DB					
	°F DB	°F WB	61	64	68	70	72	75
			TC	TC	TC	TC	TC	TC
LMN077HVT 7,000	0	-0.4	4.17	4.11	4.07	4.05	3.99	3.82
	5	4.5	4.70	4.64	4.60	4.58	4.52	4.34
	10	9	5.22	5.17	5.13	5.11	5.05	4.87
	17	15	5.93	5.87	5.83	5.81	5.75	5.56
	20	19	6.19	6.13	6.09	6.08	6.02	5.81
	25	23	6.63	6.57	6.53	6.52	6.46	6.22
	30	28	7.01	6.96	6.92	6.90	6.84	6.63
	35	32	7.40	7.34	7.30	7.28	7.22	7.04
	40	36	7.74	7.68	7.64	7.62	7.56	7.39
	45	41	8.08	8.02	7.98	7.96	7.90	7.73
	47	43	8.22	8.16	8.12	8.10	8.04	7.87
	50	46	8.35	8.29	8.25	8.23	8.17	7.98
	55	51	8.57	8.51	8.47	8.45	8.39	8.16
	60	56	8.57	8.51	8.47	8.45	8.39	8.20
	63	59	8.57	8.51	8.47	8.45	8.39	8.22
	68	64	8.57	8.51	8.47	8.45	8.39	8.25
LSN090HSV4 9,000	0	-0.4	5.35	5.28	5.23	5.20	5.12	4.90
	5	4.5	6.03	5.95	5.90	5.88	5.80	5.58
	10	9	6.71	6.63	6.58	6.56	6.48	6.26
	17	15	7.61	7.54	7.49	7.46	7.39	7.14
	20	19	7.95	7.88	7.83	7.80	7.72	7.46
	25	23	8.52	8.44	8.39	8.37	8.29	7.99
	30	28	9.01	8.93	8.88	8.86	8.78	8.52
	35	32	9.50	9.42	9.37	9.34	9.27	9.04
	40	36	9.94	9.86	9.81	9.78	9.71	9.48
	45	41	10.37	10.30	10.25	10.22	10.15	9.92
	47	43	10.55	10.48	10.43	10.40	10.32	10.10
	50	46	10.72	10.64	10.59	10.57	10.49	10.24
	55	51	11.00	10.93	10.88	10.85	10.78	10.48
	60	56	11.00	10.93	10.88	10.85	10.78	10.52
	63	59	11.00	10.93	10.88	10.85	10.78	10.55
	68	64	11.00	10.93	10.88	10.85	10.78	10.60
LSN120HSV4 12,000	0	-0.4	7.10	7.00	6.93	6.90	6.80	6.50
	5	4.5	8.00	7.90	7.83	7.80	7.70	7.40
	10	9	8.90	8.80	8.73	8.70	8.60	8.30
	17	15	10.10	10.00	9.93	9.90	9.80	9.48
	20	19	10.55	10.45	10.38	10.35	10.25	9.90
	25	23	11.30	11.20	11.13	11.10	11.00	10.60
	30	28	11.95	11.85	11.78	11.75	11.65	11.30
	35	32	12.60	12.50	12.43	12.40	12.30	12.00
	40	36	13.18	13.08	13.02	12.98	12.88	12.58
	45	41	13.77	13.67	13.60	13.57	13.47	13.17
	47	43	14.00	13.90	13.83	13.80	13.70	13.40
	50	46	14.23	14.13	14.06	14.03	13.93	13.59
	55	51	14.60	14.50	14.43	14.40	14.30	13.90
	60	56	14.60	14.50	14.43	14.40	14.30	13.96
	63	59	14.60	14.50	14.43	14.40	14.30	14.00
	68	64	14.60	14.50	14.43	14.40	14.30	14.06

TC = Total Capacity (kBtu/h).

Nominal capacity as rated 0 ft. above sea level and a 0 ft. level difference between outdoor and indoor units. Corresponding refrigerant piping length is accordance with standard length of each outdoor unit.

Nominal heating capacity rating obtained with air entering the indoor unit at 70°F dry bulb (DB) and 60°F wet bulb (WB), and outdoor ambient conditions of 47°F dry bulb (DB) and 43°F wet bulb (WB).

Standard Wall-Mounted

STANDARD WALL-MOUNTED INDOOR UNITS

Heating Capacity Table

MULTI F
MULTI F MAX

Table 34: Multi F Standard Wall-Mounted Indoor Units Heating Capacity Table.

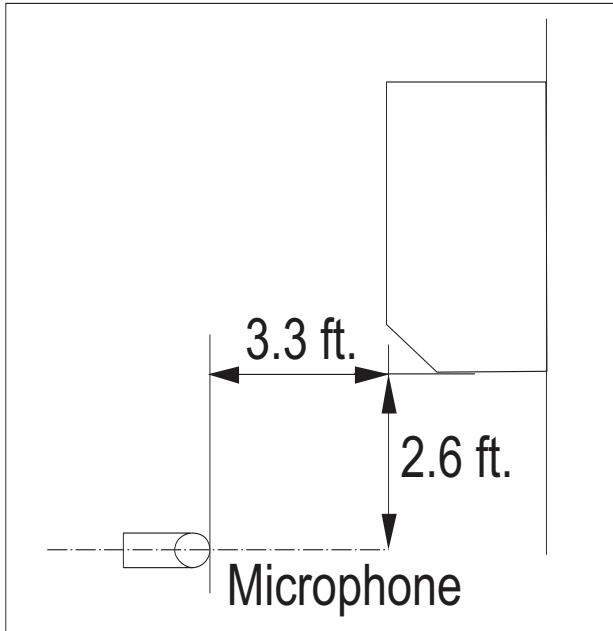
Model No. / Nominal Capacity of Indoor Unit (Btu/h)	Outdoor Air Temp.		Indoor Air Temp. °F DB					
	°F DB	°F WB	61	64	68	70	72	75
			TC	TC	TC	TC	TC	TC
LMN157HVT 14,300	0	-0.4	8.49	8.37	8.29	8.25	8.13	7.77
	5	4.5	9.57	9.45	9.37	9.33	9.21	8.85
	10	9	10.64	10.52	10.44	10.40	10.28	9.92
	17	15	12.08	11.96	11.88	11.84	11.72	11.33
	20	19	12.61	12.49	12.41	12.38	12.26	11.84
	25	23	13.51	13.39	13.31	13.27	13.15	12.67
	30	28	14.29	14.17	14.09	14.05	13.93	13.51
	35	32	15.07	14.95	14.87	14.83	14.71	14.35
	40	36	15.76	15.64	15.56	15.52	15.40	15.05
	45	41	16.46	16.34	16.26	16.22	16.10	15.74
	47	43	16.74	16.62	16.54	16.50	16.38	16.02
	50	46	17.01	16.89	16.81	16.77	16.65	16.25
	55	51	17.46	17.34	17.26	17.22	17.10	16.62
	60	56	17.46	17.34	17.26	17.22	17.10	16.69
	63	59	17.46	17.34	17.26	17.22	17.10	16.74
68	64	17.46	17.34	17.26	17.22	17.10	16.81	
LSN180HSV4 18,000	0	-0.4	10.70	10.55	10.45	10.40	10.25	9.80
	5	4.5	12.06	11.91	11.81	11.76	11.61	11.15
	10	9	13.41	13.26	13.16	13.11	12.96	12.51
	17	15	15.22	15.07	14.97	14.92	14.77	14.29
	20	19	15.90	15.75	15.65	15.60	15.45	14.92
	25	23	17.03	16.88	16.78	16.73	16.58	15.98
	30	28	18.01	17.86	17.76	17.71	17.56	17.03
	35	32	18.99	18.84	18.74	18.69	18.54	18.09
	40	36	19.87	19.72	19.62	19.57	19.42	18.97
	45	41	20.75	20.60	20.50	20.45	20.30	19.85
	47	43	21.10	20.95	20.85	20.80	20.65	20.20
	50	46	21.44	21.29	21.19	21.14	20.99	20.48
	55	51	22.01	21.86	21.75	21.70	21.55	20.95
	60	56	22.01	21.86	21.75	21.70	21.55	21.04
	63	59	22.01	21.86	21.75	21.70	21.55	21.10
68	64	22.01	21.86	21.75	21.70	21.55	21.20	
LMN247HVT 24,000	0	-0.4	13.89	13.70	13.57	13.50	13.30	12.72
	5	4.5	15.65	15.46	15.33	15.26	15.07	14.48
	10	9	17.41	17.22	17.09	17.02	16.83	16.24
	17	15	19.76	19.57	19.43	19.37	19.17	18.55
	20	19	20.64	20.45	20.32	20.25	20.05	19.37
	25	23	22.11	21.91	21.78	21.72	21.52	20.74
	30	28	23.38	23.18	23.05	22.99	22.79	22.11
	35	32	24.65	24.46	24.33	24.26	24.07	23.48
	40	36	25.79	25.60	25.47	25.40	25.21	24.62
	45	41	26.93	26.74	26.61	26.54	26.35	25.76
	47	43	27.39	27.20	27.07	27.00	26.80	26.22
	50	46	27.83	27.64	27.51	27.44	27.24	26.58
	55	51	28.57	28.37	28.24	28.17	27.98	27.20
	60	56	28.57	28.37	28.24	28.17	27.98	27.32
	63	59	28.57	28.37	28.24	28.17	27.98	27.39
68	64	28.57	28.37	28.24	28.17	27.98	27.51	

TC = Total Capacity (kBtu/h).

Nominal capacity as rated 0 ft. above sea level and a 0 ft. level difference between outdoor and indoor units. Corresponding refrigerant piping length is accordance with standard length of each outdoor unit.

Nominal heating capacity rating obtained with air entering the indoor unit at 70°F dry bulb (DB) and 60°F wet bulb (WB), and outdoor ambient conditions of 47°F dry bulb (DB) and 43°F wet bulb (WB).

Figure 75: Sound Pressure Level Measurement Location.

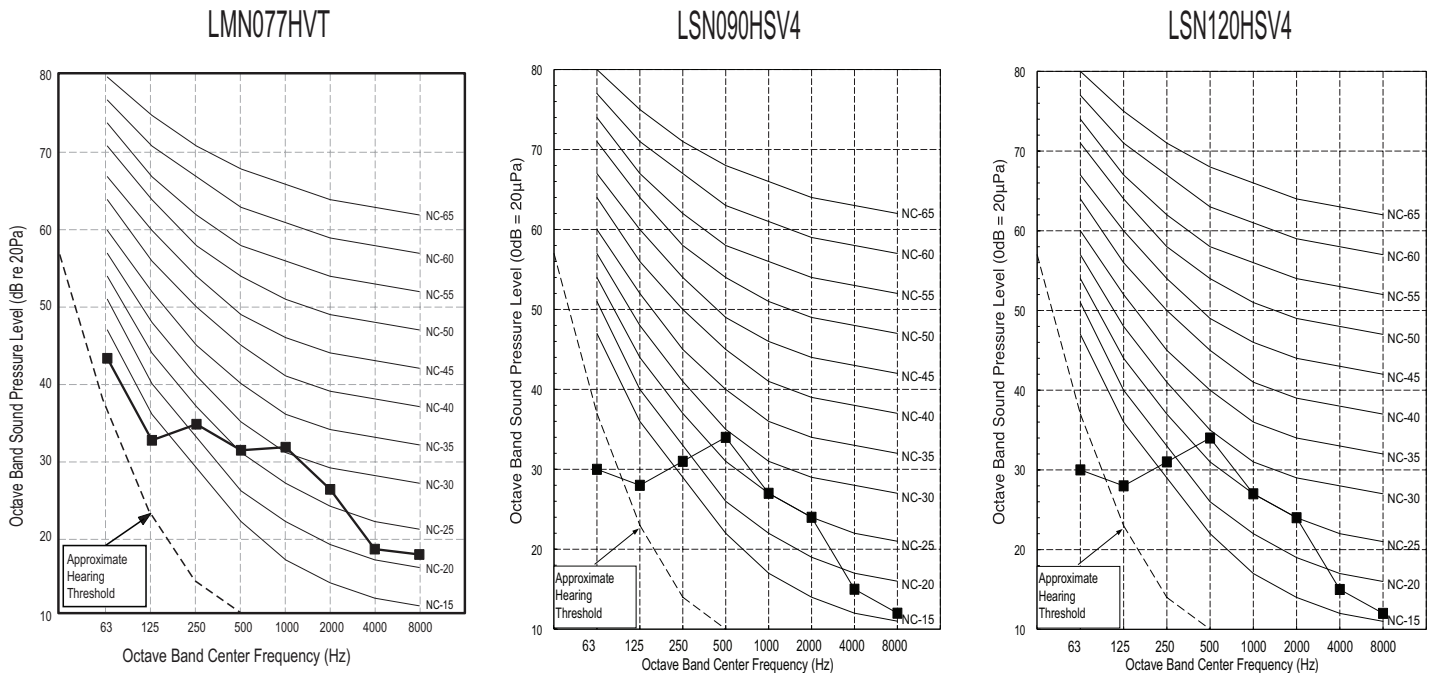


- Measurement taken 2.6' below the bottom of the unit and at a distance of 3.3' from face of unit.
- Measurements taken with no attenuation and units operating at full load normal operating condition.
- Sound level will vary depending on a range of factors such as construction (acoustic absorption coefficient) of particular area in which the equipment is installed.
- Sound power levels are measured in dB(A)±3.
- Tested in anechoic chamber per ISO Standard 3745.

Table 35: Sound Pressure Levels (dB[A]).

Model No.	Sound Pressure Levels (dB[A]) (Cooling and Heating)		
	High Fan Speed	Medium Fan Speed	Low Fan Speed
LMN077HVT	33	30	26
LSN090HSV4	33	30	27
LSN120HSV4	39	36	31
LMN157HVT	43	39	34
LSN180HSV4	37	33	28
LMN247HVT	42	39	36

Figure 76: LMN077HVT, LSN090HSV4, and LSN120HSV4 Sound Pressure Level Diagrams.

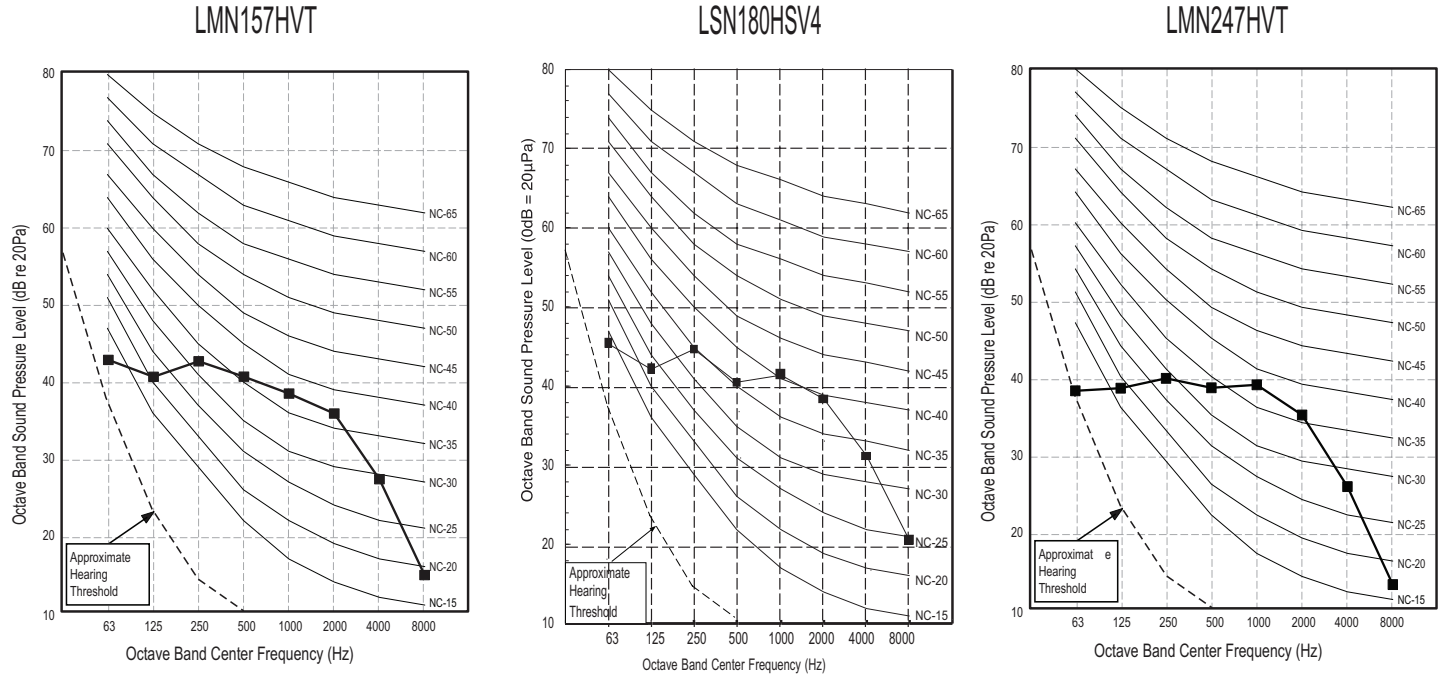


STANDARD WALL-MOUNTED INDOOR UNITS

Acoustic Data

MULTI F
MULTI F MAX

Figure 77:LMN157HVT, LSN180HSV4, and LMN247HVT Sound Pressure Level Diagrams.



Multi F and Multi F MAX Indoor Unit Engineering Manual

Figure 78:LMN077HVT Air Velocity and Temperature Distribution Charts.

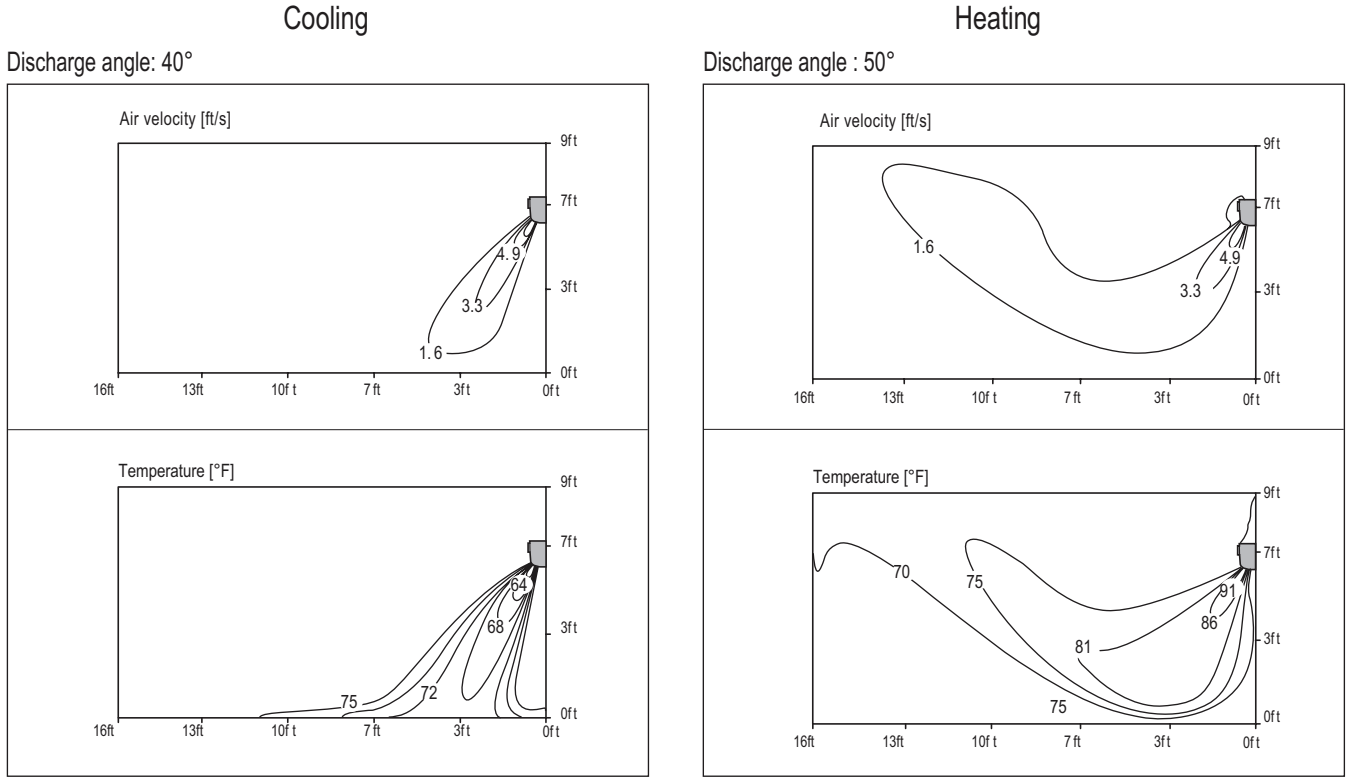
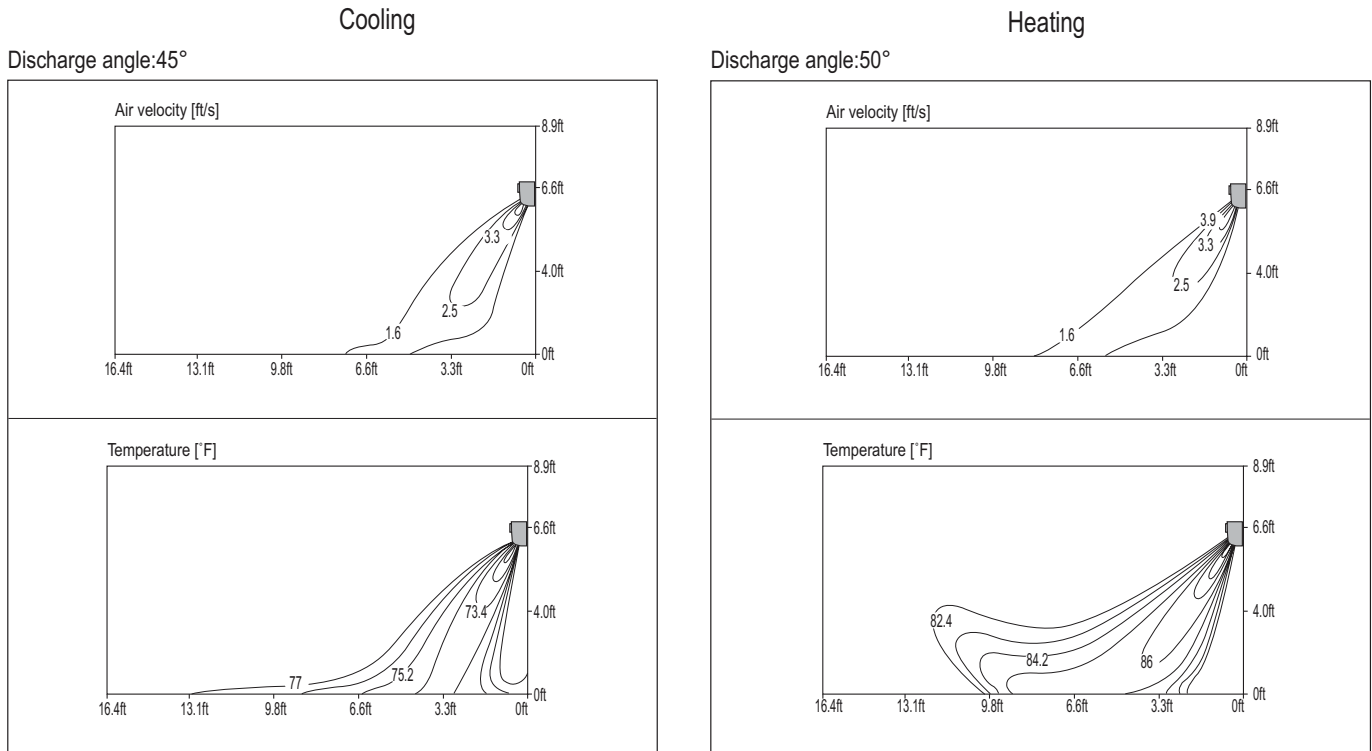


Figure 79:LSN090HSV4 Air Velocity and Temperature Distribution Charts.



STANDARD WALL-MOUNTED INDOOR UNITS

Air Velocity and Temperature Distribution

MULTI F
MULTI F MAX

Figure 80:LSN120HSV4 Air Velocity and Temperature Distribution Charts.

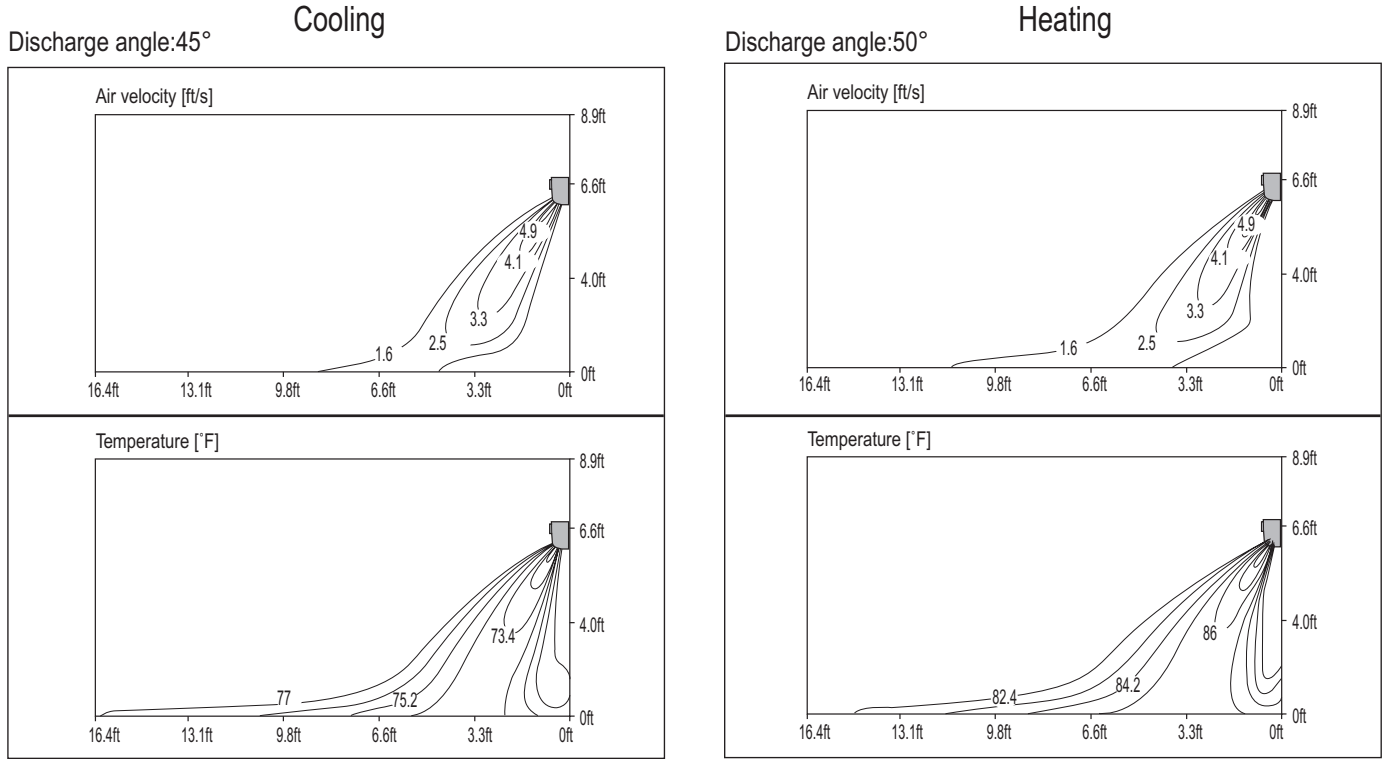


Figure 81:LMN157HVT Air Velocity and Temperature Distribution Charts.

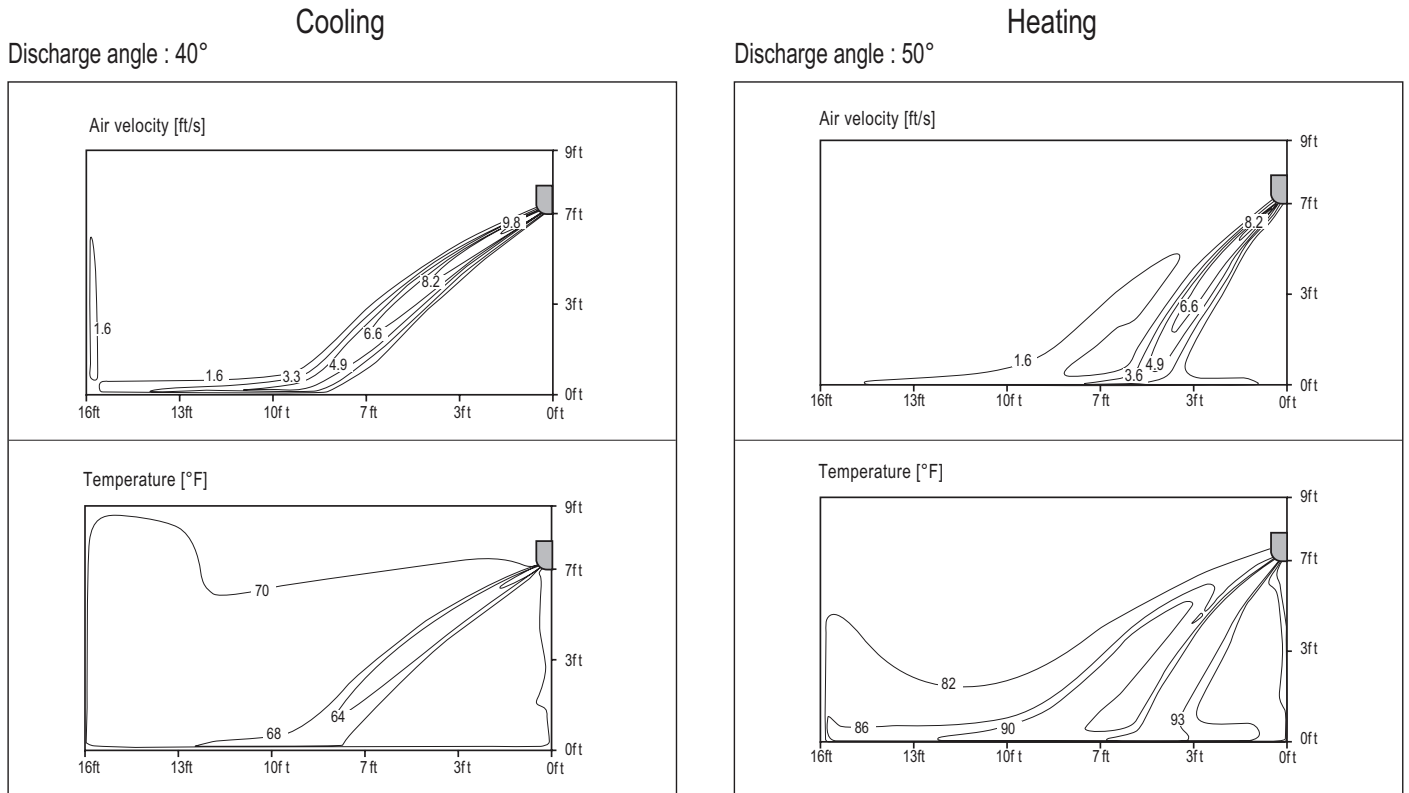


Figure 82: LSN180HSV4 Air Velocity and Temperature Distribution Charts.

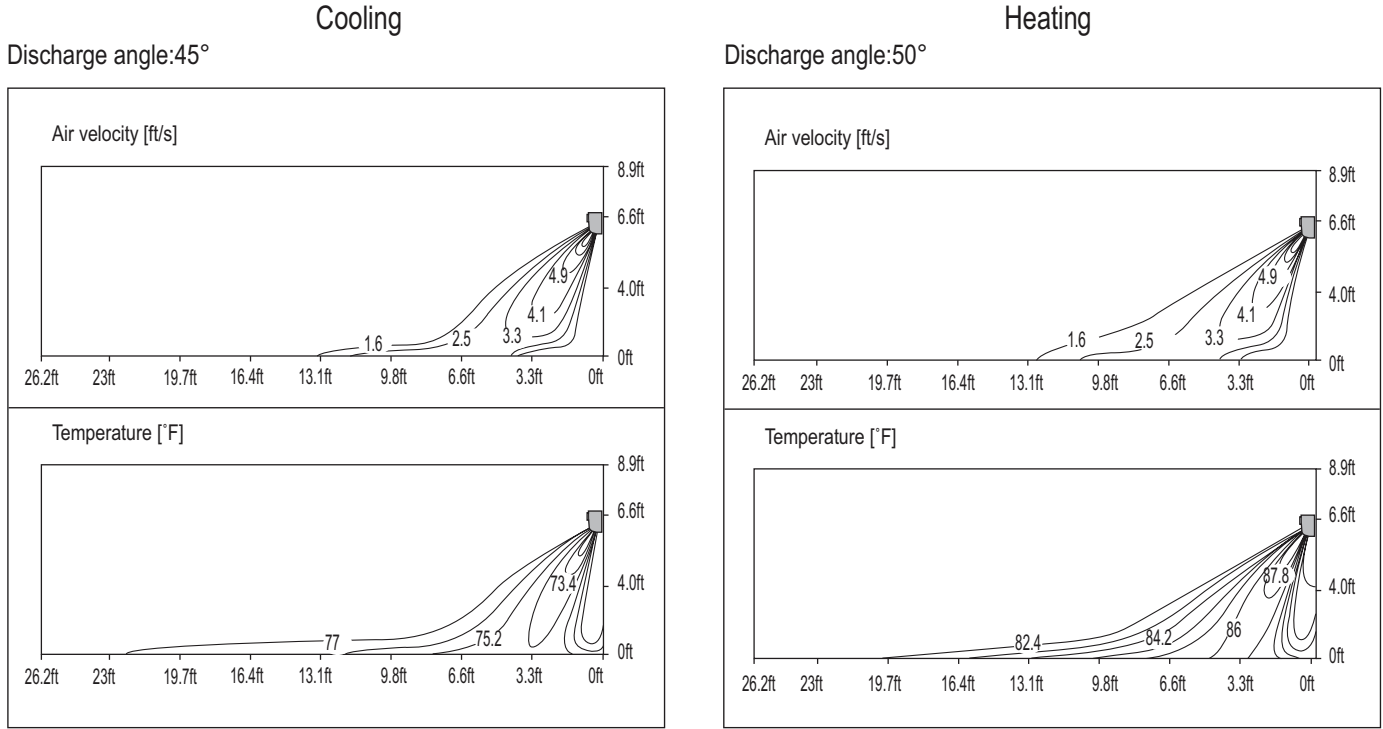
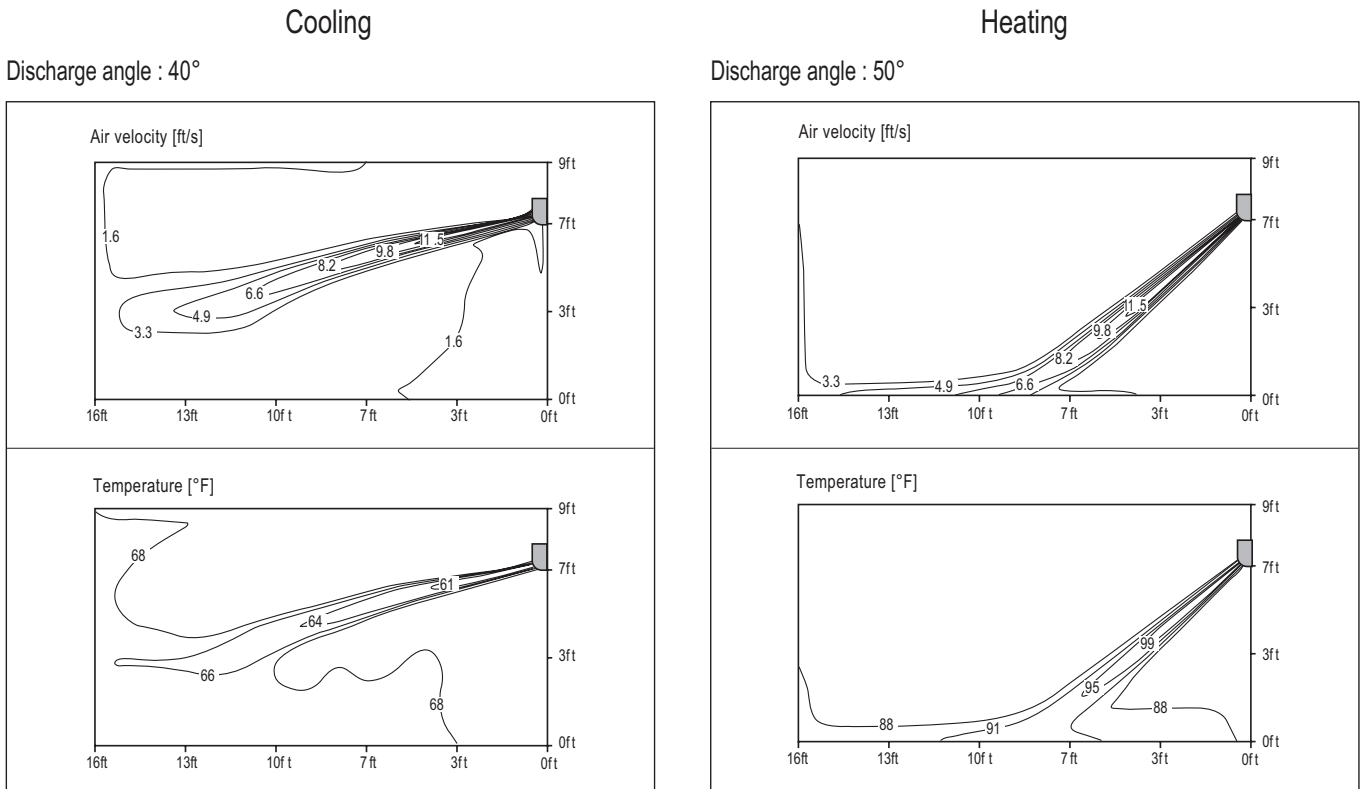


Figure 83: LMN247HVT Air Velocity and Temperature Distribution Charts.



Standard Wall-Mounted

STANDARD WALL-MOUNTED INDOOR UNITS

Refrigerant Flow Diagram

MULTI F
MULTI F MAX

Figure 84: Multi F Standard Wall-Mounted Indoor Unit Refrigerant Flow Diagram.

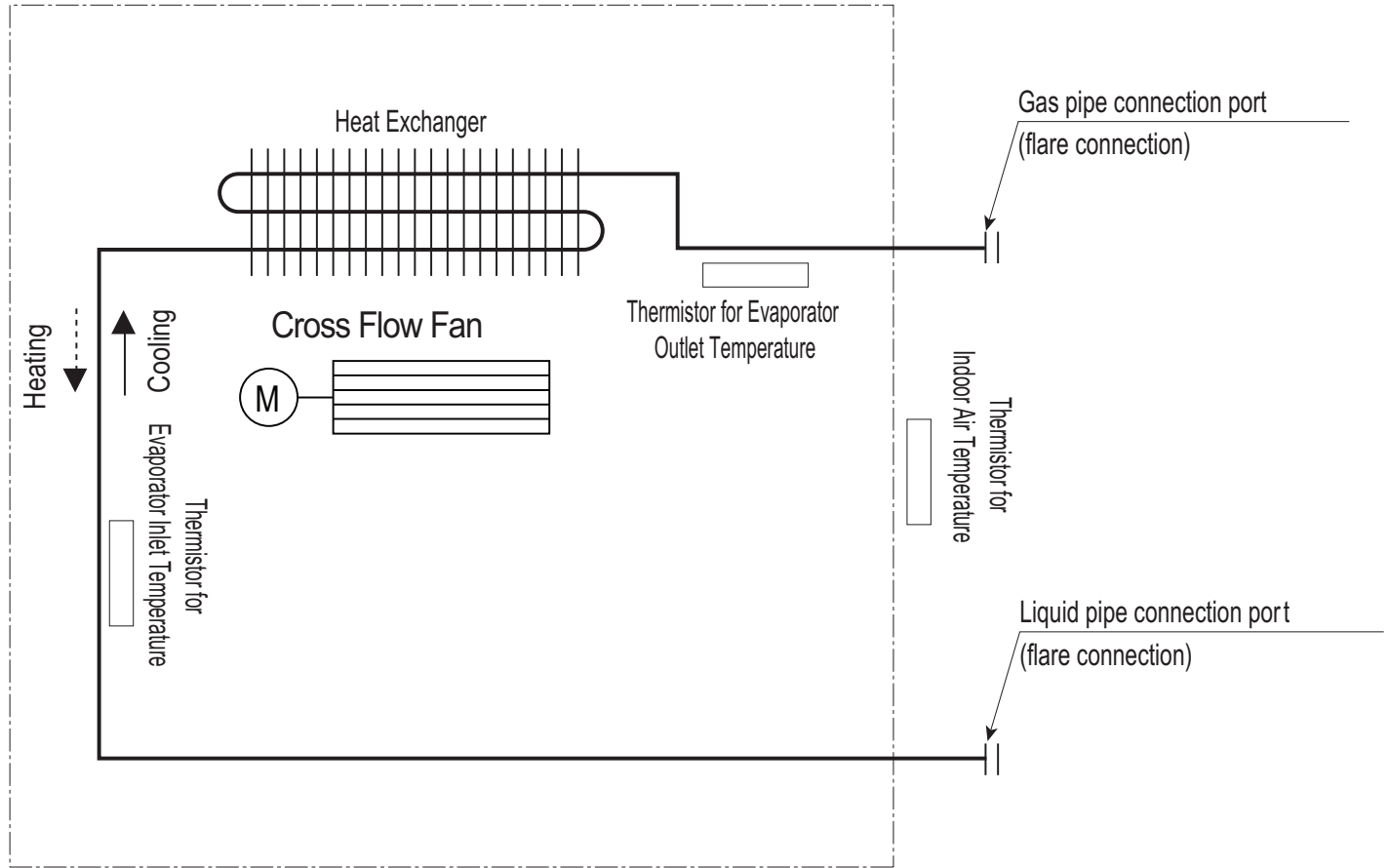


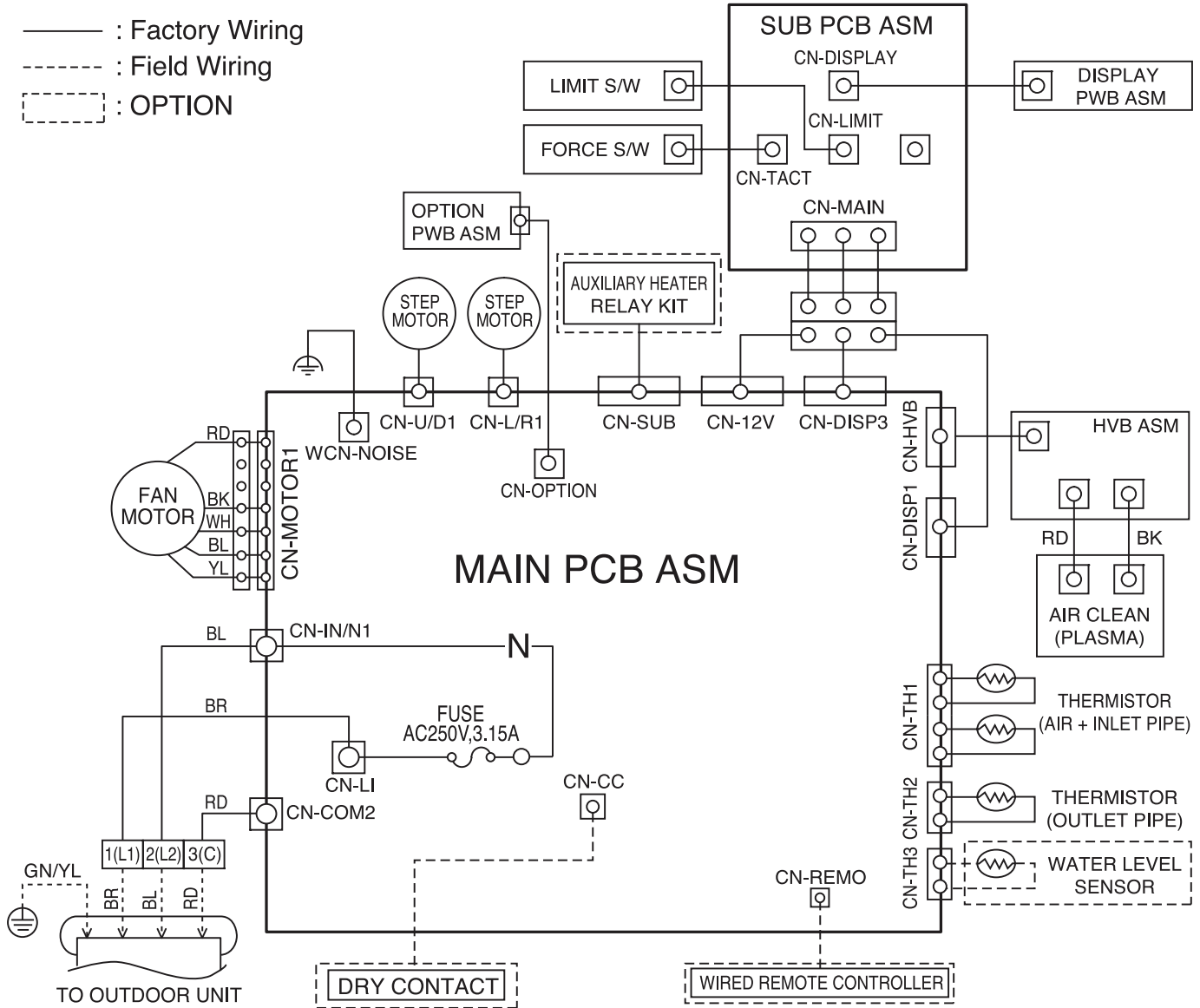
Table 36: Multi F Standard Wall-Mounted Indoor Unit Refrigerant Pipe Connection Port Diameters.

Model No.	Vapor (inch)	Liquid (inch)
LMN077HVT	Ø3/8	Ø1/4
LSN090HSV4		
LSN120HSV4		
LMN157HVT	Ø5/8	Ø3/8
LSN180HSV4		
LMN247HVT	Ø1/2	Ø1/4

Table 37: Multi F Standard Wall-Mounted Indoor Unit Thermistor Details.

Description (Based on Cooling Mode)	PCB Connector
Indoor Air Temperature Thermistor	CN-TH1
Evaporator Inlet Temperature Thermistor	
Evaporator Outlet Temperature Thermistor	CN-TH2
Water Level Sensor (Optional)	CN-TH3

Figure 85: Multi F Standard Wall-Mounted LMN077HVT and LMN157HVT Indoor Units Wiring Diagram.



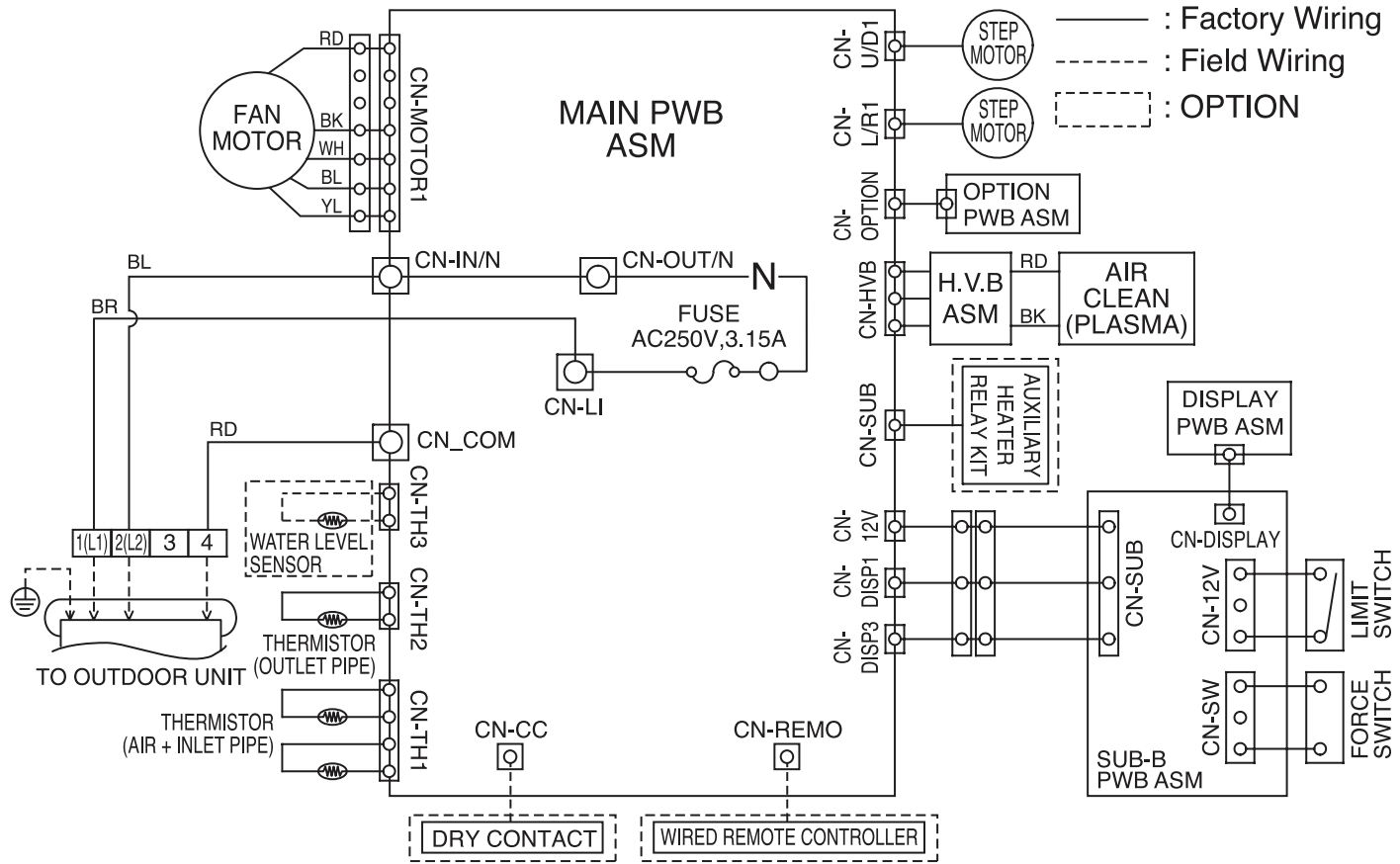
Standard Wall-Mounted

STANDARD WALL-MOUNTED INDOOR UNITS

Wiring Diagram

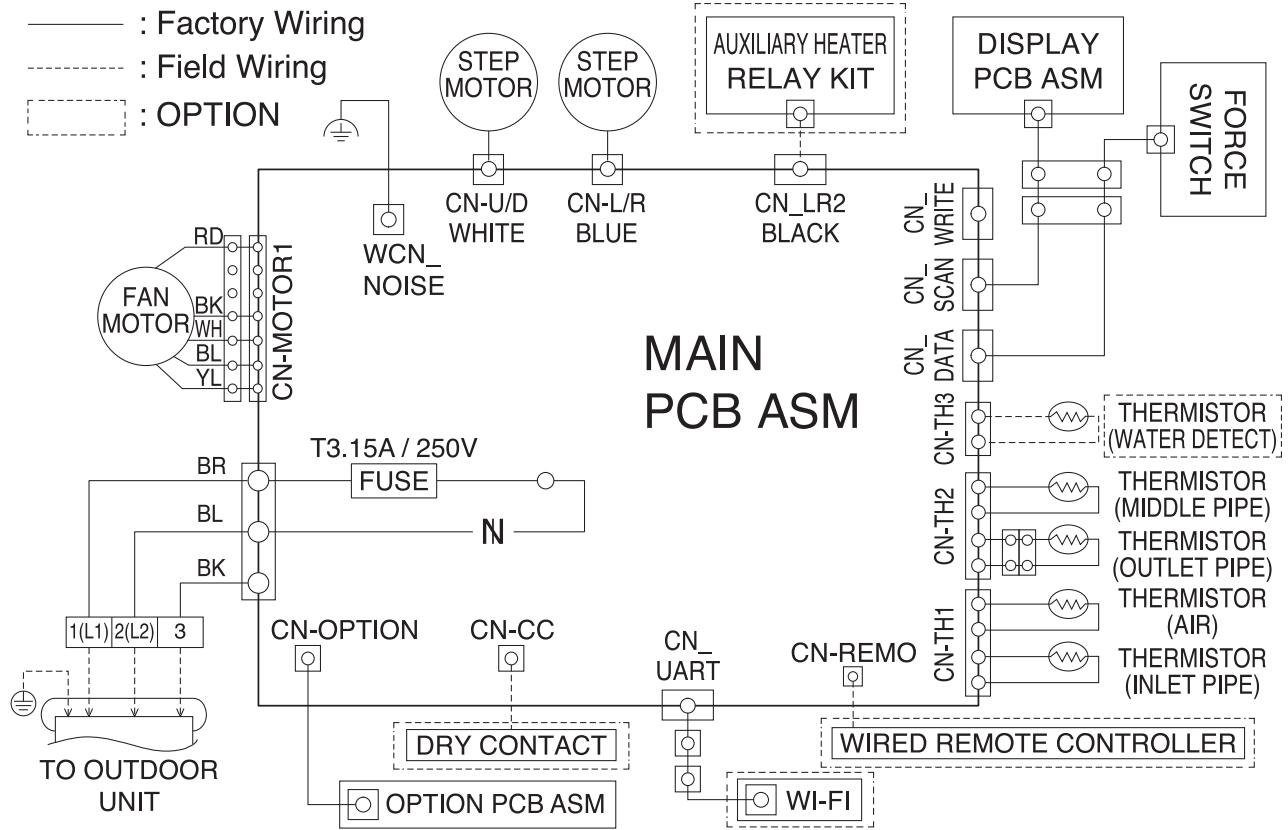
MULTI F
MULTI F MAX

Figure 86: Multi F Standard Wall-Mounted LMN247HVT Indoor Unit Wiring Diagram.



Multi F and Multi F MAX Indoor Unit Engineering Manual

Figure 87: Multi F Standard Wall-Mounted LSN090HSV4 and LSN120HSV4 Indoor Units Wiring Diagram.



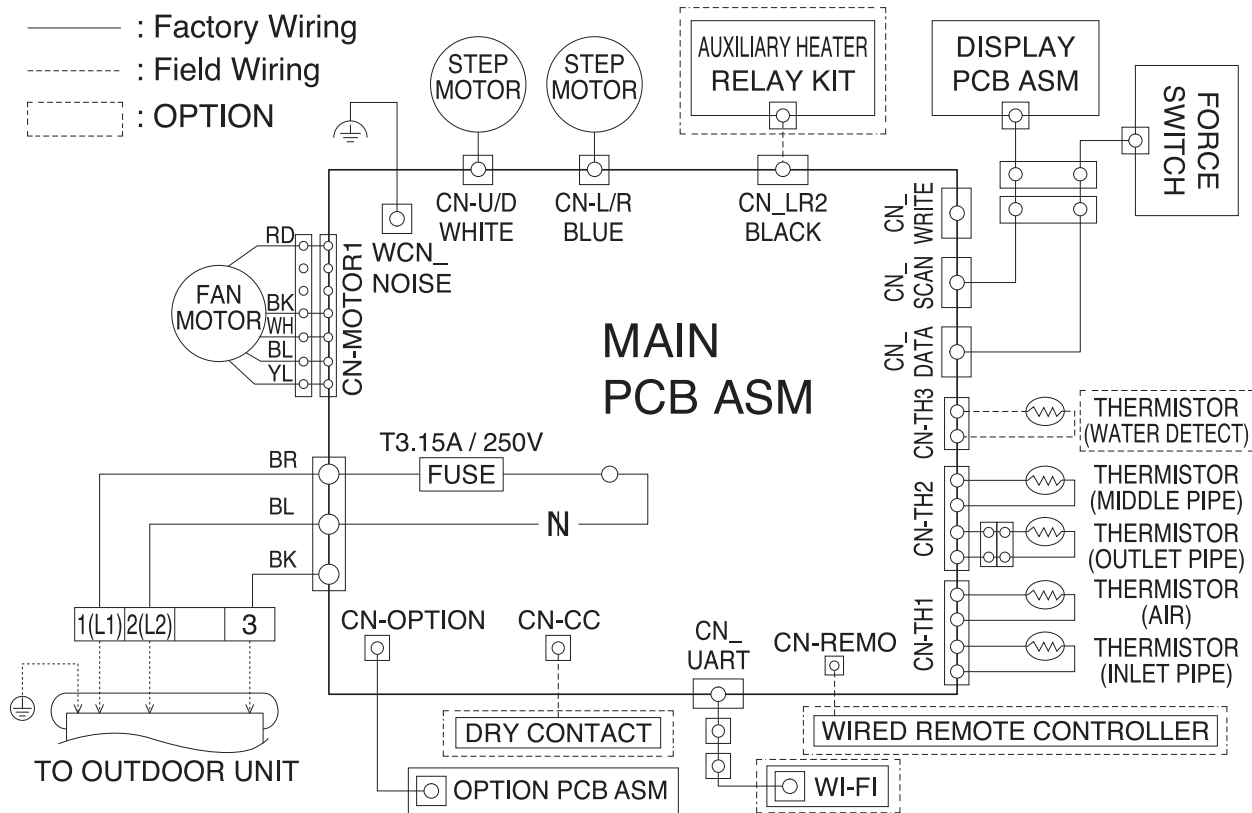
Standard Wall-Mounted

STANDARD WALL-MOUNTED INDOOR UNITS

Wiring Diagram

MULTI F
MULTI F MAX

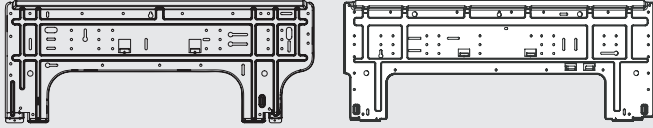
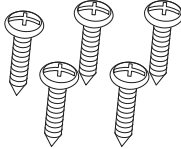
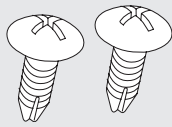

Figure 88: Multi F Standard Wall-Mounted LSN180HSV4 Indoor Unit Wiring Diagram.



Multi F and Multi F MAX Indoor Unit Engineering Manual

Factory Supplied Parts

Table 38: Parts Table.

Part	Quantity	Image
Installation Plate	One (1)	 <p>7,000 ~ 15,000 Btu/h Indoor Units 18,000 and 24,000 Btu/h Indoor Units</p>
Type "A" Screws	Five (5)	
Type "B" Screws (M4 x 12L)	Two (2)	
Wireless Controller with Holder HVT: AKB73635606 HSV: AKB73835312	One (1)	

Factory Supplied Materials

- Owner's Manual
- Installation Manual

Required Tools

- Level
- Screwdriver
- Electric drill
- Hole core drill
- Flaring tool set
- Spanner (Half union)
- Thermometer

⚠ WARNING

- Read all instructions before installing the product.
- Installation work must be performed by authorized personnel and in accordance with the national wiring standards and all local codes.

STANDARD WALL-MOUNTED INDOOR UNITS

Installation and Best Layout Practices

MULTI F
MULTI F MAX

Selecting the Best Location

Do's

- Place the unit where air circulation will not be blocked.
- Place the unit where drainage can be obtained easily.
- Place the unit where noise prevention is taken into consideration.
- Ensure there is sufficient space from the ceiling and floor.
- Ensure there is sufficient maintenance space.
- Locate the indoor unit in a location where it can be easily connected to the outdoor unit / branch distribution unit.

⚠ WARNING

Don'ts

- The unit should not be installed near a heat or steam source, or where considerable amounts of oil, iron powder, or flour are used.
- The unit should not be installed where sulfuric acid and flammable or corrosive gases are generated, vented into, or stored.
- Avoid installing the unit near high-frequency generators.
- Do not install the unit near a doorway.

The unit may be damaged, may malfunction, and / or will not operate as designed if installed in any of the conditions listed.

Installing in an Area Exposed to Unconditioned Air

In some installation applications, areas (floors, walls) in some rooms may be exposed to unconditioned air (room may be above or next to an unheated garage or storeroom). To countermeasure:

- Verify that carpet is or will be installed (carpet may increase the temperature by three degrees).
- Add insulation between the floor joists.
- Install radiant heat or another type of heating system to the floor.

Mounting the Installation Plate

The mounting wall should be strong and solid enough to protect the unit from vibration.

- Mount the installation plate on the wall using the Type "A" screws. If mounting the unit on concrete, consider using anchor bolts.
- Always mount the installation plate horizontally. Measure the wall and mark the centerline using thread and a level.

Figure 89: Minimum Clearance Requirements.

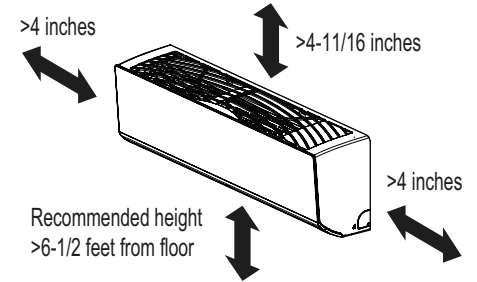


Figure 90: Installation Plate—Side View.

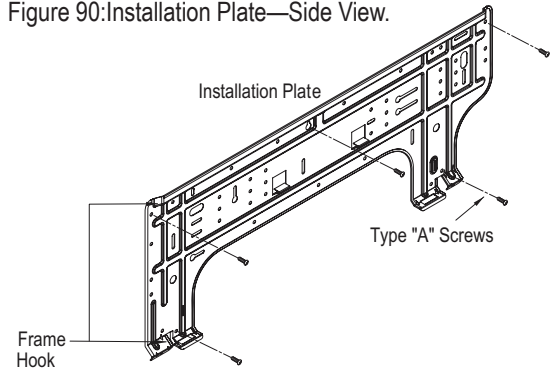


Figure 91: Installation Plate for LMN077HVT, LSN090HSV4, LSN120HSV4, and LMN157HVT Units.

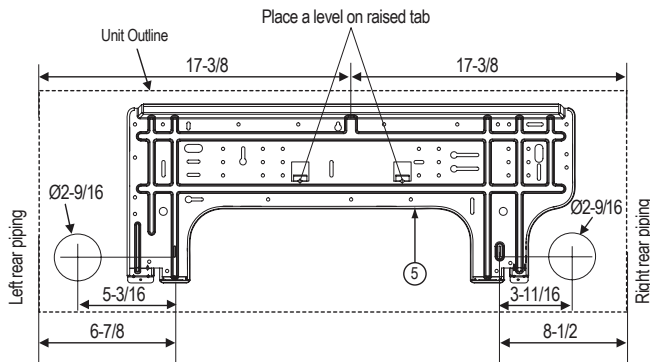
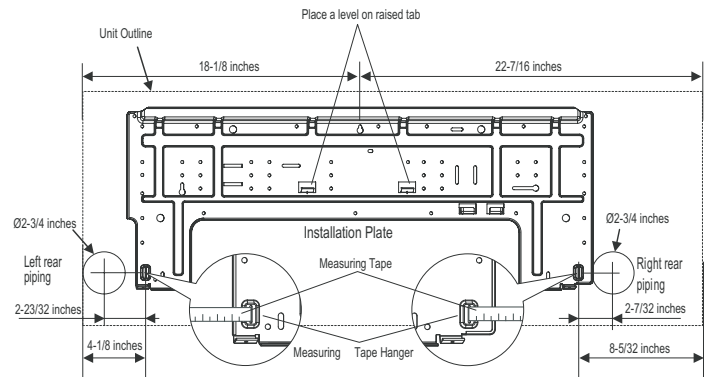


Figure 92: Installation Plate for LSN180HSV4 and LMN247HVT Units.



Note:

If the unit is installed near a body of water, certain components are at risk of being corroded. Appropriate anti-corrosion methods should be taken for the unit and all components.

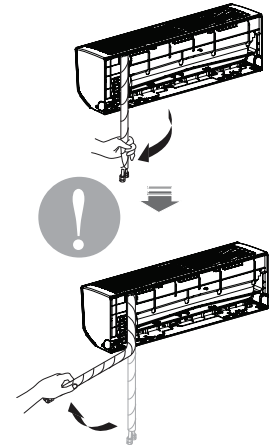
Preparing for Installation

Prepare the refrigerant piping and drain hose (indoor unit piping) for installation through the wall: press on the top of the tubing clamp and slowly guide the piping / hose down (depending on installation requirements, then to the left or right). Relock the tubing clamp after the piping / hose are released.

Note:

Do not bend the piping / drain hose from side to side, it may damage the components.

Figure 93: Preparing for Installation.



Hanging the Indoor Unit Frame

1. Attach the three (3) hooks on the top of the indoor unit to the top edge of the installation plate. Verify the hooks are properly attached to the installation plate by gently shaking the indoor unit from side to side.
2. Unlock the tubing clamp from the indoor unit frame. For easier access between the bottom of the indoor unit and the wall, prop the clamp between the indoor unit frame and installation plate.
3. Remove the screw covers at the bottom of the indoor unit, unscrew the two (2) screws, remove the frame cover, remove the piping connection cover, and position the piping for installation (down, back, left, or right).

Figure 94: Locking the Indoor Unit onto the Installation Plate.

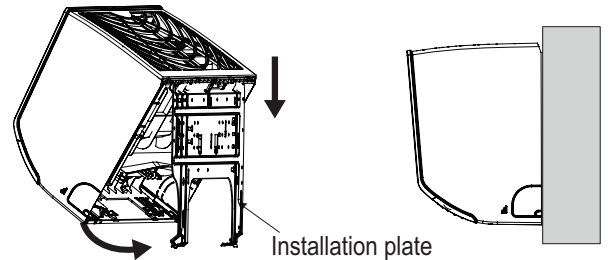


Figure 95: Accessing the Back of the Indoor Unit.

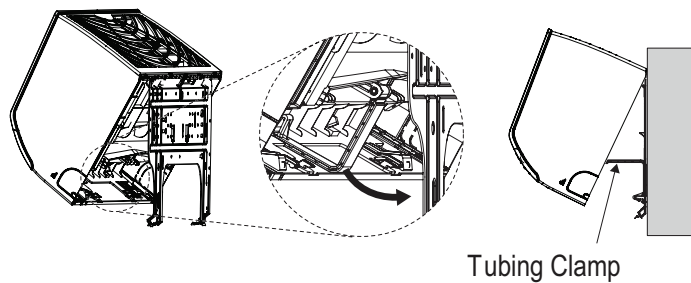


Figure 96: Removing the Frame Cover.

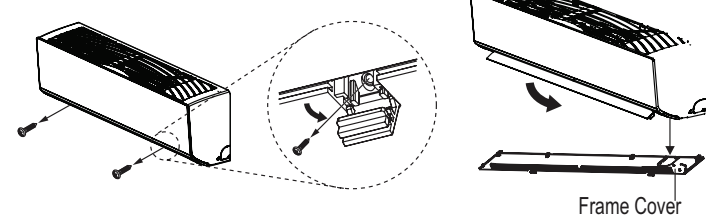


Figure 97: Exterior Back View of Indoor Unit.

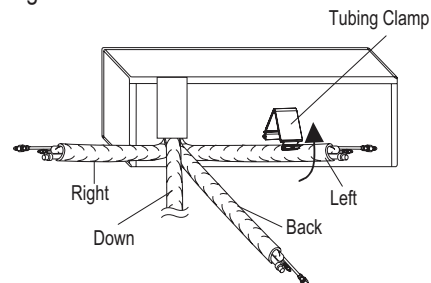


Figure 98: Piping Installed to the Left.

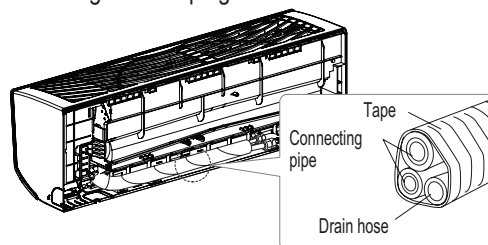
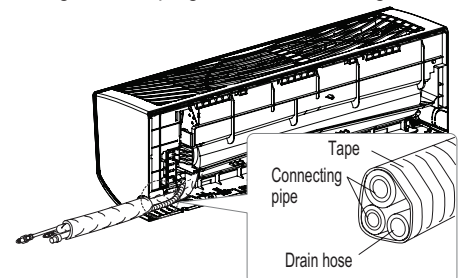


Figure 99: Piping Installed to the Right.



STANDARD WALL-MOUNTED INDOOR UNITS

Installation and Best Layout Practices

MULTI F
MULTI F MAX

Connecting the Indoor Unit Piping to the Field-Installed Piping

1. Center align the indoor unit piping (refrigerant and drain) and the field-installed piping, then hand tighten the flare nut.
2. Tighten the flare nut with a torque wrench.
3. Attach the drain tube piping to the indoor unit drain hose as shown.

Figure 100: Indoor Unit to Field-Installed Piping Connection.

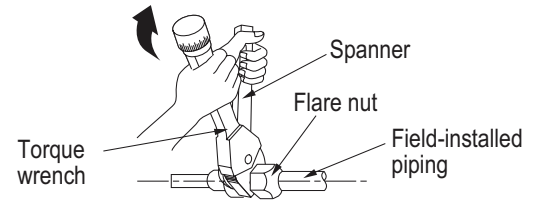
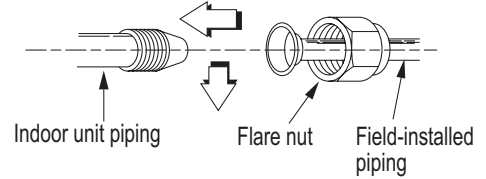
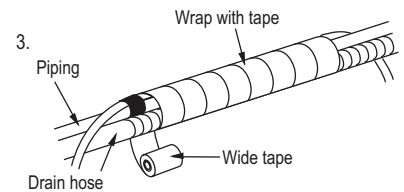
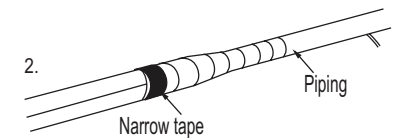
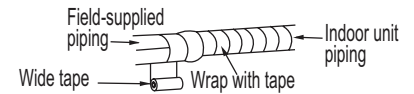
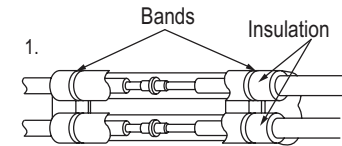


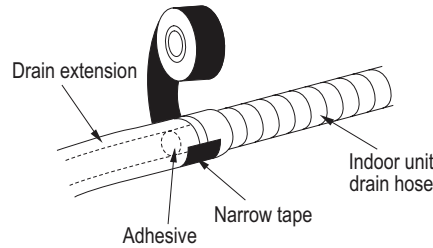
Figure 102: Insulating the Piping.



Note:

If the drain hose is routed inside a room, add insulation to prevent condensation from forming.

Figure 101: Extending the Drain Hose.



Insulating the Refrigerant and Drain Piping

Refrigerant Piping Insulation

Field-installed vapor and liquid refrigerant piping lines must be properly and completely covered in insulation (up to the indoor unit piping connections). Any exposed piping may generate condensate or will cause burns if touched. Insulation for this field-installed refrigerant piping must have a minimum heat resistance of 248°F.

Drain Piping Insulation

Drain piping must have insulation a minimum of 7/32 inches thick.

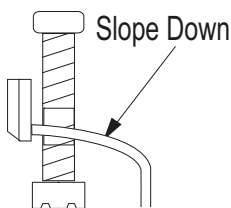
Installing the Insulation

1. Overlap the insulation at the connection of the field-installed piping and the indoor unit piping. Tape together so that no gaps exist.
2. Secure insulation to the rear piping housing section with vinyl tape.
3. Bundle the piping and drain hose with tape where they meet at the back of the indoor unit frame. Position the drain hose at the bottom of the bundle (positioning the drain hose at the top of the bundle may cause the drain pan to overflow inside the indoor unit).

Drain Slope

Drain hose should point down so water can flow away easily.

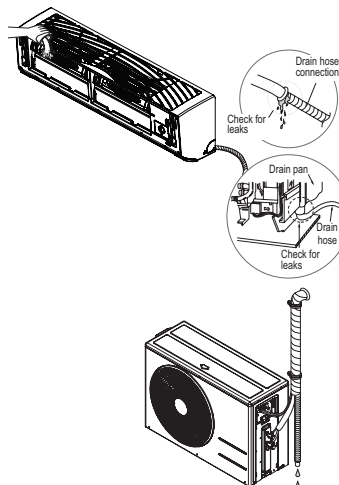
Figure 103: Drain Piping Slope.



Checking the Drainage System

1. Pour water on the indoor unit evaporator.
2. Ensure the water flows through and out of the hose and away from the indoor unit without leaking.

Figure 104: Checking the Drainage System.



Power Wiring / Communications Cable Guidelines

- Follow manufacturer's circuit diagrams in the technical manuals.
- Confirm power source specifications.
- Confirm that the electrical capacity is sufficient.
- Starting current must be maintained ± 10 percent of the rated current marked on the outdoor unit name plate.
- Confirm cable thickness specifications.
- It is recommended that a circuit breaker is installed, especially if conditions could become wet or moist.
- Include a disconnect in the power wiring system, add an air gap contact separation of at least 1/8 inch in each active (phase) conductor.

⚠ WARNING

- Loose wiring may cause unit malfunction, or the terminal to overheat and catch fire.
 - Terminal screws may become loose during transport. Properly tighten the terminal connections during installation.
- A voltage drop may cause the following problems:
- Magnetic switch vibration, fuse breaks, or disturbance to the normal function of an overload protection device.
 - Compressor will not receive the proper starting current.

Connect Power Wiring and Communications Cable

1. Insert the power wiring / communications cable from the outdoor unit or branch distribution unit (Multi F MAX systems only) through the bottom of the indoor unit.
2. Connect each wire to its appropriate terminal on the indoor unit control board. Verify that the color and terminal numbers from the outdoor unit or branch distribution unit (Multi F MAX systems only) wiring match the color and terminal numbers on the indoor unit.
3. Secure power wiring/communications cable with cable restraint.

Figure 105: Connecting Power Wiring / Communications Cable.

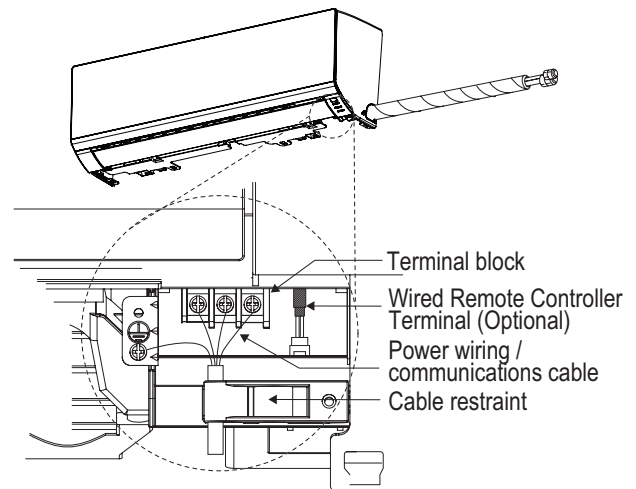


Figure 106: Simplified View of Indoor Unit to Outdoor Unit / Branch Distribution Unit Terminal Connections—LMN077HVT and LMN157HVT.

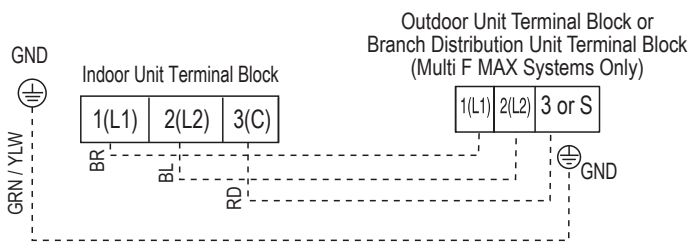


Figure 107: Simplified View of Indoor Unit to Outdoor Unit / Branch Distribution Unit Terminal Connections—LMN247HVT.

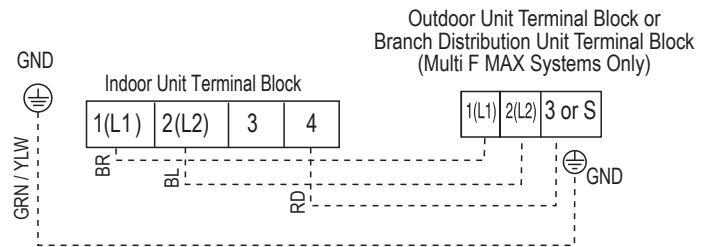


Figure 108: Simplified View of Indoor Unit to Outdoor Unit / Branch Distribution Unit Terminal Connections—LSN090HSV4 and LSN120HSV4.

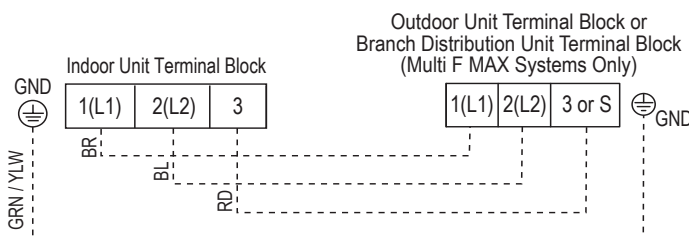
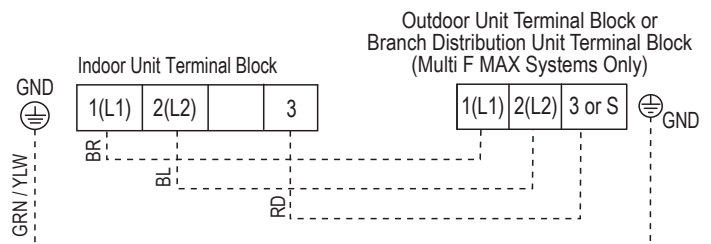


Figure 109: Simplified View of Indoor Unit to Outdoor Unit / Branch Distribution Unit Terminal Connections—LSN180HSV4.



STANDARD WALL-MOUNTED INDOOR UNITS

Installation and Best Layout Practices

MULTI F
MULTI F MAX

Controller Options

Standard wall-mounted indoor units include a wireless controller (AKB73635606), but optional LG-supplied wired controllers are available (see Controls and Options overview on pages 9 to 12 in this manual's Introduction section).

Wireless Controller

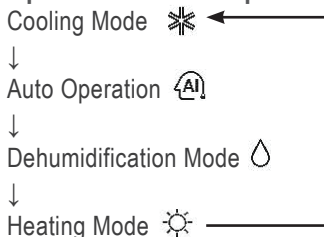
Figure 110: AKB73635606 Wireless Controller.



Table 39: AKB73635606 Wireless Controller Functions.

Control Panel Button	Display Screen	Description
PLASMA		Plasma Button: Plasma filter helps remove air impurities.
SLEEP		Sleep Mode Button ¹ : Sets the sleep mode auto operation.
		Temperature Adjustment Buttons: Raises or lowers temperature setpoint in cooling and heating operation.
ON/OFF	-	On / Off Button: Turns the power on/off.
FAN SPEED		Indoor Fan Speed Button: Changes the fan speed.
MODE		Operation mode selection button ¹ : Selects the operation mode. Cooling operation / Auto operation or auto changeover / Dehumidifying operation / Heating operation / Air circulation
JET		Jet Cool / Jet Heat Button ¹ : Warms up or cools down the indoor temperature within a short period.
SWING		Air Flow Direction Button: Adjusts the airflow direction vertically or horizontally.
ROOM TEMP		Temperature Display Button: Displays the room temperature. Press and hold button down for five (5) seconds. Display changes from °C to °F.
ON/OFF		Timer button: Sets the current time and the start / end times.
A/CLEAN, E/SAVING, LIGHT		Navigation / Functions Button ¹ : Adjusts the time and sets the special functions. Auto clean / Operates energy saving cooling / Adjusts the brightness of the indoor unit display
SET CLEAR	-	Set / Clear Button: Sets or cancels functions.
	-	Reset Button: Resets the air conditioner settings.

Operation Mode Sequence



¹Depending on the indoor unit model, some functions may not be supported.

Wireless Controller

Figure 111: AKB73835312 Wireless Controller.

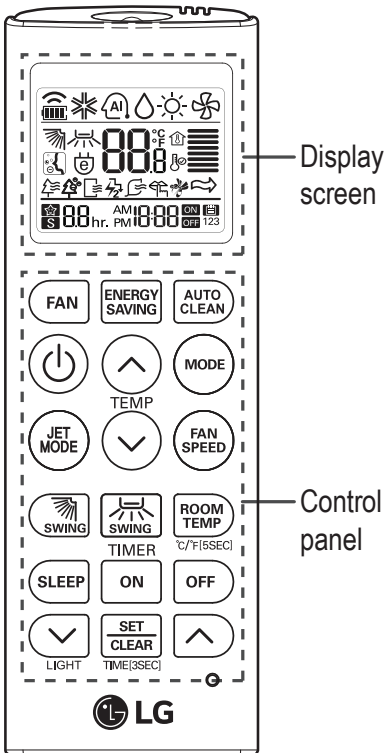


Table 40: AKB73835312 Wireless Controller Functions.

Control panel	Display screen	Description
		Fan button : Air come out from the indoor unit below to the room without air temperature change.
		Sleep mode auto button*: Sets sleep mode auto operation.
		Temperature adjustment buttons: Adjusts the room temperature when cooling and heating.
	-	On/Off button: Turns the power on/off.
		Indoor fan speed button: Adjusts fan speed.
		Operation mode selection button*: Selects the operation mode. Cooling operation (❄️) / Auto operation or auto changeover (🔄) / Dehumidifying operation (💧) / Heating operation (🔥)
		Jet cooling button: Cools the indoor temperature within a short period of time.
		Air flow direction button: Adjusts the air flow direction vertically or horizontally.
	-	Adjusts the brightness of the indoor unit display.
		Temperature display button: Displays the room temperature. Also changes unit from °C to °F if pressed for 5 seconds.
		Timer button: Sets current time and start / end time.
		Navigation and functions button* Selects special functions: 🧹: Auto clean ⏰: Activates energy saving cooling
	-	Set/clear button: Sets or cancels functions.
	-	Reset button: Resets the air conditioner settings.

* Some functions may not be supported, depending on the model.

STANDARD WALL-MOUNTED INDOOR UNITS

Installation and Best Layout Practices

MULTI F
MULTI F MAX

Wired Controller Connections

Figure 112:Wired Controller Connection on the Indoor Unit Terminal Block—LSN090HSV4 and LSN120HSV4 models.

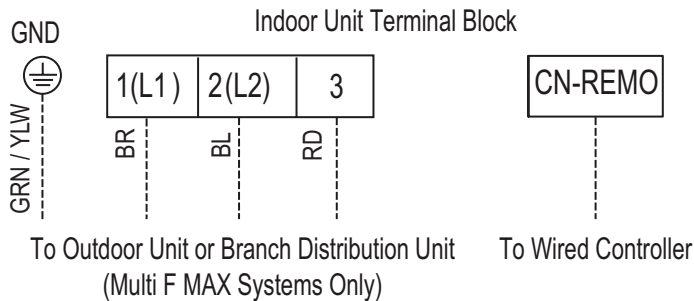


Figure 113:Wired Controller Connection on the Indoor Unit Terminal Block—LSN180HSV4 models.

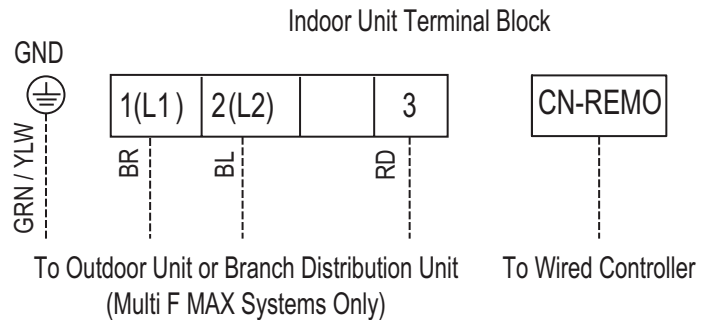


Figure 115:Wired Controller Connection on the Indoor Unit Terminal Block—LMN077HVT and LMN157HVT models.

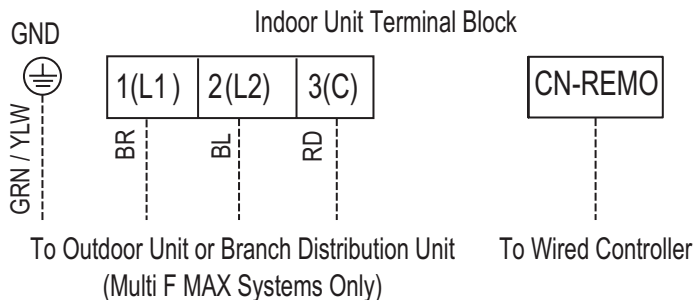
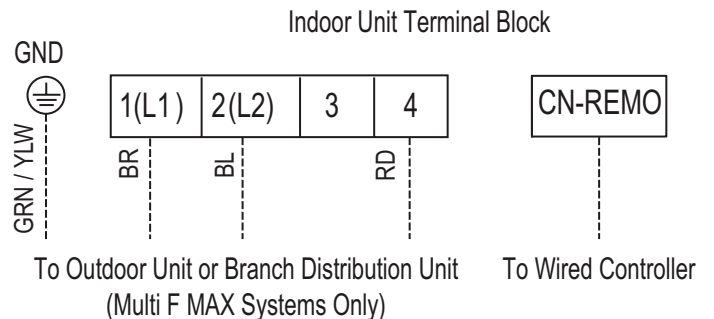


Figure 116:Wired Controller Connection on the Indoor Unit Terminal Block—LMN247HVT models.



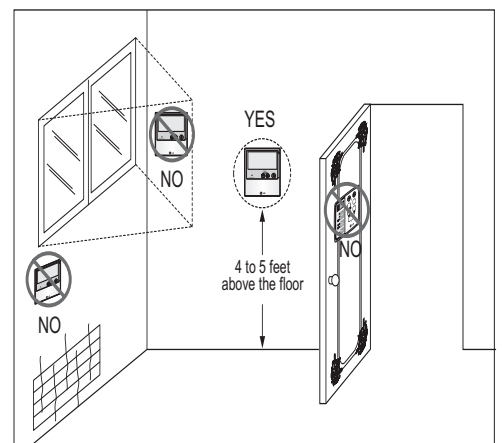
Wired Controller Placement

Wired controllers include a sensor to detect room temperature. To maintain comfort levels in the conditioned space, the wired controller must be installed in a location away from direct sunlight, high humidity, and where it could be directly exposed to cold air. Controller must be installed four (4) to five (5) feet above the floor where its LED display can be read easily, in an area with good air circulation, and where it can detect an average room temperature.

Do not install the wired controller near or in:

- Drafts or dead spots behind doors and in corners
- Hot or cold air from ducts
- Radiant heat from the sun or appliances
- Concealed pipes and chimneys
- An area where temperatures are uncontrolled, such as an outside wall

Figure 114:Proper Location for the Wired Controller.



Hanging the Wired Controller

1. The controller wiring / cable can be installed in one of three directions: top, back, or on the right side. If top or right side installation is desired, remove cable guide grooves on the controller, and then position wiring / cable on applicable side.
2. Choose and mark the area of installation, and then screw the wall plate into place (using the provided parts). Install the controller wall plate to fit the electrical box if one is present. Ensure that no gaps exist between the wall plate and the wall itself.
3. Arrange wiring / cables so as not to interfere with the controller circuitry. Position the wired controller on the wall plate. Snap into place by pressing the bottom part of the wired controller onto the wall plate. Make sure that no gaps exist between the wired controller and the wall plate on all sides.
4. To remove wired controller from the wall plate, insert a screwdriver into the two holes at the bottom. Twist screwdriver to release controller. Do not damage the controller components when removing.

Figure 118: Removing the Cable Guide Grooves.

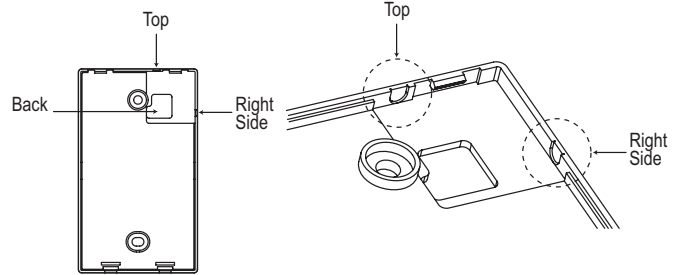


Figure 119: Attaching the Wall Plate.

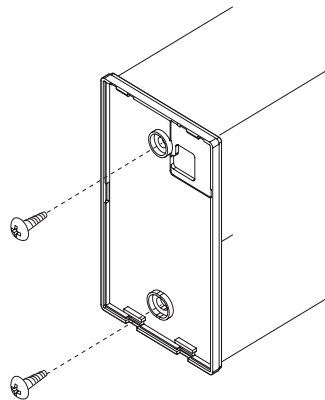
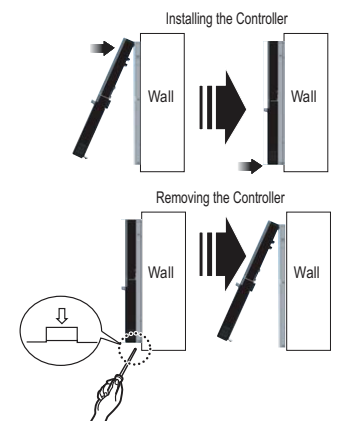


Figure 120: Installing / Removing the Controller.



Assigning the Thermistor for Temperature Detection

Each indoor unit includes a return air thermistor assigned to sense the temperature. If a wired controller is installed, there is a choice of sensing temperature with either the indoor unit return air thermistor or the thermistor in the wired controller. It is also an option to set both thermistors to sense temperature so that indoor unit bases its operation on the first thermistor to reach the designated temperature differential. For applicable indoor units, an optional Remote Temperature Sensor can be used in lieu of the return air thermistor—either alone or in conjunction with a wired controller thermistor as previously described.

Finalizing Indoor Unit Installation

1. Move the tubing clamp to its original position.
2. Ensure the three (3) hooks are properly attached to the installation plate by gently shaking the indoor unit from side to side.
3. Press the bottom left and right sides of the indoor unit against the installation plate until the hooks click firmly into their slots.
4. Using two (2) Type “C” screws, secure the bottom of the indoor unit to the installation plate.
5. Remove the two (2) tabs from the filter.
6. Replace the frame cover.

Figure 117: Attach the bottom of the indoor unit to the installation plate.

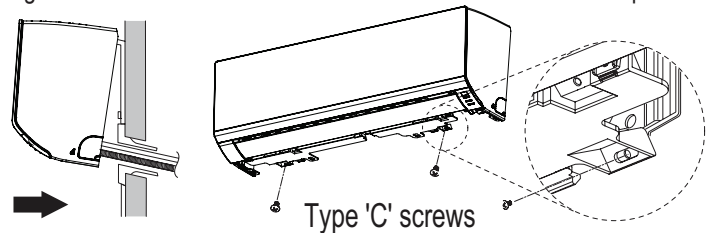
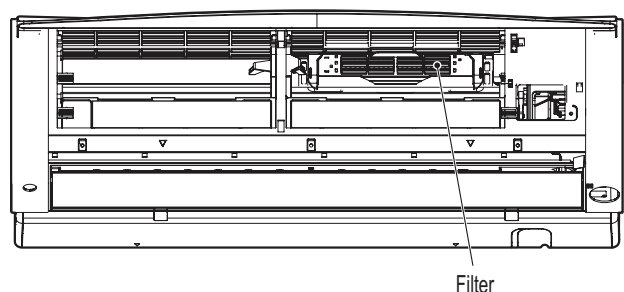


Figure 121: Removing the Filter Tabs.



CEILING-CONCEALED DUCT (LOW STATIC) INDOOR UNIT DATA

“Mechanical Specifications” on page 90

“General Data / Specifications” on page 91

“Dimensions” on page 92

“Cooling Capacity Table” on page 93

“Heating Capacity Table” on page 95

“External Static Pressure” on page 96

“Acoustic Data” on page 97

“Refrigerant Flow Diagram” on page 98

“Wiring Diagram” on page 100

“Factory Supplied Parts and Materials” on page 101

“Installation and Best Layout Practices” on page 102

DUCT (LOW STATIC) INDOOR UNITS

Mechanical Specifications and Features

MULTI F
MULTI F MAX

Ceiling-Concealed Duct (Low Static) Indoor Unit

General

All LG indoor units are factory assembled, wired, piped, and provided with a control circuit board, fan, and motor. Ceiling-Concealed Duct (Low Static) units have a sound rating no higher than 36 dB(A) as tested per KSA0701 ISO Standard 3745, and are designed for low-static pressure up to 0.20"WG.

Coil

Indoor unit coils are factory built and are comprised of aluminum fins mechanically bonded to copper tubing. Each unit has two rows of coils, which are pressure tested at the factory. Each unit is provided with a factory installed condensate drain pan below the coil.

Refrigerant System

System is designed for use with R410A refrigerant. The refrigeration circuit is pressure-tested at the factory and shipped with a holding charge of helium gas. Refrigerant pipe connections are 45° flare, and all refrigerant lines from the outdoor unit to the indoor units must be field insulated.

Electrical

Each indoor unit is designed to operate using 208–230/60/1 power with voltage variances of $\pm 10\%$.

Casing

The case has a low profile design with a maximum height of 7.5 inches designed to mount fully concealed above a finished ceiling in as little as 8 inches vertical space. Casing is manufactured of galvanized steel plate, and provided with hanger brackets designed to support the weight on four corners. Unit has a front horizontal supply air discharge outlet, and one rear horizontal return air inlet; unit is also field-convertible for a rear bottom return.

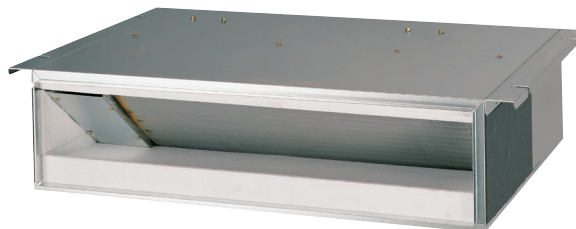
Fan Assembly and Control

The units have at least two direct-drive, Sirocco fans made of high strength ABS HT-700 polymeric resin that are statically and dynamically balanced. The fans are mounted on a common brushless digitally controlled (BLDC) motor with permanently lubricated and sealed ball bearings. The fan / motor assembly is mounted on vibration-attenuating rubber grommets. Fan speed is controlled using a microprocessor-based direct digital control algorithm. The indoor fan has Low, Med, High, and Auto settings for Cooling mode; and

Features

- Inverter (Variable speed fan)
- External mounted drain pump
- Control lock function
- Auto operation
- Auto restart operation
- Dehumidification function
- Two thermistor control
- External static pressure control
- Self-diagnostics function
- Group control
- Wired thermostat included

Figure 122: Ceiling-Concealed Duct (Low Static) Indoor Unit.



has Low, Med, High, and Auto settings for Heating mode. Each of the settings can be field-adjusted from the factory setting (RPM / ESP). The Auto setting adjusts the fan speed based on the difference between the controller set-point and space temperature.

Air Filter

Return air is filtered with a factory-supplied, removable, washable filter accessible from the rear of the indoor unit.

Microprocessor Control

The unit is provided with an integrated control panel to communicate with the outdoor unit. All unit operation parameters are stored in non-volatile memory residing on the unit microprocessor. The microprocessor controls space temperature through using the value provided by the temperature sensor within the indoor unit. The microprocessor control will activate indoor unit operation when the indoor room temperature falls below or rises above a setpoint temperature, at which point, a signal is sent to the outdoor unit to begin the appropriate mode. The microprocessor will also provide self-diagnostics and auto restart functions. A field-supplied four-wire power / communications cable must be installed to connect the indoor unit(s) to the outdoor unit.

Controls

The indoor unit is supplied with an LG wired controller. Communication between the indoor units and the outdoor unit is accomplished through 18 AWG, four-core, stranded and shielded power / communication cable.

Condensate Lift/Pump

The indoor unit is provided with an externally mounted, factory installed and wired condensate lift/pump capable of providing a minimum 27.5 inch lift from the bottom surface of the unit. Drain pump has a safety switch to shut off the indoor unit if the condensate rises too high in the drain pan.

Table 41: Multi F Ceiling-Concealed Low-Static Ducted Indoor Unit General Data.

Model Name	LMDN096HV	LMDN126HV	LMDN186HV
Nominal Cooling Capacity (Btu/h) ¹	9,000	12,000	18,000
Nominal Heating Capacity (Btu/h) ¹	10,400	13,800	20,800
<i>Operating Range</i>			
Cooling (°F WB)	57-77	57-77	57-77
Heating (°F DB)	59-81	59-81	59-81
<i>Fan</i>			
Type	Sirocco		
Motor Output (W) x Qty.	19 x 1	5 x 1, 19 x 1	
Motor/Drive	Brushless Digitally Controlled / Direct		
Airflow Rate CFM (H/M/L)	318 / 247 / 194	353 / 300 / 247	530 / 441 / 353
Factory Set External Static Pressure (in. wg)	0.10		
Max. External Static Pressure (in. wg)	0.20		
<i>Unit Data</i>			
Refrigerant Type ²	R410A		
Refrigerant Control	EEV		
Power Supply V, Ø, Hz ³	208-230, 1, 60		
Rated Amps (A)	0.40	0.80	
Sound Pressure Level ±3 dB(A) (H/M/L) ⁴	30 / 26 / 23	31 / 28 / 27	36 / 34 / 31
Dimensions (W x H x D, in.)	27-9/16 x 7-15/32 x 27-9/16	35-7/16 x 7-15/32 x 27-9/16	
Net Unit Weight (lbs.)	39	51	
Shipping Weight (lbs.)	45	57	
Power Wiring / Communications Cable (No. x AWG) ⁵	4 x 18	4 x 18	4 x 18
Heat Exchanger (Row x Column x Fin / inch) x Number	(2 x 11 x 14) x 1	(2 x 11 x 18) x 1	
<i>Piping</i>			
Liquid (in.)	1/4		
Vapor (in.)	3/8		1/2
Drain O.D. / I.D. (in.)	1-1/4, 1		

¹Nominal capacity is rated 0 ft. above sea level with corresponding refrigerant piping length in accordance with standard length of each outdoor unit and a 0 ft. level difference between outdoor and indoor units. All capacities are net with a combination ratio between 95 – 105%.

Nominal cooling capacity rating obtained with air entering the indoor unit at 80°F dry bulb (DB) and 67°F wet bulb (WB) and outdoor ambient conditions of 95°F dry bulb (DB) and 75°F wet bulb (WB).
Nominal heating capacity rating obtained with air entering the indoor unit at 70°F dry bulb (DB) and 60°F wet bulb (WB) and outdoor ambient conditions of 47°F dry bulb (DB) and 43°F wet bulb (WB).

²This unit comes with a dry helium charge.

³Acceptable operating voltage: 187V-253V.

⁴Sound pressure levels are tested in an anechoic chamber under ISO Standard 3745 and are the same in both cooling and heating mode. These values can increase due to ambient conditions during operation.

⁵All power wiring / communications cables to be minimum 18 AWG, 4-conductor, stranded, shielded, and must comply with applicable local and national codes.

DUCT (LOW STATIC) INDOOR UNITS

Dimensions

MULTI F
MULTI F MAX

Figure 123:LMDN096HV, LMDN126HV, and LMDN186HV Dimensions.

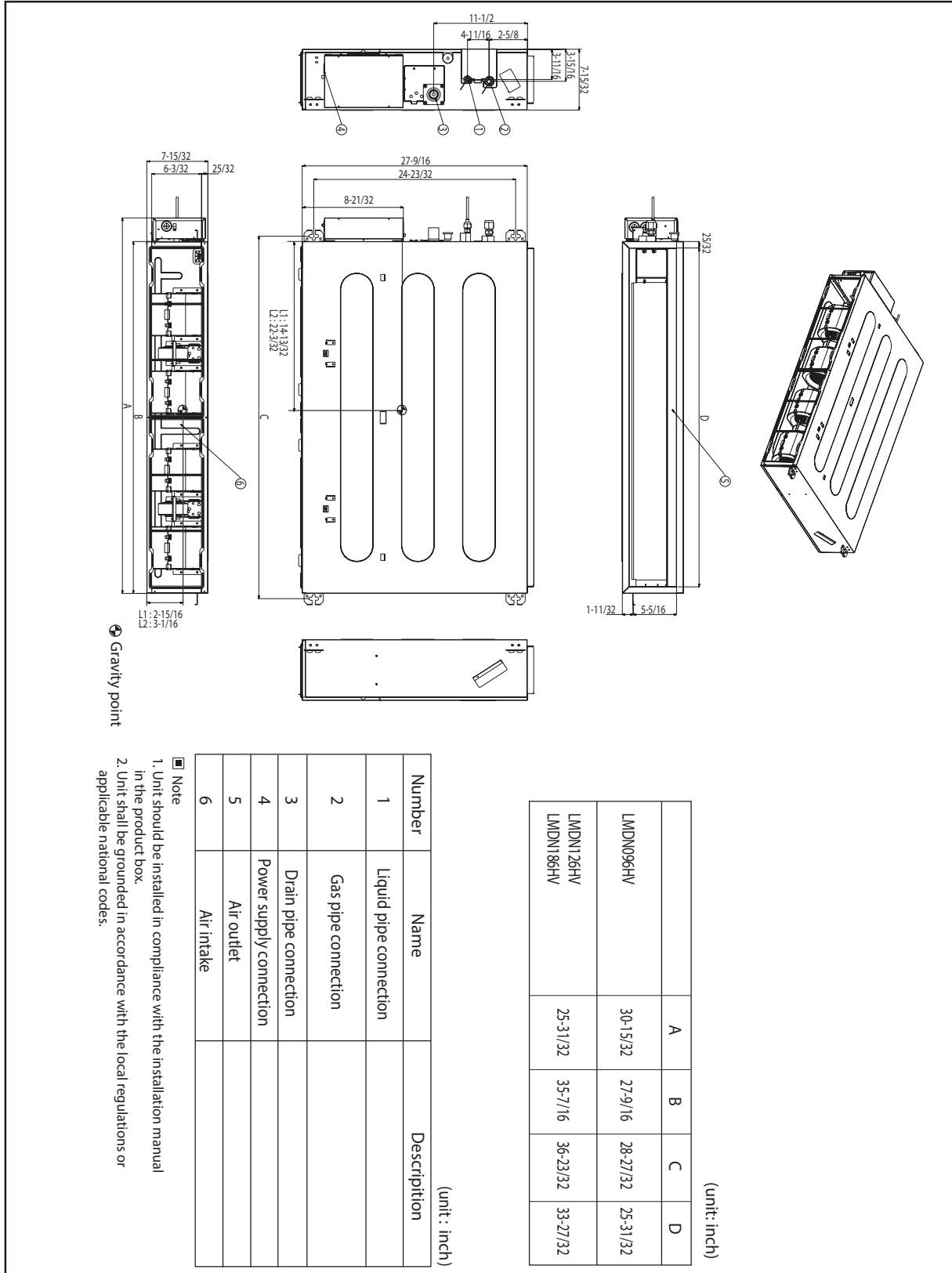


Table 42: Multi F Ceiling-Concealed Duct (Low Static) Indoor Units Cooling Capacity Table.

Model No. / Nominal Capacity of Indoor Unit (Btu/h)	Outdoor Air Temp. (°F DB)	Indoor Air Temp. °F DB / °F WB											
		68 / 57		73 / 61		77 / 64		80 / 67		86 / 72		90 / 75	
		TC	SHC	TC	SHC	TC	SHC	TC	SHC	TC	SHC	TC	SHC
LMDN096HV 9,000	14	8.82	7.55	9.37	7.98	9.92	7.72	10.31	7.89	11.01	7.95	11.56	8.10
	20	8.82	7.61	9.36	8.04	9.91	7.78	10.31	7.95	11.01	8.01	11.55	8.17
	25	8.81	7.67	9.36	8.10	9.90	7.84	10.30	8.01	11.00	8.08	11.54	8.23
	30	8.80	7.73	9.35	8.16	9.90	7.90	10.29	8.07	10.99	8.14	11.54	8.29
	35	8.80	7.79	9.34	8.22	9.89	7.96	10.28	8.13	10.98	8.20	11.53	8.36
	40	8.79	7.84	9.33	8.29	9.88	8.02	10.27	8.19	10.97	8.26	11.52	8.42
	45	8.78	7.90	9.33	8.35	9.87	8.08	10.27	8.25	10.96	8.32	11.51	8.48
	50	8.78	7.96	9.32	8.41	9.87	8.14	10.26	8.31	10.96	8.38	11.50	8.54
	55	8.77	8.02	9.31	8.47	9.86	8.20	10.25	8.38	10.95	8.45	11.49	8.61
	60	8.76	8.08	9.31	8.53	9.85	8.26	10.24	8.44	10.94	8.51	11.48	8.67
	65	8.76	8.14	9.30	8.59	9.84	8.32	10.24	8.50	10.93	8.57	11.47	8.73
	70	8.75	8.19	9.29	8.66	9.84	8.38	10.23	8.56	10.92	8.63	11.47	8.79
	75	8.54	8.06	9.08	8.52	9.62	8.26	10.01	8.44	10.71	8.53	11.25	8.69
	80	8.33	7.92	8.87	8.39	9.41	8.14	9.80	8.33	10.49	8.42	11.03	8.59
	85	8.12	7.78	8.66	8.25	9.20	8.02	9.59	8.20	10.28	8.30	10.82	8.48
	90	7.91	7.63	8.45	8.10	8.99	7.89	9.37	8.08	10.06	8.19	10.60	8.37
	95	7.68	7.55	8.22	8.03	8.75	7.83	9.00	7.90	9.83	8.14	10.36	8.34
	100	7.50	7.35	8.03	7.83	8.57	7.64	8.88	7.78	9.64	7.97	10.17	8.16
105	7.31	7.15	7.84	7.63	8.38	7.45	8.77	7.66	9.45	7.79	9.99	7.99	
110	7.12	6.90	7.66	7.38	8.19	7.22	8.58	7.43	9.26	7.57	9.80	7.77	
115	6.94	6.69	7.47	7.17	8.01	7.03	8.39	7.24	9.08	7.39	9.61	7.60	
118	6.82	6.65	7.36	7.13	7.89	7.00	8.28	7.21	8.96	7.37	9.50	7.58	
122	6.79	6.63	7.32	7.11	7.86	6.98	8.24	7.19	8.93	7.36	9.46	7.57	
LMDN126HV 12,000	14	11.76	9.94	12.49	10.50	13.22	10.17	13.75	10.38	14.69	10.47	15.42	10.67
	20	11.75	10.02	12.48	10.58	13.21	10.25	13.74	10.46	14.67	10.55	15.40	10.75
	25	11.75	10.09	12.48	10.66	13.20	10.33	13.73	10.54	14.66	10.63	15.39	10.83
	30	11.74	10.17	12.47	10.75	13.19	10.40	13.72	10.62	14.65	10.71	15.38	10.92
	35	11.73	10.25	12.46	10.83	13.18	10.48	13.71	10.70	14.64	10.79	15.37	11.00
	40	11.72	10.33	12.45	10.91	13.17	10.56	13.70	10.79	14.63	10.88	15.36	11.08
	45	11.71	10.40	12.44	10.99	13.16	10.64	13.69	10.87	14.62	10.96	15.35	11.16
	50	11.70	10.48	12.43	11.07	13.15	10.72	13.68	10.95	14.61	11.04	15.33	11.25
	55	11.69	10.56	12.42	11.15	13.14	10.80	13.67	11.03	14.60	11.12	15.32	11.33
	60	11.68	10.63	12.41	11.23	13.13	10.88	13.66	11.11	14.59	11.20	15.31	11.41
	65	11.67	10.71	12.40	11.31	13.12	10.96	13.65	11.19	14.57	11.28	15.30	11.49
	70	11.66	10.79	12.39	11.40	13.11	11.03	13.64	11.27	14.56	11.36	15.29	11.58
	75	11.38	10.61	12.11	11.22	12.83	10.88	13.35	11.12	14.27	11.22	15.00	11.45
	80	11.10	10.43	11.82	11.05	12.55	10.72	13.07	10.96	13.99	11.08	14.71	11.31
	85	10.83	10.24	11.54	10.86	12.26	10.55	12.78	10.80	13.70	10.93	14.42	11.17
	90	10.55	10.04	11.26	10.67	11.98	10.38	12.50	10.63	13.42	10.78	14.13	11.02
	95	10.25	9.94	10.96	10.57	11.67	10.30	12.00	10.40	13.10	10.72	13.81	10.97
	100	10.00	9.67	10.71	10.31	11.42	10.06	11.84	10.24	12.85	10.49	13.56	10.75
105	9.75	9.41	10.46	10.04	11.17	9.81	11.69	10.08	12.60	10.26	13.31	10.52	
110	9.50	9.09	10.21	9.72	10.92	9.51	11.44	9.78	12.35	9.97	13.07	10.24	
115	9.25	8.81	9.96	9.44	10.67	9.26	11.19	9.53	12.10	9.73	12.82	10.00	
118	9.10	8.75	9.81	9.39	10.52	9.21	11.04	9.49	11.95	9.70	12.67	9.98	
122	9.05	8.73	9.76	9.37	10.48	9.19	10.99	9.47	11.90	9.69	12.62	9.97	

TC = Total Capacity (kBtu/h).

SHC: Sensible Heat Capacity (kBtu/h).

Nominal capacity as rated 0 ft. above sea level and a 0 ft. level difference between outdoor and indoor units. Corresponding refrigerant piping length is accordance with standard length of each outdoor unit.

Nominal cooling capacity rating obtained with air entering the indoor unit at 80°F dry bulb (DB) and 67°F wet bulb (WB), and outdoor ambient conditions of 95°F dry bulb (DB) and 75°F wet bulb (WB).

The shaded table columns and rows indicate reference data. When operating at this temperature, these values can be different if the system is not running consistently.

Ceiling-Concealed Duct (Low Static)

DUCT (LOW STATIC) INDOOR UNITS

Cooling Capacity Table

MULTI F
MULTI F MAX

Table 43: Multi F Ceiling-Concealed Duct (Low Static) Indoor Units Cooling Capacity Table (continued).

Model No. / Nominal Capacity of Indoor Unit (Btu/h)	Outdoor Air Temp. (°F DB)	Indoor Air Temp. °F DB / °F WB											
		68 / 57		73 / 61		77 / 64		80 / 67		86 / 72		90 / 75	
		TC	SHC	TC	SHC	TC	SHC	TC	SHC	TC	SHC	TC	SHC
LMDN186HV 18,000	14	17.65	13.09	18.74	13.83	19.84	13.39	20.63	13.67	22.03	13.79	23.12	14.05
	20	17.63	13.20	18.73	13.94	19.82	13.50	20.61	13.78	22.01	13.90	23.11	14.16
	25	17.62	13.30	18.71	14.05	19.81	13.60	20.60	13.89	22.00	14.01	23.09	14.27
	30	17.60	13.40	18.70	14.16	19.79	13.71	20.58	13.99	21.98	14.11	23.07	14.38
	35	17.59	13.50	18.68	14.26	19.78	13.81	20.57	14.10	21.96	14.22	23.05	14.49
	40	17.58	13.60	18.67	14.37	19.76	13.91	20.55	14.21	21.94	14.33	23.04	14.60
	45	17.56	13.71	18.66	14.48	19.75	14.02	20.53	14.31	21.93	14.43	23.02	14.71
	50	17.55	13.81	18.64	14.58	19.73	14.12	20.52	14.42	21.91	14.54	23.00	14.82
	55	17.54	13.91	18.63	14.69	19.72	14.23	20.50	14.52	21.89	14.65	22.98	14.92
	60	17.52	14.01	18.61	14.80	19.70	14.33	20.49	14.63	21.88	14.75	22.97	15.03
	65	17.51	14.11	18.60	14.90	19.69	14.43	20.47	14.74	21.86	14.86	22.95	15.14
	70	17.50	14.21	18.58	15.01	19.67	14.53	20.46	14.84	21.84	14.97	22.93	15.25
	75	17.08	13.98	18.16	14.78	19.24	14.33	20.03	14.64	21.41	14.78	22.50	15.08
	80	16.66	13.74	17.74	14.55	18.82	14.12	19.60	14.44	20.98	14.60	22.06	14.90
	85	16.24	13.49	17.32	14.30	18.40	13.90	19.17	14.23	20.55	14.40	21.63	14.71
	90	15.82	13.23	16.90	14.06	17.97	13.68	18.75	14.01	20.12	14.20	21.20	14.52
	95	15.37	13.09	16.44	13.93	17.51	13.57	18.00	13.70	19.65	14.12	20.72	14.46
	100	14.99	12.74	16.06	13.58	17.13	13.25	17.77	13.49	19.28	13.82	20.35	14.16
	105	14.62	12.39	15.69	13.23	16.76	12.93	17.53	13.28	18.90	13.52	19.97	13.86
	110	14.24	11.97	15.32	12.80	16.39	12.53	17.16	12.88	18.53	13.13	19.60	13.48
115	13.87	11.61	14.94	12.44	16.01	12.19	16.79	12.55	18.15	12.82	19.22	13.18	
118	13.65	11.53	14.72	12.36	15.79	12.13	16.56	12.50	17.93	12.77	19.00	13.14	
122	13.57	11.50	14.64	12.34	15.71	12.11	16.49	12.48	17.85	12.76	18.92	13.13	

TC = Total Capacity (kBtu/h).

SHC: Sensible Heat Capacity (kBtu/h).

Nominal capacity as rated 0 ft. above sea level and a 0 ft. level difference between outdoor and indoor units. Corresponding refrigerant piping length is accordance with standard length of each outdoor unit.

Nominal cooling capacity rating obtained with air entering the indoor unit at 80°F dry bulb (DB) and 67°F wet bulb (WB), and outdoor ambient conditions of 95°F dry bulb (DB) and 75°F wet bulb (WB).

The shaded table columns and rows indicate reference data. When operating at this temperature, these values can be different if the system is not running consistently.

Multi F and Multi F MAX Indoor Unit Engineering Manual



Table 44: Multi F Ceiling-Concealed Duct (Low Static) Indoor Units Heating Capacity Table.

Model No. / Nominal Capacity of Indoor Unit (Btu/h)	Outdoor Air Temp.		Indoor Air Temp. °F DB					
	°F DB	°F WB	61	64	68	70	72	75
			TC	TC	TC	TC	TC	TC
LMDN096HV 9,000	0	-0.4	5.35	5.28	5.23	5.20	5.12	4.90
	5	4.5	6.03	5.95	5.90	5.88	5.80	5.58
	10	9	6.71	6.63	6.58	6.56	6.48	6.26
	17	15	7.61	7.54	7.49	7.46	7.39	7.14
	20	19	7.95	7.88	7.83	7.80	7.72	7.46
	25	23	8.52	8.44	8.39	8.37	8.29	7.99
	30	28	9.01	8.93	8.88	8.86	8.78	8.52
	35	32	9.50	9.42	9.37	9.34	9.27	9.04
	40	36	9.94	9.86	9.81	9.78	9.71	9.48
	45	41	10.37	10.30	10.25	10.22	10.15	9.92
	47	43	10.55	10.48	10.43	10.40	10.32	10.10
	50	46	10.72	10.64	10.59	10.57	10.49	10.24
	55	51	11.00	10.93	10.88	10.85	10.78	10.48
	60	56	11.00	10.93	10.88	10.85	10.78	10.52
	63	59	11.00	10.93	10.88	10.85	10.78	10.55
68	64	11.00	10.93	10.88	10.85	10.78	10.60	
LMDN126HV 12,000	0	-0.4	7.10	7.00	6.93	6.90	6.80	6.50
	5	4.5	8.00	7.90	7.83	7.80	7.70	7.40
	10	9	8.90	8.80	8.73	8.70	8.60	8.30
	17	15	10.10	10.00	9.93	9.90	9.80	9.48
	20	19	10.55	10.45	10.38	10.35	10.25	9.90
	25	23	11.30	11.20	11.13	11.10	11.00	10.60
	30	28	11.95	11.85	11.78	11.75	11.65	11.30
	35	32	12.60	12.50	12.43	12.40	12.30	12.00
	40	36	13.18	13.08	13.02	12.98	12.88	12.58
	45	41	13.77	13.67	13.60	13.57	13.47	13.17
	47	43	14.00	13.90	13.83	13.80	13.70	13.40
	50	46	14.23	14.13	14.06	14.03	13.93	13.59
	55	51	14.60	14.50	14.43	14.40	14.30	13.90
	60	56	14.60	14.50	14.43	14.40	14.30	13.96
	63	59	14.60	14.50	14.43	14.40	14.30	14.00
68	64	14.60	14.50	14.43	14.40	14.30	14.06	
LMDN186HV 18,000	0	-0.4	10.70	10.55	10.45	10.40	10.25	9.80
	5	4.5	12.06	11.91	11.81	11.76	11.61	11.15
	10	9	13.41	13.26	13.16	13.11	12.96	12.51
	17	15	15.22	15.07	14.97	14.92	14.77	14.29
	20	19	15.90	15.75	15.65	15.60	15.45	14.92
	25	23	17.03	16.88	16.78	16.73	16.58	15.98
	30	28	18.01	17.86	17.76	17.71	17.56	17.03
	35	32	18.99	18.84	18.74	18.69	18.54	18.09
	40	36	19.87	19.72	19.62	19.57	19.42	18.97
	45	41	20.75	20.60	20.50	20.45	20.30	19.85
	47	43	21.10	20.95	20.85	20.80	20.65	20.20
	50	46	21.44	21.29	21.19	21.14	20.99	20.48
	55	51	22.01	21.86	21.75	21.70	21.55	20.95
	60	56	22.01	21.86	21.75	21.70	21.55	21.04
	63	59	22.01	21.86	21.75	21.70	21.55	21.10
68	64	22.01	21.86	21.75	21.70	21.55	21.20	

TC = Total Capacity (kBtu/h).

Nominal capacity as rated 0 ft. above sea level and a 0 ft. level difference between outdoor and indoor units. Corresponding refrigerant piping length is accordance with standard length of each outdoor unit.

Nominal heating capacity rating obtained with air entering the indoor unit at 70°F dry bulb (DB) and 60°F wet bulb (WB), and outdoor ambient conditions of 47°F dry bulb (DB) and 43°F wet bulb (WB).

Ceiling-Concealed Duct (Low Static)

DUCT (LOW STATIC) INDOOR UNITS

External Static Pressure

MULTI F
MULTI F MAX

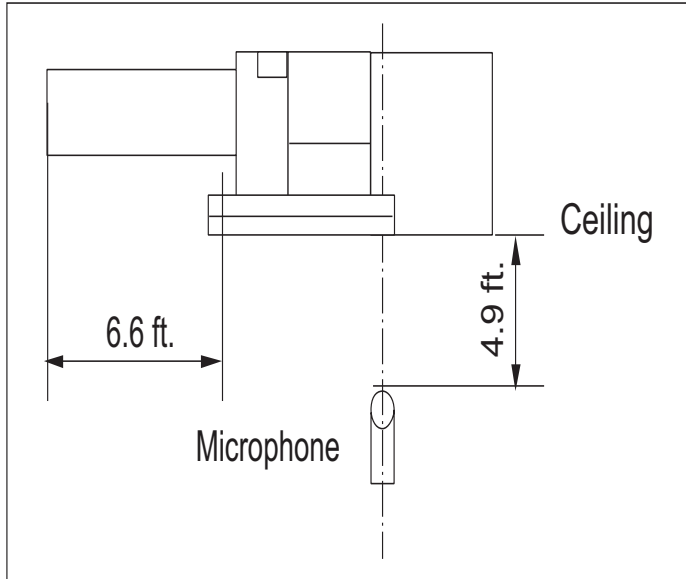
Table 45: Multi F Ceiling-Concealed Duct (Low Static) External Static Pressure Setting Values Table.

Static Pressure (in. wg)			0.0	0.04	0.08	0.12	0.16	0.20
Model No. / Nominal Capacity of Indoor Unit (Btu/h)	Airflow Rate / CFM		Setting Value					
	LMDN096HV 9,000	High	318	98	103	108	116	123
Mid		247	82	88	94	102	110	118
Low		194	69	76	83	91	99	109
LMDN126HV 12,000	High	353	95	99	104	109	116	124
	Mid	300	86	91	96	101	108	116
	Low	247	78	82	87	93	100	108
LMDN186HV 18,000	High	530	123	125	129	134	141	145
	Mid	441	109	112	117	123	129	136
	Low	353	95	99	104	109	116	124

Note:

- To get the desired air flow and external static pressure combination, use the setting value from the table. Using a setting value other than that listed in the table will not provide the desired combination.
- Table data is based at 230V. Air flow rate varies according to voltage fluctuation.

Figure 124: Sound Pressure Level Measurement Location.

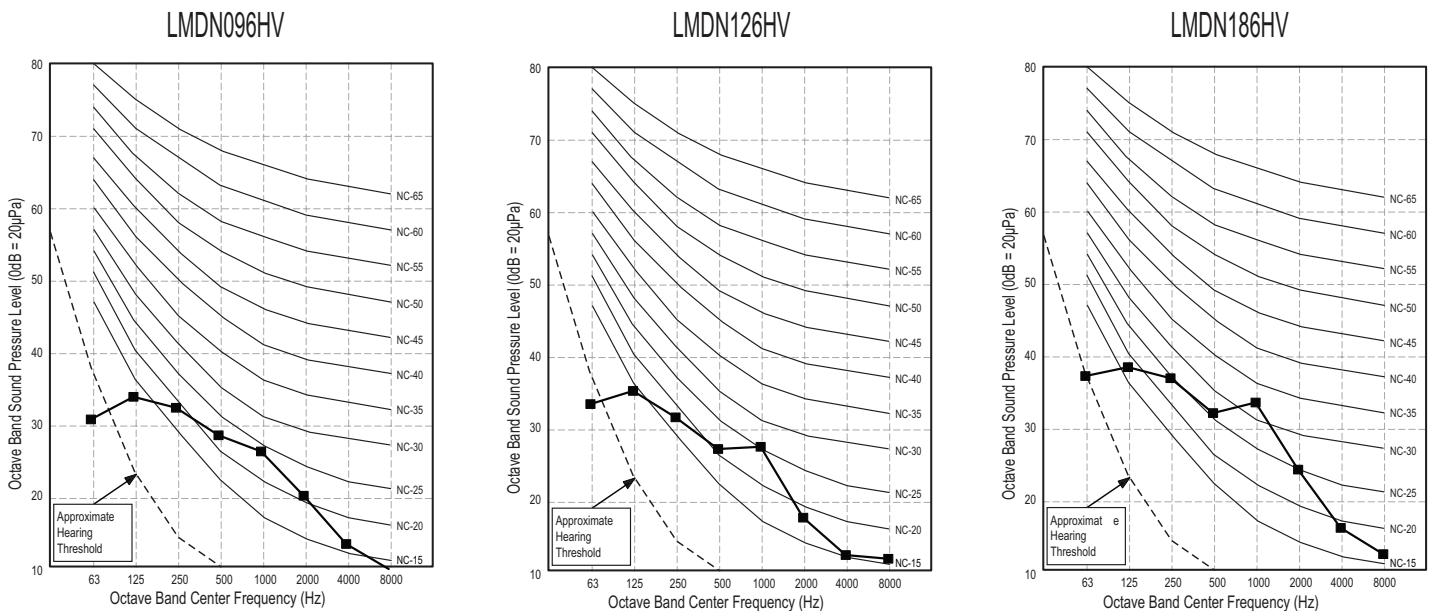


- Measurements taken with no attenuation and units operating at full load normal operating condition.
- Sound level will vary depending on a range of factors such as construction (acoustic absorption coefficient) of particular area in which the equipment is installed.
- Sound power levels are measured in dB(A)±3.
- Tested in anechoic chamber per ISO Standard 3745.

Table 46: Sound Pressure Levels (dB[A]).

Model No.	Sound Pressure Levels (dB[A]) (Cooling and Heating)		
	High Fan Speed	Medium Fan Speed	Low Fan Speed
LMDN096HV	30	26	23
LMDN126HV	31	28	27
LMDN186HV	36	34	31

Figure 125: Sound Pressure Level Diagrams.



DUCT (LOW STATIC) INDOOR UNITS

Refrigerant Flow Diagrams

MULTI F
MULTI F MAX

Figure 126: LMDN096HV Refrigerant Flow Diagram.

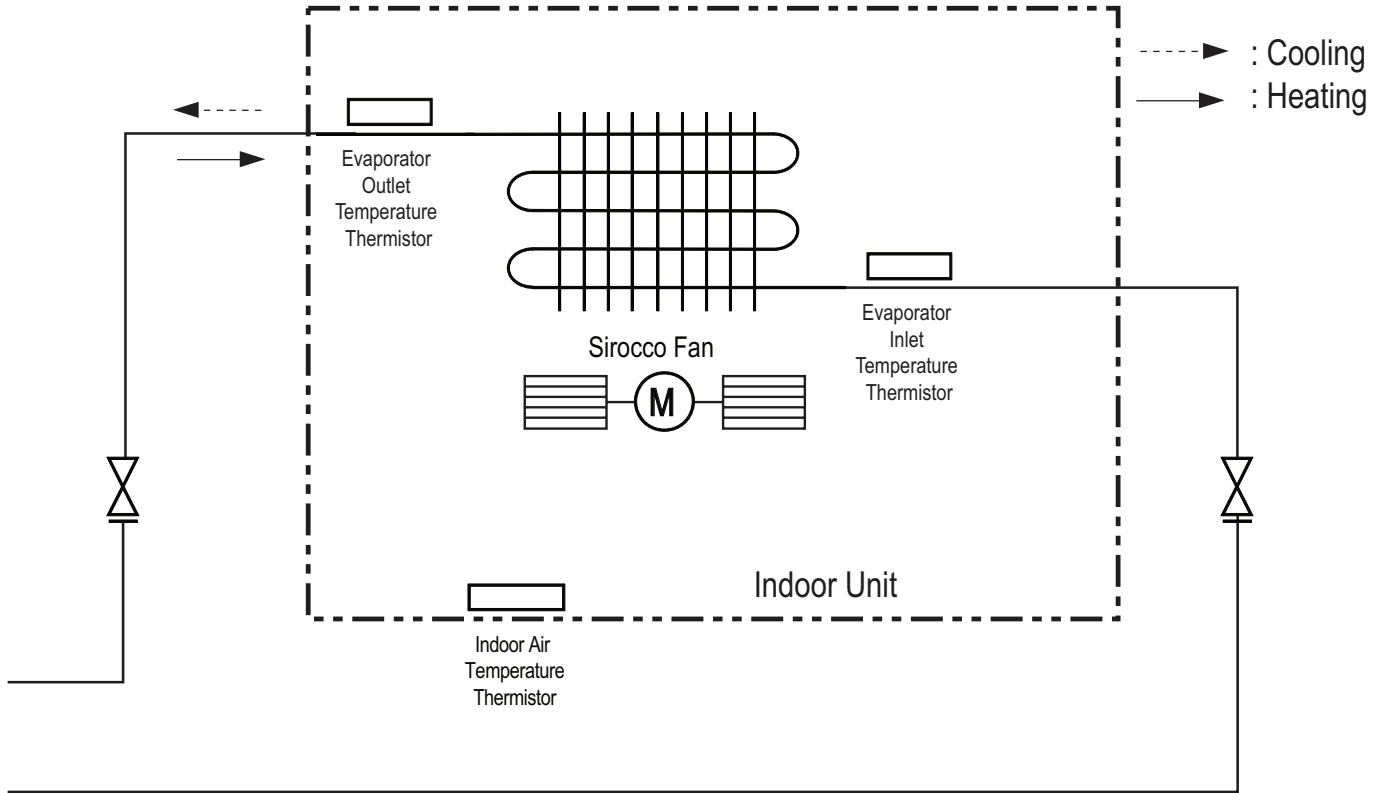


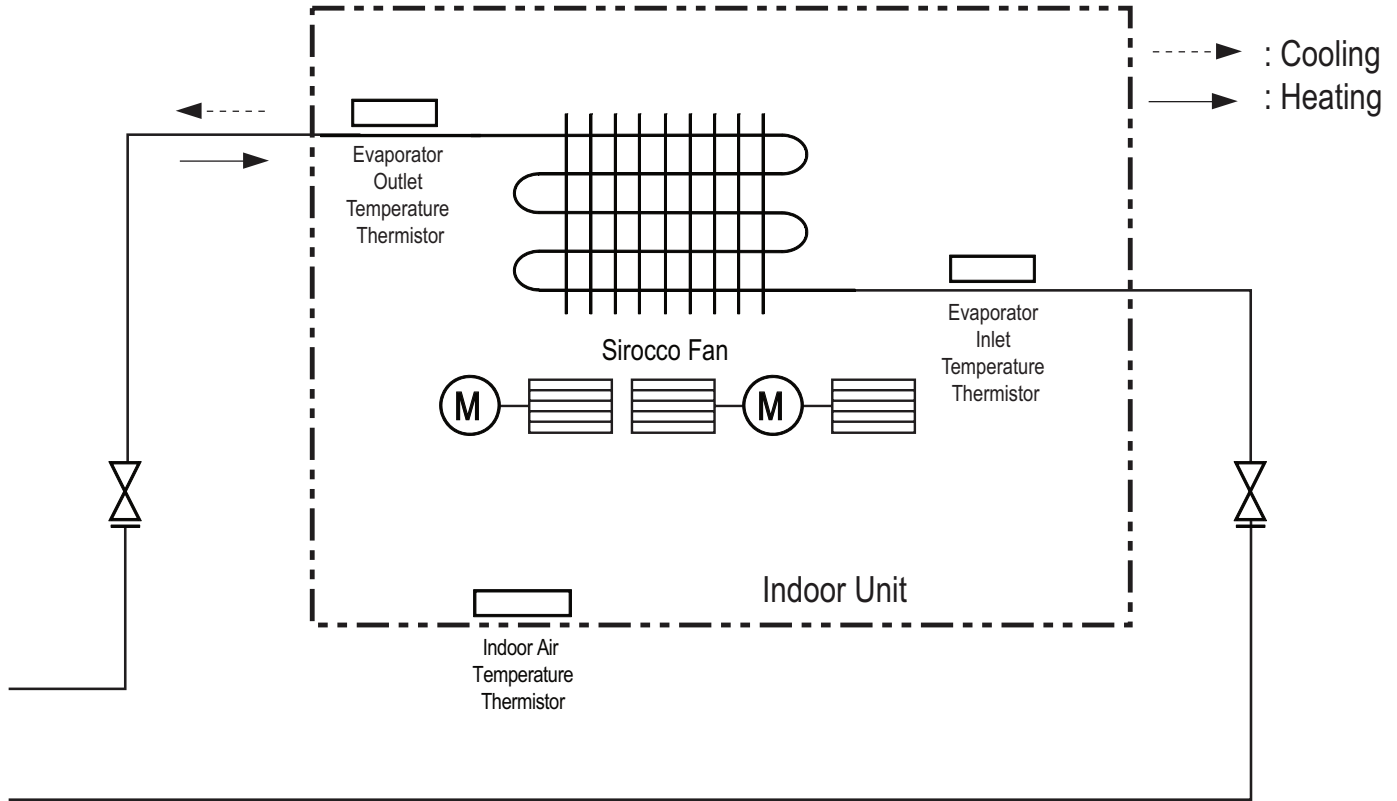
Table 47: Multi F Ceiling-Concealed Duct (Low Static) LMDN096HV Indoor Unit Refrigerant Pipe Connection Port Diameters.

Model No.	Vapor (inch)	Liquid (inch)
LMDN096HV	Ø3/8	Ø1/4

Table 48: Multi F Ceiling-Concealed Duct (Low Static) LMDN096HV Indoor Unit Thermistor Details.

Description (Based on Cooling Mode)	PCB Connector
Indoor Air Temperature Thermistor	CN-ROOM
Evaporator Inlet Temperature Thermistor	CN-PIPE/IN
Evaporator Outlet Temperature Thermistor	CN-PIPE/OUT

Figure 127:LMDN126HV and LMDN186HV Refrigerant Flow Diagram.



Ceiling-Concealed Duct (Low Static)

Table 49: Multi F Ceiling-Concealed Duct (Low Static) LMDN126HV and LMDN186HV Indoor Unit Refrigerant Pipe Connection Port Diameters.

Model No.	Vapor (inch)	Liquid (inch)
LMDN126HV	Ø3/8	Ø1/4
LMDN186HV	Ø1/2	

Table 50: Multi F Ceiling-Concealed Duct (Low Static) LMDN126HV and LMDN186HV Indoor Unit Thermistor Details.

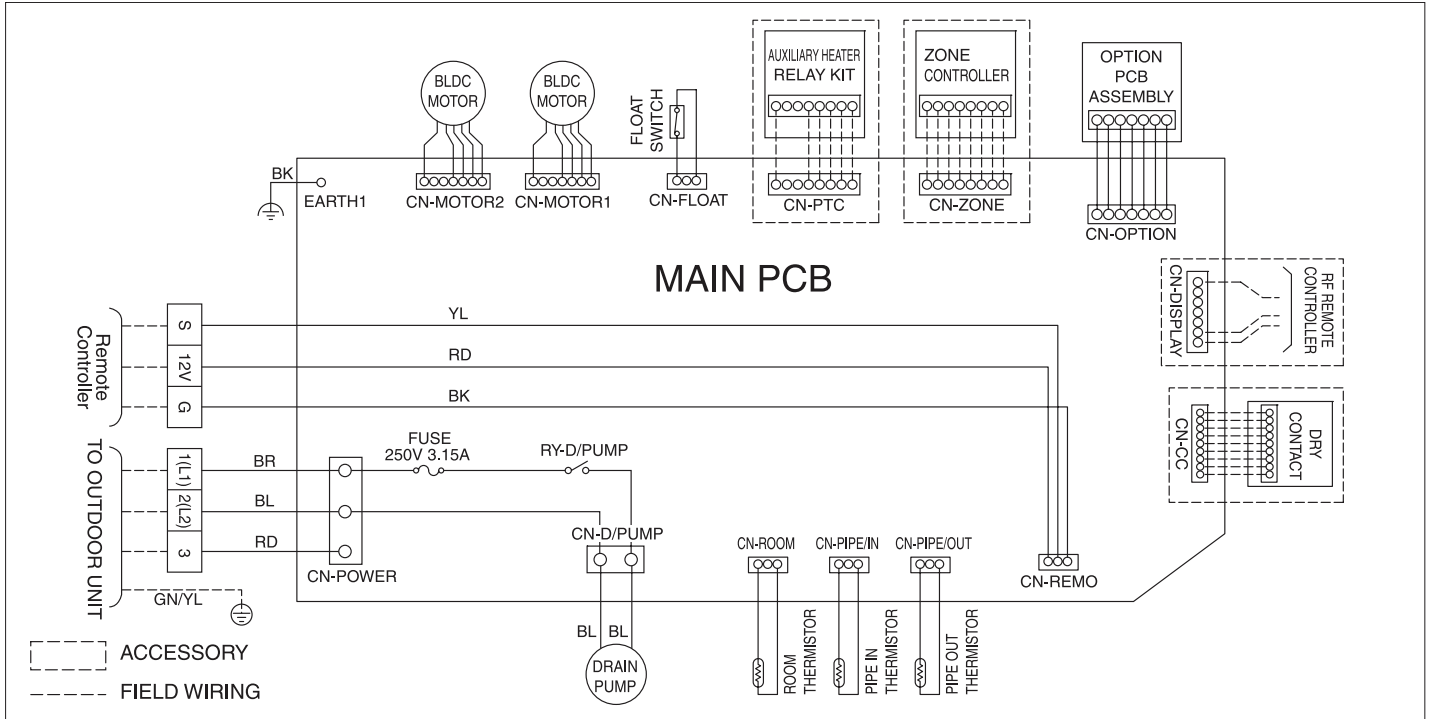
Description (Based on Cooling Mode)	PCB Connector
Indoor Air Temperature Thermistor	CN-ROOM
Evaporator Inlet Temperature Thermistor	CN-PIPE/IN
Evaporator Outlet Temperature Thermistor	CN-PIPE/OUT

DUCT (LOW STATIC) INDOOR UNITS

Wiring Diagram

MULTI F
MULTI F MAX

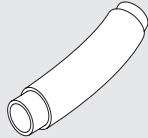


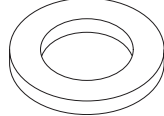
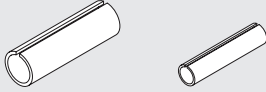

Figure 128: Multi F Ceiling-Concealed Duct (Low Static) LMDN096HV, LMDN126HV, and LMDN186HV Indoor Units Wiring Diagram.



Multi F and Multi F MAX Indoor Unit Engineering Manual

Factory Supplied Parts

Table 51: Parts Table.

Part	Quantity	Image	Part	Quantity	Image
Drain Hose	One (1)		Zip Ties	Four (4)	
Metal Clamp	Two (2)		Washers for Hanging Brackets	Eight (8)	
Insulation for Fittings	One (1) Set	 For Vapor Piping For Liquid Piping	Simple Controller with Mode Selection (AKB72955816) ¹	One (1)	

¹Simple Mode Controllers for the ceiling-concealed duct (low static) indoor units are also referenced by Model No. PQRCVCL0QW.

Factory Supplied Materials

- Owner's Manual
- Installation Manual

Required Tools

- Level
- Screwdriver
- Electric drill
- Hole core drill
- Flaring tool set
- Torque wrenches
- Hexagonal wrench
- Gas-leak detector
- Thermometer

⚠ WARNING

- Read all instructions before installing the product.
- Installation work must be performed by authorized personnel and in accordance with the national wiring standards and all local codes.

DUCT (LOW STATIC) INDOOR UNITS

Installation and Best Layout Practices

MULTI F
MULTI F MAX

Selecting the Best Location

Do's

- Place the unit where air circulation will not be blocked.
- Place the unit where drainage can be obtained easily.
- Place the unit where noise prevention is taken into consideration.
- Ensure there is sufficient strength to bear the load of the indoor unit.
- Ensure there is sufficient maintenance space.
- Locate the indoor unit in a location that is level, and where it can be easily connected to the outdoor unit / branch distribution unit.

⚠ WARNING

Don'ts

- The unit should not be installed near a heat or steam source, or where considerable amounts of oil, iron powder, or flour are used.
- The unit should not be installed where sulfuric acid and flammable or corrosive gases are generated, vented into, or stored.
- Avoid installing the unit near high-frequency generators or near any equipment that generates an electromagnetic field (minimum 3-1/3 feet away).
- Do not install the unit near a doorway.

The unit may be damaged, may malfunction, and / or will not operate as designed if installed in any of the conditions listed.

Installing in an Area Exposed to Unconditioned Air

In some installation applications, areas (floors, walls) in some rooms may be exposed to unconditioned air (room may be above or next to an unheated garage or storeroom). To countermeasure:

- Verify that carpet is or will be installed (carpet may increase the temperature by three degrees).
- Add insulation between the floor joists.
- Install radiant heat or another type of heating system to the floor.

Installing in an Area with High Humidity Levels

If the environment is prone to humidity levels of 80% or more (near the ocean, lakes, etc.) or where steam could collect in the plenum:

- Install additional insulation to the indoor unit (glass wool insulation >13/32 inches thick).
- Install additional insulation to the refrigerant piping (insulation >13/16 inches thick).
- Seal all gaps between the indoor unit and the ceiling tiles (make the area air tight) so that humidity does not transfer from the plenum to the conditioned space. Also, add a ceiling grille for ventilation.

Note:

If the unit is installed near a body of water, certain components are at risk of being corroded. Appropriate anti-corrosion methods should be taken for the unit and all components.

Figure 129: General Installation Guidelines.

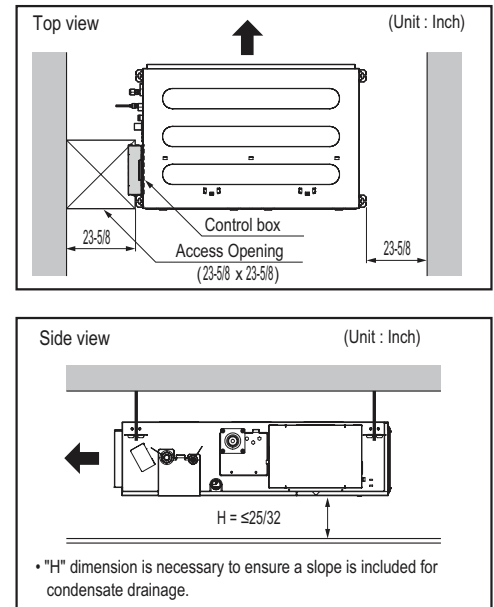


Figure 130: Service / Access Panel Dimensions.

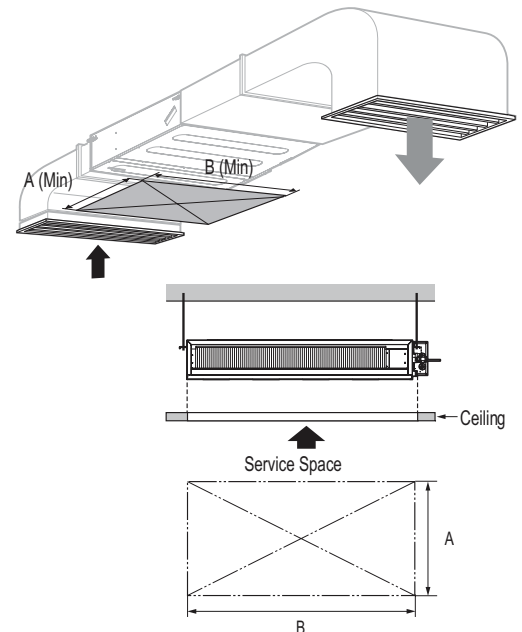


Table 52: General Access Panel Dimensions.

Model / Capacity (Btu/h)	Dimensions (in.)	
	A	B
LMDN096HV / 9,000	31-1/2	31-1/2
LMDN126HV / 12,000		39-3/8
LMDN186HV / 18,000		

Duct (Low Static) Indoor Units can be installed in two ways:

Figure 131: Air inlet from the back of the indoor unit.

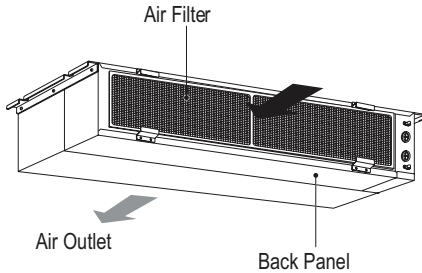


Figure 132: Air inlet from the bottom of the indoor unit.

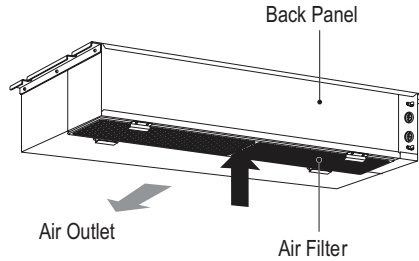


Figure 133: Indoor Unit Bolt Locations.

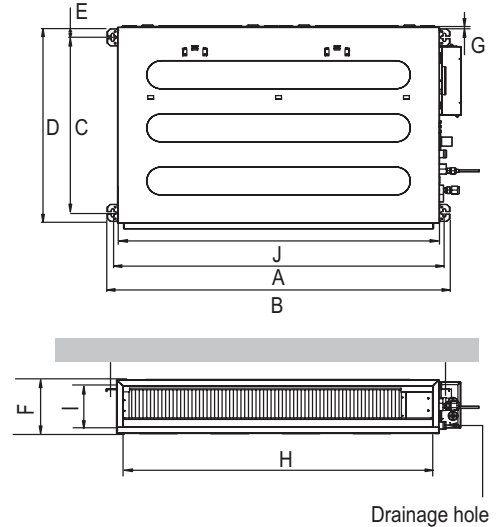


Table 53: Indoor Unit Bolt Location Dimensions.

Model / Capacity (Btu/h)	Dimensions (in.)									
	A	B	C	D	E	F	G	H	I	J
LMDN096HV / 9,000	28-27/32	30-13/32	24-23/32	27-9/16	1-13/32	7-15/32	25/32	25-31/32	6-3/32	27-9/16
LMDN126HV / 12,000	36-23/32	38-9/32						33-27/32		35-7/16
LMDN186HV / 18,000										

Preparing the Installation Area and Hanging the Indoor Unit Frame

1. Select and mark the area for the suspension or console bolts (use embedded inserts or anchor bolts in new buildings, and hole-in-anchors in older buildings).
2. Drill the holes.
3. Add the set-anchor and the plate washer to the bolts (bolts should be at least 13/32 inches in diameter), and then insert the bolts into the installation area.
4. Add the plate washer, spring washer, and nut to secure the bolts into the installation area.
5. Position the indoor unit installation plates onto the bolts. Secure using nuts, plate washers, and spring washers. Adjust for level as necessary.

Figure 134: Preparing the Installation Area.

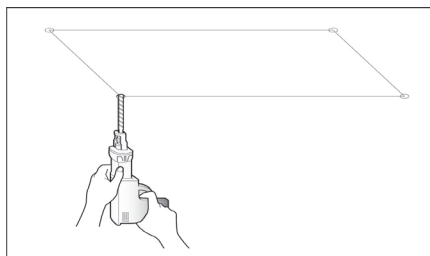


Figure 135: Console Bolt Options.

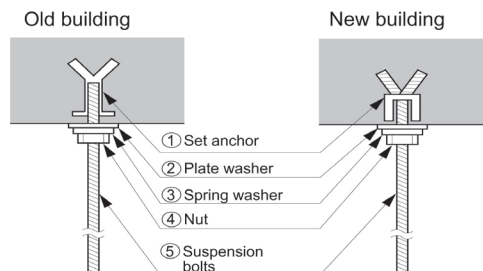
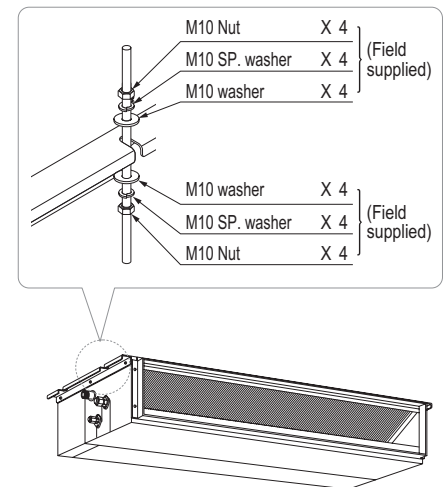


Figure 136: Hanging the Indoor Unit.



Note:

Install a canvas duct to the air outlet and air inlet so that vibration from the indoor unit does not carry to the duct or ceiling. Also, add insulation to the interior of the duct, and apply anti-vibration to the suspension bolts.

WARNING

- Unit must be installed correctly.
- Tighten the nuts and bolts to prevent the unit from falling.

DUCT (LOW STATIC) INDOOR UNITS

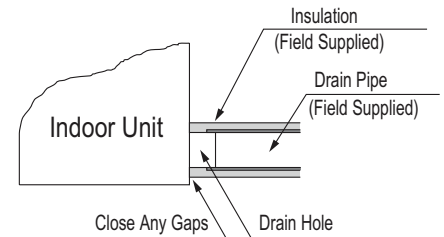
Installation and Best Layout Practices

MULTI F
MULTI F MAX

Installing the Drain System

- Drain piping must have downward gradient of at least 1/50 to 1/100; to prevent reverse flow, slope should not be straight up and down.
- Do not damage the drain port on the indoor unit when connecting the field-supplied drain piping.
- Drain piping specifications:
 - Indoor Unit Drain Connection: 1-1/4 inch outside diameter.
 - Field-Supplied Drain Piping: Polyvinyl chloride piping with 1-inch inside diameter and pipe fittings.

Figure 137: Drain Connection.

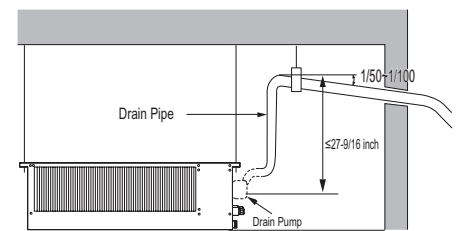


Ducted (low static) indoor units have two options for condensate drainage: Using the factory-installed drain pump, or using a gravity drain.

Using the Drain Pump

- Maximum drain lift is 27-9/16 inches, therefore, the drain piping should be placed below the maximum lift height.
- Field-installed drain piping must have downward gradient of at least 1/50 to 1/100; to prevent reverse flow, slope should not be straight up and down.

Figure 138: Indoor Unit Using Drain Pump.

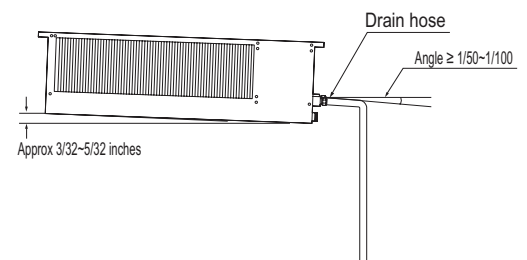


Pump location may be different on the indoor unit.

Using the Gravity Drain

Field-drain piping must have downward gradient of at least 1/50 to 1/100; to prevent reverse flow, slope should not be straight up and down.

Figure 139: Indoor Unit Using Gravity Drain.

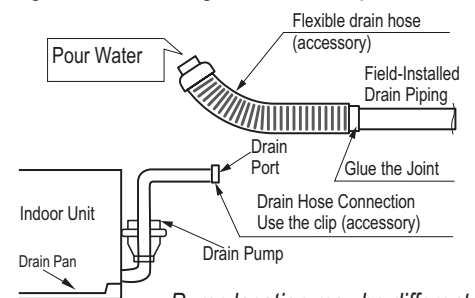


Checking the Drain Pump

The unit uses a drain pump to remove condensate. The pump must be tested before the system operates.

- Connect the flexible drain hose to the field-installed drain piping; leave it as is until the test is complete.
- Pour water into the flexible drain hose and check for leaks.
- After power wiring installation is complete, operate the drain pump to see if it sounds and functions properly.
- After the test is complete, connect the flexible drain hose to the indoor unit drain port.

Figure 140: Checking the Drain Pump.

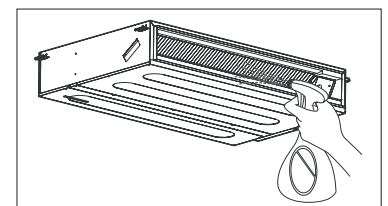
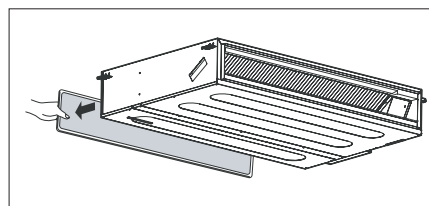


Pump location may be different on the indoor unit.

Checking the Drainage System

1. Remove the air filter.
2. Check the drainage.
 - Spray water on the evaporator.
 - Verify that water flows through the indoor unit drain hose without leaking.

Figure 141: Checking the Drainage System.



Insulating the Refrigerant and Drain Piping

Refrigerant Piping Insulation

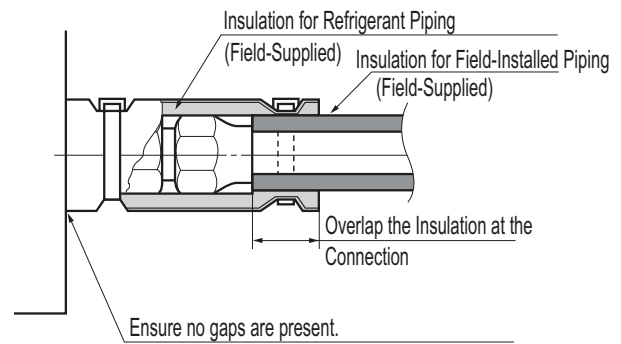
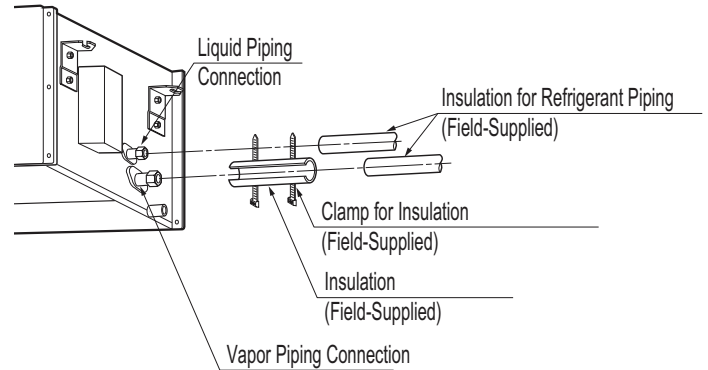
Field-installed vapor and liquid refrigerant piping lines must be properly and completely covered in insulation (up to the indoor unit piping connections). Any exposed piping may generate condensate or will cause burns if touched. Insulation for this field-installed refrigerant piping must have a minimum heat resistance of 248°F.

Duct (low static) indoor units have been tested under and meet the requirements of the "KS Conditions." If the indoor unit is installed and is operated at an extended period in a highly humid environment (dew point temperature >73°F), however, condensate will form. To prevent this phenomenon, install adiabatic glass wool insulation with a thickness of 13/32 to 13/16 inches thick. Also, install glass wool insulation on all indoor unit that are located in the ceiling plenum.

Drain Piping Insulation

Drain piping must have insulation a minimum of 7/32 inches thick.

Figure 142: Insulating the Piping.



DUCT (LOW STATIC) INDOOR UNITS

Installation and Best Layout Practices

MULTI F
MULTI F MAX

Power Wiring / Communications Cable Guidelines

- Follow manufacturer's circuit diagrams in the technical manuals.
- Confirm power source specifications.
- Confirm that the electrical capacity is sufficient.
- Starting current must be maintained ± 10 percent of the rated current marked on the outdoor unit name plate.
- Confirm cable thickness specifications.
- It is recommended that a circuit breaker is installed, especially if conditions could become wet or moist.
- Include a disconnect in the power wiring system, add an air gap contact separation of at least 1/8 inch in each active (phase) conductor.

⚠ WARNING

- Loose wiring may cause unit malfunction, or the terminal to overheat and catch fire.
- Terminal screws may become loose during transport. Properly tighten the terminal connections during installation.

A voltage drop may cause the following problems:

- Magnetic switch vibration, fuse breaks, or disturbance to the normal function of an overload protection device.
- Compressor will not receive the proper starting current.

Connecting the Power Wiring and Communications Cable

1. Insert the power wiring / communications cable from the outdoor unit or branch distribution unit (Multi F MAX systems only) through the side of the indoor unit. Pass the wiring through the designated access holes to prevent damage. To prevent electromagnetic interference and product malfunction, leave a space between the power wiring and communications cable outside of the indoor unit.
2. Connect each wire to its appropriate terminal on the indoor unit control board. Verify that the color and terminal numbers from the outdoor unit or branch distribution unit (Multi F MAX systems only) wiring match the color and terminal numbers on the indoor unit.
3. Secure the power wiring / communications cable with the cable restraint.
4. Screw the steel clamp to the inside of the control panel.
 - Place the wiring / cables in the clamp and tighten the plastic clamp to an open surface of the control panel.
 - When clamping, do not apply force to the wiring connections.
 - Neatly arrange the wiring, do not catch the wiring in the electric box cover, and ensure the cover firmly closes.
5. Fill in any gaps around the wiring access hole with sealant to prevent foreign particles from entering the indoor unit.

Using a Conduit

1. Remove the rubber stopper on the indoor unit. Pass the power wiring / communications cable through the conduit, the conduit mounting plate, and to the control panel of the indoor unit.
2. Connect the power wiring / communications cable to the indoor unit terminal block.
3. Screw the conduit mounting plate to the indoor unit.
4. Tighten the conduit and the conduit mounting plate together.

Figure 143: Indoor Unit to Outdoor Unit / Branch Distribution Unit (Multi F MAX systems only) Power Wiring / Communications Cable Connections.

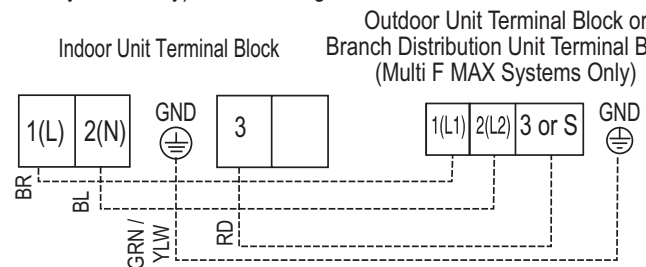
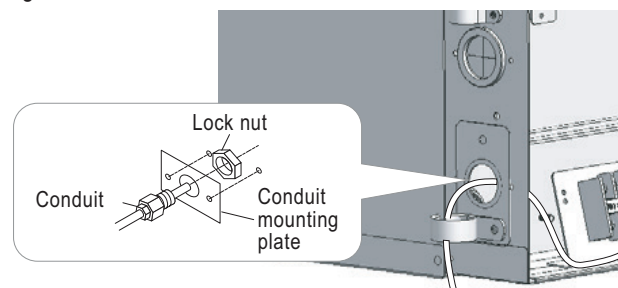


Figure 144: Exterior View of Conduit Installation.



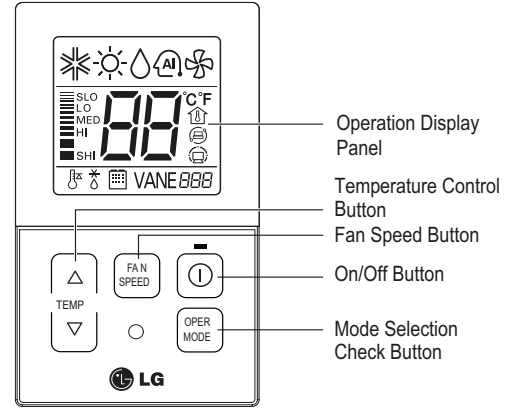
Controller Options

Ceiling-concealed duct (low static) indoor units include an LG-supplied wired controller (AKB72955816)¹, but other optional LG-supplied wired controllers are available (see Controls and Options overview on pages 9 to 12 in this manual's Introduction section). The wireless handheld controller (Model No. PQWRHQ0FDB) is also an optional accessory with use of the wired controller.

- Operation Display Panel: Displays operation conditions.
- Temperature Control Button: Sets desired temperature.
- Fan Speed Button: Sets desired fan speed.
- On / Off Button: Turns system operation on and off.
- Mode Selection Check Button: Selects the operation mode: Cooling, Heating, Auto, Dry (Dehumidification), or Fan.

Wired Controller

Figure 145:AKB72955816¹ Wired Controller.



Note:

Each function will display on the LED for about three (3) seconds when the power is first cycled on.

¹Simple Mode Controllers for the ceiling-concealed duct (low static) indoor units are also referenced by Model No. PQRCVCL0QW.

Wired Controller Connections

Controllers can connect to the indoor unit in one of two different ways.

1. LG Wired Remote Extension Cable with Molex plug (PZCWRC1; sold separately) that connects to the CN-REMO terminal on the indoor unit PCB.
2. Field-supplied controller cable that connects to the indoor unit terminal block (must be at least UL2547 or UL1007, 22 AWG, two-core, one-shield core, at least FT-6 rated if local electric and building codes require plenum cable usage).

Note:

When using field-supplied controller cable, make sure to connect the yellow to yellow (communications wire), red to red (12V power wire), and black to black (ground wire) terminals from the remote controller to the indoor unit terminal blocks.

Figure 146:PZCWRC1 LG Wired Remote Extension Cable.

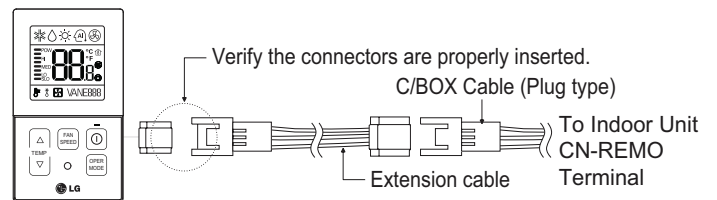
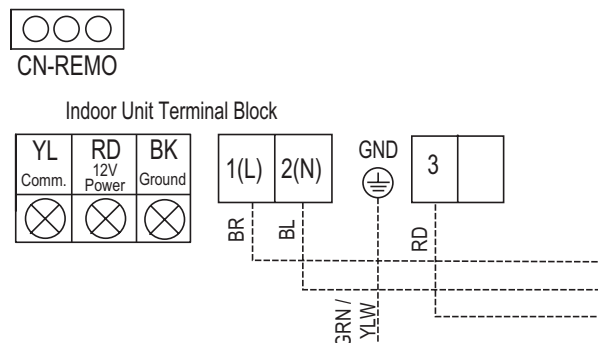


Figure 147:Wired Controller Connections on the Indoor Unit Terminal Block.



DUCT (LOW STATIC) INDOOR UNITS

Installation and Best Layout Practices

MULTI F
MULTI F MAX

Hanging the Wired Controller

1. The controller wiring / cable can be installed in one of three directions: top, back, or on the right side. If top or right side installation is desired, remove cable guide grooves on the controller, and then position wiring / cable on applicable side.
2. Choose and mark the area of installation, and then screw the wall plate into place (using the provided parts). Install the controller wall plate to fit the electrical box if one is present. Ensure that no gaps exist between the wall plate and the wall itself.
3. Arrange wiring / cables so as not to interfere with the controller circuitry. Position the wired controller on the wall plate. Snap into place by pressing the bottom part of the wired controller onto the wall plate. Make sure that no gaps exist between the wired controller and the wall plate on all sides.
4. To remove wired controller from the wall plate, insert a screwdriver into the two holes at the bottom. Twist screwdriver to release controller. Do not damage the controller components when removing.

Figure 148: Removing the Cable Guide Grooves.

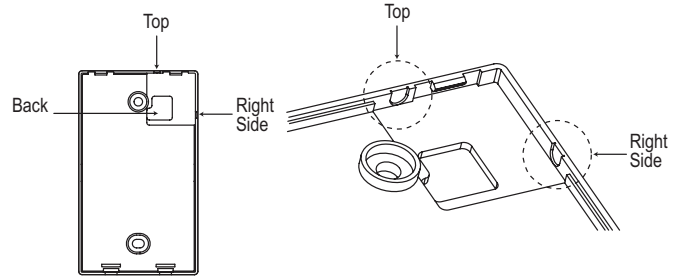


Figure 149: Attaching the Wall Plate.

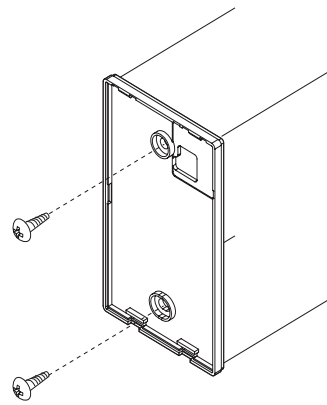
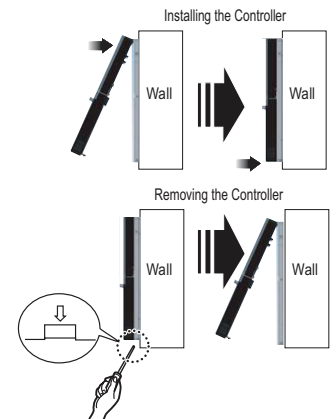


Figure 150: Installing / Removing the Controller.



Assigning the Thermistor for Temperature Detection

Each indoor unit includes a return air thermistor assigned to sense the temperature. If a wired controller is installed, there is a choice of sensing temperature with either the indoor unit return air thermistor or the thermistor in the wired controller. It is also an option to set both thermistors to sense temperature so that indoor unit bases its operation on the first thermistor to reach the designated temperature differential. For applicable indoor units, an optional Remote Temperature Sensor can be used in lieu of the return air thermistor—either alone or in conjunction with a wired controller thermistor as previously described.

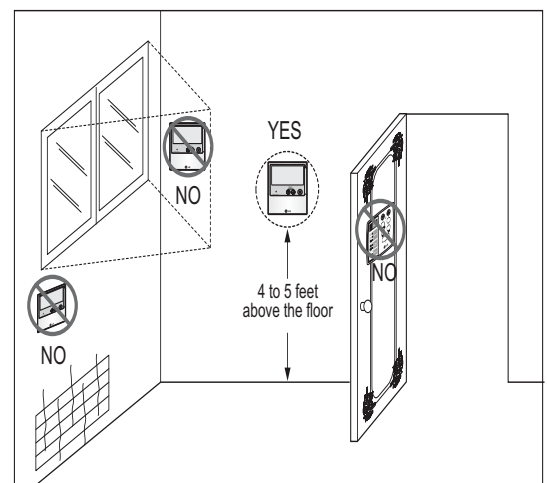
Wired Controller Placement

Wired controllers include a sensor to detect room temperature. To maintain comfort levels in the conditioned space, the wired controller must be installed in a location away from direct sunlight, high humidity, and where it could be directly exposed to cold air. Controller must be installed four (4) to five (5) feet above the floor where its LED display can be read easily, in an area with good air circulation, and where it can detect an average room temperature.

Do not install the wired controller near or in:

- Drafts or dead spots behind doors and in corners
- Hot or cold air from ducts
- Radiant heat from the sun or appliances
- Concealed pipes and chimneys
- An area where temperatures are uncontrolled, such as an outside wall

Figure 151: Proper Location for the Wired Controller.



External Static Pressure Control

To provide a required air flow rate that accounts for the external static pressure change, follow the steps below.

1. To access system installer setting mode, press and hold the temperature increase and mode selection buttons simultaneously for approximately three (3) seconds. Choose setting code value "06" by pressing the mode selection button.
2. Use the temperature increase and decrease buttons to select the desired setting value.

Setting Values

- 01 : V-H 03 : V-L
- 02 : F-H 04 : F-L

3. Press the on / off button to save the established settings.
4. To deactivate system installer setting mode after the settings have been established, press and hold the temperature increase and mode selection check buttons simultaneously for approximately three (3) seconds. If a button is not pressed for more than 25 seconds, the system installer setting mode will automatically deactivate.

Figure 152: Select Code and Set Value.

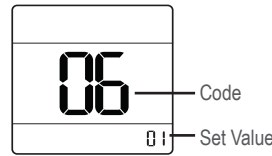


Figure 153: Controller External Static Pressure Setting Display.

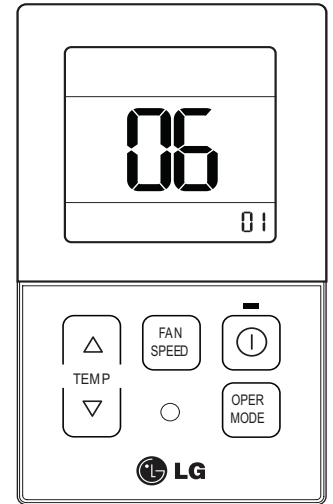


Table 54: Static Pressure Setting Table.

Pressure Selection		Function	
		Zone State	External Static Pressure Standard Value
01	V-H	Variable	High
02	F-H	Fixed	High
03	V-L	Variable	Low
04	F-L	Fixed	Low

Note:

- Select the position after verifying duct work and the external static pressure of the indoor unit.
- Factory set to pressure selection F-H.

DUCT (LOW STATIC) INDOOR UNITS

Installation and Best Layout Practices

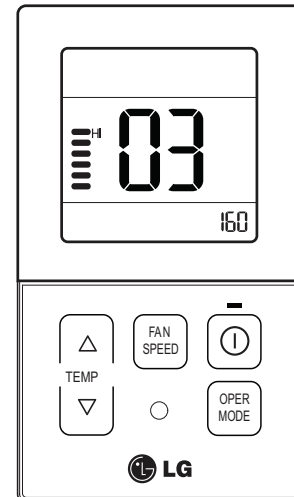
MULTI F
MULTI F MAX

Assigning Air Flow

To assign an air flow for each fan speed, follow the steps below.

1. To access system installer setting mode, press and hold the temperature increase and mode selection buttons simultaneously for approximately three (3) seconds. Choose setting code value "03" by pressing the mode selection button.
2. Use the fan speed button to select the desired fan speed. (Lo→Med→Hi will display on the LED).
3. Use the temperature increase and decrease buttons to select the desired external static pressure setting value (thereby assigning the respective airflow). External static pressure value range: 0~255; the value will display near the lower right corner of the LED.
4. Press the on / off button to save the established settings.
5. To deactivate system installer setting mode after the settings have been established, press and hold the temperature increase and mode selection check buttons simultaneously for approximately three (3) seconds. If a button is not pressed for more than 25 seconds, the system installer setting mode will automatically deactivate.

Figure 154: Controller External Static Pressure Setting Display.



Note:

- A certified technician must set the external static pressure value(s). If the external static pressure is set incorrectly, the system may malfunction.
- Do not alter the external static pressure value that corresponds to each air flow level.
- External static pressure value can vary depending on the indoor unit.
- If by pressing the fan speed button during external static pressure setup, the fan speed is raised to the next level, the air flow value of the previous fan speed will be maintained (external static pressure setting value is saved).

CEILING-CONCEALED DUCT (HIGH STATIC) INDOOR UNIT DATA

“Mechanical Specifications” on page 112

“General Data / Specifications” on page 113

“Dimensions” on page 114

“Cooling Capacity Table” on page 115

“Heating Capacity Table” on page 116

“External Static Pressure” on page 117

“Acoustic Data” on page 117

“Refrigerant Flow Diagrams” on page 118

“Wiring Diagram” on page 119

“Factory Supplied Parts and Materials” on page 120

“Installation and Best Layout Practices” on page 121

DUCT (HIGH STATIC) INDOOR UNITS

Mechanical Specifications and Features

MULTI F
MULTI F MAX

Ceiling-Concealed Duct (High Static) Indoor Unit

General

All LG indoor units are factory assembled, wired, piped, and provided with a control circuit board, fan, and motor. Ceiling-Concealed Duct (High Static) units are designed for high-speed air volume against an external static pressure up to 0.78"WG for the 24,000 Btu/h model; up to 0.55"WG for the 36,000 Btu/h model.

Coil

Indoor unit coils are factory built and are comprised of aluminum fins mechanically bonded to copper tubing. Each unit has two rows of coils, which are pressure tested at the factory. Each unit is provided with a factory installed condensate drain pan below the coil.

Refrigerant System

System is designed for use with R410A refrigerant. The refrigeration circuit is pressure-tested at the factory and shipped with a holding charge of helium gas. Refrigerant pipe connections are 45° flare, and all refrigerant lines from the outdoor unit to the indoor units must be field insulated.

Electrical

Each indoor unit is designed to operate using 208–230/60/1 power with voltage variances of ±10%.

Casing

The casing is designed to mount fully concealed above a finished ceiling. Casing is manufactured of galvanized steel plate. Cold surfaces of the unit are covered internally with a coated polystyrene insulating material, and covered externally with sheet insulation made of ethylene propylene diene monomer (M-Class) (EPDM). External insulation is plenum rated and conforms to ASTM Standard D-1418. Hanger brackets are included on the casing to support the weight on four corners. Unit has a front horizontal supply air discharge outlet, and one dedicated rear horizontal return air inlet.

Fan Assembly and Control

The units have two direct-drive, Sirocco fans made of high strength ABS GP-2200 polymeric resin that are statically and dynamically balanced. The fans are mounted on a common brushless digitally controlled (BLDC) motor with permanently lubricated and sealed ball bearings. The fan / motor assembly is mounted on vibration-attenuating rubber grommets. Fan speed is controlled using a microprocessor-based direct digital control algorithm. The indoor fan has Low, Med, High, and Auto settings for Cooling mode; and has Low,

Features

- Inverter (Variable speed fan)
- Internal drain pump
- Control lock function
- Auto operation
- Auto restart operation
- Dehumidifying function
- Two thermistor control
- External static pressure control
- Group control
- Self-diagnostics function
- Wired thermostat included

Figure 155: Ceiling-Concealed Duct (High Static) Indoor Unit.



Med, High, and Auto settings for Heating mode. Each of the settings can be field-adjusted from the factory setting (RPM / ESP). The Auto setting adjusts the fan speed based on the difference between the controller setpoint and space temperature.

Air Filter

Return air is filtered with a factory-supplied, removable, washable filter accessible from the rear of the indoor unit. High efficiency air filter options include a return filter box and an LG / Dynamic supplied air cleaner (both sold separately).

Microprocessor Control

The unit is provided with an integrated control panel to communicate with the outdoor unit. All unit operation parameters are stored in non-volatile memory resident on the unit microprocessor. The microprocessor controls space temperature through using the value provided by the temperature sensor within the indoor unit. The microprocessor control will activate indoor unit operation when the indoor room temperature falls below or rises above a setpoint temperature, at which point, a signal is sent to the outdoor unit to begin the appropriate mode. The microprocessor will also provide self-diagnostics and auto restart functions. A field-supplied four-wire power / communications cable must be installed to connect the indoor unit(s) to the outdoor unit.

Controls

The indoor unit is supplied with an LG wired controller. Communication between the indoor units and the outdoor unit is accomplished through 18 AWG, four-core, stranded and shielded power / communication cable.

Condensate Lift/Pump

The indoor unit is provided with a factory installed and wired internal condensate lift/pump capable of providing a minimum 27.5 inch lift from the bottom surface of the unit. Drain pump has a safety switch to shut off the indoor unit if the condensate rises too high in the drain pan.

Table 55: Multi F Ceiling-Concealed High-Static Ducted Indoor Unit General Data.

Model Name	LMHN240HV	LMHN360HV
Nominal Cooling Capacity (Btu/h) ¹	24,000	36,000
Nominal Heating Capacity (Btu/h) ¹	27,000	40,000
<i>Operating Range</i>		
Cooling (°F WB)	57-77	57-77
Heating (°F DB)	59-81	59-81
<i>Fan</i>		
Type	Sirocco	Sirocco
Motor Output (W) x Qty.	154 x 1	350 x 1
Motor/Drive	Brushless Digitally Controlled / Direct	Brushless Digitally Controlled / Direct
Factory Set Airflow Rate CFM (H/M/L)	688 / 618 / 530	1,130 / 953 / 706
Factory Set External Static Pressure (in. wg)	0.39	0.39
Maximum External Static Pressure (in. wg)	0.78	0.55
<i>Unit Data</i>		
Refrigerant Type ²	R410A	R410A
Refrigerant Control	EEV	EEV
Power Supply V, Ø, Hz ³	208-230, 1, 60	208-230, 1, 60
Rated Amps (A)	0.9	1.4
Sound Pressure Level (Standard Mode) ±3 dB(A) H/M/L ⁴	37 / 36 / 35	44 / 42 / 40
Dimensions (W x H x D, in.)	46-17/32 x 11-23/32 x 17-23/32	46-17/32 x 11-23/32 x 17-23/32
Net Unit Weight (lbs.)	80	91
Shipping Weight (lbs.)	91	101
Power Wiring / Communications Cable (No. x AWG) ⁵	4 x 18	4 x 18
Heat Exchanger (Row x Column x Fin / inch) x Number	(2 x 12 x 21) x 1	(3 x 12 x 21) x 1
<i>Piping</i>		
Liquid (in.)	1/4	3/8
Vapor (in.)	1/2	5/8
Drain O.D. / I.D. (in.)	1-1/4, 1	1-1/4, 1

¹Nominal capacity is rated 0 ft. above sea level with corresponding refrigerant piping length in accordance with standard length of each outdoor unit and a 0 ft. level difference between outdoor and indoor units. All capacities are net with a combination ratio between 95 – 105%.

Nominal cooling capacity rating obtained with air entering the indoor unit at 80°F dry bulb (DB) and 67°F wet bulb (WB) and outdoor ambient conditions of 95°F dry bulb (DB) and 75°F wet bulb (WB).
Nominal heating capacity rating obtained with air entering the indoor unit at 70°F dry bulb (DB) and 60°F wet bulb (WB) and outdoor ambient conditions of 47°F dry bulb (DB) and 43°F wet bulb (WB).

²This unit comes with a dry helium charge.

³Acceptable operating voltage: 187V-253V.

⁴Sound pressure levels are tested in an anechoic chamber under ISO Standard 3745 and are the same in both cooling and heating mode. These values can increase due to ambient conditions during operation.

⁵All power wiring / communications cables to be minimum 18 AWG, 4-conductor, stranded, shielded, and must comply with applicable local and national codes.

DUCT (HIGH STATIC) INDOOR UNITS

Dimensions

MULTI F
MULTI F MAX

Figure 156: LMHN240HV and LMHN360HV Dimensions.

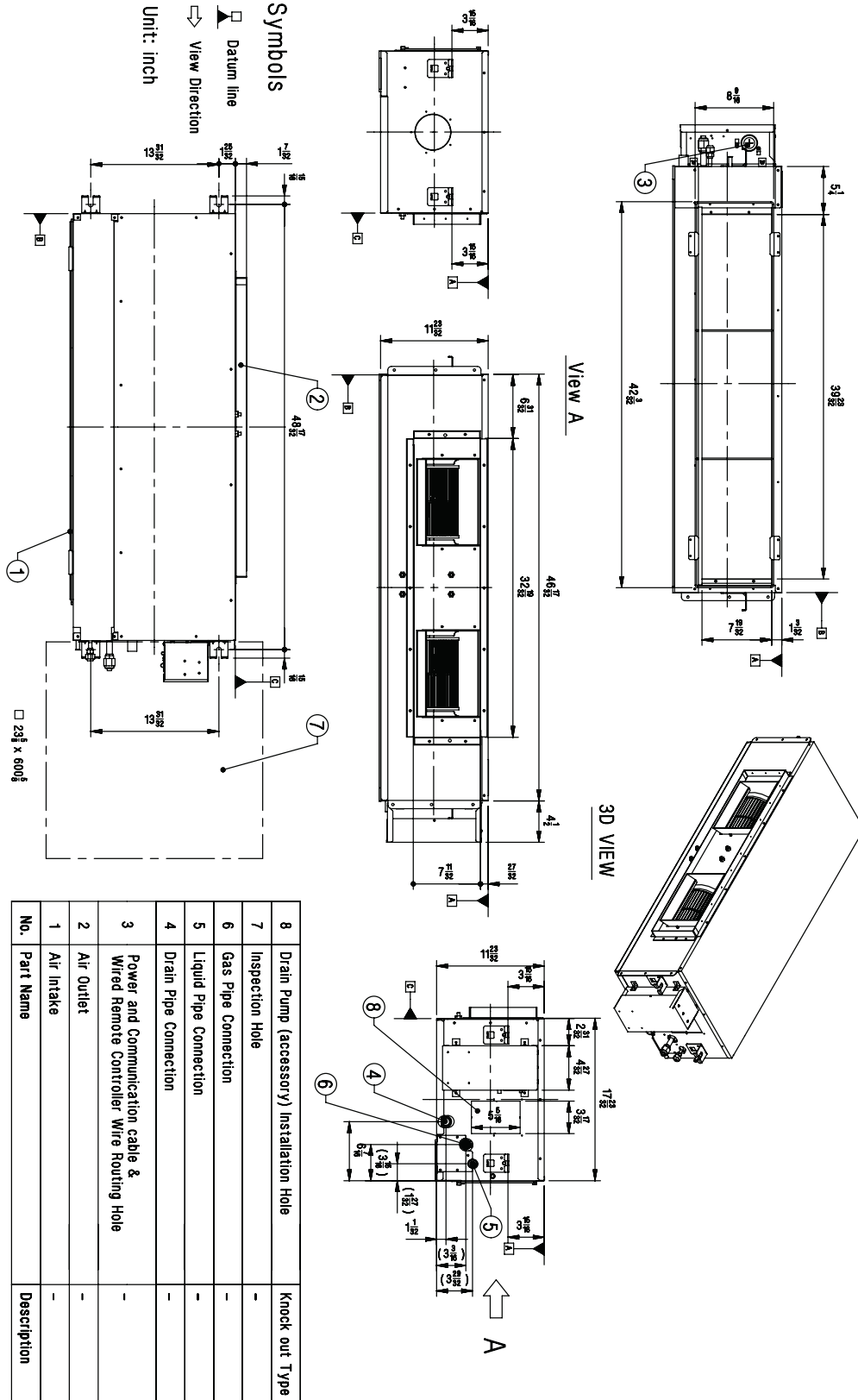


Table 56: Multi F Ceiling-Concealed Duct (High Static) Indoor Units Cooling Capacity Table.

Model No. / Nominal Capacity of Indoor Unit (Btu/h)	Outdoor Air Temp. (°F DB)	Indoor Air Temp. °F DB / °F WB											
		68 / 57		73 / 61		77 / 64		80 / 67		86 / 72		90 / 75	
		TC	SHC	TC	SHC	TC	SHC	TC	SHC	TC	SHC	TC	SHC
LMHN240HV 24,000	14	23.53	17.66	24.99	18.66	26.45	18.07	27.50	18.45	29.37	18.60	30.83	18.95
	20	23.51	17.80	24.97	18.80	26.43	18.21	27.48	18.59	29.35	18.75	30.81	19.10
	25	23.49	17.94	24.95	18.95	26.41	18.35	27.46	18.73	29.33	18.89	30.79	19.25
	30	23.47	18.08	24.93	19.09	26.39	18.49	27.44	18.88	29.30	19.04	30.76	19.40
	35	23.46	18.21	24.91	19.24	26.37	18.63	27.42	19.02	29.28	19.18	30.74	19.54
	40	23.44	18.35	24.89	19.38	26.35	18.77	27.40	19.16	29.26	19.33	30.72	19.69
	45	23.42	18.49	24.87	19.53	26.33	18.91	27.38	19.31	29.24	19.47	30.69	19.84
	50	23.40	18.62	24.85	19.67	26.31	19.05	27.36	19.45	29.21	19.61	30.67	19.99
	55	23.38	18.76	24.84	19.82	26.29	19.19	27.34	19.59	29.19	19.76	30.64	20.13
	60	23.37	18.90	24.82	19.96	26.27	19.33	27.32	19.73	29.17	19.90	30.62	20.28
	65	23.35	19.03	24.80	20.10	26.25	19.47	27.29	19.88	29.15	20.04	30.60	20.42
	70	23.33	19.17	24.78	20.25	26.23	19.61	27.27	20.02	29.13	20.19	30.57	20.57
	75	22.77	18.85	24.21	19.94	25.66	19.33	26.70	19.75	28.55	19.94	29.99	20.34
	80	22.21	18.53	23.65	19.63	25.09	19.05	26.13	19.48	27.97	19.69	29.42	20.10
	85	21.65	18.19	23.09	19.30	24.53	18.75	25.57	19.19	27.40	19.43	28.84	19.84
	90	21.09	17.85	22.53	18.96	23.96	18.45	25.00	18.90	26.83	19.15	28.27	19.59
	95	20.49	17.66	21.92	18.79	23.35	18.31	24.00	18.48	26.20	19.05	27.63	19.50
	100	19.99	17.19	21.42	18.31	22.85	17.87	23.69	18.19	25.70	18.64	27.13	19.10
105	19.49	16.71	20.92	17.84	22.35	17.43	23.38	17.91	25.20	18.23	26.63	18.70	
110	18.99	16.14	20.42	17.26	21.85	16.90	22.88	17.37	24.70	17.71	26.13	18.19	
115	18.49	15.66	19.92	16.78	21.35	16.45	22.38	16.93	24.20	17.29	25.63	17.77	
118	18.19	15.55	19.62	16.68	21.05	16.36	22.08	16.86	23.90	17.23	25.33	17.72	
122	18.10	15.51	19.52	16.64	20.95	16.34	21.98	16.83	23.81	17.21	25.23	17.71	
LMHN360HV 36,000	14	35.29	25.46	37.48	26.90	39.67	26.04	41.26	26.59	44.06	26.81	46.25	27.32
	20	35.26	25.66	37.45	27.11	39.64	26.25	41.23	26.80	44.02	27.02	46.21	27.54
	25	35.24	25.86	37.43	27.32	39.61	26.45	41.19	27.01	43.99	27.23	46.18	27.75
	30	35.21	26.06	37.40	27.53	39.58	26.65	41.16	27.21	43.96	27.44	46.14	27.96
	35	35.18	26.25	37.37	27.73	39.55	26.85	41.13	27.42	43.92	27.65	46.11	28.17
	40	35.16	26.45	37.34	27.94	39.52	27.06	41.10	27.63	43.89	27.86	46.07	28.39
	45	35.13	26.65	37.31	28.15	39.49	27.26	41.07	27.83	43.86	28.07	46.04	28.60
	50	35.10	26.85	37.28	28.36	39.46	27.46	41.04	28.04	43.82	28.27	46.00	28.81
	55	35.08	27.04	37.25	28.57	39.43	27.66	41.01	28.24	43.79	28.48	45.97	29.02
	60	35.05	27.24	37.23	28.78	39.40	27.86	40.97	28.45	43.76	28.69	45.93	29.23
	65	35.02	27.44	37.20	28.98	39.37	28.06	40.94	28.65	43.72	28.90	45.90	29.44
	70	34.99	27.63	37.17	29.19	39.34	28.26	40.91	28.86	43.69	29.10	45.86	29.65
	75	34.15	27.18	36.32	28.75	38.49	27.87	40.05	28.47	42.82	28.75	44.99	29.32
	80	33.31	26.71	35.47	28.29	37.64	27.46	39.20	28.08	41.96	28.39	44.12	28.97
	85	32.48	26.23	34.63	27.82	36.79	27.03	38.35	27.66	41.10	28.00	43.26	28.61
	90	31.64	25.73	33.79	27.33	35.94	26.59	37.50	27.24	40.25	27.61	42.40	28.23
	95	30.74	25.46	32.88	27.09	35.02	26.39	36.00	26.64	39.30	27.46	41.44	28.11
	100	29.99	24.78	32.13	26.40	34.27	25.76	35.53	26.23	38.55	26.87	40.69	27.53
105	29.24	24.10	31.38	25.72	33.52	25.13	35.07	25.82	37.80	26.28	39.94	26.96	
110	28.49	23.27	30.63	24.89	32.77	24.36	34.32	25.04	37.05	25.54	39.20	26.22	
115	27.74	22.58	29.88	24.19	32.02	23.71	33.57	24.41	36.31	24.93	38.45	25.62	
118	27.29	22.41	29.43	24.04	31.57	23.59	33.12	24.30	35.86	24.84	38.00	25.55	
122	27.14	22.36	29.28	23.99	31.43	23.55	32.97	24.26	35.71	24.81	37.85	25.53	

Ceiling-Concealed Duct (High Static)

TC = Total Capacity (kBtu/h).

SHC: Sensible Heat Capacity (kBtu/h).

Nominal capacity as rated 0 ft. above sea level and a 0 ft. level difference between outdoor and indoor units. Corresponding refrigerant piping length is accordance with standard length of each outdoor unit.

Nominal cooling capacity rating obtained with air entering the indoor unit at 80°F dry bulb (DB) and 67°F wet bulb (WB), and outdoor ambient conditions of 95°F dry bulb (DB) and 75°F wet bulb (WB).

The shaded table columns and rows indicate reference data. When operating at this temperature, these values can be different if the system is not running consistently.

DUCT (HIGH STATIC) INDOOR UNITS

Heating Capacity Table

MULTI F
MULTI F MAX

Table 57: Multi F Ceiling-Concealed Duct (High Static) Indoor Units Heating Capacity Table.

Model No. / Nominal Capacity of Indoor Unit (Btu/h)	Outdoor Air Temp.		Indoor Air Temp. °F DB					
	°F DB	°F WB	61	64	68	70	72	75
			TC	TC	TC	TC	TC	TC
LMHN240HV 24,000	0	-0.4	13.89	13.70	13.57	13.50	13.30	12.72
	5	4.5	15.65	15.46	15.33	15.26	15.07	14.48
	10	9	17.41	17.22	17.09	17.02	16.83	16.24
	17	15	19.76	19.57	19.43	19.37	19.17	18.55
	20	19	20.64	20.45	20.32	20.25	20.05	19.37
	25	23	22.11	21.91	21.78	21.72	21.52	20.74
	30	28	23.38	23.18	23.05	22.99	22.79	22.11
	35	32	24.65	24.46	24.33	24.26	24.07	23.48
	40	36	25.79	25.60	25.47	25.40	25.21	24.62
	45	41	26.93	26.74	26.61	26.54	26.35	25.76
	47	43	27.39	27.20	27.07	27.00	26.80	26.22
	50	46	27.83	27.64	27.51	27.44	27.24	26.58
	55	51	28.57	28.37	28.24	28.17	27.98	27.20
	60	56	28.57	28.37	28.24	28.17	27.98	27.32
	63	59	28.57	28.37	28.24	28.17	27.98	27.39
68	64	28.57	28.37	28.24	28.17	27.98	27.51	
LMHN360HV 36,000	0	-0.4	20.58	20.29	20.10	20.00	19.71	18.84
	5	4.5	23.19	22.90	22.71	22.61	22.32	21.45
	10	9	25.80	25.51	25.31	25.22	24.93	24.06
	17	15	29.28	28.99	28.79	28.70	28.41	27.48
	20	19	30.58	30.29	30.10	30.00	29.71	28.70
	25	23	32.75	32.46	32.27	32.17	31.88	30.72
	30	28	34.64	34.35	34.15	34.06	33.77	32.75
	35	32	36.52	36.23	36.04	35.94	35.65	34.78
	40	36	38.21	37.92	37.73	37.63	37.34	36.47
	45	41	39.90	39.61	39.42	39.32	39.03	38.16
	47	43	40.58	40.29	40.10	40.00	39.71	38.84
	50	46	41.23	40.94	40.75	40.65	40.36	39.38
	55	51	42.32	42.03	41.84	41.74	41.45	40.29
	60	56	42.32	42.03	41.84	41.74	41.45	40.47
	63	59	42.32	42.03	41.84	41.74	41.45	40.58
68	64	42.32	42.03	41.84	41.74	41.45	40.76	

TC = Total Capacity (kBtu/h).

Nominal capacity as rated 0 ft. above sea level and a 0 ft. level difference between outdoor and indoor units. Corresponding refrigerant piping length is accordance with standard length of each outdoor unit.

Nominal heating capacity rating obtained with air entering the indoor unit at 70°F dry bulb (DB) and 60°F wet bulb (WB), and outdoor ambient conditions of 47°F dry bulb (DB) and 43°F wet bulb (WB).

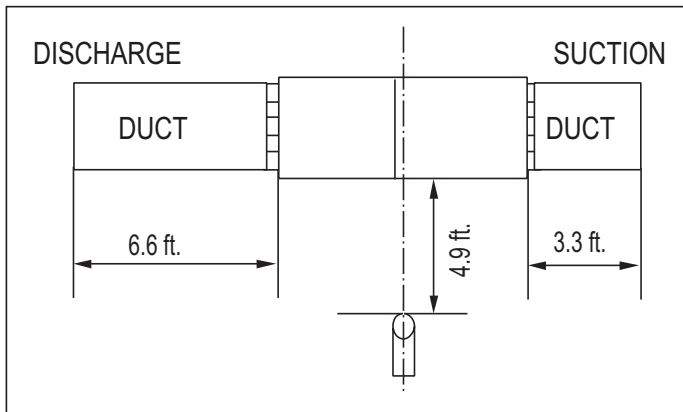
Table 58: Multi F Ceiling-Concealed Duct (High Static) External Static Pressure Setting Values Table.

Static Pressure (in. wg)			0.1	0.16	0.23	0.31	0.39	0.47	0.55	0.62	0.70	0.78
Model No. / Nominal Capacity of Indoor Unit (Btu/h)	Airflow Rate / CFM		Setting Value (in. wg)									
	LMHN240HV 24,000	High	688	82	92	103	113	122	131	140	147	154
Mid		618	78	89	99	110	119	128	137	144	151	157
Low		530	73	86	96	107	116	125	134	141	148	154
LMHN360HV 36,000	High	1,130	-	124	133	140	148	154	160	-	-	-
	Mid	953	-	112	122	130	137	145	152	-	-	-
	Low	706	-	97	107	117	125	133	141	-	-	-

Note:

- To get the desired air flow and external static pressure combination, use the setting value from the table. Using a setting value other than that listed in the table will not provide the desired combination.
- Table data is based at 230V. Air flow rate varies according to voltage fluctuation.

Figure 157: Sound Pressure Level Measurement Location.

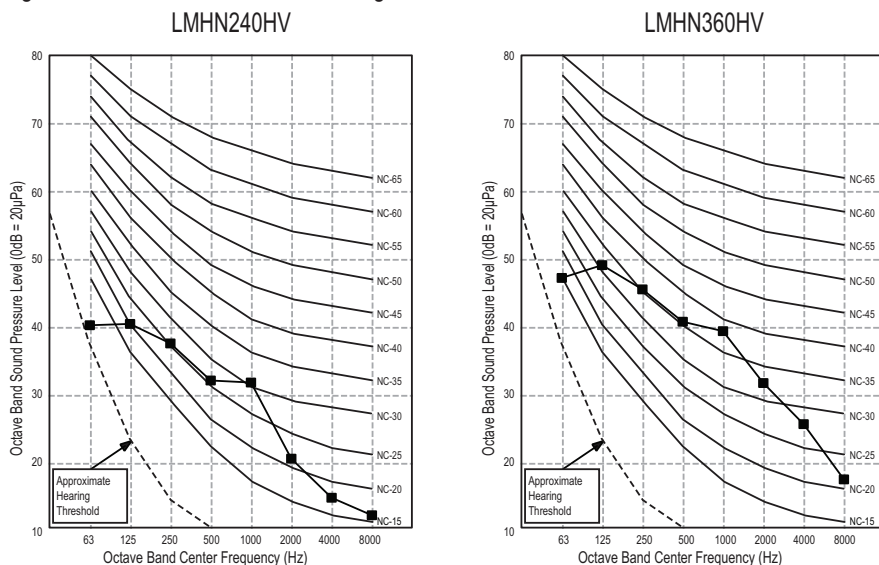


- Measurements taken with no attenuation and units operating at full load normal operating condition.
- Sound level will vary depending on a range of factors such as construction (acoustic absorption coefficient) of particular area in which the equipment is installed.
- Sound power levels are measured in dB(A)±3.
- Tested in anechoic chamber per ISO Standard 3745.

Table 59: Sound Pressure Levels (dB[A]).

Model No.	Sound Pressure Levels (dB[A]) (Cooling and Heating)		
	High Fan Speed	Medium Fan Speed	Low Fan Speed
LMHN240HV	37	36	35
LMHN360HV	44	42	40

Figure 158: Sound Pressure Level Diagrams.



DUCT (HIGH STATIC) INDOOR UNITS

Refrigerant Flow Diagrams

MULTI F
MULTI F MAX

Figure 159: LMHN240HV and LMHN360HV Refrigerant Flow Diagram.

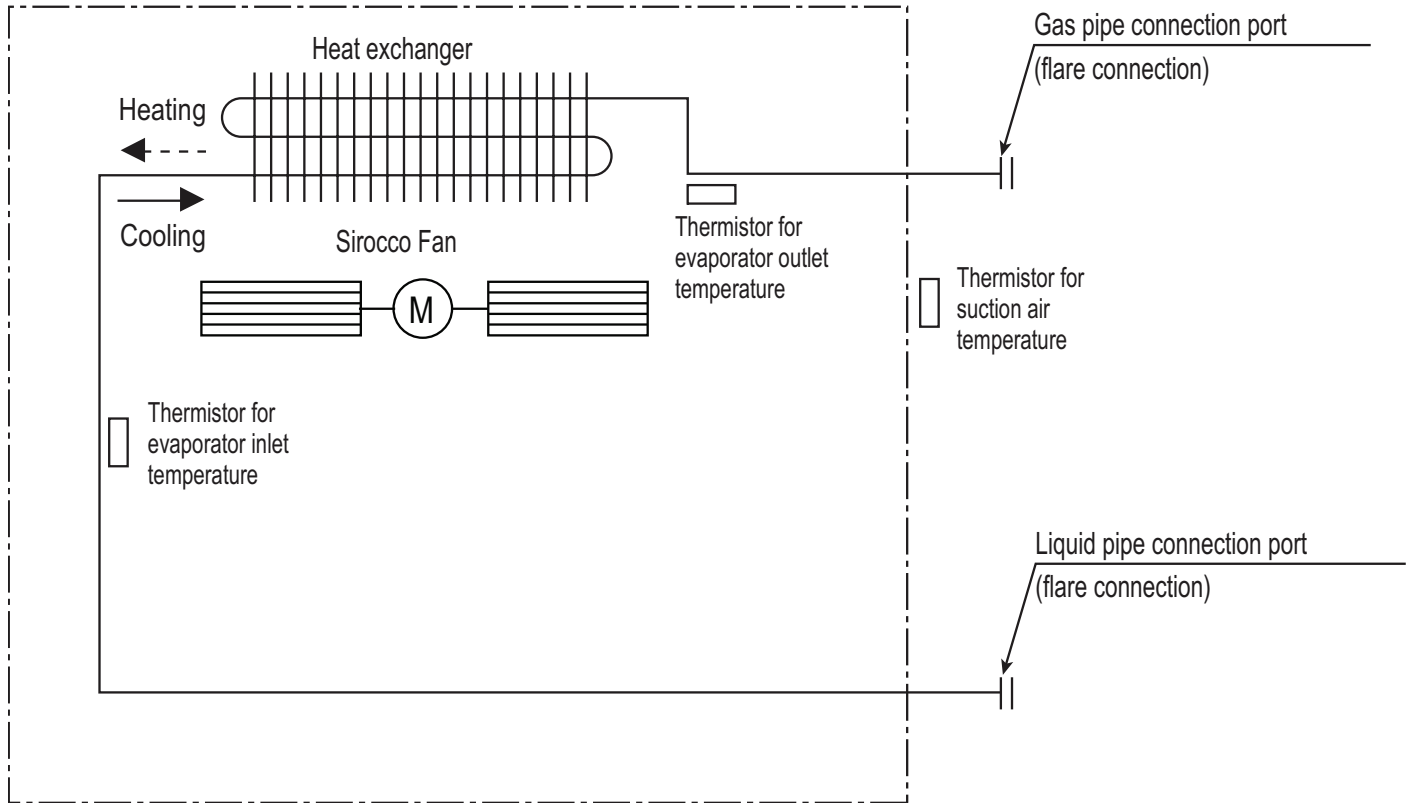


Table 60: Multi F Ceiling-Concealed Duct (High Static) Indoor Unit Refrigerant Pipe Connection Port Diameters.

Model No.	Vapor (inch)	Liquid (inch)
LMHN240HV	Ø1/2	Ø1/4
LMHN360HV	Ø5/8	Ø3/8

Table 61: Multi F Ceiling-Concealed Duct (High Static) Indoor Unit Thermistor Details.

Description (Based on Cooling Mode)	PCB Connector
Indoor Air Temperature Thermistor	CN-ROOM
Evaporator Inlet Temperature Thermistor	CN-PIPE/IN
Evaporator Outlet Temperature Thermistor	CN-PIPE/OUT

Figure 160: Multi F Ceiling-Concealed Duct (High Static) LMHN240HV Indoor Units Wiring Diagram.

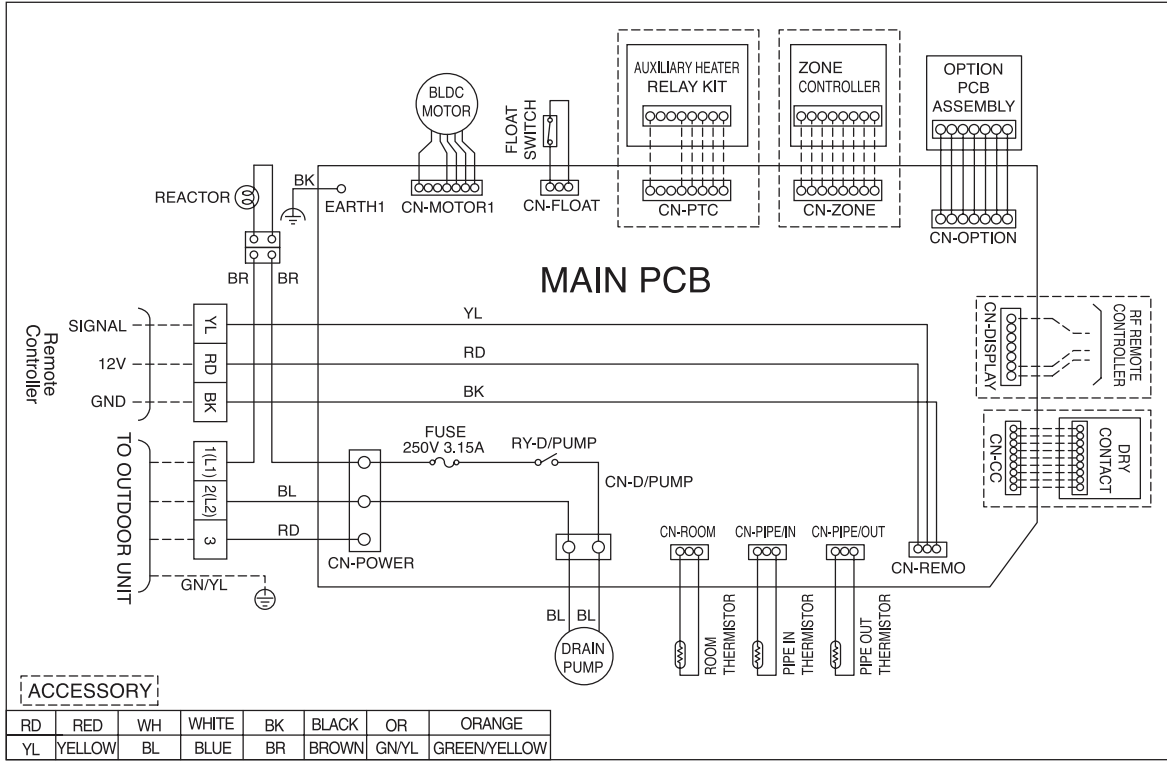
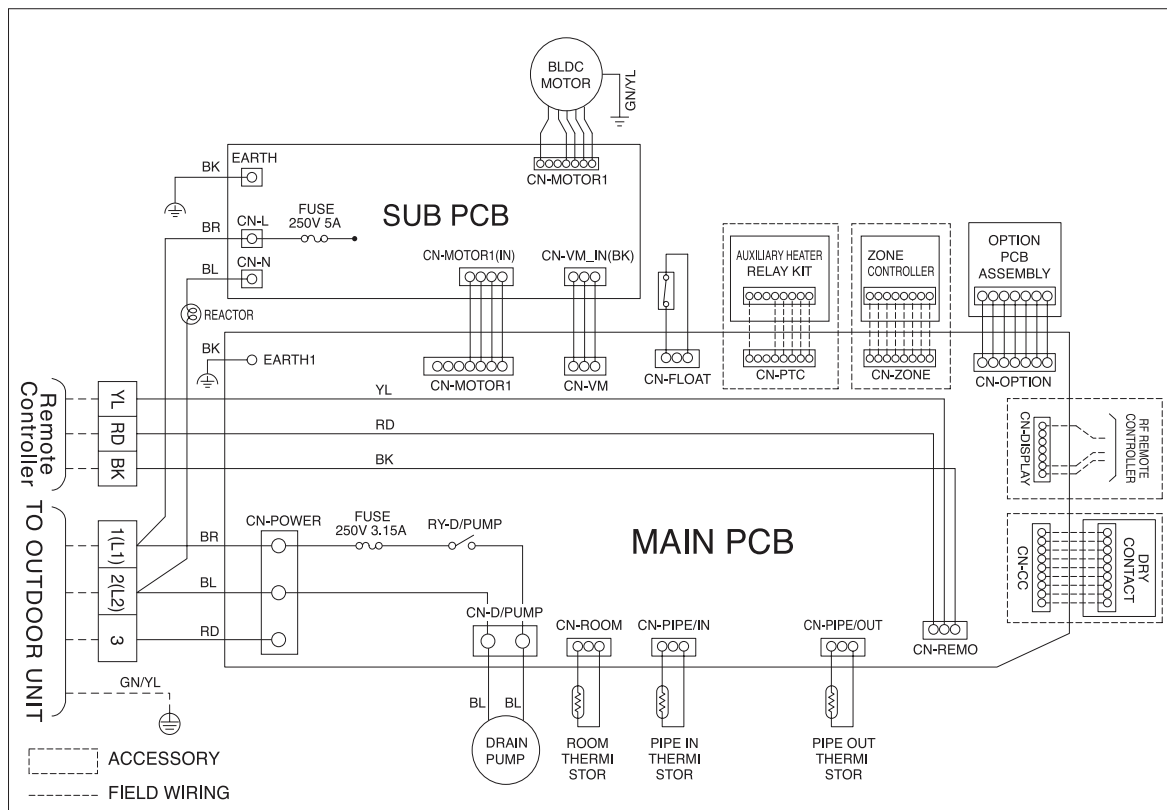


Figure 161: Multi F Ceiling-Concealed Duct (High Static) LMHN360HV Indoor Units Wiring Diagram.



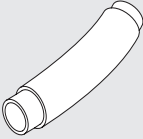
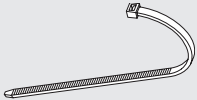

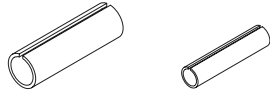
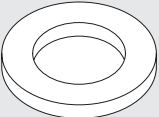

DUCT (HIGH STATIC) INDOOR UNITS

Factory Supplied Parts and Materials / Installation

MULTI F
MULTI F MAX

Factory Supplied Parts

Table 62: Parts Table.

Part	Quantity	Image	Part	Quantity	Image
Drain Hose	One (1)		Zip Ties	Four (4)	
Metal Clamp	Two (2)		Insulation for Fittings	One (1) Set	 For Vapor Piping For Liquid Piping
Washers for Hanging Brackets	Eight (8)		Simple Controller with Mode Selection (AKB72955816) ¹	One (1)	

¹Simple Mode Controllers for the ceiling-concealed duct (high static) indoor units are also referenced by Model No. PQRVCVCL0QW.

Factory Supplied Materials

- Owner's Manual
- Installation Manual

Required Tools

- Level
- Screwdriver
- Electric drill
- Hole core drill
- Flaring tool set
- Torque wrenches
- Hexagonal wrench
- Gas-leak detector
- Thermometer

⚠ WARNING

- Read all instructions before installing the product.
- Installation work must be performed by authorized personnel and in accordance with the national wiring standards and all local codes.

Selecting the Best Location

Do's

- Place the unit where air circulation will not be blocked.
- Place the unit where drainage can be obtained easily.
- Place the unit where noise prevention is taken into consideration.
- Ensure there is sufficient strength to bear the load of the indoor unit.
- Ensure there is sufficient maintenance space.
- Locate the indoor unit in a location that is level, and where it can be easily connected to the outdoor unit / branch distribution unit.

⚠ WARNING

Don'ts

- The unit should not be installed near a heat or steam source, or where considerable amounts of oil, iron powder, or flour are used.
- The unit should not be installed where sulfuric acid and flammable or corrosive gases are generated, vented into, or stored.
- Avoid installing the unit near high-frequency generators or near any equipment that generates an electromagnetic field (minimum 3-1/3 feet away).
- Do not install the unit near a doorway.

The unit may be damaged, may malfunction, and / or will not operate as designed if installed in any of the conditions listed.

Note:

If the unit is installed near a body of water, certain components are at risk of being corroded. Appropriate anti-corrosion methods should be taken for the unit and all components.

Installing in an Area Exposed to Unconditioned Air

In some installation applications, areas (floors, walls) in some rooms may be exposed to unconditioned air (room may be above or next to an unheated garage or storeroom). To countermeasure:

- Verify that carpet is or will be installed (carpet may increase the temperature by three degrees).
- Add insulation between the floor joists.
- Install radiant heat or another type of heating system to the floor.

Installing in an Area with High Humidity Levels

If the environment is prone to humidity levels of 80% or more (near the ocean, lakes, etc.) or where steam could collect in the plenum:

- Install additional insulation to the indoor unit (glass wool insulation >13/32 inches thick).
- Install additional insulation to the refrigerant piping (insulation >13/16 inches thick).
- Seal all gaps between the indoor unit and the ceiling tiles (make the area air tight) so that humidity does not transfer from the plenum to the conditioned space. Also, add a ceiling grille for ventilation.

Figure 162: Access Panel and General Service Space Required Dimensions.

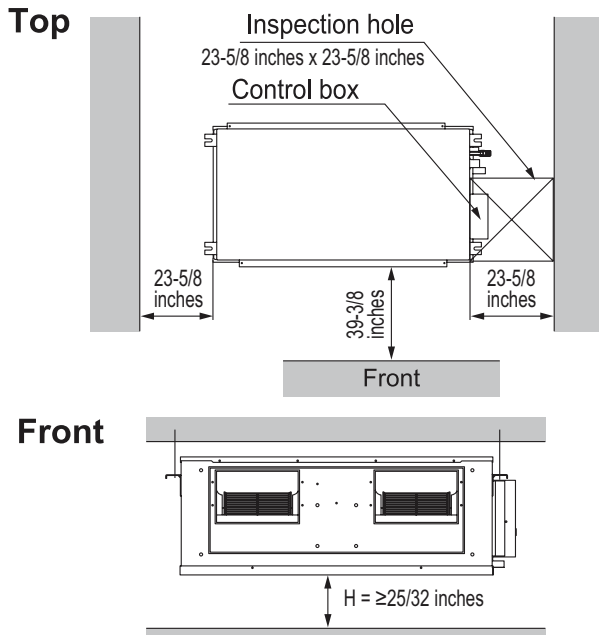


Figure 163: Indoor Unit Bolt Locations.

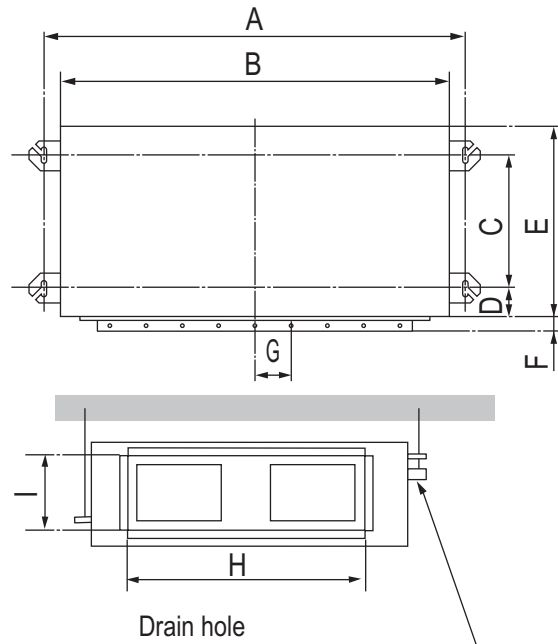


Table 63: Indoor Unit Bolt Location Dimensions.

Model / Capacity (Btu/h)	Dimensions (inches)								
	A	B	C	D	E	F	G	H	I
LMHN240HV / 24,000	48-17/32	46-17/32	13-31/32	1-25/32	17-23/32	1-7/32	3-5/8	32-19/32	7-11/32
LMHN360HV / 36,000									

DUCT (HIGH STATIC) INDOOR UNITS

Installation and Best Layout Practices

MULTI F
MULTI F MAX

Preparing the Installation Area and Hanging the Indoor Unit Frame

1. Select and mark the area for the suspension or console bolts (use embedded inserts or anchor bolts in new buildings, and hole-in-anchors in older buildings).
2. Drill the holes.
3. Add the set-anchor and the plate washer to the bolts (bolts should be at least 13/32 inches in diameter), and then insert the bolts into the installation area.
4. Add the plate washer, spring washer, and nut to secure the bolts into the installation area.
5. Position the indoor unit installation plates onto the bolts. Secure using nuts, plate washers, and spring washers. Adjust for level as necessary.

Figure 164: Preparing the Installation Area.

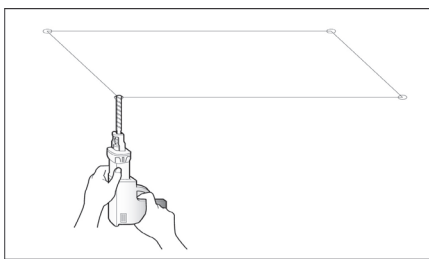


Figure 165: Suspension Bolt Options.

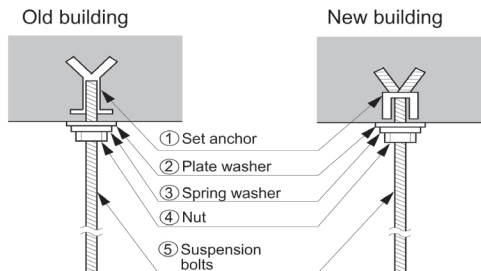
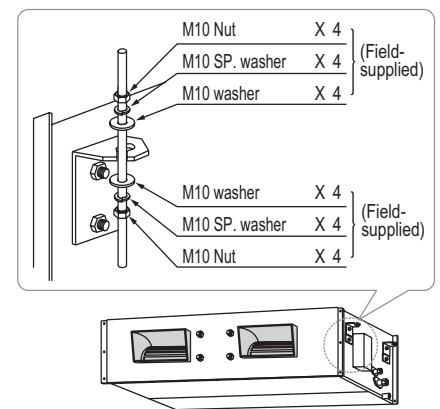


Figure 166: Hanging the Indoor Unit.



Note:

Install a canvas duct to the air outlet and air inlet so that vibration from the indoor unit does not carry to the duct or ceiling. Also, add insulation to the interior of the duct, and apply anti-vibration to the suspension bolts.

WARNING

- Unit must be installed correctly.
- Tighten the nuts and bolts to prevent the unit from falling.

Installing the Drain System

- Drain piping must have downward gradient of at least 1/50 to 1/100; to prevent reverse flow, slope should not be straight up and down.
- Do not damage the drain port on the indoor unit when connecting the field-supplied drain piping.
- Drain piping specifications:
 - Indoor Unit Drain Connection: 1-1/4 inch outside diameter.
 - Field-Supplied Drain Piping: Polyvinyl chloride piping with 1-inch inside diameter and pipe fittings.

Figure 167: Indoor Unit Drain Piping.

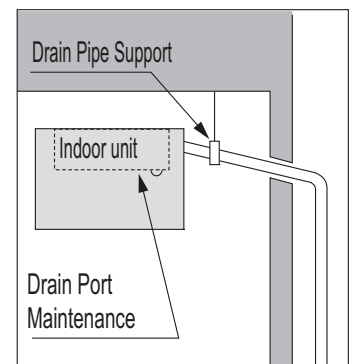
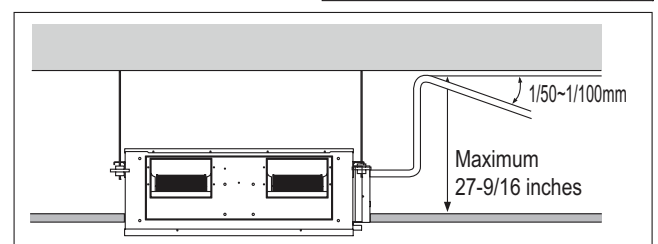
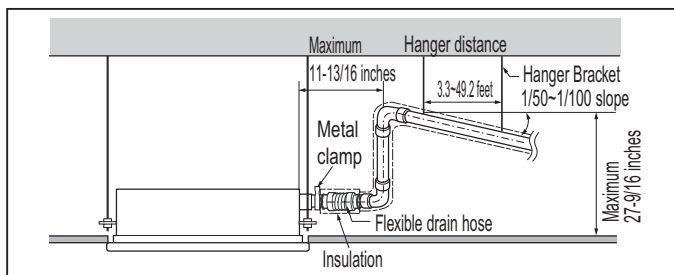


Figure 168: Drain Piping Installation Dimensions.



Note:

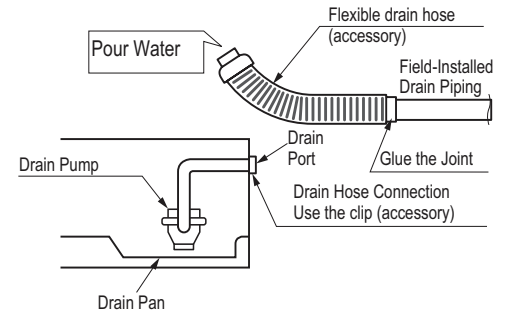
Do not apply force or twist the drain hose, it may leak.

Checking the Drain Pump

The unit uses a drain pump to remove condensate. The pump must be tested before the system operates.

- Connect (field supplied) flexible drain hose to the field-installed drain piping; leave it as is until the test is complete.
- Pour water into the flexible drain hose and check for leaks.
- After power wiring installation is complete, operate the drain pump to see if it sounds and functions properly.
- After the test is complete, connect the flexible drain hose to the indoor unit drain port.

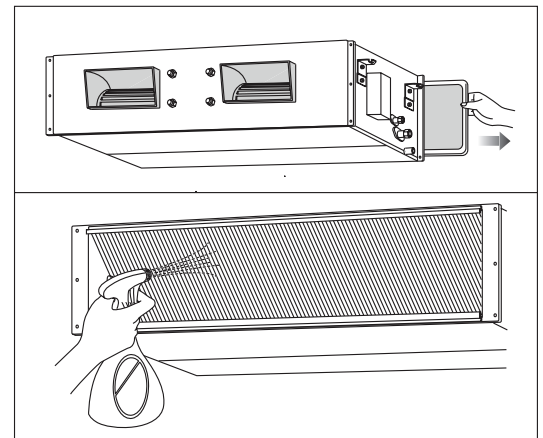
Figure 169: Checking the drain pump.



Checking the Drainage System

1. Remove the air filter.
2. Check the drainage.
 - Spray water on the evaporator.
 - Verify that water flows through the indoor unit drain hose without leaking.

Figure 170: Checking the Drainage System.

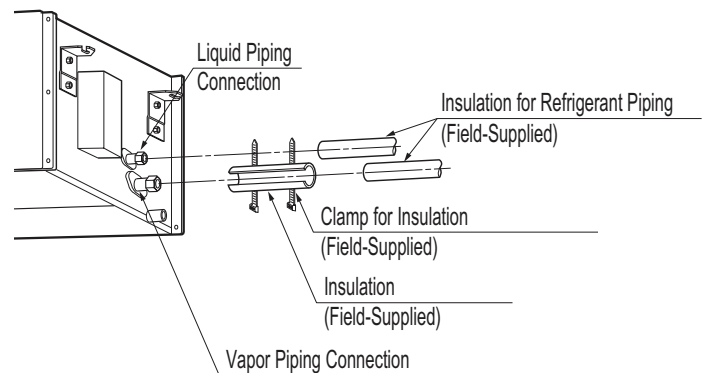


Insulating the Refrigerant and Drain Piping

Refrigerant Piping Insulation

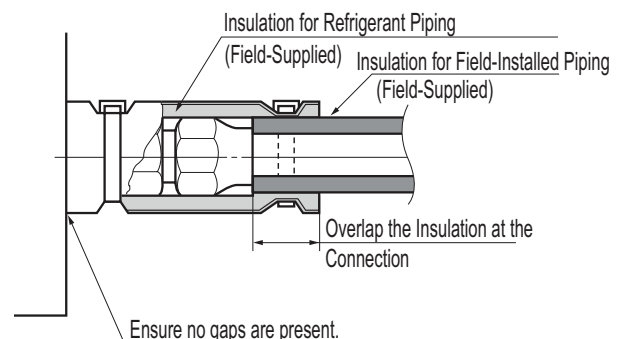
Field-installed vapor and liquid refrigerant piping lines must be properly and completely covered in insulation (up to the indoor unit piping connections). Any exposed piping may generate condensate or will cause burns if touched. Insulation for this field-installed refrigerant piping must have a minimum heat resistance of 248°F.

Figure 171: Insulating the Piping.



Drain Piping Insulation

Drain piping must have insulation a minimum of 7/32 inches thick.



DUCT (HIGH STATIC) INDOOR UNITS

Installation and Best Layout Practices

MULTI F
MULTI F MAX

Power Wiring / Communications Cable Guidelines

- Follow manufacturer's circuit diagrams in the technical manuals.
- Confirm power source specifications.
- Confirm that the electrical capacity is sufficient.
- Starting current must be maintained ± 10 percent of the rated current marked on the outdoor unit name plate.
- Confirm cable thickness specifications.
- It is recommended that a circuit breaker is installed, especially if conditions could become wet or moist.
- Include a disconnect in the power wiring system, add an air gap contact separation of at least 1/8 inch in each active (phase) conductor.

⚠ WARNING

- Loose wiring may cause unit malfunction, or the terminal to overheat and catch fire.
- Terminal screws may become loose during transport. Properly tighten the terminal connections during installation.

A voltage drop may cause the following problems:

- Magnetic switch vibration, fuse breaks, or disturbance to the normal function of an overload protection device.
- Compressor will not receive the proper starting current.

Connecting the Power Wiring and Communications Cable

1. To access the terminal block, first unscrew the cover from the control box.
2. Insert the power wiring / communications cable from the outdoor unit or branch distribution unit (Multi F MAX systems only) through the sides of the indoor unit and control box. Pass the wiring through the designated access holes to prevent damage. To prevent electromagnetic interference and product malfunction, leave a space between the power wiring and communications cable outside of the indoor unit.
3. Connect each wire to its appropriate terminal on the indoor unit control board. Verify that the color and terminal numbers from the outdoor unit or branch distribution unit (Multi F MAX systems only) wiring match the color and terminal numbers on the indoor unit.
4. Secure the power wiring / communications cable with the cable restraint.
5. Screw the steel clamp to the inside of the control panel.
 - Place the wiring / cables in the clamp and tighten the plastic clamp to an open surface of the control panel.
 - When clamping, do not apply force to the wiring connections.
 - Neatly arrange the wiring, do not catch the wiring in the electric box cover, and ensure the cover firmly closes.
6. Fill in any gaps around the wiring access holes with sealant to prevent foreign particles from entering the indoor unit.

Figure 172: Accessing the Indoor Unit Terminal Block.

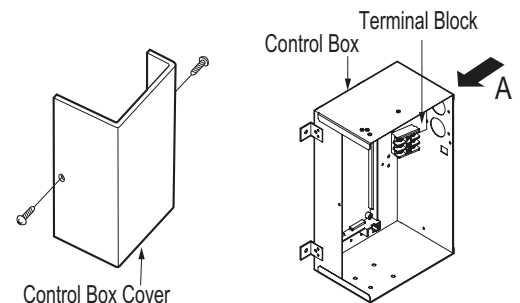
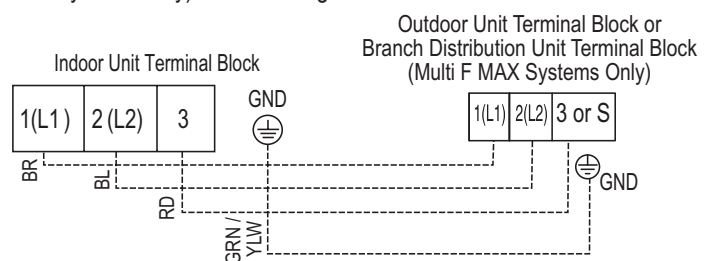


Figure 173: Indoor Unit to Outdoor Unit / Branch Distribution Unit (Multi F MAX systems only) Power Wiring / Communications Cable Connections.



Using a Conduit

1. Remove the rubber stopper on the indoor unit. Pass the power wiring / communications cable through the conduit, the conduit mounting plate, and to / through the control panel of the indoor unit.
2. Connect the power wiring / communications cable to the indoor unit terminal block.
3. Screw the conduit mounting plate to the indoor unit.
4. Tighten the conduit and the conduit mounting plate together.

Note:

If the distance between the outdoor unit and indoor unit is greater than 131 feet, connect the power wiring and communications cable separately (i.e., a conduit cannot be used).

Controller Options

Ceiling-concealed duct (high static) indoor units include an LG-supplied wired controller (AKB72955816)¹, but other optional LG-supplied wired controllers are available (see Controls and Options overview on pages 9 to 12 in this manual's Introduction section). The wireless handheld controller (Model No. PQWRHQ0FDB) is also an optional accessory with use of the wired controller.

- Operation Display Panel: Displays operation conditions.
- Temperature Control Button: Sets desired temperature.
- Fan Speed Button: Sets desired fan speed.
- On / Off Button: Turns system operation on and off.
- Mode Selection Check Button: Selects the operation mode: Cooling, Heating, Auto, Dry (Dehumidification), or Fan.

Note:

Each function will display on the LED for about three (3) seconds when the power is first cycled on.

¹Simple Mode Controllers for the ceiling-concealed duct (high static) indoor units are also referenced by Model No. PQRCVCL0QW.

Wired Controller Connections

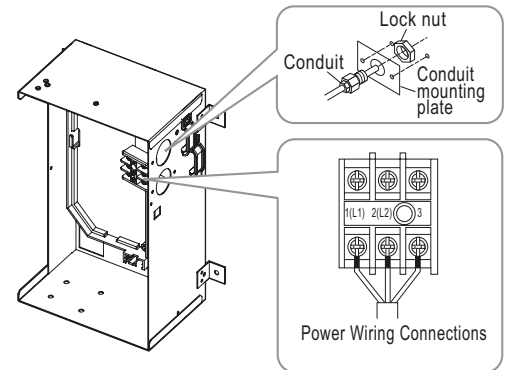
Controllers can connect to the indoor unit in one of two different ways.

1. LG Wired Remote Extension Cable with Molex plug (PZCWRC1; sold separately) that connects to the CN-REMO terminal on the indoor unit PCB.
2. Field-supplied controller cable that connects to the indoor unit terminal block (must be at least UL2547 or UL1007, 22 AWG, two-core, one-shield core, at least FT-6 rated if local electric and building codes require plenum cable usage).

Note:

When using field-supplied controller cable, make sure to connect the yellow to yellow (communications wire), red to red (12V power wire), and black to black (ground wire) terminals from the remote controller to the indoor unit terminal blocks.

Figure 174: Exterior View of Conduit Installation.



Wired Controller

Figure 175: AKB72955816¹ Wired Controller.

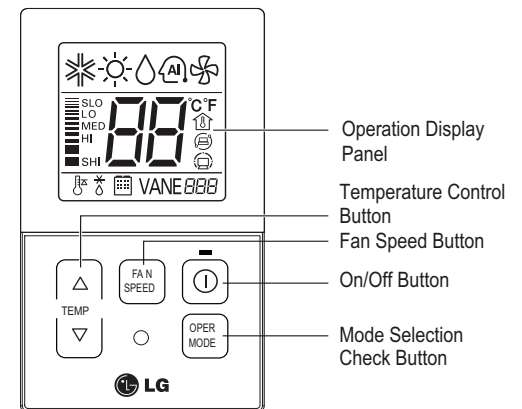


Figure 176: PZCWRC1 LG Wired Remote Extension Cable.

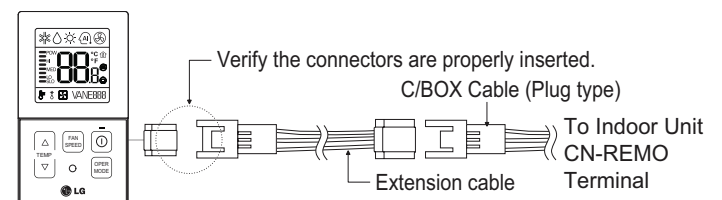
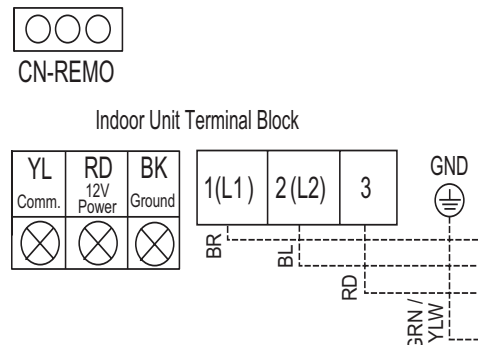


Figure 177: Wired Controller Connections on the Indoor Unit Terminal Block.



DUCT (HIGH STATIC) INDOOR UNITS

Installation and Best Layout Practices

MULTI F
MULTI F MAX

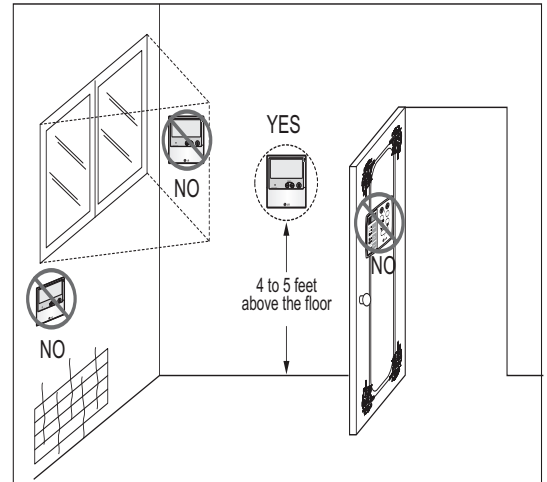
Wired Controller Placement

Wired controllers include a sensor to detect room temperature. To maintain comfort levels in the conditioned space, the wired controller must be installed in a location away from direct sunlight, high humidity, and where it could be directly exposed to cold air. Controller must be installed four (4) to five (5) feet above the floor where its LED display can be read easily, in an area with good air circulation, and where it can detect an average room temperature.

Do not install the wired controller near or in:

- Drafts or dead spots behind doors and in corners
- Hot or cold air from ducts
- Radiant heat from the sun or appliances
- Concealed pipes and chimneys
- An area where temperatures are uncontrolled, such as an outside wall

Figure 178: Proper Location for the Wired Controller.



Hanging the Wired Controller

1. The controller wiring / cable can be installed in one of three directions: top, back, or on the right side. If top or right side installation is desired, remove cable guide grooves on the controller, and then position wiring / cable on applicable side.
2. Choose and mark the area of installation, and then screw the wall plate into place (using the provided parts). Install the controller wall plate to fit the electrical box if one is present. Ensure that no gaps exist between the wall plate and the wall itself.
3. Arrange wiring / cables so as not to interfere with the controller circuitry. Position the wired controller on the wall plate. Snap into place by pressing the bottom part of the wired controller onto the wall plate. Make sure that no gaps exist between the wired controller and the wall plate on all sides.
4. To remove wired controller from the wall plate, insert a screwdriver into the two holes at the bottom. Twist screwdriver to release controller. Do not damage the controller components when removing.

Figure 179: Removing the Cable Guide Grooves.

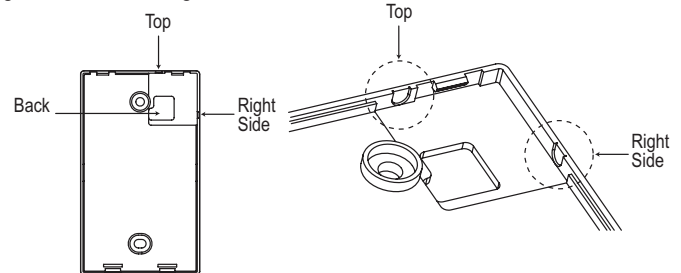


Figure 180: Attaching the Wall Plate.

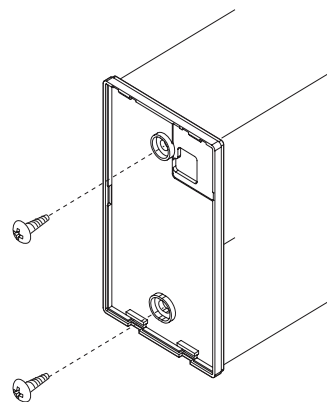
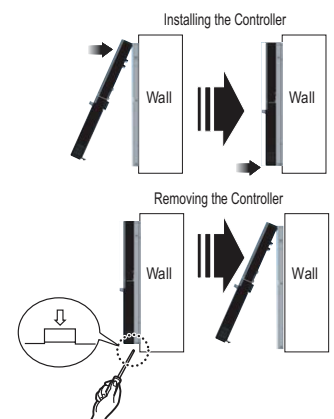


Figure 181: Installing / Removing the Controller.



Assigning the Thermistor for Temperature Detection

Each indoor unit includes a return air thermistor assigned to sense the temperature. If a wired controller is installed, there is a choice of sensing temperature with either the indoor unit return air thermistor or the thermistor in the wired controller. It is also an option to set both thermistors to sense temperature so that indoor unit bases its operation on the first thermistor to reach the designated temperature differential. For applicable indoor units, an optional Remote Temperature Sensor can be used in lieu of the return air thermistor—either alone or in conjunction with a wired controller thermistor as previously described.

External Static Pressure Control

To provide a required air flow rate that accounts for the external static pressure change, follow the steps below.

1. To access system installer setting mode, press and hold the temperature increase and mode selection buttons simultaneously for approximately three (3) seconds. Choose setting code value "06" by pressing the mode selection button.

2. Use the temperature increase and decrease buttons to select the desired setting value.

Setting Values

- 01 : V-H 03 : V-L
- 02 : F-H 04 : F-L

3. Press the on / off button to save the established settings.

4. To deactivate system installer setting mode after the settings have been established, press and hold the temperature increase and mode selection check buttons simultaneously for approximately three (3) seconds. If a button is not pressed for more than 25 seconds, the system installer setting mode will automatically deactivate.

Figure 182: Select Code and Set Value.

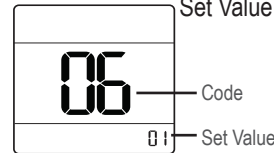


Figure 183: Controller External Static Pressure Setting Display.

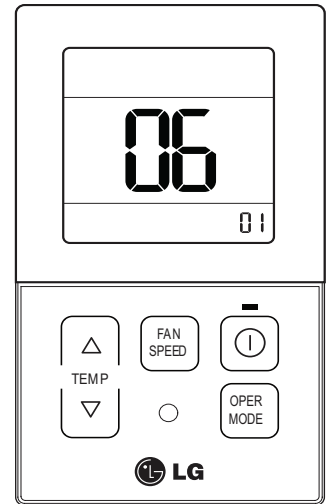


Table 70: Static Pressure Setting Table.

Pressure Selection		Function	
		Zone State	External Static Pressure Standard Value
01	V-H	Variable	High
02	F-H	Fixed	High
03	V-L	Variable	Low
04	F-L	Fixed	Low

Note:

- Select the position after verifying duct work and the external static pressure of the indoor unit.
- Factory set to pressure selection F-H.

DUCT (HIGH STATIC) INDOOR UNITS

Installation and Best Layout Practices

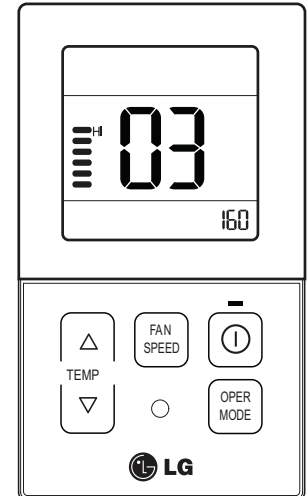
MULTI F
MULTI F MAX

Assigning Air Flow

To assign an air flow for each fan speed, follow the steps below.

1. To access system installer setting mode, press and hold the temperature increase and mode selection buttons simultaneously for approximately three (3) seconds. Choose setting code value "03" by pressing the mode selection button.
2. Use the fan speed button to select the desired fan speed. (Lo→Med→Hi will display on the LED).
3. Use the temperature increase and decrease buttons to select the desired external static pressure setting value (thereby assigning the respective airflow). External static pressure value range: 0~255; the value will display near the lower right corner of the LED.
4. Press the on / off button to save the established settings.
5. To deactivate system installer setting mode after the settings have been established, press and hold the temperature increase and mode selection check buttons simultaneously for approximately three (3) seconds. If a button is not pressed for more than 25 seconds, the system installer setting mode will automatically deactivate.

Figure 184: Controller External Static Pressure Setting Display.



Note:

- A certified technician must set the external static pressure value(s). If the external static pressure is set incorrectly, the system may malfunction.
- Do not alter the external static pressure value that corresponds to each air flow level.
- External static pressure value can vary depending on the indoor unit.
- If by pressing the fan speed button during external static pressure setup, the fan speed is raised to the next level, the air flow value of the previous fan speed will be maintained (external static pressure setting value is saved).

FOUR-WAY CEILING-CASSETTE INDOOR UNIT DATA

“Mechanical Specifications” on page 130

“General Data / Specifications” on page 131

“Dimensions” on page 132

“Cooling Capacity Table” on page 134

“Heating Capacity Table” on page 136

“Acoustic Data” on page 138

“Air Velocity and Temperature Distribution” on page 140

“Refrigerant Flow Diagram” on page 142

“Wiring Diagram” on page 143

“Factory Supplied Parts and Materials” on page 144

“Installation and Best Layout Practices” on page 145

FOUR-WAY CEILING CASSETTE INDOOR UNITS

MULTI F
MULTI F MAX

Mechanical Specifications and Features

Four-Way Ceiling-Cassette Indoor Units

General

All LG indoor units are factory assembled, wired, piped, and provided with a control circuit board, fan, and motor. Four-way ceiling-cassette units have a sound rating no higher than 38 dB(A) as tested per KSA0701 ISO Standard 3745.

Coil

Indoor unit coils are factory built and are comprised of aluminum fins mechanically bonded to copper tubing. Each unit has two rows of coils, which are pressure tested at the factory. Each unit is provided with a factory installed condensate drain pan below the coil.

Refrigerant System

System is designed for use with R410A refrigerant. The refrigeration circuit is pressure-tested at the factory and shipped with a holding charge of helium gas. Refrigerant pipe connections are 45° flare, and all refrigerant lines from the outdoor unit to the indoor units must be field insulated.

Electrical

Each indoor unit is designed to operate using 208–230/60/1 power with voltage variances of ±10%.

Casing

The case is constructed of a galvanized steel plate designed to recess in the ceiling, and has a surface mounted concentric grille on the bottom of the unit. Unit has four supply air outlets and one return air inlet.

Ventilation Air

The case has a factory designated knockouts to connect a field-supplied, pressurized, and filtered outside air duct.

Fan Assembly and Control

All indoor units have a single, direct-drive turbo fan. Fans are manufactured of high-strength ABS HT-700 polymeric resin that is statically and dynamically balanced. The fan motor is brushless digitally controlled (BLDC) with permanently lubricated and sealed ball bearings. The fan / motor assembly is mounted on vibration-attenuating rubber grommets. Fan speed is controlled using a microprocessor-based direct digital control algorithm that provides pre-programmed, field-selectable fixed or auto fan speeds in the Heating and Cooling modes.

The indoor fan has Low, Med, High, Power Cool and Auto settings for Cooling mode; and has Low, Med, High, and Auto settings for Heating mode. Auto setting adjusts the fan speed based on the difference between the controller setpoint and space temperature.

Air Filter

Return air is filtered with a factory-supplied, removable, washable

Features

- Inverter (Variable speed fan)
- Internal drain pump
- Jet cool
- Control lock function
- Auto operation
- Auto restart operation
- 24-Hour on/off timer
- Two thermistor control
- Required accessory grille (PT-UQC) sold separately
- Group Control
- Plasma kit (PTPKQ0) sold separately
- Wireless LCD remote control included; wired thermostat available (sold separately)

filter accessible from the bottom of the unit. A plasma filter is also available as an optional accessory.

Architectural Grille

An architectural grille is sold as a separate required accessory. The four-way grille is off-white acrylonitrile butadiene styrene (ABS) polymeric resin with a tapered trim edge.

Airflow Guide Vanes

The supply air outlet has four-directional slot diffusers, each equipped with an independent oscillating motorized guide vane to change airflow direction. A guide vane algorithm sequentially changes the predominant discharge airflow direction in counterclockwise pattern, or can be used to lock each guide vane independently in a field-adjusted fixed position. The four vanes can be individually adjusted from the wired remote controller to customize the airflow pattern for the conditioned space. A setting in the cooling and heating modes can cycle the vanes up and down for uniform / random air distribution.

Microprocessor Control

The indoor unit is provided with an integrated control panel to communicate with the outdoor unit. All unit operation parameters are stored in non-volatile memory residing on the unit microprocessor. The microprocessor controls space temperature through using the value provided by the temperature sensor within the indoor unit. The microprocessor control will activate indoor unit operation when the indoor room temperature falls below or rises above a setpoint temperature, at which point, a signal is sent to the outdoor unit to begin the appropriate mode. The microprocessor will also provide self-diagnostics and auto restart functions. A field-supplied four-wire power / communications cable must be installed to connect the indoor unit(s) to the outdoor unit.

Controls

The indoor unit casing has a factory-standard, integral infrared sensor designed to communicate with the supplied LG wireless handheld remote controller. An optional wired controller is available as an additional accessory. Communication between the indoor units and the outdoor unit is accomplished through 18 AWG, four-core, stranded and shielded power / communication cable.

Condensate Lift/Pump

The indoor unit is provided with a factory installed and wired internal condensate lift/pump capable of providing a minimum 27.5 inch lift from the bottom surface of the unit. Drain pump has a safety switch to shut off the indoor unit if the condensate rises too high in the drain pan.

Figure 185: Multi F Four-Way Ceiling-Cassette Indoor Unit.



Table 71: Multi F Four-Way Ceiling-Cassette Indoor Unit General Data.

Model Name	LMCN077HV	LMCN097HV	LMCN125HV	LMCN185HV
Nominal Cooling Capacity (Btu/h) ¹	7,000	9,000	12,000	18,000
Nominal Heating Capacity (Btu/h) ¹	8,100	10,400	13,800	20,800
Operating Range				
Cooling (°F WB)	57-77			
Heating (°F DB)	59-81			
Fan				
Type	Turbo			
Motor Output (W) x Qty.	43 x 1			
Motor/Drive	Brushless Digitally Controlled / Direct			
Airflow Rate CFM (H/M/L)	265 / 212 / 177	300 / 265 / 230	335 / 283 / 247	459 / 424 / 388
Unit Data				
Refrigerant Type ²	R410A			
Refrigerant Control	EEV			
Power Supply V, Ø, Hz ³	208-230, 1, 60			
Rated Amps (A)	0.25			
Sound Pressure Level ±3 dB(A) (H/M/L) ⁴	31 / 27 / 24	36 / 33 / 30	38 / 35 / 32	38 / 37 / 34
Body Dimensions (W x H x D, in.)	22-7/16 x 8-7/16 x 22-7/16			22-7/16 x 10-3/32 x 22-7/16
Grille (PT-UQC, sold separately) Dimensions (WxHxD, in.)	27-9/16 x 7/8 x 27-9/16			
Body Net Weight (lbs.)	31			34
Grille (PT-UQC, sold separately) Net Weight (lbs.)	7			
Body Shipping Weight (lbs.)	34	36	40	42
Grille (PT-UQC, sold separately) Shipping Weight (lbs.)	11			11
Power Wiring / Communications Cable (No. x AWG) ⁵	4 x 18			
Heat Exchanger (Row x Column x Fin / inch) x Number	(2 x 8 x 18) x 1			(2 x 10 x 18) x 1
Piping				
Liquid (in.)	1/4			1/4
Vapor (in.)	3/8			1/2
Drain O.D. / I.D. (in.)	1-1/4, 1			

¹Nominal capacity is rated 0 ft. above sea level with a 0 ft. level difference between outdoor and indoor units. All capacities are net with a combination ratio between 95 – 105%.

Nominal cooling capacity rating obtained with air entering the indoor unit at 80°F dry bulb (DB) and 67°F wet bulb (WB) and outdoor ambient conditions of 95°F dry bulb (DB) and 75°F wet bulb (WB).

Nominal heating capacity rating obtained with air entering the indoor unit at 70°F dry bulb (DB) and 60°F wet bulb (WB) and outdoor ambient conditions of 47°F dry bulb (DB) and 43°F wet bulb (WB).

²This unit comes with a dry helium charge.

³Acceptable operating voltage: 187V-253V.

⁴Sound pressure levels are tested in an anechoic chamber under ISO Standard 3745 and are the same in both cooling and heating mode. These values can increase due to ambient conditions during operation.

⁵All power wiring / communications cables to be minimum 18 AWG, 4-conductor, stranded, shielded, and must comply with applicable local and national codes.

FOUR-WAY CEILING CASSETTE INDOOR UNITS

MULTI F
MULTI F MAX

Dimensions

Figure 186: LMCN077HV, LMCN097HV, and LMCN125HV Dimensions.

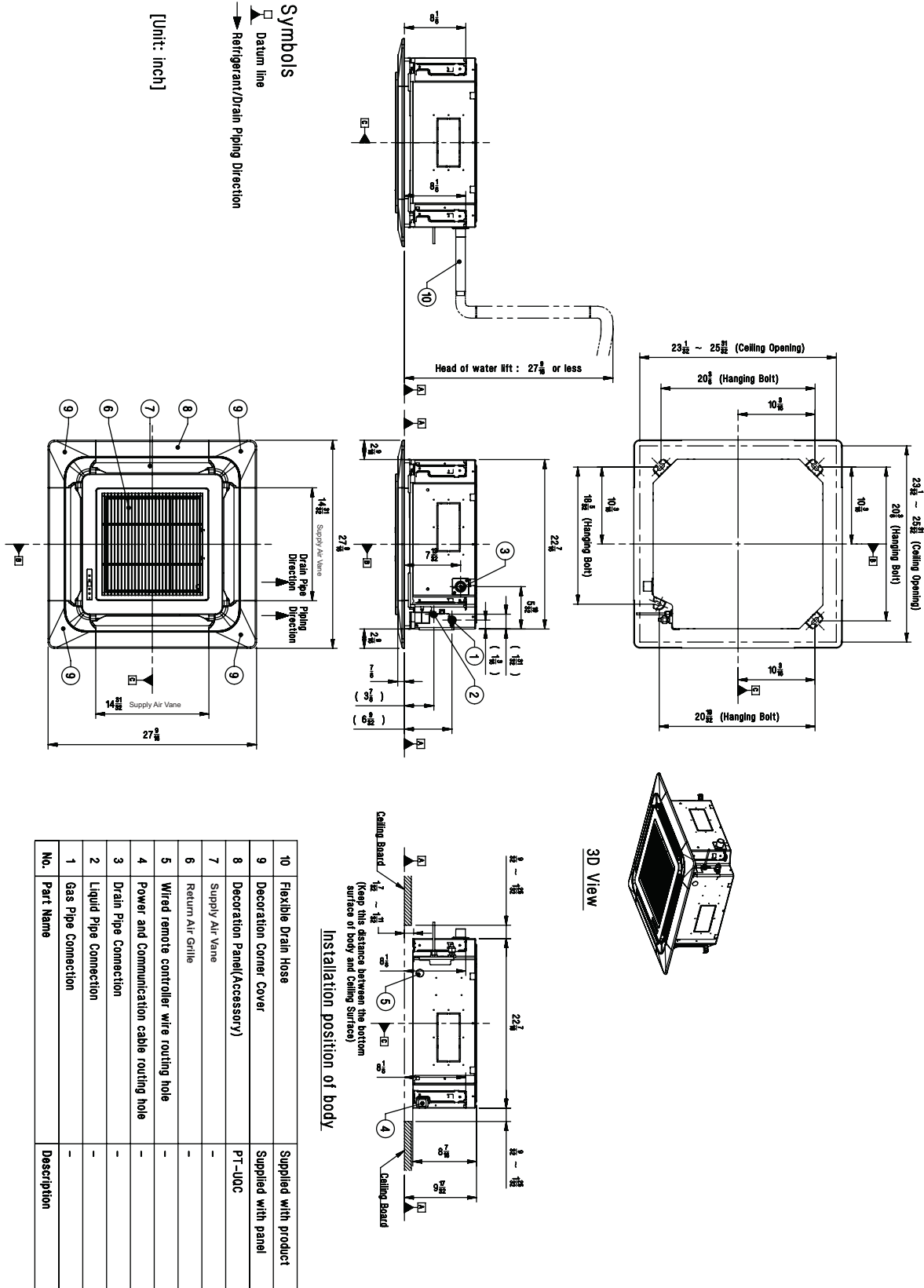
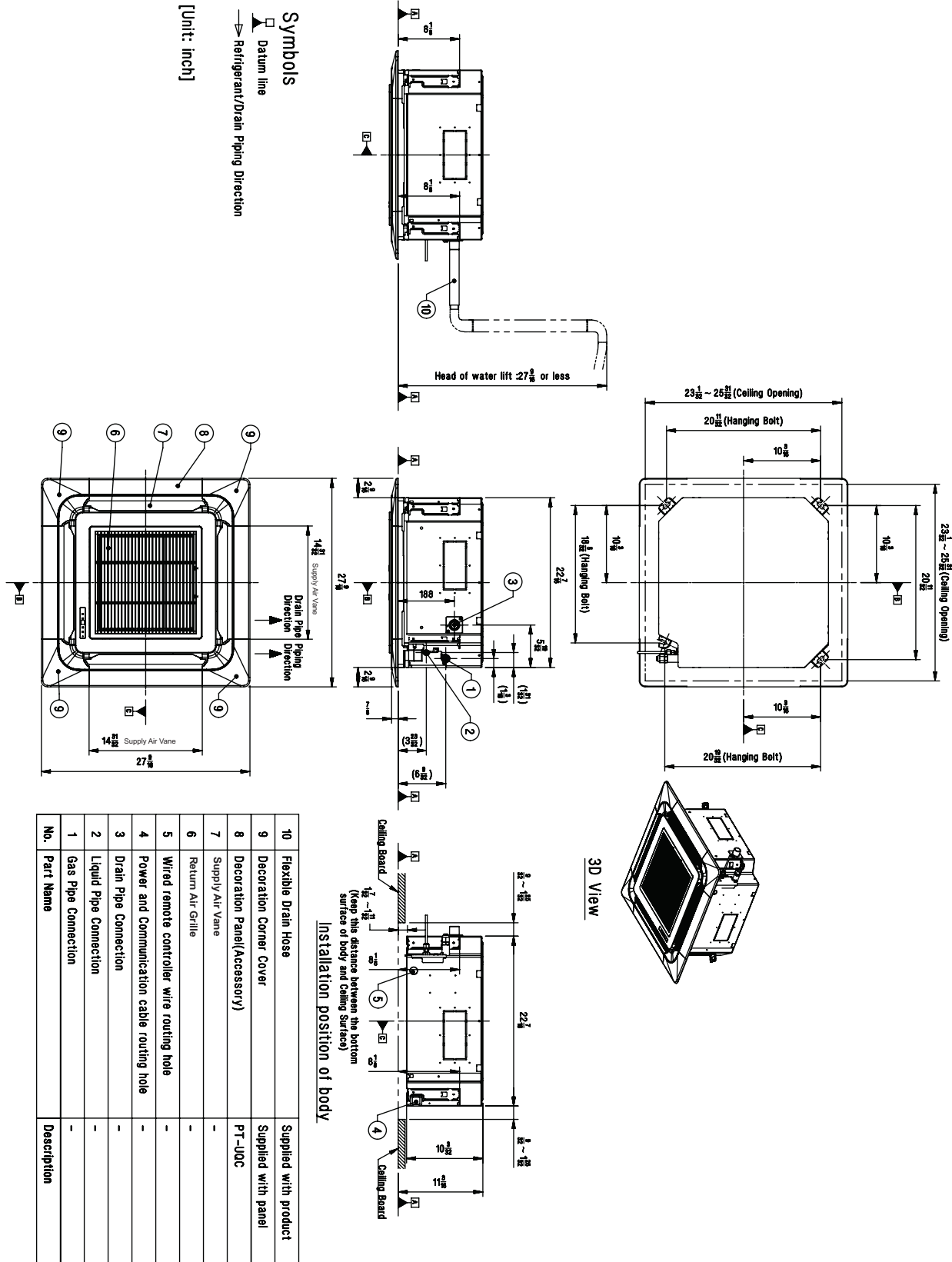


Figure 187: LMCN185HV Dimensions.



FOUR-WAY CEILING CASSETTE INDOOR UNITS

MULTI F
MULTI F MAX

Cooling Capacity Table

Table 72: Multi F Four-Way Ceiling-Cassette Indoor Units Cooling Capacity Table.

Model No. / Nominal Capacity of Indoor Unit (Btu/h)	Outdoor Air Temp. (°F DB)	Indoor Air Temp. °F DB / °F WB											
		68 / 57		73 / 61		77 / 64		80 / 67		86 / 72		90 / 75	
		TC	SHC	TC	SHC	TC	SHC	TC	SHC	TC	SHC	TC	SHC
LMCN077HV 7,000	14	6.86	4.87	7.29	5.15	7.71	4.99	8.02	5.09	8.57	5.13	8.99	5.23
	20	6.86	4.91	7.28	5.19	7.71	5.02	8.02	5.13	8.56	5.17	8.99	5.27
	25	6.85	4.95	7.28	5.23	7.70	5.06	8.01	5.17	8.55	5.21	8.98	5.31
	30	6.85	4.99	7.27	5.27	7.70	5.10	8.00	5.21	8.55	5.25	8.97	5.35
	35	6.84	5.03	7.27	5.31	7.69	5.14	8.00	5.25	8.54	5.29	8.97	5.39
	40	6.84	5.06	7.26	5.35	7.68	5.18	7.99	5.29	8.53	5.33	8.96	5.43
	45	6.83	5.10	7.25	5.39	7.68	5.22	7.99	5.33	8.53	5.37	8.95	5.47
	50	6.83	5.14	7.25	5.43	7.67	5.26	7.98	5.37	8.52	5.41	8.94	5.52
	55	6.82	5.18	7.24	5.47	7.67	5.30	7.97	5.41	8.51	5.45	8.94	5.56
	60	6.81	5.21	7.24	5.51	7.66	5.33	7.97	5.45	8.51	5.49	8.93	5.60
	65	6.81	5.25	7.23	5.55	7.66	5.37	7.96	5.49	8.50	5.53	8.92	5.64
	70	6.80	5.29	7.23	5.59	7.65	5.41	7.95	5.52	8.49	5.57	8.92	5.68
	75	6.64	5.20	7.06	5.50	7.48	5.33	7.79	5.45	8.33	5.50	8.75	5.61
	80	6.48	5.11	6.90	5.42	7.32	5.26	7.62	5.38	8.16	5.43	8.58	5.55
	85	6.31	5.02	6.73	5.33	7.15	5.17	7.46	5.30	7.99	5.36	8.41	5.48
	90	6.15	4.93	6.57	5.23	6.99	5.09	7.29	5.21	7.83	5.29	8.24	5.40
	95	5.98	4.87	6.39	5.19	6.81	5.05	7.00	5.10	7.64	5.26	8.06	5.38
	100	5.83	4.74	6.25	5.05	6.66	4.93	6.91	5.02	7.50	5.14	7.91	5.27
	105	5.69	4.61	6.10	4.92	6.52	4.81	6.82	4.94	7.35	5.03	7.77	5.16
	110	5.54	4.46	5.96	4.76	6.37	4.66	6.67	4.79	7.21	4.89	7.62	5.02
115	5.39	4.32	5.81	4.63	6.23	4.54	6.53	4.67	7.06	4.77	7.48	4.90	
118	5.31	4.29	5.72	4.60	6.14	4.52	6.44	4.65	6.97	4.76	7.39	4.89	
122	5.28	4.28	5.69	4.59	6.11	4.51	6.41	4.64	6.94	4.75	7.36	4.89	
LMCN097HV 9,000	14	8.82	6.31	9.37	6.66	9.92	6.45	10.31	6.59	11.01	6.64	11.56	6.77
	20	8.82	6.36	9.36	6.72	9.91	6.50	10.31	6.64	11.01	6.70	11.55	6.82
	25	8.81	6.41	9.36	6.77	9.90	6.55	10.30	6.69	11.00	6.75	11.54	6.87
	30	8.80	6.46	9.35	6.82	9.90	6.60	10.29	6.74	10.99	6.80	11.54	6.93
	35	8.80	6.50	9.34	6.87	9.89	6.65	10.28	6.79	10.98	6.85	11.53	6.98
	40	8.79	6.55	9.33	6.92	9.88	6.70	10.27	6.84	10.97	6.90	11.52	7.03
	45	8.78	6.60	9.33	6.97	9.87	6.75	10.27	6.90	10.96	6.95	11.51	7.09
	50	8.78	6.65	9.32	7.03	9.87	6.80	10.26	6.95	10.96	7.00	11.50	7.14
	55	8.77	6.70	9.31	7.08	9.86	6.85	10.25	7.00	10.95	7.06	11.49	7.19
	60	8.76	6.75	9.31	7.13	9.85	6.90	10.24	7.05	10.94	7.11	11.48	7.24
	65	8.76	6.80	9.30	7.18	9.84	6.95	10.24	7.10	10.93	7.16	11.47	7.29
	70	8.75	6.85	9.29	7.23	9.84	7.00	10.23	7.15	10.92	7.21	11.47	7.35
	75	8.54	6.73	9.08	7.12	9.62	6.90	10.01	7.05	10.71	7.12	11.25	7.26
	80	8.33	6.62	8.87	7.01	9.41	6.80	9.80	6.96	10.49	7.03	11.03	7.18
	85	8.12	6.50	8.66	6.89	9.20	6.70	9.59	6.85	10.28	6.94	10.82	7.09
	90	7.91	6.37	8.45	6.77	8.99	6.59	9.37	6.75	10.06	6.84	10.60	6.99
	95	7.68	6.31	8.22	6.71	8.75	6.54	9.00	6.60	9.83	6.80	10.36	6.96
	100	7.50	6.14	8.03	6.54	8.57	6.38	8.88	6.50	9.64	6.66	10.17	6.82
	105	7.31	5.97	7.84	6.37	8.38	6.23	8.77	6.40	9.45	6.51	9.99	6.68
	110	7.12	5.77	7.66	6.17	8.19	6.03	8.58	6.20	9.26	6.33	9.80	6.50
115	6.94	5.59	7.47	5.99	8.01	5.87	8.39	6.05	9.08	6.18	9.61	6.35	
118	6.82	5.55	7.36	5.96	7.89	5.84	8.28	6.02	8.96	6.15	9.50	6.33	
122	6.79	5.54	7.32	5.94	7.86	5.83	8.24	6.01	8.93	6.15	9.46	6.32	

TC = Total Capacity (kBtu/h).

SHC: Sensible Heat Capacity (kBtu/h).

Nominal capacity as rated 0 ft. above sea level and a 0 ft. level difference between outdoor and indoor units. Corresponding refrigerant piping length is accordance with standard length of each outdoor unit.

Nominal cooling capacity rating obtained with air entering the indoor unit at 80°F dry bulb (DB) and 67°F wet bulb (WB), and outdoor ambient conditions of 95°F dry bulb (DB) and 75°F wet bulb (WB).

The shaded table columns and rows indicate reference data. When operating at this temperature, these values can be different if the system is not running consistently.

Multi F and Multi F MAX Indoor Unit Engineering Manual

Table 73: Multi F Four-Way Ceiling-Cassette Indoor Units Cooling Capacity Table.

Model No. / Nominal Capacity of Indoor Unit (Btu/h)	Outdoor Air Temp. (°F DB)	Indoor Air Temp. °F DB / °F WB											
		68 / 57		73 / 61		77 / 64		80 / 67		86 / 72		90 / 75	
		TC	SHC	TC	SHC	TC	SHC	TC	SHC	TC	SHC	TC	SHC
LMCN125HV 12,000	14	11.76	8.51	12.49	8.99	13.22	8.70	13.75	8.88	14.69	8.96	15.42	9.13
	20	11.75	8.57	12.48	9.06	13.21	8.77	13.74	8.95	14.67	9.03	15.40	9.20
	25	11.75	8.64	12.48	9.13	13.20	8.84	13.73	9.02	14.66	9.10	15.39	9.27
	30	11.74	8.71	12.47	9.20	13.19	8.90	13.72	9.09	14.65	9.17	15.38	9.34
	35	11.73	8.77	12.46	9.27	13.18	8.97	13.71	9.16	14.64	9.24	15.37	9.41
	40	11.72	8.84	12.45	9.34	13.17	9.04	13.70	9.23	14.63	9.31	15.36	9.48
	45	11.71	8.90	12.44	9.41	13.16	9.11	13.69	9.30	14.62	9.38	15.35	9.55
	50	11.70	8.97	12.43	9.47	13.15	9.17	13.68	9.37	14.61	9.45	15.33	9.62
	55	11.69	9.03	12.42	9.54	13.14	9.24	13.67	9.44	14.60	9.52	15.32	9.70
	60	11.68	9.10	12.41	9.61	13.13	9.31	13.66	9.50	14.59	9.58	15.31	9.77
	65	11.67	9.17	12.40	9.68	13.12	9.38	13.65	9.57	14.57	9.65	15.30	9.84
	70	11.66	9.23	12.39	9.75	13.11	9.44	13.64	9.64	14.56	9.72	15.29	9.91
	75	11.38	9.08	12.11	9.60	12.83	9.31	13.35	9.51	14.27	9.60	15.00	9.79
	80	11.10	8.92	11.82	9.45	12.55	9.17	13.07	9.38	13.99	9.48	14.71	9.68
	85	10.83	8.76	11.54	9.29	12.26	9.03	12.78	9.24	13.70	9.36	14.42	9.56
	90	10.55	8.60	11.26	9.13	11.98	8.88	12.50	9.10	13.42	9.22	14.13	9.43
	95	10.25	8.51	10.96	9.05	11.67	8.82	12.00	8.90	13.10	9.18	13.81	9.39
	100	10.00	8.28	10.71	8.82	11.42	8.61	11.84	8.76	12.85	8.98	13.56	9.20
105	9.75	8.05	10.46	8.59	11.17	8.40	11.69	8.62	12.60	8.78	13.31	9.01	
110	9.50	7.77	10.21	8.31	10.92	8.14	11.44	8.37	12.35	8.53	13.07	8.76	
115	9.25	7.54	9.96	8.08	10.67	7.92	11.19	8.15	12.10	8.33	12.82	8.56	
118	9.10	7.49	9.81	8.03	10.52	7.88	11.04	8.12	11.95	8.30	12.67	8.54	
122	9.05	7.47	9.76	8.01	10.48	7.87	10.99	8.11	11.90	8.29	12.62	8.53	
LMCN185HV 18,000	14	17.65	12.33	18.74	13.02	19.84	12.61	20.63	12.88	22.03	12.98	23.12	13.23
	20	17.63	12.43	18.73	13.13	19.82	12.71	20.61	12.98	22.01	13.09	23.11	13.33
	25	17.62	12.52	18.71	13.23	19.81	12.81	20.60	13.08	22.00	13.19	23.09	13.44
	30	17.60	12.62	18.70	13.33	19.79	12.91	20.58	13.18	21.98	13.29	23.07	13.54
	35	17.59	12.71	18.68	13.43	19.78	13.00	20.57	13.28	21.96	13.39	23.05	13.64
	40	17.58	12.81	18.67	13.53	19.76	13.10	20.55	13.38	21.94	13.49	23.04	13.75
	45	17.56	12.90	18.66	13.63	19.75	13.20	20.53	13.48	21.93	13.59	23.02	13.85
	50	17.55	13.00	18.64	13.73	19.73	13.30	20.52	13.58	21.91	13.69	23.00	13.95
	55	17.54	13.10	18.63	13.83	19.72	13.39	20.50	13.68	21.89	13.79	22.98	14.05
	60	17.52	13.19	18.61	13.93	19.70	13.49	20.49	13.78	21.88	13.89	22.97	14.16
	65	17.51	13.29	18.60	14.03	19.69	13.59	20.47	13.87	21.86	13.99	22.95	14.26
	70	17.50	13.38	18.58	14.13	19.67	13.69	20.46	13.97	21.84	14.09	22.93	14.36
	75	17.08	13.16	18.16	13.92	19.24	13.49	20.03	13.79	21.41	13.92	22.50	14.20
	80	16.66	12.93	17.74	13.70	18.82	13.30	19.60	13.60	20.98	13.75	22.06	14.03
	85	16.24	12.70	17.32	13.47	18.40	13.09	19.17	13.40	20.55	13.56	21.63	13.85
	90	15.82	12.46	16.90	13.23	17.97	12.88	18.75	13.19	20.12	13.37	21.20	13.67
	95	15.37	12.33	16.44	13.12	17.51	12.78	18.00	12.90	19.65	13.30	20.72	13.61
	100	14.99	12.00	16.06	12.78	17.13	12.47	17.77	12.70	19.28	13.01	20.35	13.33
105	14.62	11.67	15.69	12.45	16.76	12.17	17.53	12.50	18.90	12.73	19.97	13.05	
110	14.24	11.27	15.32	12.05	16.39	11.79	17.16	12.13	18.53	12.36	19.60	12.70	
115	13.87	10.93	14.94	11.71	16.01	11.48	16.79	11.82	18.15	12.07	19.22	12.41	
118	13.65	10.85	14.72	11.64	15.79	11.42	16.56	11.77	17.93	12.03	19.00	12.37	
122	13.57	10.83	14.64	11.62	15.71	11.40	16.49	11.75	17.85	12.01	18.92	12.36	

TC = Total Capacity (kBtu/h).

SHC: Sensible Heat Capacity (kBtu/h).

Nominal capacity as rated 0 ft. above sea level and a 0 ft. level difference between outdoor and indoor units. Corresponding refrigerant piping length is accordance with standard length of each outdoor unit.

Nominal cooling capacity rating obtained with air entering the indoor unit at 80°F dry bulb (DB) and 67°F wet bulb (WB), and outdoor ambient conditions of 95°F dry bulb (DB) and 75°F wet bulb (WB).

The shaded table columns and rows indicate reference data. When operating at this temperature, these values can be different if the system is not running consistently.

Four-Way Ceiling-Cassette

FOUR-WAY CEILING-CASSETTE INDOOR UNITS

MULTI F
MULTI F MAX

Heating Capacity Table

Table 74: Multi F Four-Way Ceiling-Cassette Indoor Units Heating Capacity Table.

Model No. / Nominal Capacity of Indoor Unit (Btu/h)	Outdoor Air Temp.		Indoor Air Temp. °F DB					
	°F DB	°F WB	61	64	68	70	72	75
			TC	TC	TC	TC	TC	TC
LMCN077HV 7,000	0	-0.4	4.17	4.11	4.07	4.05	3.99	3.82
	5	4.5	4.70	4.64	4.60	4.58	4.52	4.34
	10	9	5.22	5.17	5.13	5.11	5.05	4.87
	17	15	5.93	5.87	5.83	5.81	5.75	5.56
	20	19	6.19	6.13	6.09	6.08	6.02	5.81
	25	23	6.63	6.57	6.53	6.52	6.46	6.22
	30	28	7.01	6.96	6.92	6.90	6.84	6.63
	35	32	7.40	7.34	7.30	7.28	7.22	7.04
	40	36	7.74	7.68	7.64	7.62	7.56	7.39
	45	41	8.08	8.02	7.98	7.96	7.90	7.73
	47	43	8.22	8.16	8.12	8.10	8.04	7.87
	50	46	8.35	8.29	8.25	8.23	8.17	7.98
	55	51	8.57	8.51	8.47	8.45	8.39	8.16
	60	56	8.57	8.51	8.47	8.45	8.39	8.20
	63	59	8.57	8.51	8.47	8.45	8.39	8.22
68	64	8.57	8.51	8.47	8.45	8.39	8.25	
LMCN097HV 9,000	0	-0.4	5.35	5.28	5.23	5.20	5.12	4.90
	5	4.5	6.03	5.95	5.90	5.88	5.80	5.58
	10	9	6.71	6.63	6.58	6.56	6.48	6.26
	17	15	7.61	7.54	7.49	7.46	7.39	7.14
	20	19	7.95	7.88	7.83	7.80	7.72	7.46
	25	23	8.52	8.44	8.39	8.37	8.29	7.99
	30	28	9.01	8.93	8.88	8.86	8.78	8.52
	35	32	9.50	9.42	9.37	9.34	9.27	9.04
	40	36	9.94	9.86	9.81	9.78	9.71	9.48
	45	41	10.37	10.30	10.25	10.22	10.15	9.92
	47	43	10.55	10.48	10.43	10.40	10.32	10.10
	50	46	10.72	10.64	10.59	10.57	10.49	10.24
	55	51	11.00	10.93	10.88	10.85	10.78	10.48
	60	56	11.00	10.93	10.88	10.85	10.78	10.52
	63	59	11.00	10.93	10.88	10.85	10.78	10.55
68	64	11.00	10.93	10.88	10.85	10.78	10.60	

TC = Total Capacity (kBtu/h).

Nominal capacity as rated 0 ft. above sea level and a 0 ft. level difference between outdoor and indoor units. Corresponding refrigerant piping length is accordance with standard length of each outdoor unit.

Nominal heating capacity rating obtained with air entering the indoor unit at 70°F dry bulb (DB) and 60°F wet bulb (WB), and outdoor ambient conditions of 47°F dry bulb (DB) and 43°F wet bulb (WB).

Table 75: Multi F Four-Way Ceiling-Cassette Indoor Units Heating Capacity Table.

Model No. / Nominal Capacity of Indoor Unit (Btu/h)	Outdoor Air Temp.		Indoor Air Temp. °F DB					
	°F DB	°F WB	61	64	68	70	72	75
			TC	TC	TC	TC	TC	TC
LMCN125HV 12,000	0	-0.4	7.10	7.00	6.93	6.90	6.80	6.50
	5	4.5	8.00	7.90	7.83	7.80	7.70	7.40
	10	9	8.90	8.80	8.73	8.70	8.60	8.30
	17	15	10.10	10.00	9.93	9.90	9.80	9.48
	20	19	10.55	10.45	10.38	10.35	10.25	9.90
	25	23	11.30	11.20	11.13	11.10	11.00	10.60
	30	28	11.95	11.85	11.78	11.75	11.65	11.30
	35	32	12.60	12.50	12.43	12.40	12.30	12.00
	40	36	13.18	13.08	13.02	12.98	12.88	12.58
	45	41	13.77	13.67	13.60	13.57	13.47	13.17
	47	43	14.00	13.90	13.83	13.80	13.70	13.40
	50	46	14.23	14.13	14.06	14.03	13.93	13.59
	55	51	14.60	14.50	14.43	14.40	14.30	13.90
	60	56	14.60	14.50	14.43	14.40	14.30	13.96
	63	59	14.60	14.50	14.43	14.40	14.30	14.00
68	64	14.60	14.50	14.43	14.40	14.30	14.06	
LMCN185HV 18,000	0	-0.4	10.70	10.55	10.45	10.40	10.25	9.80
	5	4.5	12.06	11.91	11.81	11.76	11.61	11.15
	10	9	13.41	13.26	13.16	13.11	12.96	12.51
	17	15	15.22	15.07	14.97	14.92	14.77	14.29
	20	19	15.90	15.75	15.65	15.60	15.45	14.92
	25	23	17.03	16.88	16.78	16.73	16.58	15.98
	30	28	18.01	17.86	17.76	17.71	17.56	17.03
	35	32	18.99	18.84	18.74	18.69	18.54	18.09
	40	36	19.87	19.72	19.62	19.57	19.42	18.97
	45	41	20.75	20.60	20.50	20.45	20.30	19.85
	47	43	21.10	20.95	20.85	20.80	20.65	20.20
	50	46	21.44	21.29	21.19	21.14	20.99	20.48
	55	51	22.01	21.86	21.75	21.70	21.55	20.95
	60	56	22.01	21.86	21.75	21.70	21.55	21.04
	63	59	22.01	21.86	21.75	21.70	21.55	21.10
68	64	22.01	21.86	21.75	21.70	21.55	21.20	

TC = Total Capacity (kBtu/h).

Nominal capacity as rated 0 ft. above sea level and a 0 ft. level difference between outdoor and indoor units. Corresponding refrigerant piping length is accordance with standard length of each outdoor unit.

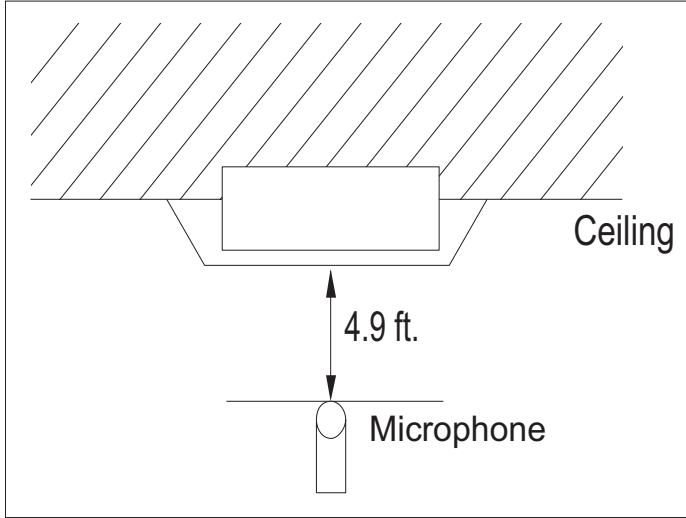
Nominal heating capacity rating obtained with air entering the indoor unit at 70°F dry bulb (DB) and 60°F wet bulb (WB), and outdoor ambient conditions of 47°F dry bulb (DB) and 43°F wet bulb (WB).

FOUR-WAY CEILING-CASSETTE INDOOR UNITS

MULTI F
MULTI F MAX

Acoustic Data

Figure 188: Sound Pressure Level Measurement Location.



- Measurement taken 4.9' away from the unit.
- Measurements taken with no attenuation and units operating at full load normal operating condition.
- Sound level will vary depending on a range of factors such as construction (acoustic absorption coefficient) of particular area in which the equipment is installed.
- Sound power levels are measured in dB(A)±3.
- Tested in anechoic chamber per ISO Standard 3745.

Table 76: Sound Pressure Levels (dB[A]).

Model No.	Sound Pressure Levels (dB[A]) (Cooling and Heating)		
	High Fan Speed	Medium Fan Speed	Low Fan Speed
LMCN077HV	31	27	24
LMCN097HV	36	33	30
LMCN125HV	38	35	32
LMCN185HV	38	37	34

Figure 189: LMCN077HV and LMCN097HV Sound Pressure Level Diagrams.

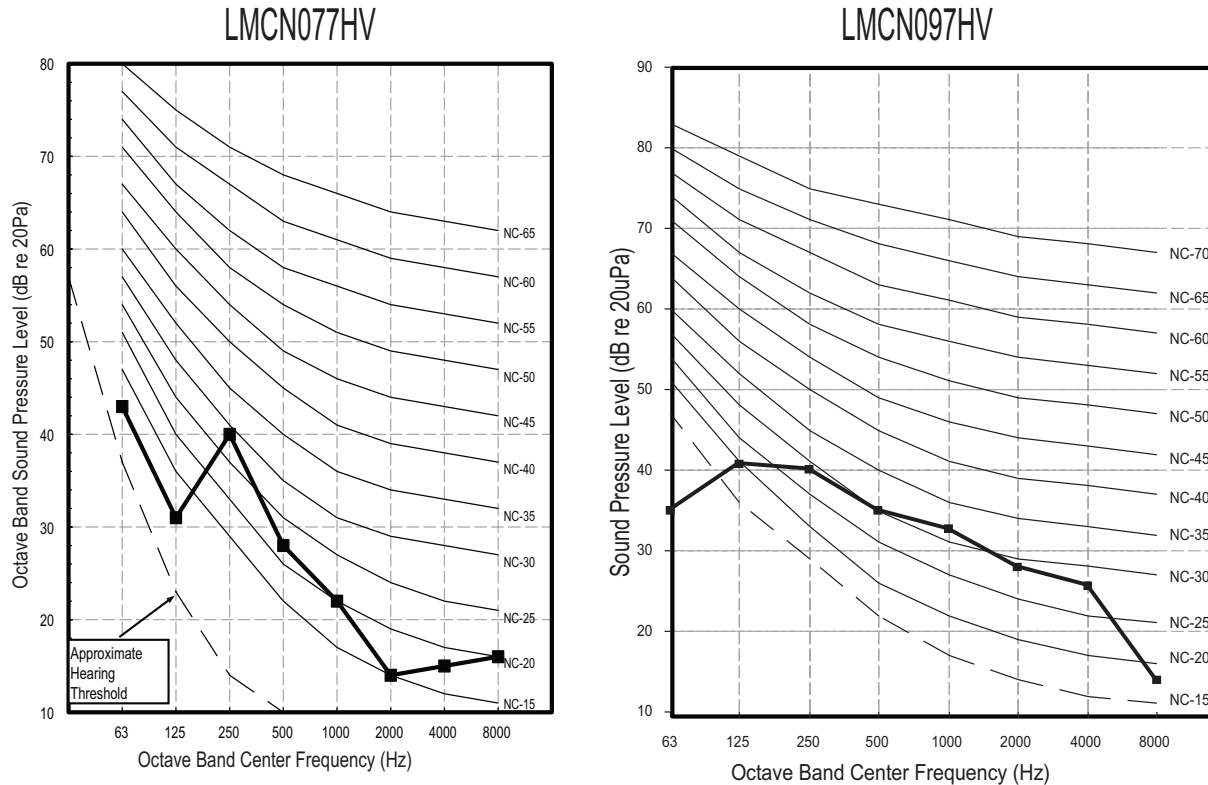
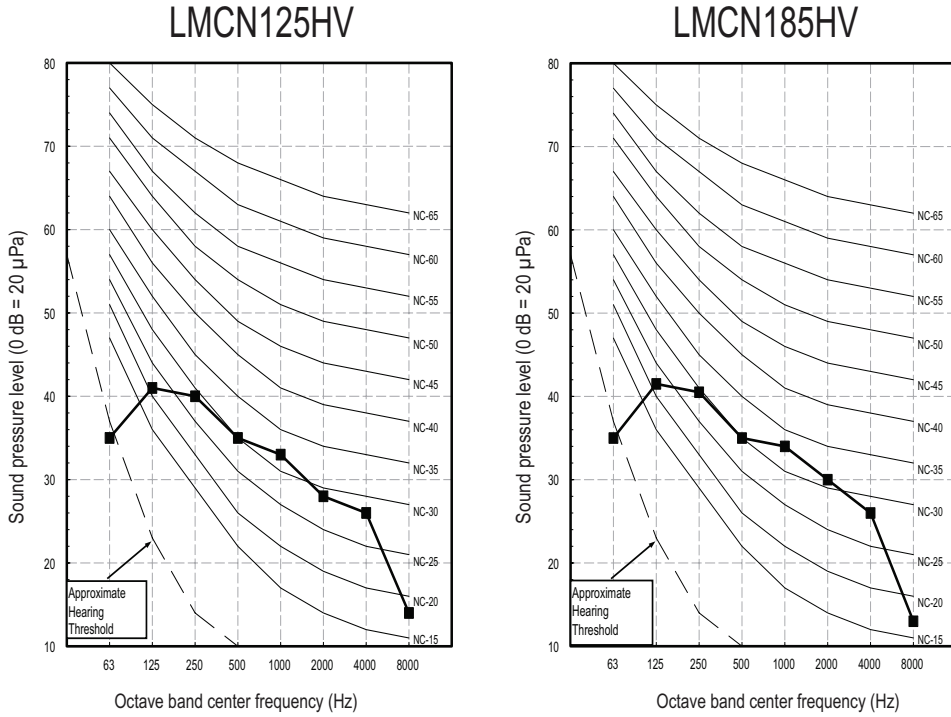


Figure 190: LMCN125HV and LMCN185HV Sound Pressure Level Diagrams.



FOUR-WAY CEILING-CASSETTE INDOOR UNITS

MULTI F
MULTI F MAX

Air Velocity and Temperature Distribution

Figure 191: LMCN077HV Air Velocity and Temperature Distribution Charts.

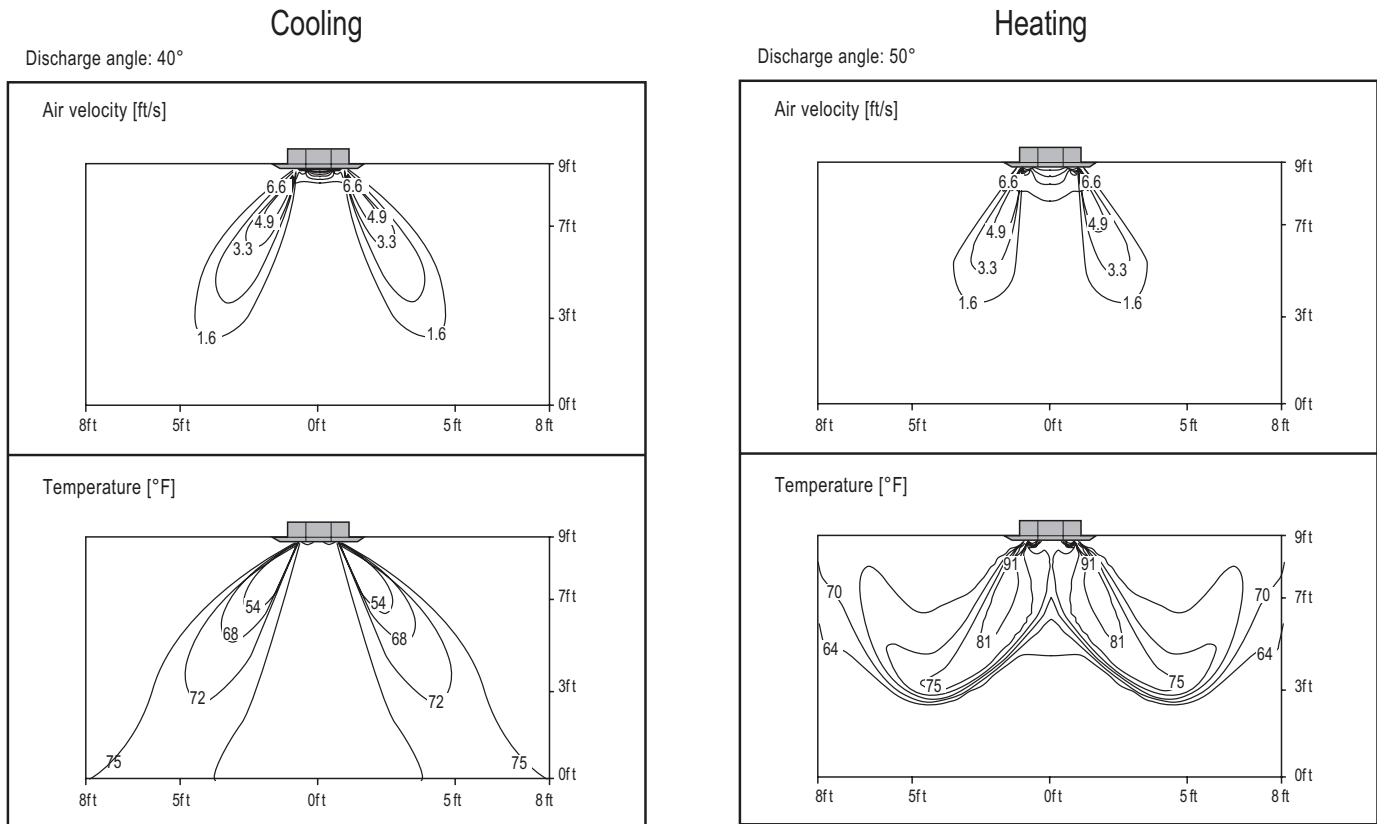


Figure 192: LMCN097HV Air Velocity and Temperature Distribution Charts.

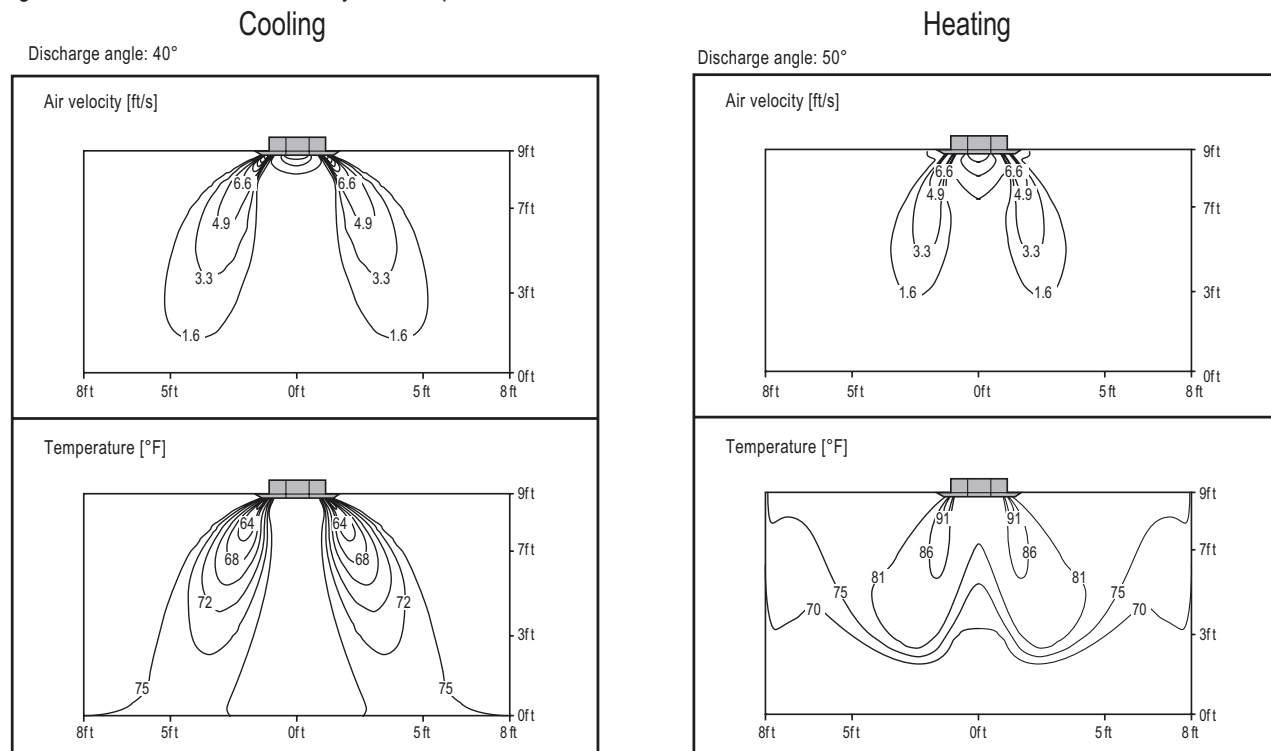


Figure 193: LMCN125HV Air Velocity and Temperature Distribution Charts.

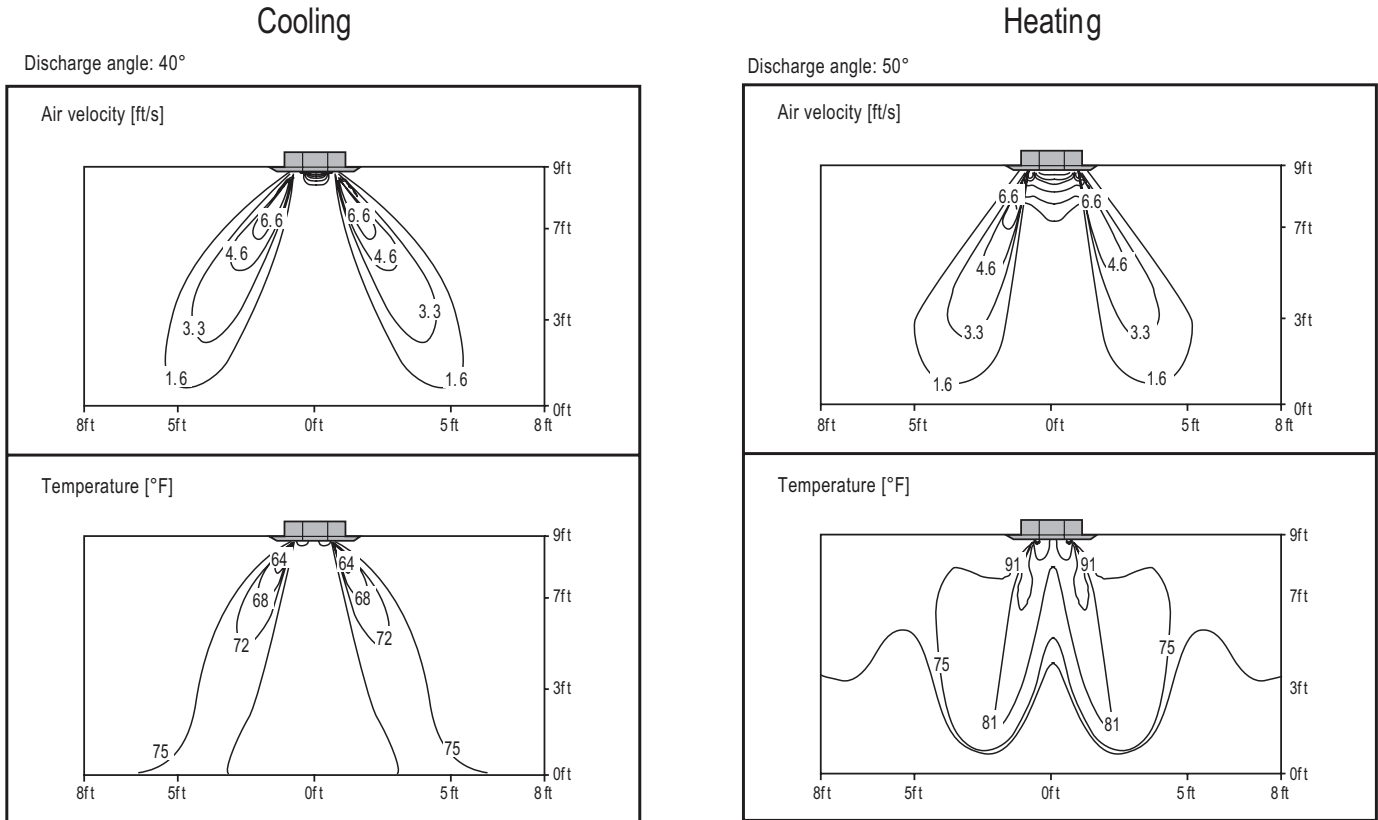
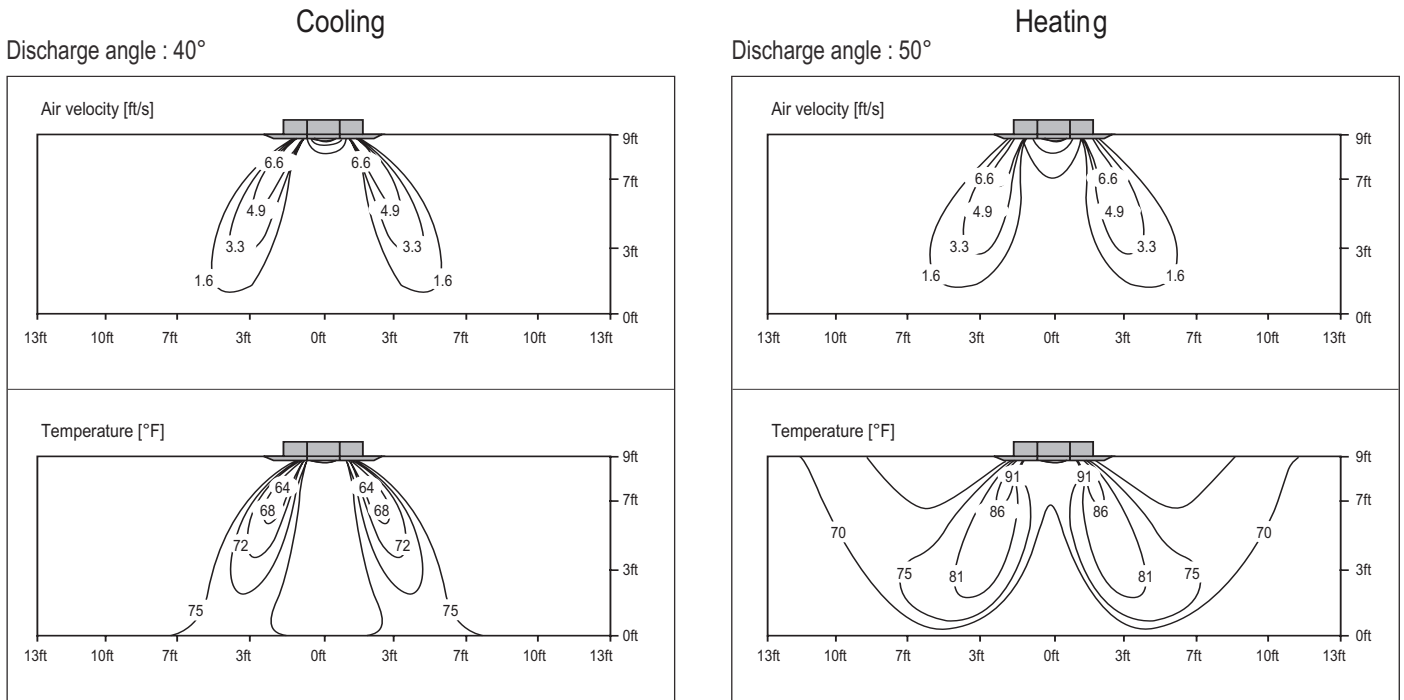


Figure 194: LMCN185HV Air Velocity and Temperature Distribution Charts.



FOUR-WAY CEILING-CASSETTE INDOOR UNITS

MULTI F
MULTI F MAX

Refrigerant Flow Diagram

Figure 195: Multi F Four-Way Ceiling-Cassette Indoor Unit Refrigerant Flow Diagram.

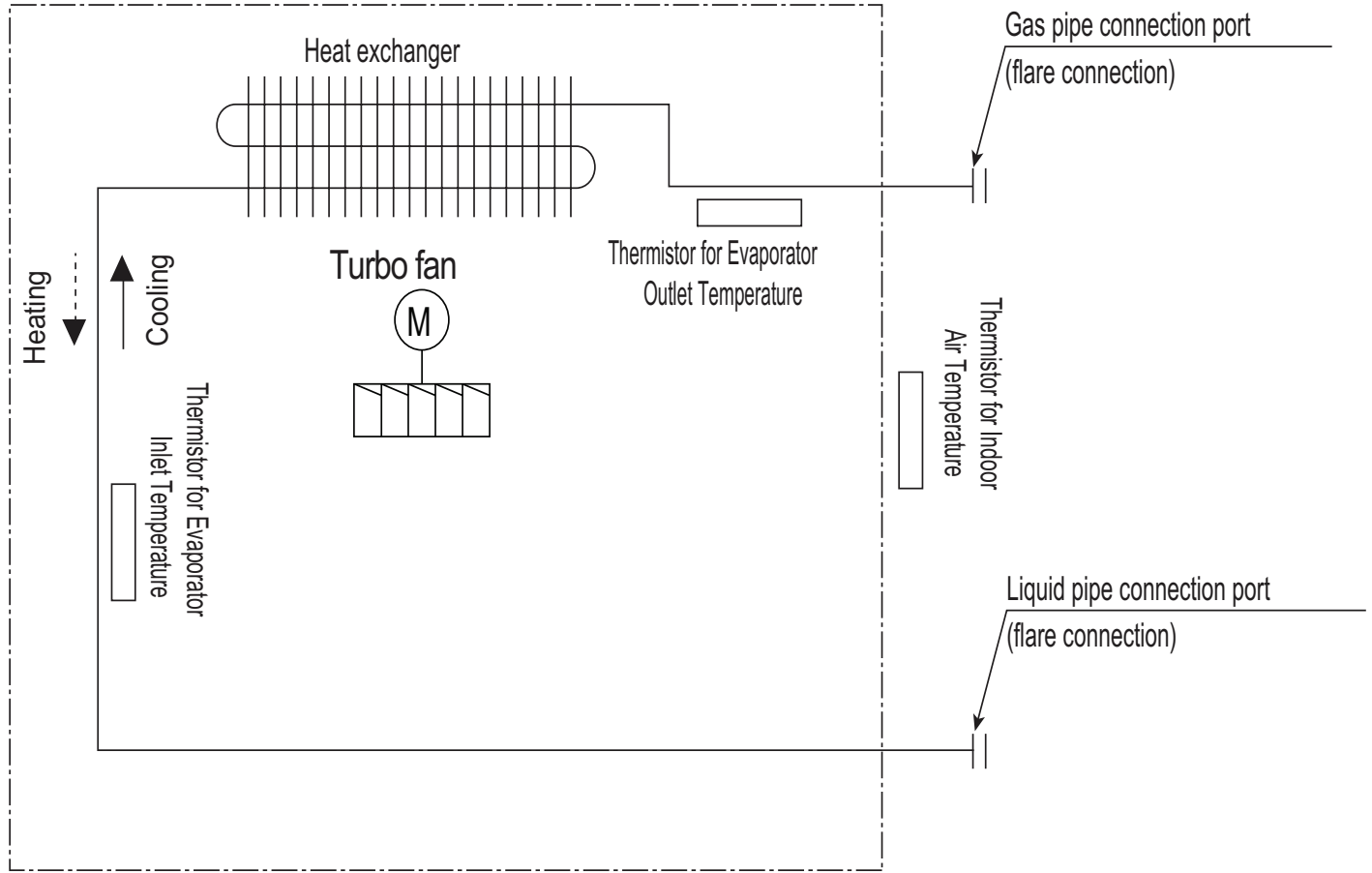


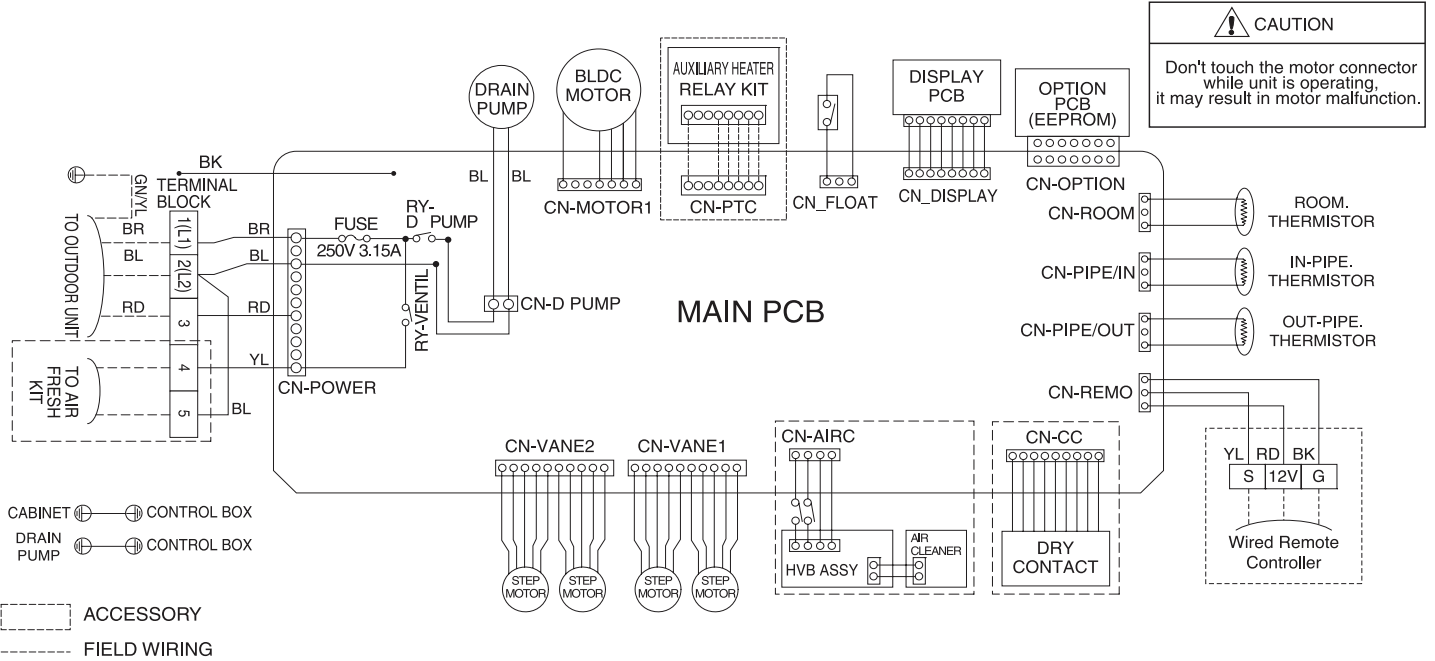
Table 77: Multi F Four-Way Ceiling-Cassette Indoor Unit Refrigerant Pipe Connection Port Diameters.

Model No.	Vapor (inch)	Liquid (inch)
LMCN077HV	Ø3/8	Ø1/4
LMCN097HV		
LMCN125HV		
LMCN185HV	Ø1/2	Ø1/4

Table 78: Multi F Four-Way Ceiling-Cassette Indoor Unit Thermistor Details.

Description (Based on Cooling Mode)	PCB Connector
Indoor Air Temperature Thermistor	CN-ROOM
Evaporator Inlet Temperature Thermistor	CN-PIPE/IN
Evaporator Outlet Temperature Thermistor	CN-PIPE/OUT

Figure 196: Multi F Four-Way Ceiling-Cassette Indoor Unit Wiring Diagram.



Four-Way Ceiling-Cassette

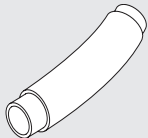
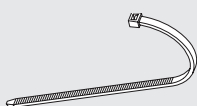
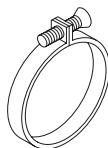
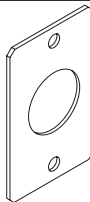
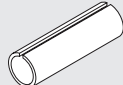

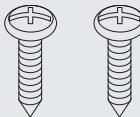
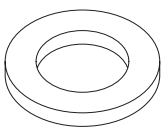

FOUR-WAY CEILING-CASSETTE INDOOR UNITS

MULTI F
MULTI F MAX

Factory Supplied Parts and Materials

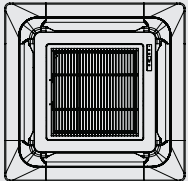
Factory Supplied Parts

Table 79: Parts Table.

Part	Quantity	Image	Part	Quantity	Image
Drain Hose	One (1)		Zip Ties	Four (4)	
Metal Clamp	Two (2)		Conduit Bracket	One (1)	
Insulation for Fittings	One (1) Set	 For Vapor Piping  For Liquid Piping	M4 Screws	Two (2)	
Washer for Hanging Bracket	Eight (8)		Wireless Handheld Controller with Holder (AKB73757604) ¹	One (1)	

¹Wireless Handheld Controller for the four-way ceiling cassette indoor units is also referenced by Model No. PQWRHQ0FDB.

Table 80: Required Accessory Table.

Part	Quantity	Image
Grille Kit (PTUQC)	One (1)	

Factory Supplied Materials

- Installation Guide (template)
- Owner's Manual
- Installation Manual

Required Tools

- Level
- Screwdriver
- Electric drill
- Hole core drill
- Flaring tool set
- Torque wrenches
- Hexagonal wrench
- Gas-leak detector
- Thermometer

⚠ WARNING

- Read all instructions before installing the product.
- Installation work must be performed by authorized personnel and in accordance with the national wiring standards and all local codes.

Selecting the Best Location

Do's

- Place the unit where air circulation will not be blocked.
- Place the unit where drainage can be obtained easily.
- Place the unit where noise prevention is taken into consideration.
- Ensure there is sufficient strength to bear the load of the indoor unit.
- Ensure there is sufficient maintenance space.
- Locate the indoor unit in a location that is level, and where it can be easily connected to the outdoor unit / branch distribution unit.

⚠ WARNING

Don'ts

- The unit should not be installed near a heat or steam source, or where considerable amounts of oil, iron powder, or flour are used.
- The unit should not be installed where sulfuric acid and flammable or corrosive gases are generated, vented into, or stored.
- Avoid installing the unit near high-frequency generators or near any equipment that generates an electromagnetic field (minimum 3-1/3 feet away).
- Do not install the unit near a doorway.

The unit may be damaged, may malfunction, and / or will not operate as designed if installed in any of the conditions listed.

Installing in a High or Dropped Ceiling

High or dropped ceilings, often found in commercial buildings and offices, may cause a wide temperature differentiation. To countermeasure:

- Change the indoor unit mode selection to allow for higher ceilings (see table).
- Install an air circulator.
- Set the air discharge outlet so that heated air flows in a downward direction.
- Use a dual door system to protect the building gate or exit.

Installing in an Area Exposed to Unconditioned Air

In some installation applications, areas (floors, walls) in some rooms may be exposed to unconditioned air (room may be above or next to an unheated garage or storeroom). To countermeasure:

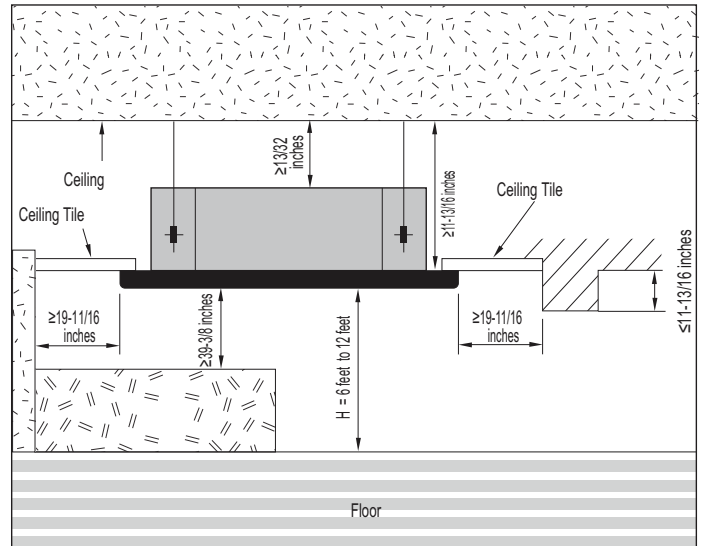
- Verify that carpet is or will be installed (carpet may increase the temperature by three (3) degrees).
- Add insulation between the floor joists.
- Install radiant heat or another type of heating system to the floor.

Installing in an Area with High Humidity Levels

If the environment is prone to humidity levels of 80% or more (near the ocean, lakes, etc.) or where steam could collect in the plenum:

- Install additional insulation to the indoor unit (glass wool insulation >13/32 inches thick).
- Install additional insulation to the refrigerant piping (insulation >13/16 inches thick).
- Seal all gaps between the indoor unit and the ceiling tiles (make the area air tight) so that humidity does not transfer from the plenum to the conditioned space. Also, add a ceiling grille for ventilation.

Figure 197: Indoor Unit Clearance Requirements.



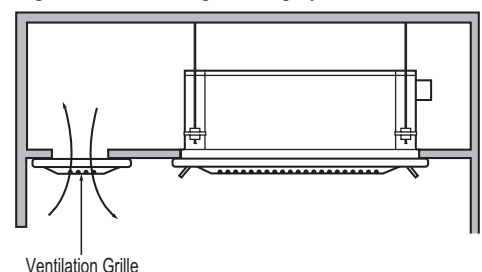
Note:

If the unit is installed near a body of water, certain components are at risk of being corroded. Appropriate anti-corrosion methods should be taken for the unit and all components.

Table 81: Indoor Unit High Ceiling Mode Selection Options.

Ceiling Height	Mode Selection
≤7-1/2 feet	Low Ceiling
7-1/2 feet to 8-7/8 feet	Standard
8-7/8 feet to 10-3/16 feet	High Ceiling
10-3/16 feet to 11-13/16 feet	Very High Ceiling

Figure 198: Installing in a Highly Humid Location.



FOUR-WAY CEILING-CASSETTE INDOOR UNITS

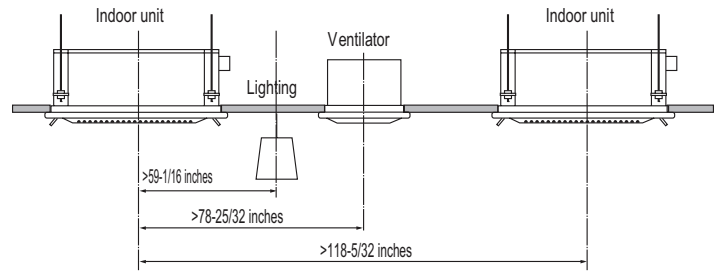
MULTI F
MULTI F MAX

Installation and Best Layout Practices

Installing Multiple Indoor Units in One Area

Ensure there is enough space between indoor units, lighting fixtures, and ventilation fans / systems.

Figure 199: Installing Multiple Indoor Units.

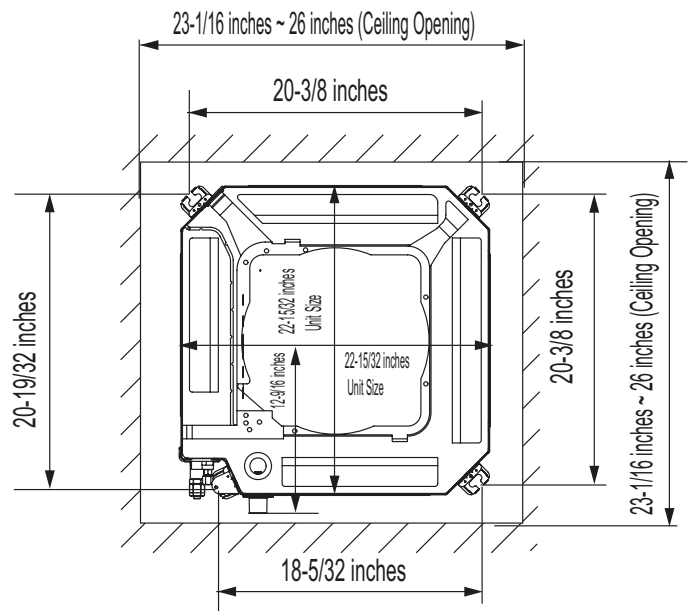


Preparing the Installation Area and Hanging the Indoor Unit Frame

Preparing the Installation Area

1. Installation guide (template) depicts the exact dimensions necessary for the ceiling opening.
2. Choose the location for the indoor unit, and then mark where the bolts, refrigerant piping, and drain hose should be. Suspension bolt angle should account for drain direction.
3. Drill holes for the bolts. Use either a W 3/8 inch or a M10 size bolt.

Figure 200: Ceiling Opening Dimensions and Bolt Locations.



Note:

For easier installation, attach the accessories (except for the decoration panel) before hanging the indoor unit.

Figure 201: Installing the Hanging Bolt in the Ceiling.

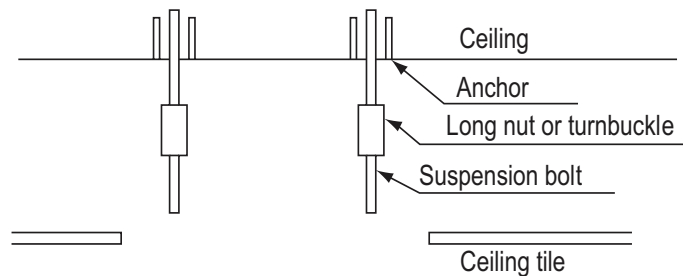
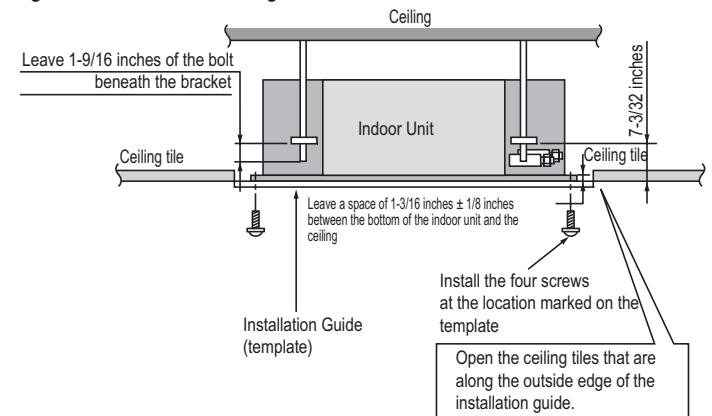


Figure 202: Installation Diagram.



For New Ceilings

1. Use a sunken insert, a sunken anchor, or any other field-supplied part to reinforce the ceiling so that it can bear the weight of the indoor unit. Use a temporary washer plate to more easily set up the unit suspension location.
2. Ceiling height is shown on the side of the installation guide (template). Adjust the height of the unit accordingly. Adjust the clearance before hanging the indoor unit.
3. Refer to the installation guide (template) for the dimensions to the ceiling opening. Match the center of the indoor unit (labeled) to the center indicated on the installation guide.
4. Align the installation guide (template) with the label attached to the unit (affixing the template to the unit if desired) to properly place the unit.
5. Remove the temporary washer plate and position the indoor unit hanger brackets on the bolts. Secure with nuts and washers on the top and bottom of the hanger brackets.
6. Ceiling-cassette indoor units are equipped with a built-in drain pump and float switch, therefore, the unit must be installed horizontally or condensate will drip out and cause product malfunction. Measure the unit at each corner to verify that it is level.
7. Remove the installation guide (template).

For Existing Ceilings

1. Use anchors when installing the indoor unit in an existing ceiling.
2. Ceiling height is shown on the side of the installation guide (template). Adjust the height of the unit accordingly. Adjust the clearance before hanging the indoor unit.
3. Remove the temporary washer plate and position the indoor unit hanger brackets on the bolts. Secure with nuts and washers on the top and bottom of the hanger brackets.
4. Ceiling-cassette indoor units are equipped with a built-in drain pump and float switch, therefore, the unit must be installed horizontally or condensate will drip out and cause product malfunction. Measure the unit at each corner to verify that it is level.
5. Remove the installation guide (template).

Installing the Drain System

- Drain piping must have downward gradient of at least 1/50 to 1/100; to prevent reverse flow, slope should not be straight up and down.
- Do not damage the drain port on the indoor unit when connecting the field-supplied drain piping.
- Drain piping specifications:
 - Indoor Unit Drain Connection: 1-1/4 inch outside diameter.
 - Field-Supplied Drain Piping: Polyvinyl chloride piping with 1-inch inside diameter and pipe fittings.

Checking the Drain Pump

The unit uses a drain pump to remove condensate. The pump must be tested before the system operates.

- Connect flexible drain hose to the field-installed drain piping; leave it as is until the test is complete.
- Pour water into the flexible drain hose and check for leaks.
- After power wiring installation is complete, operate the drain pump to see if it sounds and functions properly.
- After the test is complete, connect the flexible drain hose to the indoor unit drain port.

Figure 203: Hanging the Indoor Unit.

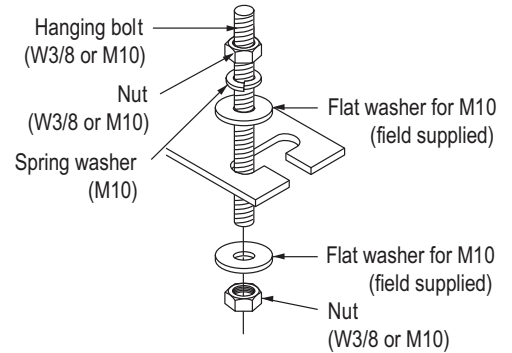


Figure 204: Indoor Unit Drain Piping.

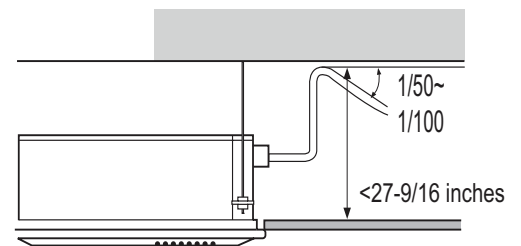
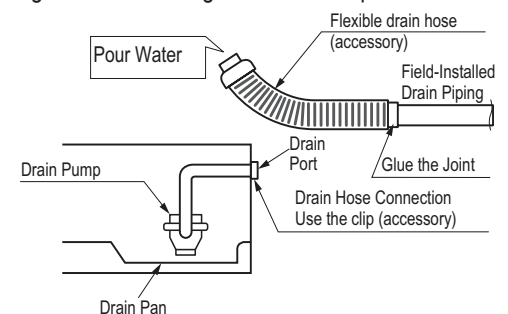


Figure 205: Checking the Drain Pump.



Insulating the Refrigerant and Drain Piping

Refrigerant Piping Insulation

Field-installed vapor and liquid refrigerant piping lines must be properly and completely covered in insulation (up to the indoor unit piping connections). Any exposed piping may generate condensate or will cause burns if touched. Insulation for this field-installed refrigerant piping must have a minimum heat resistance of 248°F.

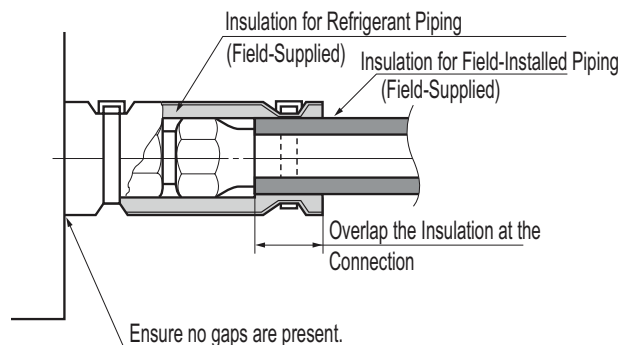
Drain Piping Insulation

Drain piping must have insulation a minimum of 7/32 inches thick.

Installing the Insulation

1. Overlap the insulation at the connection of the field-installed piping and the indoor unit piping. Tape together so that no gaps exist.
2. Secure insulation to the rear piping housing section with vinyl tape.
3. Bundle the piping and drain hose with tape where they meet at the back of the indoor unit frame. Position the drain hose at the bottom of the bundle (positioning the drain hose at the top of the bundle may cause the drain pan to overflow inside the indoor unit).

Figure 206: Insulating the Piping.



Power Wiring / Communications Cable Guidelines

- Follow manufacturer's circuit diagrams in the technical manuals.
- Confirm power source specifications.
- Confirm that the electrical capacity is sufficient.
- Starting current must be maintained ± 10 percent of the rated current marked on the outdoor unit name plate.
- Confirm cable thickness specifications.
- It is recommended that a circuit breaker is installed, especially if conditions could become wet or moist.
- Include a disconnect in the power wiring system, add an air gap contact separation of at least 1/8 inch in each active (phase) conductor.

⚠ WARNING

- Loose wiring may cause unit malfunction, or the terminal to overheat and catch fire.
- Terminal screws may become loose during transport. Properly tighten the terminal connections during installation.

A voltage drop may cause the following problems:

- Magnetic switch vibration, fuse breaks, or disturbance to the normal function of an overload protection device.
- Compressor will not receive the proper starting current.

Connecting the Power Wiring and Communications Cable

1. To access the terminal block, open the control box cover.
2. Insert the power wiring / communications cable from the outdoor unit or branch distribution unit (Multi F MAX systems only) through the sides of the indoor unit and control box. Pass the wiring through the designated access holes to prevent damage. To prevent electromagnetic interference and product malfunction, leave a space between the power wiring and communications cable outside of the indoor unit.
3. Connect each wire to its appropriate terminal on the indoor unit control board. Verify that the color and terminal numbers from the outdoor unit or branch distribution unit (Multi F MAX systems only) wiring match the color and terminal numbers on the indoor unit.
4. Neatly arrange power wiring / communications cable and secure with the appropriate cable restraint. When clamping, do not apply force to the wiring connections.
5. Firmly reattach the control box cover, do not catch the wiring in the electric box cover and make sure the cover firmly closes.
6. Fill in any gaps around the wiring access holes with sealant to prevent foreign particles from entering the indoor unit.

Figure 207: Power Wiring and Communications Cable Connection Access.

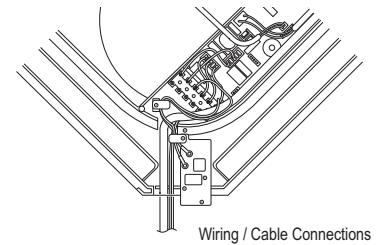
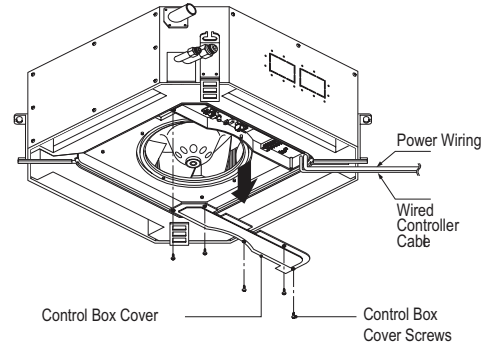
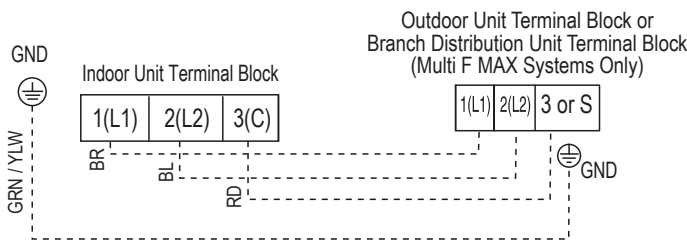


Figure 208: Simplified View of Indoor Unit to Outdoor Unit / Branch Distribution Unit Terminal Connections.



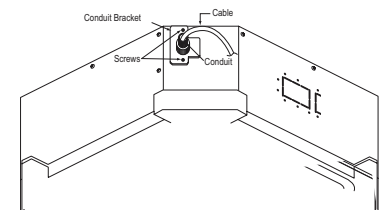
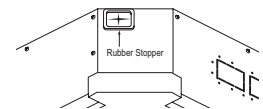
Using a Conduit

1. Remove the rubber stopper on the indoor unit. Pass the power wiring / communications cable through the conduit, the conduit mounting plate, and to / through the control panel of the indoor unit.
2. Tighten the conduit and the conduit mounting plate together.
3. Connect the power wiring / communications cable to the indoor unit terminal block.
4. Screw the conduit mounting plate to the indoor unit.

Note:

If the distance between the outdoor unit and indoor unit is greater than 131 feet, connect the power wiring and communications cable separately (i.e., a conduit cannot be used).

Figure 209: Using a Conduit.



FOUR-WAY CEILING-CASSETTE INDOOR UNITS

MULTI F
MULTI F MAX

Installation and Best Layout Practices

Controller Options

Four-way ceiling-concealed indoor units include a wireless handheld controller (AKB73757604)¹, but optional LG-supplied wired controllers are available (see Controls and Options overview on pages 9 to 12 in this manual's introduction section).

Wireless Handheld Controller

Figure 210:AKB73757604 Wireless Handheld Controller.

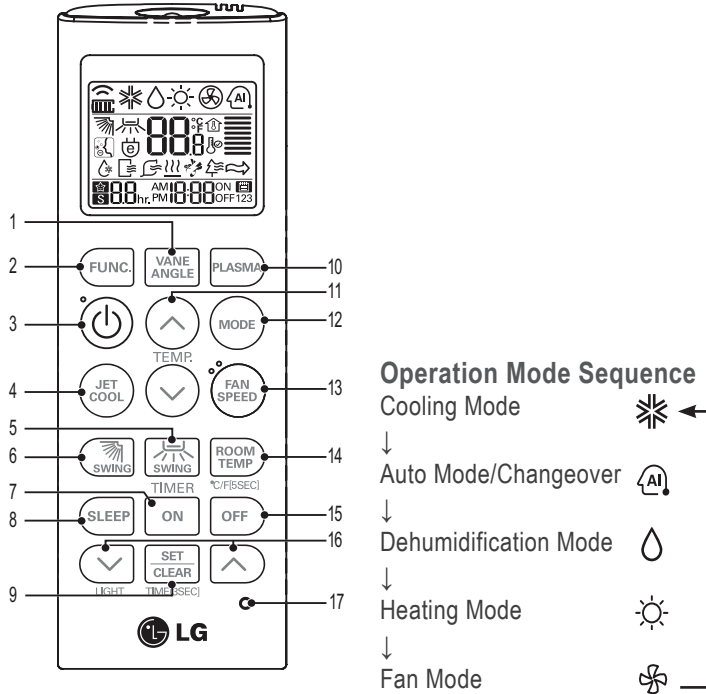


Table 82:AKB73757604¹ Wireless Handheld Controller Functions.²

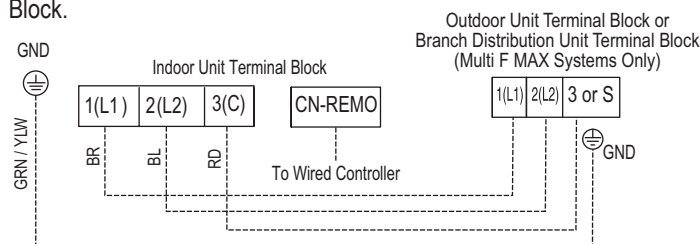
Button Label	Description
1	Vane Angle Button: Sets the angle to each vane.
2	Function Setting Button: Sets or clears auto clean, smart clean, electric heater, or individual vane angle control functions.
3	On / Off Button: Turns the power on/off.
4	Jet Cool: Sets the unit to super high fan speed when in cooling mode.
5	Left / Right Air Flow Button (optional): Sets the desired left / right (horizontal) air flow direction.
6	Up / Down Air flow Button: Stops or starts louver movement, and sets the desired air flow direction to up or down.
7	On Time Button: Sets the time when the operation begins.
8	Sleep Timer Button: Sets the sleep mode operation.
9	Set / Clear Button: Sets or cancels the timer, also sets the current time.
10	Plasma Button: Starts or stops plasma-purification functions.
11	Room Temperature Setting Button: Raises or lowers temperature setpoint in cooling and heating operation.
12	Operation mode selection button: Selects the operation mode.
13	Indoor Fan Speed Button: Changes the fan speed to one of four choices: low, medium, high, and chaos.
14	Room Temperature Check Button: Displays / checks the room temperature.
15	Off Timer button: Sets the time when the operation ends.
16	Time Setting (Up / Down) / Light Button: Sets the timer and adjusts the brightness of the LED.
17	Reset Button: Resets the remote controller.

¹Wireless Handheld Controller for the four-way ceiling cassette indoor units is also referenced by Model No. PQWRHQ0FDB.

²Depending on the indoor unit model, some functions may not be supported or displayed.

Wired Controller Connections

Figure 211:Wired Controller Connection on the Indoor Unit Terminal Block.



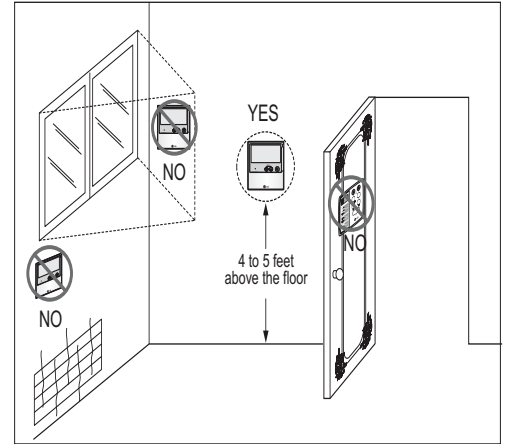
Wired Controller Placement

Wired controllers include a sensor to detect room temperature. To maintain comfort levels in the conditioned space, the wired controller must be installed in a location away from direct sunlight, high humidity, and where it could be directly exposed to cold air. Controller must be installed four (4) to five (5) feet above the floor where its LED display can be read easily, in an area with good air circulation, and where it can detect an average room temperature.

Do not install the wired controller near or in:

- Drafts or dead spots behind doors and in corners
- Hot or cold air from ducts
- Radiant heat from the sun or appliances
- Concealed pipes and chimneys
- An area where temperatures are uncontrolled, such as an outside wall

Figure 212: Proper Location for the Wired Controller.



Hanging the Wired Controller

1. The controller wiring / cable can be installed in one of three directions: top, back, or on the right side. If top or right side installation is desired, remove cable guide grooves on the controller, and then position wiring / cable on applicable side.
2. Choose and mark the area of installation, and then screw the wall plate into place (using the provided parts). Install the controller wall plate to fit the electrical box if one is present. Ensure that no gaps exist between the wall plate and the wall itself.
3. Arrange wiring / cables so as not to interfere with the controller circuitry. Position the wired controller on the wall plate. Snap into place by pressing the bottom part of the wired controller onto the wall plate. Make sure that no gaps exist between the wired controller and the wall plate on all sides.
4. To remove wired controller from the wall plate, insert a screwdriver into the two holes at the bottom. Twist screwdriver to release controller. Do not damage the controller components when removing.

Figure 213: Removing the Cable Guide Grooves.

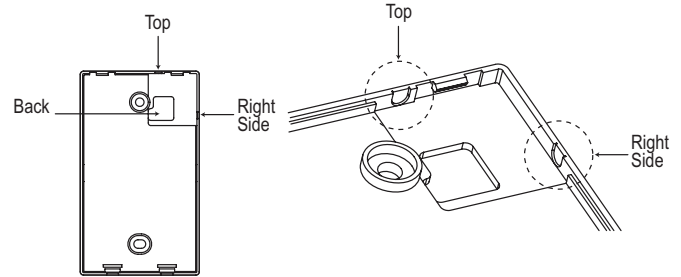


Figure 214: Attaching the Wall Plate.

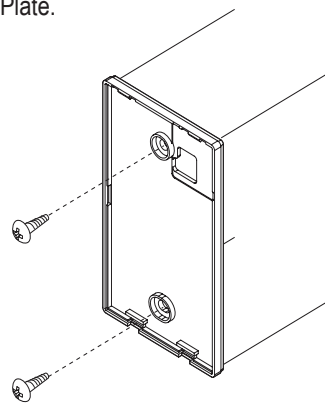
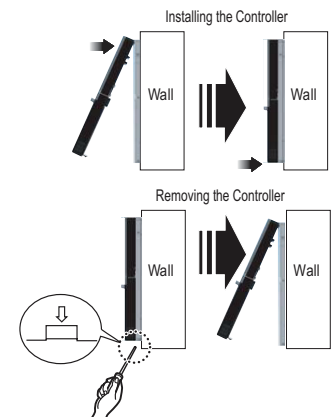


Figure 215: Installing / Removing the Controller.



Assigning the Thermistor for Temperature Detection

Each indoor unit includes a return air thermistor assigned to sense the temperature. If a wired controller is installed, there is a choice of sensing temperature with either the indoor unit return air thermistor or the thermistor in the wired controller. It is also an option to set both thermistors to sense temperature so that indoor unit bases its operation on the first thermistor to reach the designated temperature differential. For applicable indoor units, an optional Remote Temperature Sensor can be used in lieu of the return air thermistor—either alone or in conjunction with a wired controller thermistor as previously described.

FOUR-WAY CEILING-CASSETTE INDOOR UNITS

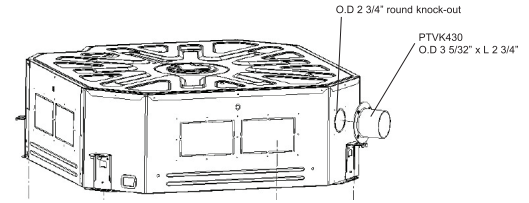
Installation and Best Layout Practices

MULTI F
MULTI F MAX

PTVK430 Ventilation Kit

PTVK430 Ventilation Kit includes a flange for field-supplied ventilation pipe connection. Easily connects at the four-way ceiling-cassette three (3) inch fresh air knockout hole.

Figure 216: PTVK430 Ventilation Kit.



Finalizing Indoor Unit Installation— Installing the Decoration Panel

Note:

Decoration panel must be installed properly; cool air will leak from any gaps found between the indoor unit frame and the decoration panel, which will cause condensation to generate.

1. Remove the packaging, take out air inlet grille from the front panel (1A), and then remove the corner covers of the panel (1B).
2. Attach the panel to the indoor frame by inserting the hooks as shown (2).
3. Attach two screws on diagonal corners of each panel, but do not tighten completely (3). Screws to attach the panel to the indoor unit frame are factory-provided and can be found in the shipping box.
4. Verify the panel is aligned with the ceiling. Adjust the height by using the hanging bolts as shown (4).
5. Attach the corner covers (5).
6. Unscrew the control panel cover (6).
7. Connect the one display connector (CN-DISP) and the two vane control connectors (CN-VANE1, CN-VANE2) of the front panel to the indoor unit PCB (7).
8. Close the control box cover. Attach the link on the front panel as shown (8). The link is supplied in the front panel shipping package.
9. Attach the other side of the link on the filter guide of the air inlet grille, then install the filter and the air inlet grille on the front panel (9).

Figure 217: Installing the Decoration Panel.

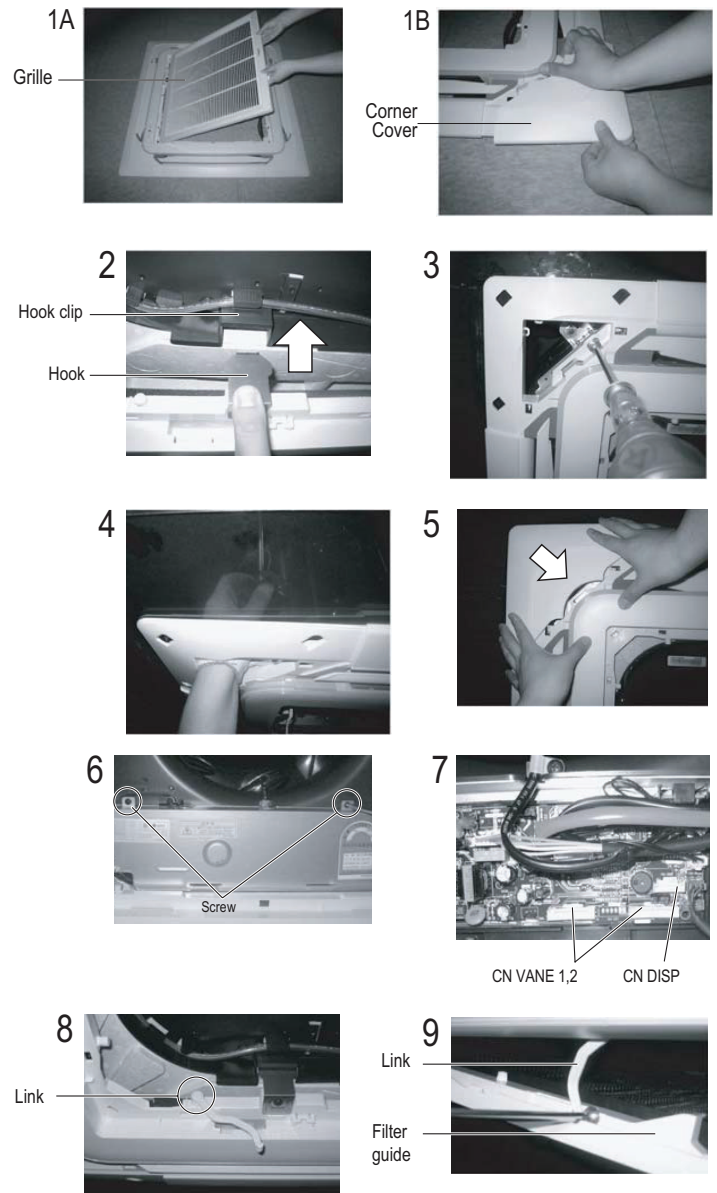
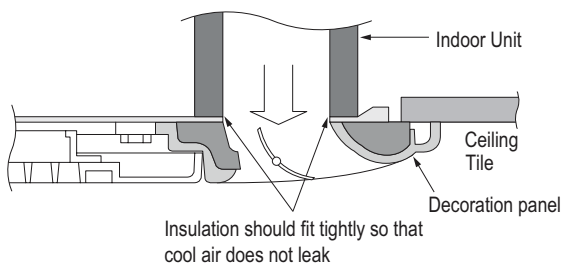


Figure 218: Ensure that no gaps are present between the indoor unit frame and the decoration panel.



VERTICAL-HORIZONTAL AIR HANDLING INDOOR UNIT DATA

“Mechanical Specifications” on page 154

“General Data / Specifications” on page 155

“Dimensions” on page 156

“Cooling Capacity Table” on page 157

“Heating Capacity Table” on page 158

“External Static Pressure” on page 159

“Acoustic Data” on page 160

“Refrigerant Flow Diagram” on page 161

“Wiring Diagram” on page 162

“Factory Supplied Parts and Materials” on page 164

“Installation and Best Layout Practices” on page 165

VERTICAL-HORIZONTAL INDOOR UNITS

Mechanical Specifications and Features

MULTI F
MULTI F MAX

Vertical-Horizontal Air Handling Indoor Unit

General

All LG indoor units are factory assembled, wired, piped, and provided with a control circuit board, fan, and motor. Vertical-Horizontal Air Handling units are designed for high-speed air volume against an external static pressure up to 1.00"WG. Supply air opening is flanged to accept field-installed ductwork that cannot exceed the external static pressure limit of the unit.

Coil

Indoor unit coils are factory built and are comprised of aluminum fins mechanically bonded to copper tubing. Each unit has a minimum of two rows of coils, which are pressure tested at the factory. Each unit is provided with a factory installed condensate drain pan below the coil.

Refrigerant System

System is designed for use with R410A refrigerant. The refrigeration circuit is pressure-tested at the factory and shipped with a holding charge of helium gas. Refrigerant pipe connections are 45° flare, and all refrigerant lines from the outdoor unit to the indoor units must be field insulated.

Electrical

Each indoor unit is designed to operate using 208–230/60/1 power with voltage variances of $\pm 10\%$.

Casing

The casing is designed to mount fully concealed behind a wall or above a finished ceiling. Casing is manufactured of 22-gauge pre-coated metal and finished with a high-gloss baked enamel finish. Cold surfaces of the unit are covered internally with 1/2-inch polystyrene fiber insulation; inside surface of the pan assembly door access panel is treated with 1/2-inch polystyrene fiber insulation, encapsulated on both sides. The access panel is sealed along the edges with reinforced foil-faced covering, all access panels also have gasket seals to minimize air leaks.

The vertical-horizontal air handling unit can operate in the vertical (upflow) configuration or horizontal (left) end discharge. Supply air is drawn from the top, and there is a dedicated bottom vertical return. Unit is also designed to accept an internal, optional LG electrical strip heater.

Fan Assembly and Control

The units have an integral fan assembly consisting of galvanized

steel housing and a forward curve fan wheel. The fan motor is a brushless digitally controlled (BLDC) motor with permanently lubricated and sealed ball bearings. The fan / motor assembly is mounted on vibration-attenuating rubber grommets. Fan speed is controlled using a microprocessor-based direct digital control algorithm. The indoor fan has Low, Med, High, and Auto settings for Cooling mode; and has Low, Med, High, and Auto settings for Heating mode. Each of the settings can be field-adjusted from the factory setting (RPM / ESP). The Auto setting adjusts the fan speed to most effectively achieve setpoint.

Filter Assembly

The unit includes a filter rack that can accept a field-supplied 16" x 20" x 1" filter cartridge. The filter rack has a guide to assist in centering the filters, and can be accessed from the front.

Microprocessor Control

The indoor unit is provided with an integrated control panel to communicate with the outdoor unit. All unit operation parameters are stored in non-volatile memory resident on the unit microprocessor. The microprocessor controls space temperature through using the value provided by temperature sensors within the indoor unit. A field-supplied communication cable must be installed to connect the indoor unit(s) to the outdoor unit.

Controls

The indoor unit is supplied with an LG wired controller. Communication between the indoor units and the outdoor unit is accomplished through 18 AWG, four-core, stranded and shielded power / communication cable.

Condensate

The unit is designed for gravity draining of condensate.

Figure 219: Multi F Vertical-Horizontal Air Handling Indoor Unit.



Features

- Inverter (Variable speed fan)
- Control lock function
- Auto operation
- Auto restart operation
- Dehumidifying function
- Two thermistor control
- Group control
- External static pressure control
- Self-diagnostics function
- Wired thermostat included

Table 83: Multi F Vertical-Horizontal Air Handling Indoor Unit General Data.

Model Name	LMVN240HV	LMVN360HV
Nominal Cooling Capacity (Btu/h) ¹	24,000	36,000
Nominal Heating Capacity (Btu/h) ¹	27,000	40,000
<i>Operating Range</i>		
Cooling (°F WB)	57-77	57-77
Heating (°F DB)	59-81	59-81
<i>Fan</i>		
Type	Sircocco	Sircocco
Motor Output (W) x Qty.	96 x 1	182 x 1
Motor/Drive	Brushless Digitally Controlled / Direct	Brushless Digitally Controlled / Direct
Airflow Rate CFM (H/M/L) at 0.5"WG ESP	710 / 640 / 480	990 / 880 / 800
Maximum External Static Pressure (in. WG)	1.00	1.00
<i>Unit Data</i>		
Refrigerant Type ²	R410A	R410A
Refrigerant Control	EEV	EEV
Power Supply V, Ø, Hz ³	208-230, 1, 60	208-230, 1, 60
Rated Amps (A)	0.59	1.12
Sound Pressure Level ±3 dB(A) (H/M/L) ⁴ at 0.3"WG ESP	43 / 42 / 41	45 / 44 / 43
Dimensions (W x H x D, in.)	18 x 48-21/32 x 21-1/4	18 x 48-21/32 x 21-1/4
Net Weight (lbs.)	117	121
Shipping Weight (lbs.)	130	135
Power Wiring / Communications Cable (No. x AWG) ⁵	4 x 18	4 x 18
Heat Exchanger (Row x Column x Fin / inch) x Number	(2 x 24 x 18) x 2	(3 x 24 x 18) x 2
<i>Piping</i>		
Liquid (in.)	1/4	3/8
Vapor (in.)	1/2	5/8
Primary Drain I.D. (in.)	3/4 FPT	3/4 FPT
Secondary Drain I.D. (in.)	3/4 FPT	3/4 FPT

¹Nominal capacity is rated 0 ft. above sea level with corresponding refrigerant piping length in accordance with standard length of each outdoor unit and a 0 ft. level difference between outdoor and indoor units. All capacities are net with a combination ratio between 95 – 105%.

Nominal cooling capacity rating obtained with air entering the indoor unit at 80°F dry bulb (DB) and 67°F wet bulb (WB) and outdoor ambient conditions of 95°F dry bulb (DB) and 75°F wet bulb (WB).
Nominal heating capacity rating obtained with air entering the indoor unit at 70°F dry bulb (DB) and 60°F wet bulb (WB) and outdoor ambient conditions of 47°F dry bulb (DB) and 43°F wet bulb (WB).

²This unit comes with a dry helium charge.

³Acceptable operating voltage: 187V-253V.

⁴Sound pressure levels are tested in an anechoic chamber under ISO Standard 3745 and are the same in both cooling and heating mode. These values can increase due to ambient conditions during operation.

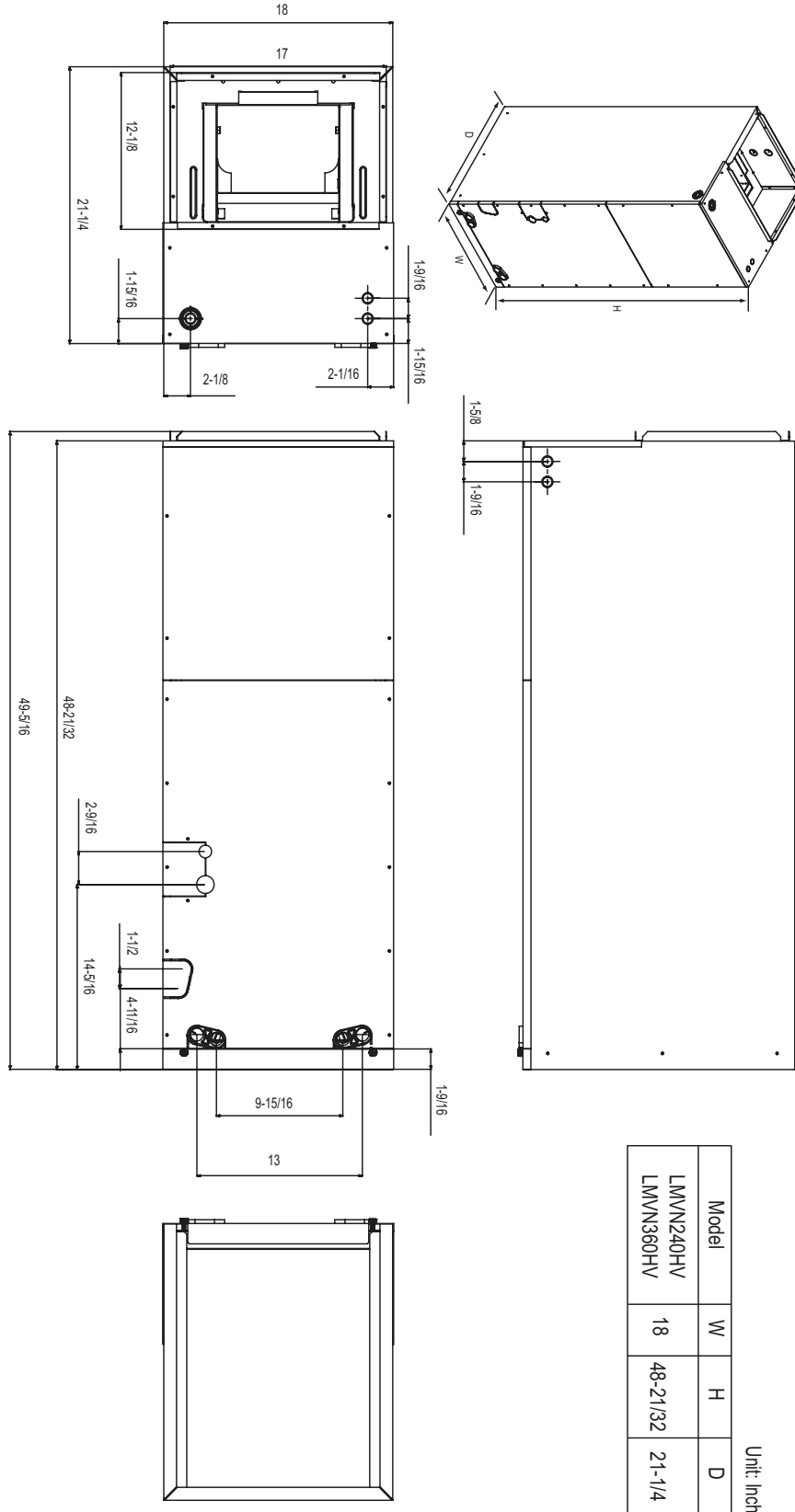
⁵All power wiring / communication cables to be minimum 18 AWG, 4-conductor, stranded, shielded, and must comply with applicable local and national codes.

VERTICAL-HORIZONTAL INDOOR UNITS

Dimensions

MULTI F
MULTI F MAX

Figure 220: LMVN240HV and LMVN360HV Dimensions.



Multi F and Multi F MAX Indoor Unit Engineering Manual



Table 84: Multi F Vertical-Horizontal Air Handling Indoor Units Cooling Capacity Table.

Model No. / Nominal Capacity of Indoor Unit (Btu/h)	Outdoor Air Temp. (°F DB)	Indoor Air Temp. °F DB / °F WB											
		68 / 57		73 / 61		77 / 64		80 / 67		86 / 72		90 / 75	
		TC	SHC	TC	SHC	TC	SHC	TC	SHC	TC	SHC	TC	SHC
LMVN240HV 24,000	14	23.53	17.89	24.99	18.90	26.45	18.30	27.50	18.69	29.37	18.84	30.83	19.20
	20	23.51	18.03	24.97	19.05	26.43	18.44	27.48	18.83	29.35	18.99	30.81	19.35
	25	23.49	18.17	24.95	19.20	26.41	18.59	27.46	18.98	29.33	19.14	30.79	19.50
	30	23.47	18.31	24.93	19.34	26.39	18.73	27.44	19.12	29.30	19.28	30.76	19.65
	35	23.46	18.45	24.91	19.49	26.37	18.87	27.42	19.27	29.28	19.43	30.74	19.80
	40	23.44	18.59	24.89	19.64	26.35	19.01	27.40	19.41	29.26	19.58	30.72	19.95
	45	23.42	18.73	24.87	19.78	26.33	19.15	27.38	19.56	29.24	19.72	30.69	20.10
	50	23.40	18.87	24.85	19.93	26.31	19.30	27.36	19.70	29.21	19.87	30.67	20.24
	55	23.38	19.00	24.84	20.07	26.29	19.44	27.34	19.85	29.19	20.01	30.64	20.39
	60	23.37	19.14	24.82	20.22	26.27	19.58	27.32	19.99	29.17	20.16	30.62	20.54
	65	23.35	19.28	24.80	20.37	26.25	19.72	27.29	20.13	29.15	20.30	30.60	20.69
	70	23.33	19.42	24.78	20.51	26.23	19.86	27.27	20.28	29.13	20.45	30.57	20.84
	75	22.77	19.10	24.21	20.20	25.66	19.58	26.70	20.01	28.55	20.20	29.99	20.60
	80	22.21	18.77	23.65	19.88	25.09	19.30	26.13	19.73	27.97	19.95	29.42	20.36
	85	21.65	18.43	23.09	19.55	24.53	18.99	25.57	19.44	27.40	19.68	28.84	20.10
	90	21.09	18.08	22.53	19.21	23.96	18.69	25.00	19.14	26.83	19.40	28.27	19.84
	95	20.49	17.89	21.92	19.03	23.35	18.55	24.00	18.72	26.20	19.30	27.63	19.75
	100	19.99	17.41	21.42	18.55	22.85	18.10	23.69	18.43	25.70	18.88	27.13	19.35
105	19.49	16.93	20.92	18.07	22.35	17.66	23.38	18.14	25.20	18.47	26.63	18.94	
110	18.99	16.35	20.42	17.49	21.85	17.12	22.88	17.60	24.70	17.94	26.13	18.42	
115	18.49	15.86	19.92	17.00	21.35	16.66	22.38	17.15	24.20	17.51	25.63	18.00	
118	18.19	15.75	19.62	16.89	21.05	16.58	22.08	17.07	23.90	17.46	25.33	17.96	
122	18.10	15.71	19.52	16.86	20.95	16.55	21.98	17.05	23.81	17.44	25.23	17.94	
LMVN360HV 36,000	14	35.29	26.84	37.48	28.35	39.67	27.45	41.26	28.03	44.06	28.26	46.25	28.80
	20	35.26	27.05	37.45	28.57	39.64	27.66	41.23	28.25	44.02	28.49	46.21	29.02
	25	35.24	27.26	37.43	28.79	39.61	27.88	41.19	28.47	43.99	28.71	46.18	29.25
	30	35.21	27.47	37.40	29.01	39.58	28.09	41.16	28.68	43.96	28.93	46.14	29.47
	35	35.18	27.67	37.37	29.23	39.55	28.31	41.13	28.90	43.92	29.15	46.11	29.70
	40	35.16	27.88	37.34	29.45	39.52	28.52	41.10	29.12	43.89	29.37	46.07	29.92
	45	35.13	28.09	37.31	29.67	39.49	28.73	41.07	29.34	43.86	29.58	46.04	30.14
	50	35.10	28.30	37.28	29.89	39.46	28.94	41.04	29.55	43.82	29.80	46.00	30.37
	55	35.08	28.51	37.25	30.11	39.43	29.16	41.01	29.77	43.79	30.02	45.97	30.59
	60	35.05	28.71	37.23	30.33	39.40	29.37	40.97	29.99	43.76	30.24	45.93	30.81
	65	35.02	28.92	37.20	30.55	39.37	29.58	40.94	30.20	43.72	30.46	45.90	31.03
	70	34.99	29.13	37.17	30.77	39.34	29.79	40.91	30.42	43.69	30.67	45.86	31.26
	75	34.15	28.65	36.32	30.30	38.49	29.37	40.05	30.01	42.82	30.30	44.99	30.90
	80	33.31	28.16	35.47	29.82	37.64	28.94	39.20	29.60	41.96	29.92	44.12	30.54
	85	32.48	27.64	34.63	29.32	36.79	28.49	38.35	29.16	41.10	29.52	43.26	30.15
	90	31.64	27.12	33.79	28.81	35.94	28.03	37.50	28.71	40.25	29.10	42.40	29.76
	95	30.74	26.84	32.88	28.55	35.02	27.82	36.00	28.08	39.30	28.95	41.44	29.63
	100	29.99	26.12	32.13	27.83	34.27	27.15	35.53	27.65	38.55	28.32	40.69	29.02
105	29.24	25.40	31.38	27.11	33.52	26.49	35.07	27.21	37.80	27.70	39.94	28.41	
110	28.49	24.53	30.63	26.23	32.77	25.67	34.32	26.40	37.05	26.92	39.20	27.64	
115	27.74	23.80	29.88	25.49	32.02	24.99	33.57	25.72	36.31	26.27	38.45	27.01	
118	27.29	23.62	29.43	25.34	31.57	24.87	33.12	25.61	35.86	26.18	38.00	26.93	
122	27.14	23.56	29.28	25.29	31.43	24.82	32.97	25.57	35.71	26.15	37.85	26.91	

TC = Total Capacity (kBtu/h).

SHC: Sensible Heat Capacity (kBtu/h).

Nominal capacity as rated 0 ft. above sea level and a 0 ft. level difference between outdoor and indoor units. Corresponding refrigerant piping length is accordance with standard length of each outdoor unit.

Nominal cooling capacity rating obtained with air entering the indoor unit at 80°F dry bulb (DB) and 67°F wet bulb (WB), and outdoor ambient conditions of 95°F dry bulb (DB) and 75°F wet bulb (WB).

The shaded table columns and rows indicate reference data. When operating at this temperature, these values can be different if the system is not running consistently.

Vertical-Horizontal Air Handling

VERTICAL-HORIZONTAL INDOOR UNITS

Heating Capacity Table

MULTI F
MULTI F MAX

Table 85: Multi F Vertical-Horizontal Air Handling Indoor Units Heating Capacity Table.

Model No. / Nominal Capacity of Indoor Unit (Btu/h)	Outdoor Air Temp.		Indoor Air Temp. °F DB					
	°F DB	°F WB	61	64	68	70	72	75
			TC	TC	TC	TC	TC	TC
LMVN240HV 24,000	0	-0.4	13.89	13.70	13.57	13.50	13.30	12.72
	5	4.5	15.65	15.46	15.33	15.26	15.07	14.48
	10	9	17.41	17.22	17.09	17.02	16.83	16.24
	17	15	19.76	19.57	19.43	19.37	19.17	18.55
	20	19	20.64	20.45	20.32	20.25	20.05	19.37
	25	23	22.11	21.91	21.78	21.72	21.52	20.74
	30	28	23.38	23.18	23.05	22.99	22.79	22.11
	35	32	24.65	24.46	24.33	24.26	24.07	23.48
	40	36	25.79	25.60	25.47	25.40	25.21	24.62
	45	41	26.93	26.74	26.61	26.54	26.35	25.76
	47	43	27.39	27.20	27.07	27.00	26.80	26.22
	50	46	27.83	27.64	27.51	27.44	27.24	26.58
	55	51	28.57	28.37	28.24	28.17	27.98	27.20
	60	56	28.57	28.37	28.24	28.17	27.98	27.32
	63	59	28.57	28.37	28.24	28.17	27.98	27.39
68	64	28.57	28.37	28.24	28.17	27.98	27.51	
LMVN360HV 36,000	0	-0.4	20.58	20.29	20.10	20.00	19.71	18.84
	5	4.5	23.19	22.90	22.71	22.61	22.32	21.45
	10	9	25.80	25.51	25.31	25.22	24.93	24.06
	17	15	29.28	28.99	28.79	28.70	28.41	27.48
	20	19	30.58	30.29	30.10	30.00	29.71	28.70
	25	23	32.75	32.46	32.27	32.17	31.88	30.72
	30	28	34.64	34.35	34.15	34.06	33.77	32.75
	35	32	36.52	36.23	36.04	35.94	35.65	34.78
	40	36	38.21	37.92	37.73	37.63	37.34	36.47
	45	41	39.90	39.61	39.42	39.32	39.03	38.16
	47	43	40.58	40.29	40.10	40.00	39.71	38.84
	50	46	41.23	40.94	40.75	40.65	40.36	39.38
	55	51	42.32	42.03	41.84	41.74	41.45	40.29
	60	56	42.32	42.03	41.84	41.74	41.45	40.47
	63	59	42.32	42.03	41.84	41.74	41.45	40.58
68	64	42.32	42.03	41.84	41.74	41.45	40.76	

TC = Total Capacity (kBtu/h).

Nominal capacity as rated 0 ft. above sea level and a 0 ft. level difference between outdoor and indoor units. Corresponding refrigerant piping length is accordance with standard length of each outdoor unit.

Nominal heating capacity rating obtained with air entering the indoor unit at 70°F dry bulb (DB) and 60°F wet bulb (WB), and outdoor ambient conditions of 47°F dry bulb (DB) and 43°F wet bulb (WB).

Table 86: Multi F Vertical-Horizontal Air Handling Unit External Static Pressure Setting Values Table.

Static Pressure (in. wg)			0.1	0.2	0.3	0.4	0.5	0.6	0.7	0.8	0.9	1.0
Model No. / Nominal Capacity of Indoor Unit (Btu/h)	Airflow Rate / CFM		Setting Value at (in. wg) ¹									
	LMVN240HV 24,000	High	710	56	67	74	78	87	94	98	98 ²	98 ²
Mid		640	53	65	70	75	85	91	96	96 ²	96 ²	96 ²
Low		480	53	55	64	70	79	84	92	92 ²	92 ²	92 ²
LMVN360HV 36,000	High	990	80	85	90	95	100	103	103 ²	103 ²	103 ²	103 ²
	Mid	880	65	72	80	85	92	98	103	103 ²	103 ²	103 ²
	Low	800	65	69	77	82	90	96	101	101 ²	101 ²	101 ²

¹Unless otherwise noted, vertical-horizontal air handling units are UL listed up to 0.5 in. wg total static pressure, including coil, case, duct work pressure drop, air filter, and largest kW size heater. Internal static pressure includes coil and case only.

²Airflow rate (CFM) decreases by 3% per 0.1 in. wg.

³Maximum airflow rate is 400 CFM per ton. (For the 24,000 Btu/h unit, the maximum airflow rate is 2 x 400 = 800 CFM). If airflow is set at the maximum rate, the external static pressure value should be increased from high speed setting value to: From 24kBtu/h of capacity: 4; From 36kBtu/h of capacity: 5

⁴High static pressure is 0.5 in. wg (factory setting); low static pressure is 0.3 in. wg.

Note:

If external static pressure is not set correctly, the air conditioning system may not operate properly or may malfunction.

Table 87: Multi F Vertical-Horizontal Air Handling Unit Minimum Airflow by Heater Capacity.

Model No. / Nominal Capacity of Indoor Unit (Btu/h)	Heater Capacity (kW)			
	5	10	15	20
LMVN240HV (24,000)	480 CFM	480 CFM	Not Available	Not Available
LMVN360HV (36,000)	780 CFM	780 CFM	Not Available	Not Available

⚠ WARNING

Do not operate the air conditioning system using less than the minimum airflow. There is risk of fire or product damage.

Table 88: Electric Heater Static Pressure Drop.

Heater Capacity (kW)	Static Pressure Drop (in. wg)
0	0
5	-0.01
10	-0.02

Note:

- The external static pressure value must be reset if an electric heater is installed. For each 0.01 in. wg. increase in static pressure, the external static pressure should increase by 1.
- If the external static pressure is not set properly, the provided safety device will turn off the heater (according to airflow).

Table 89: Field-Supplied Air Filter Static Pressure Drop Factors.

Model No. / Nominal Capacity of Indoor Unit (Btu/h)	Airflow Rate / CFM		Static Pressure Drop (in. wg)
LMVN240HV (24,000)	High	710	-0.04
	Mid	640	-0.03
	Low	480	-0.03
LMVN360HV (36,000)	High	990	-0.07
	Mid	880	-0.05
	Low	800	-0.05

Note:

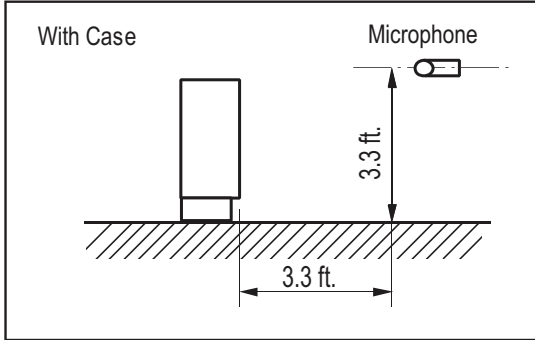
- The external static pressure value must be reset if an air filter is installed. For each 0.01 in. wg. increase in static pressure, the external static pressure should increase by 1.
- Factory tested with MERV 4 filter media. Fan speed set value when the unit is used with field-supplied filter media.

VERTICAL-HORIZONTAL INDOOR UNITS

Acoustic Data

MULTI F
MULTI F MAX

Figure 221: Sound Pressure Level Measurement Location.



- Measurement taken 3.3' away from the unit.
- Measurements taken with no attenuation and units operating at full load normal operating condition.
- Sound level will vary depending on a range of factors such as construction (acoustic absorption coefficient) of particular area in which the equipment is installed.
- Sound power levels are measured in dB(A)±3.
- Tested in anechoic chamber per ISO Standard 3745.

Table 90: Sound Pressure Levels (dB[A]).

Model No.	Sound Pressure Levels (dB[A]) (Cooling and Heating)		
	High Fan Speed	Medium Fan Speed	Low Fan Speed
LMVN240HV	43	42	41
LMVN360HV	45	44	43

Figure 222: Sound Pressure Level Diagrams.

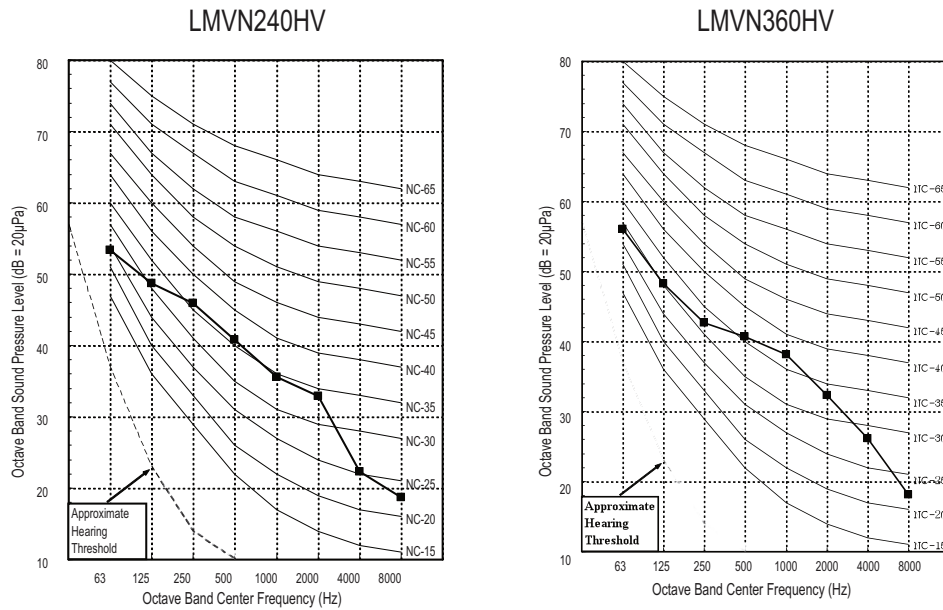


Figure 223: Multi F Vertical-Horizontal Air Handling Indoor Unit Refrigerant Flow Diagram.

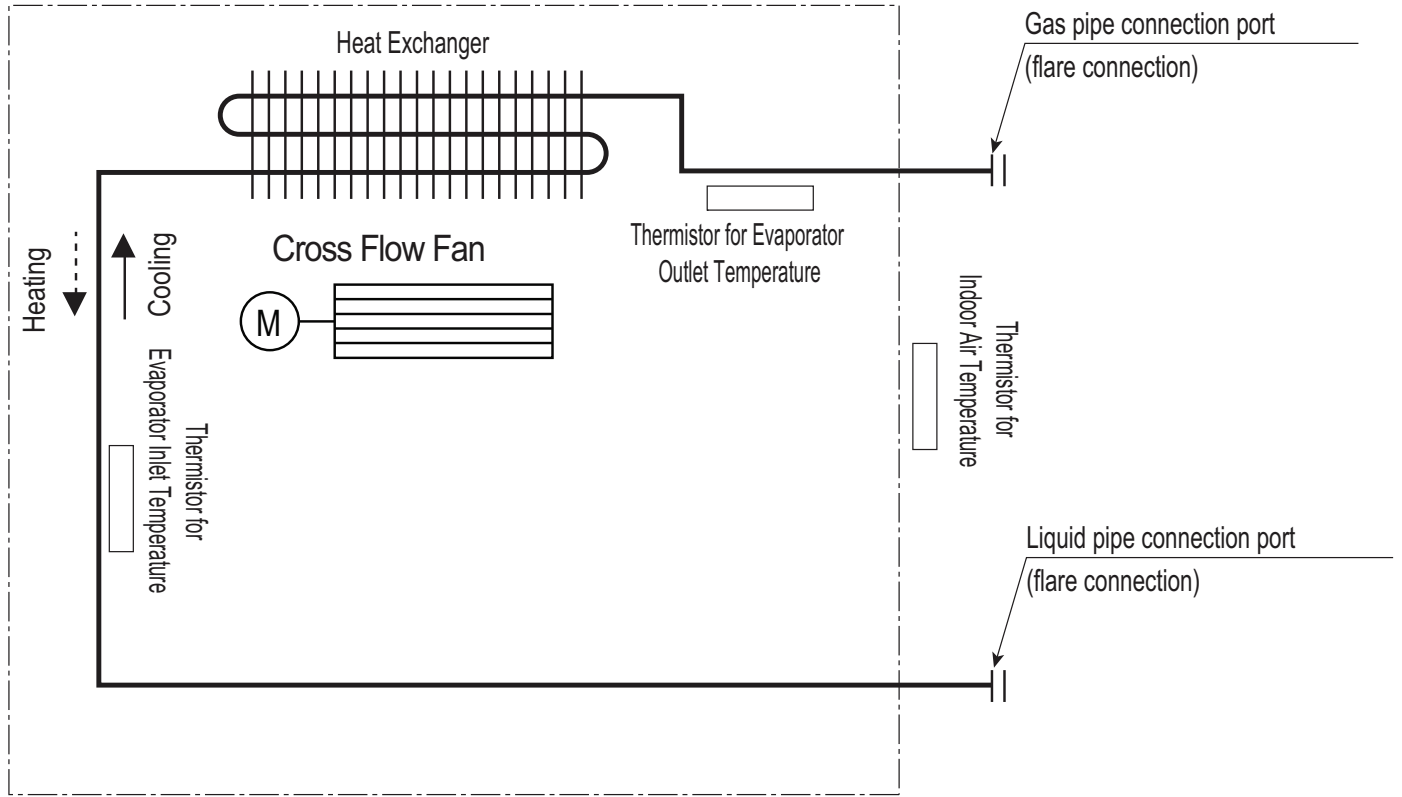


Table 91: Multi F Vertical-Horizontal Air Handling Indoor Unit Refrigerant Pipe Connection Port Diameters.

Model No.	Vapor (inch)	Liquid (inch)
LMVN240HV	1/2	1/4
LMVN360HV	5/8	3/8

Table 92: Multi F Vertical-Horizontal Air-Handling Indoor Unit Thermistor Details.

Description (Based on Cooling Mode)	PCB Connector
Indoor Air Temperature Thermistor	CN-ROOM
Evaporator Inlet Temperature Thermistor	CN-PIPE/IN
Evaporator Outlet Temperature Thermistor	CN-PIPE/OUT

VERTICAL-HORIZONTAL INDOOR UNITS

Wiring Diagram

MULTI F
MULTI F MAX

Figure 224: Multi F Vertical-Horizontal Air-Handling Indoor Unit Wiring Diagram.

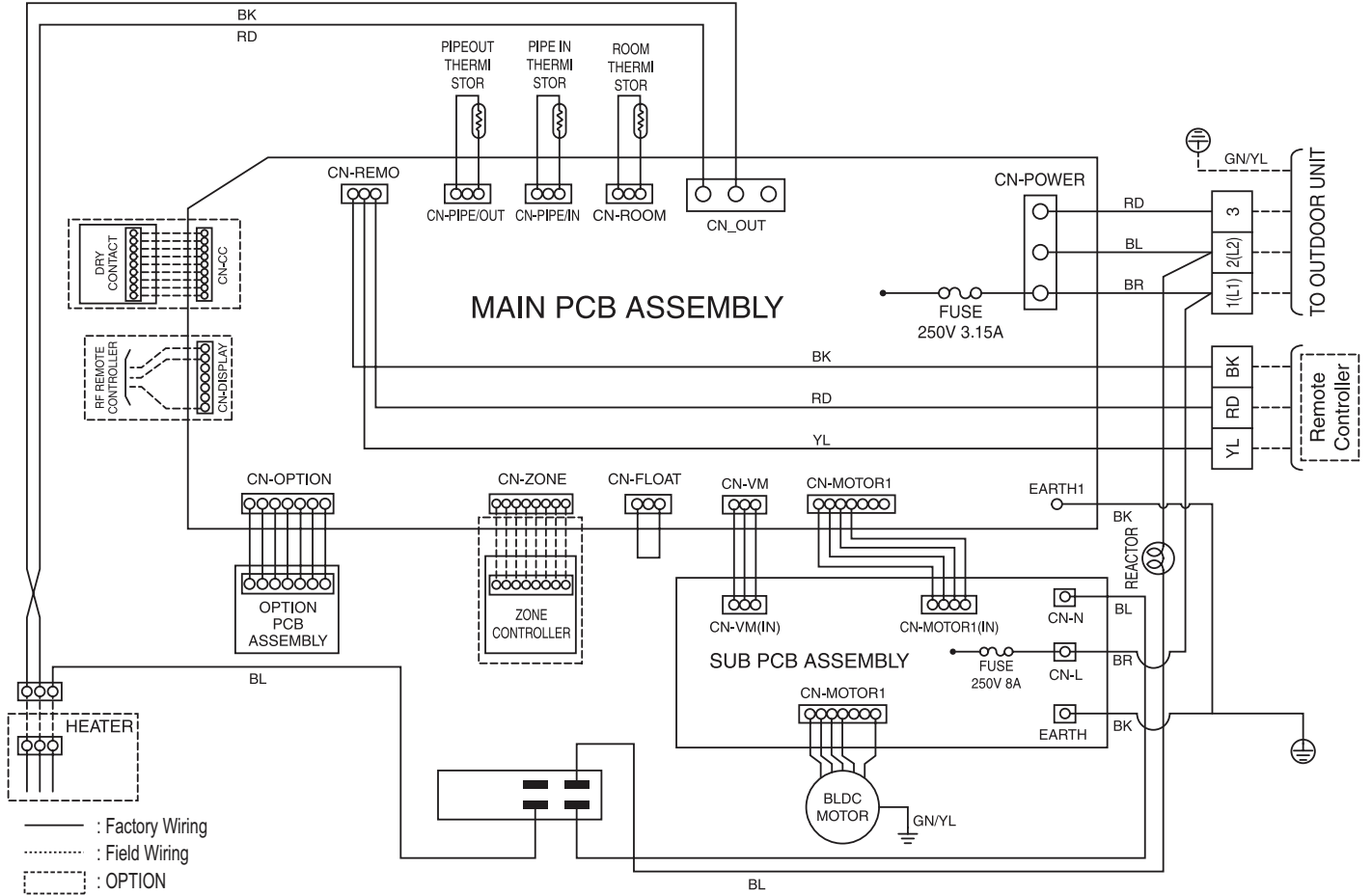


Table 93: Wiring Diagram Connections.

Connection Name	Location	Function
CN-POWER	AC power supply	AC Power line input for indoor controller
CN-MOTOR1	Fan motor output	Motor output of BLDC
CN-MOTOR2	Fan motor output	Motor output of BLDC
CN-FLOAT	Float switch input	Float switch sensing (water level sensor)
CN-PIPE/IN	Suction pipe sensor	Pipe in thermistor
CN-PIPE/OUT	Discharge pipe sensor	Pipe out thermistor
CN-ROOM	Room sensor	Room thermistor
CN-REMO	Remote controller	Remote control line
CN-OPTION	Option PCB	Communication between main and option
CN-ZONE	Zone controller	Zone control line
CN-DISPLAY	RF Remote controller	RF Remote control line
CN-CC	Dry contact	Dry contact line

Table 94: DIP Switch Settings.

Dip Switch Settings		OFF	ON	Description
SW3	GROUP	Master	Slave	Group control setting using wired remote controller.
SW4	DRY CONTACT	Variable	Auto	Dry contact mode setting. 1. Variable: Auto/manual mode can be chosen using the wide wired remote controller or wireless remote controller (factory setting is the manual mode). 2. Auto: For dry contact, it is always auto mode.
SW5	EXTRA1	Off	On	<ul style="list-style-type: none"> • ON: Fan operates continuously. • OFF: Default (Fan does not operate continuously).
SW6	HEATER	Off	On	<ul style="list-style-type: none"> • ON: Automatic heater operation. • OFF: Default (manual heater operation).

- Indoor unit without electric heater.
 - DIP switch 1, 2, 6, 8 must be set to OFF.
- Indoor unit with electric heater, DIP switches 5 and 6 must be set to ON.
 - SW 5 ON: Fan operates continuously. (Can have uninterrupted heating during defrost or oil return modes using continuous heater and fan operation.)
 - SW5 OFF: Fan discontinuous operation. (There would be reduction in heating capacity while defrosting or oil return operation.)
 - SW6 ON: Automatic heater operation. (Heater operates automatically using the heater algorithm.)
 - SW6 OFF: Manual heater operation. (On / off operation is set manually. Heater operation follows the heater algorithm.)

VERTICAL-HORIZONTAL INDOOR UNITS

Factory Supplied Parts and Materials

MULTI F
MULTI F MAX

Factory Supplied Materials

- Owner's Manual
- Installation Manual
- Simple Controller with Mode Selection (AKB72955816)¹

¹Simple Mode Controllers for the vertical-horizontal air handling indoor units are also referenced by Model No. PQRCVCL0QW.

Required Tools

- Level
- Screwdriver
- Electric drill
- Hole core drill
- Flaring tool set
- Torque wrenches
- Hexagonal wrench
- Gas-leak detector
- Thermometer

WARNING

- Read all instructions before installing the product.
- Installation work must be performed by authorized personnel and in accordance with the national wiring standards and all local codes.

Selecting the Best Location

Do's

- Place the unit where air circulation through the ducts will not be blocked.
- Place the unit where drainage can be obtained easily.
- Place the unit where noise prevention is taken into consideration.
- Ensure there is sufficient strength to bear the load of the indoor unit.
- Ensure there is sufficient maintenance space.
- Locate the indoor unit in a location that is level, and where it can be easily connected to the outdoor unit / branch distribution unit.

WARNING

Don'ts

- The unit should not be installed near a heat or steam source, or where considerable amounts of oil, iron powder, or flour are used.
- The unit should not be installed where sulfuric acid and flammable or corrosive gases are generated, vented into, or stored.
- Avoid installing the unit near high-frequency generators or near any equipment that generates an electromagnetic field (minimum 3-1/3 feet away).
- Do not install the unit near a doorway.

The unit may be damaged, may malfunction, and / or will not operate as designed if installed in any of the conditions listed.

Note:

If the unit is installed near a body of water, certain components are at risk of being corroded. Appropriate anti-corrosion methods should be taken for the unit and all components.

Installing in an Area Exposed to Unconditioned Air

In some installation applications, areas (floors, walls) in some rooms may be exposed to unconditioned air (room may be above or next to an unheated garage or storeroom). To countermeasure:

- Verify that carpet is or will be installed (carpet may increase the temperature by three degrees).
- Add insulation between the floor joists.
- Install radiant heat or another type of heating system to the floor.

Installing in an Area with High Humidity Levels

If the environment is prone to humidity levels of 80% or more (near the ocean, lakes, etc.) or where steam could collect in the plenum:

- Install additional insulation to the indoor unit (glass wool insulation >13/32 inches thick).
- Install additional insulation to the refrigerant piping (insulation >13/16 inches thick).
- Seal all gaps between the indoor unit and the ceiling tiles (make the area air tight) so that humidity does not transfer from the plenum to the conditioned space. Also, add a ceiling grille for ventilation.

Figure 225: Clearance Requirements.

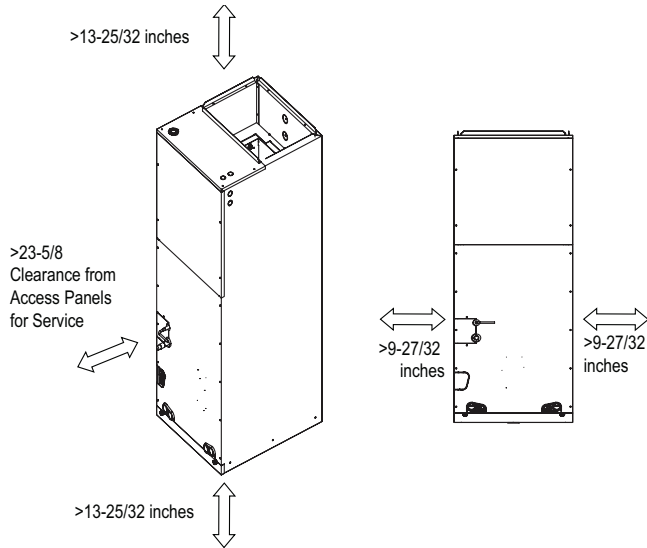


Figure 226: General and Duct Connection Dimensions.

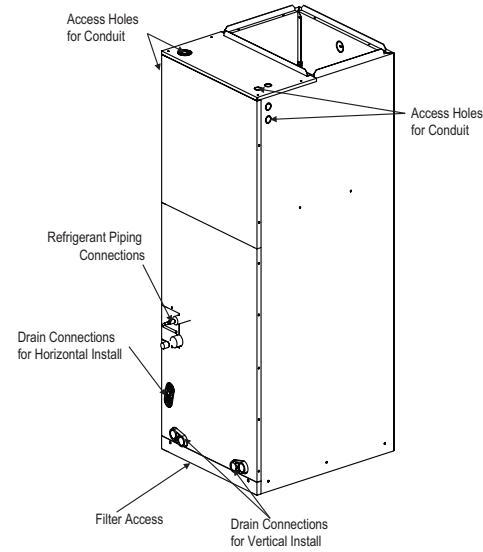


Figure 227: Location of Access Holes and Piping Connections.

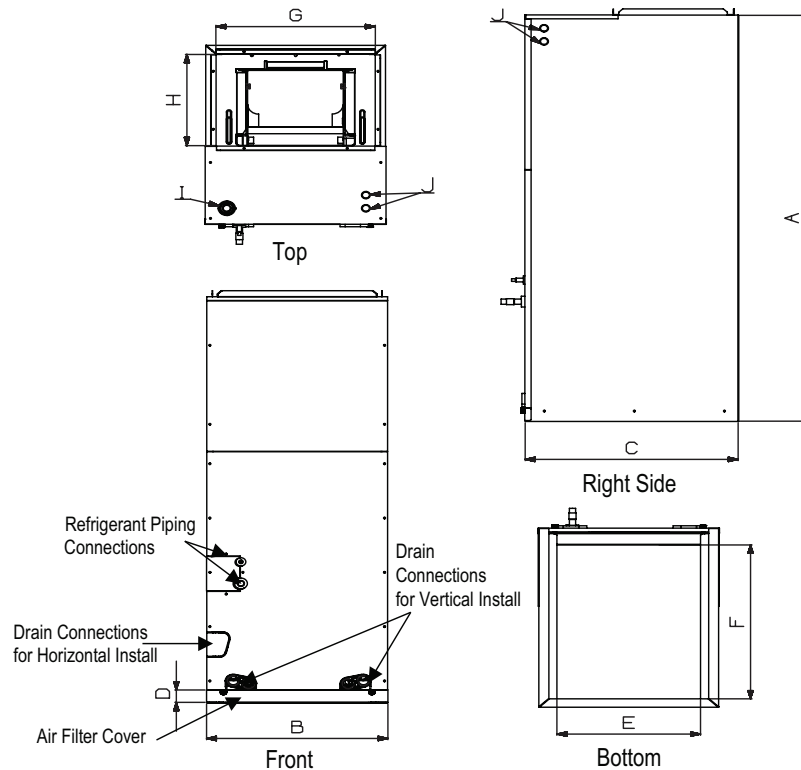


Table 95: General and Duct Connection Dimensions.

Capacity (Btu/h)	Dimensions (inches)								Access Hole for Wiring / Cable (inches)		Refrigerant Connection Sizes (inches)	
	A	B	C	D	E	F	G	H	I	J	Liquid	Vapor
	Height	Width	Depth						Power	Comm.		
24,000	48-21/32	18	21-1/4	1-9/16	17-1/2	20	17	12-1/8	1-11/16	7/8	1/4	1/2
36,000											3/8	5/8

VERTICAL-HORIZONTAL INDOOR UNITS

Installation and Best Layout Practices

MULTI F
MULTI F MAX

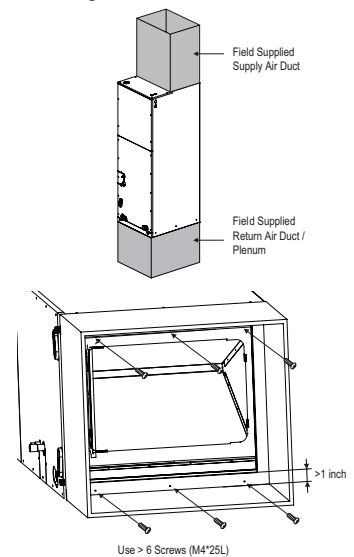
Note:

Vertical-Horizontal Air Handling Units can be installed in a choice of vertical (upflow) or horizontal (left side) configurations.

Vertical (Upflow) Installation

- Unit must be positioned properly for plenum / duct installation.
- To maintain proper air flow, minimum height clearance is 14 inches.
- Plenum must be strong and secure enough to support the installation of adapter collars to accommodate duct work.
- Air handler platform should be sturdy enough to support the frame, plus any accessories (i.e., filter box).
- To prevent air leaks, seal all duct work according to local codes, but make sure that filter access is still unobstructed.
- Vibration isolators (field supplied) must be installed between the unit frame and the platform. If necessary, provide the installing contractor with an illustration of where the vibration isolator should be added and how it should be positioned.

Figure 228: Vertical Installation / Attaching the Bottom Duct.



Note:

Do not install the screws on the front and back of the unit, doing so may block filter installation.

Horizontal Installation

- Units must be installed so that the access panels face to the side, not facing up or down.
- Installation must be in accordance with all relevant building codes, which may necessitate the installation of an external condensate pan (position the unit in or above the external condensate pan).
- If the units are going to be suspended, use angled steel support brackets with threaded rods to provide support from the bottom. The brackets / threaded rods should be comparatively bigger / longer than the unit, and each must be centered on the part of the frame it supports.
- If the unit will not be suspended, still use angled steel support brackets, but also add vibration isolators (field supplied) to avoid sound transmission. If necessary, provide the installing contractor with an illustration of where the vibration isolator should be added and how it should be positioned.

Figure 229: Horizontal Installation.

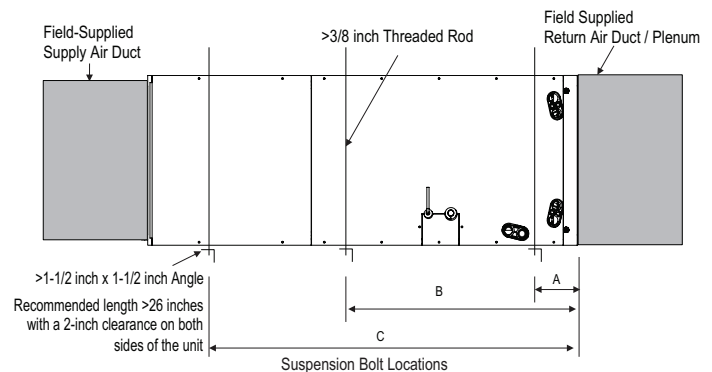


Table 96: Bracket / Bolt Position Dimensions.

Capacity (Btu/h)	Dimensions (inches)		
	A	B	C
24,000	4	23	41-11/32
36,000			

- Unit must be positioned properly for plenum / duct installation.
- Plenum must be strong and secure enough to support the installation of adapter collars to accommodate duct work.

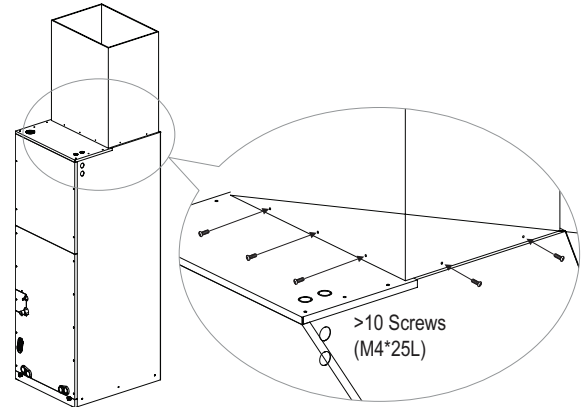
Note:

To ensure proper drainage for horizontal installations, unit must be installed within $\pm 1/8$ inches level of the unit's length and width.

Installing the Ducts

- Use more than ten (10) screws to securely attach the supply ducts to the unit. To prevent air leaks, seal around the duct opening before the duct is secure.
- To prevent vibration transmission, install flexible connectors between ducts and the unit. The flexible connectors must be made of a heat-resistant material at the discharge connection if an electric heater is installed.
- Duct work must be insulated and covered with vapor barrier when routed through unconditioned spaces. Include enough insulation to prevent condensate from forming on the ducts.
- It may be necessary to add internal acoustical insulation lining for a metal duct system if it does not include a 90° elbow and ten (10) feet between the main duct and the first branch.
- Fibrous glass ducts could be used as a substitute if built and installed in accordance with the most recent edition of the Sheet Metal and Air-Conditioning Contractors' National Associate (SMACNA) standard.
- Also, fibrous duct work and acoustical insulation lining must also follow National Fire Protection Standard 90A or B as tested by UL Standard 181 for Class 1 air ducts.

Figure 230: Securing the Ducts to the Unit.

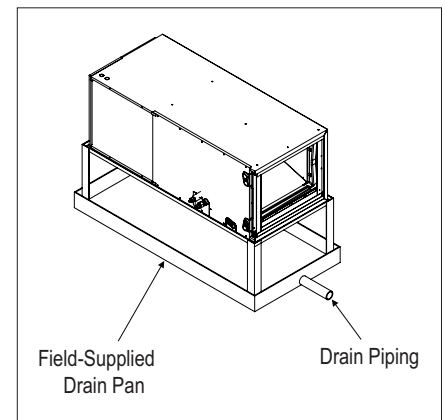
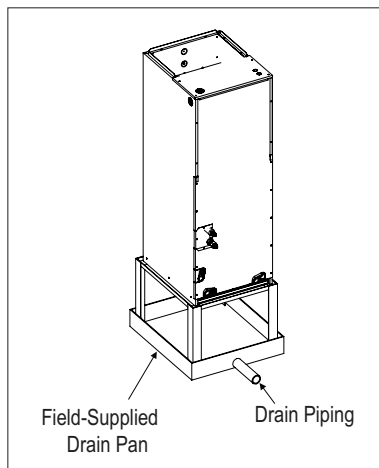


Installing the Drain System

General Specifications

- To prevent property damage, optimize drain system performance by installing both a primary and secondary drain line, and properly size the condensate traps.
- The primary and secondary drain line must be trapped to allow proper drainage of condensate water. If the secondary drain line is not used, it must be capped.
- Do not block the filter access panel when installing the condensate drain piping. Prime the primary and secondary condensate traps after running both to the drain pan.
- If the unit is installed above an inhabited space, add a field-supplied external condensate pan that runs underneath the entire frame (to prevent damage from overflow). The additional external condensate line should run from the unit to the external condensate pan.
- Drain all generated condensate from the external condensate pan to an appropriate area. Install a trap in the condensate lines as near to the indoor unit coil as possible.
- All condensate should be drained from the external condensate pan to some noticeable area.
- To prevent overflow, the outlet of each trap should be positioned below its connection to the condensate pan.
- All traps should be primed, insulated, and leak tested if located above an inhabited space.
- Use a 3/4-inch PVC male pipe thread fitting at the condensate pan connection. Tighten gently.
- Point the drain hose down for easier flow.
- Do not just use the pipe joint or PVC / CPVC piping on the indoor unit drain line connections. Use only Teflon tape.
- Design the drain system to plan for winter operation (condensate line may freeze up if condensate does not properly drain away).

Figure 231: Vertical Installation Drain System. Figure 232: Horizontal Installation Drain System.



VERTICAL-HORIZONTAL INDOOR UNITS

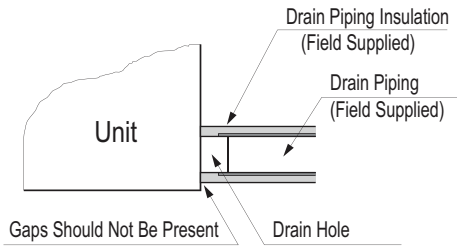
Installation and Best Layout Practices

MULTI F
MULTI F MAX

Drain Piping Specifications

- Drain piping must have downward gradient of at least 1/50 to 1/100; to prevent reverse flow, slope should not be straight up and down.
- Do not damage the drain port on the indoor unit when connecting the field-supplied drain piping.

Figure 233: Close up of Drain Piping Connection.



Field-Installed U-Trap Specifications

Note:

To prevent leaks cause by a block in the intake air filter, install a U-Trap.

A ≥ 2-9/16 inches

B ≥ 2C

C ≥ 2 x SP

SP = External Pressure in. WG

Example:

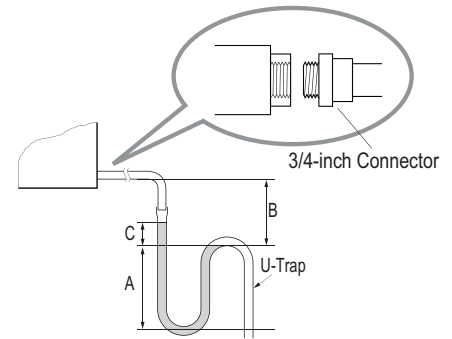
External Pressure= 0.4 in WG

A ≥ 2-9/16 inches

B ≥ 1-7/12 inches

C ≥ 19/24 inches

Figure 234: Installing the U-Trap.



Insulating the Refrigerant and Drain Piping

Refrigerant Piping Insulation

Field-installed vapor and liquid refrigerant piping lines must be properly and completely covered in insulation (up to the indoor unit piping connections) and must comply with federal, state, and local requirements. Any exposed piping may generate condensate or will cause burns if touched. Insulation for this field-installed refrigerant piping must have a minimum heat resistance of 248°F.

Vertical-horizontal air handling indoor units have been tested under and meet the requirements of the "KS Conditions." If the indoor unit is installed and is operated at an extended period in a highly humid environment (dew point temperature >73°F), however, condensate will form. To prevent this phenomenon, install adiabatic glass wool insulation with a thickness of 7/16 to 13/16 inches thick. Also, install glass wool insulation on all indoor unit that are located in the ceiling plenum.

Drain Piping Insulation

Drain piping must have insulation a minimum of 7/32 inches thick.

Figure 237: Close Up of Refrigerant Piping Connection Insulation.

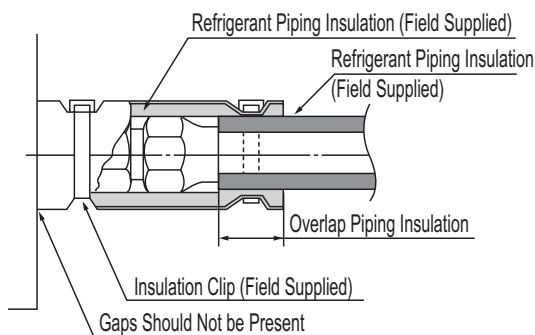


Figure 235: Vertical Primary and Secondary Drain Layout.

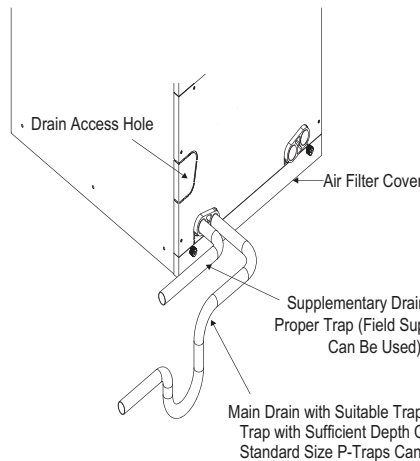


Figure 236: Horizontal Primary and Secondary Drain Layout.

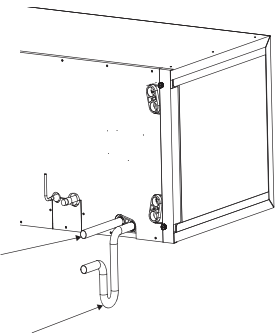
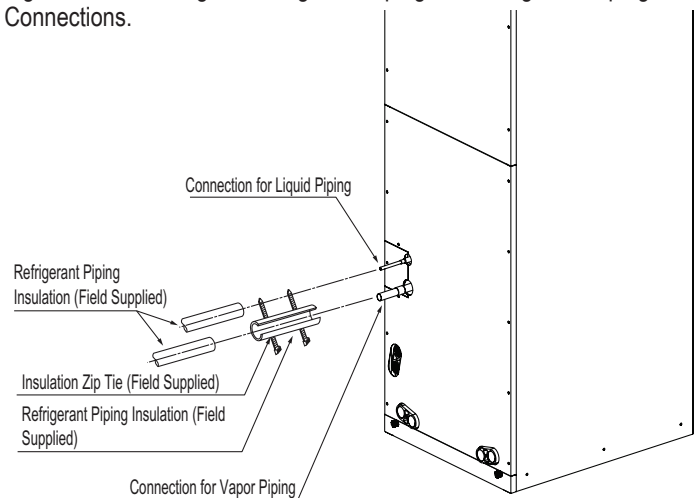


Figure 238: Insulating the Refrigerant Piping and Refrigerant Piping Connections.



Power Wiring / Communications Cable Guidelines

- Follow manufacturer's circuit diagrams in the technical manuals.
- Confirm power source specifications.
- Confirm that the electrical capacity is sufficient.
- Starting current must be maintained ± 10 percent of the rated current marked on the outdoor unit name plate.
- Confirm cable thickness specifications.
- It is recommended that a circuit breaker is installed, especially if conditions could become wet or moist.
- Include a disconnect in the power wiring system, add an air gap contact separation of at least 1/8 inch in each active (phase) conductor.

⚠ WARNING

- Loose wiring may cause unit malfunction, or the terminal to overheat and catch fire.
- Terminal screws may become loose during transport. Properly tighten the terminal connections during installation.

A voltage drop may cause the following problems:

- Magnetic switch vibration, fuse breaks, or disturbance to the normal function of an overload protection device.
- Compressor will not receive the proper starting current.

Connecting the Power Wiring and Communications Cable

1. To access the terminal block, first unscrew the top front panel, and then unscrew the cover from the control box.
2. Knockout the access holes for the wiring. Insert the power wiring / communications cable from the outdoor unit or branch distribution unit (Multi F MAX systems only) through the conduits, pass the conduits through the designated access holes, and then insert the conduits into the control box. To prevent electromagnetic interference and product malfunction, leave a space between the power wiring and communications cable outside of the indoor unit.
3. Connect the power wiring and communications cables to the appropriate terminals on the indoor unit control board. Verify that the color and terminal numbers from the outdoor unit or branch distribution unit (Multi F MAX systems only) wiring match the color and terminal numbers on the indoor unit.
4. Fill in any gaps around the conduit access holes with sealant to prevent foreign particles from entering the indoor unit.

Figure 239: Connecting the Power Wiring and Communications Cable.

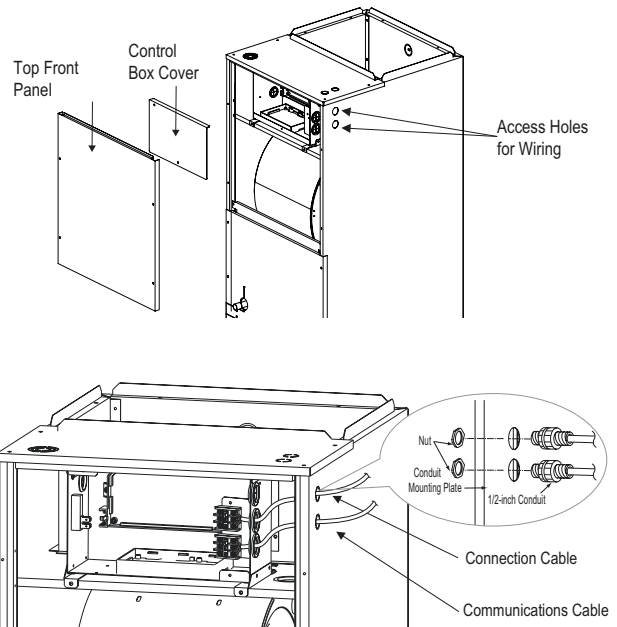
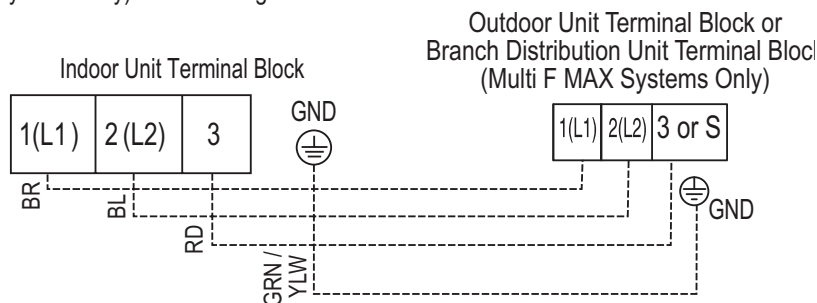


Figure 240: Indoor Unit to Outdoor Unit / Branch Distribution Unit (Multi F MAX systems only) Power Wiring / Communications Cable Connections.



VERTICAL-HORIZONTAL INDOOR UNITS

Installation and Best Layout Practices

MULTI F
MULTI F MAX

Controller Options

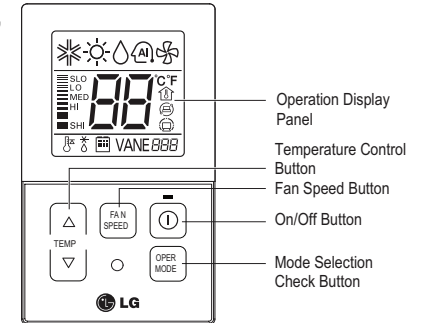
Vertical-Horizontal Air Handling indoor units include an LG-supplied wired controller (AKB72955816)¹, but other optional LG-supplied wired controllers are available (see Controls and Options overview on pages 9 to 12 in this manual's Introduction section). The wireless handheld controller (Model No. PQWRHQ0FDB) is also an optional accessory with use of the wired controller.

- Operation Display Panel: Displays operation conditions.
- Temperature Control Button: Sets desired temperature.
- Fan Speed Button: Sets desired fan speed.
- On / Off Button: Turns system operation on and off.
- Mode Selection Check Button: Selects the operation mode: Cooling, Heating, Auto, Dry (Dehumidification), or Fan.

Note:

Each function will display on the LED for about three (3) seconds when the power is first cycled on.

AKB72955816¹ Wired Controller.



¹Simple Mode Controllers for the vertical-horizontal air handling indoor units are also referenced by Model No. PQRCVCLQW.

Wired Controller Connections

Controllers can connect to the indoor unit in one of two different ways.

1. LG Wired Remote Extension Cable with Molex plug (PZCWRC1; sold separately) that connects to the CN-REMO terminal on the indoor unit PCB.
2. Field-supplied controller cable that connects to the indoor unit terminal block (must be at least UL2547 or UL1007, 22 AWG, two-core, one-shield core, at least FT-6 rated if local electric and building codes require plenum cable usage).

Figure 241:PZCWRC1 LG Wired Remote Extension Cable.

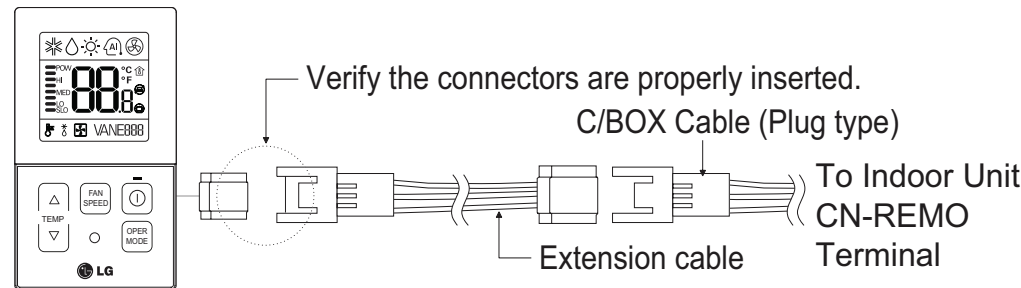
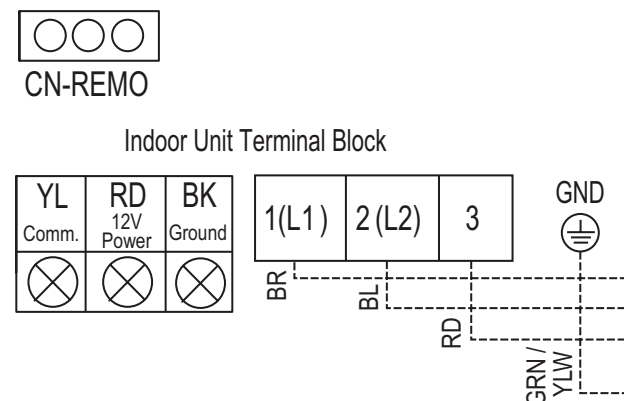


Figure 242:Wired Controller Connection on the Indoor Unit Terminal Block.



Note:

When using field-supplied controller cable, make sure to connect the yellow to yellow (communications wire), red to red (12V power wire), and black to black (ground wire) terminals from the remote controller to the indoor unit terminal blocks.

Wired Controller Placement

Wired controllers include a sensor to detect room temperature. To maintain comfort levels in the conditioned space, the wired controller must be installed in a location away from direct sunlight, high humidity, and where it could be directly exposed to cold air. Controller must be installed four (4) to five (5) feet above the floor where its LED display can be read easily, in an area with good air circulation, and where it can detect an average room temperature.

Do not install the wired controller near or in:

- Drafts or dead spots behind doors and in corners
- Hot or cold air from ducts
- Radiant heat from the sun or appliances
- Concealed pipes and chimneys
- An area where temperatures are uncontrolled, such as an outside wall

Hanging the Wired Controller

1. The controller wiring / cable can be installed in one of three directions: top, back, or on the right side. If top or right side installation is desired, remove cable guide grooves on the controller, and then position wiring / cable on applicable side.
2. Choose and mark the area of installation, and then screw the wall plate into place (using the provided parts). Install the controller wall plate to fit the electrical box if one is present. Ensure that no gaps exist between the wall plate and the wall itself.
3. Arrange wiring / cables so as not to interfere with the controller circuitry. Position the wired controller on the wall plate. Snap into place by pressing the bottom part of the wired controller onto the wall plate. Make sure that no gaps exist between the wired controller and the wall plate on all sides.
4. To remove wired controller from the wall plate, insert a screwdriver into the two holes at the bottom. Twist screwdriver to release controller. Do not damage the controller components when removing.

Assigning the Thermistor for Temperature Detection

Each indoor unit includes a return air thermistor assigned to sense the temperature. If a wired controller is installed, there is a choice of sensing temperature with either the indoor unit return air thermistor or the thermistor in the wired controller. It is also an option to set both thermistors to sense temperature so that indoor unit bases its operation on the first thermistor to reach the designated temperature differential. For applicable indoor units, an optional Remote Temperature Sensor can be used in lieu of the return air thermistor—either alone or in conjunction with a wired controller thermistor as previously described.

Figure 243: Proper Location for the Wired Controller.

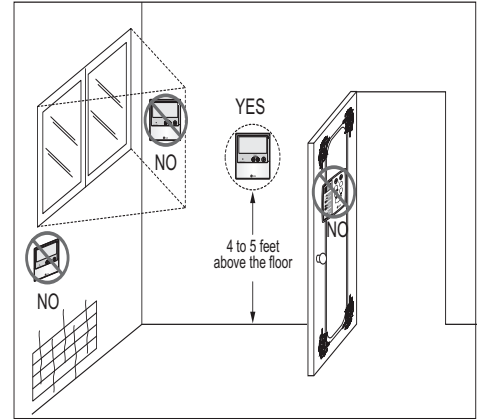


Figure 244: Removing the Cable Guide Grooves.

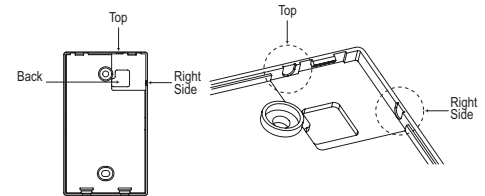


Figure 245: Attaching the Wall Plate.

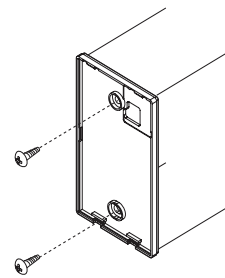
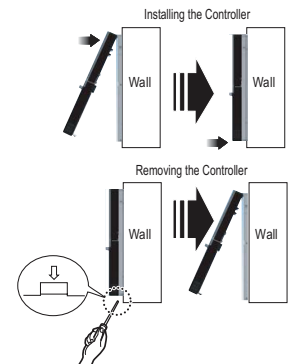


Figure 246: Installing / Removing the Controller.



APPLICATION GUIDELINES

“Equipment Selection Procedure” on page 174

“Building Ventilation Design Guide” on page 180

“Placement Considerations” on page 185

To choose the multi-zone system that is the most appropriate for the space, as with traditional air-conditioning systems, follow similar protocols outlined in Manual J from the Air Conditioning Contractors of America (ACCA; see www.acca.org).

1. Obtain the design conditions, and calculate the maximum cool and heat loads for the structure.
2. Select the equipment (choosing the appropriate indoor units and outdoor unit):
 - Determine number of zones.
 - Determine total number of indoor units (refer to zone load calculations when choosing indoor units).
 - Determine number of indoor units allocated to each outdoor unit, considering allowable indoor unit connections, both indoor unit and outdoor unit capacities, and system piping capabilities.
3. Determine the corrected capacity for the indoor units and outdoor unit using LATS Multi F software or:
 - System Combination Tables.
 - Capacity Tables (it may be necessary to interpolate).
 - Capacity Coefficient Factors (such as refrigerant line length derates, design condition derates, defrost operation derate [heating mode], altitude derate [if applicable]).
4. Compare corrected capacities to load calculations.
5. Reselect equipment if necessary.

Obtain Design Conditions, Calculate Maximum Cool / Heat Loads

Obtain the winter outdoor/indoor temperature and summer and winter outdoor/indoor temperature design parameters for the location in which the system is installed. Determine if summer or winter design gains, relative humidity, and building features like skylights, orientation, number of occupants, etc., would change the total heat loss / gain and sensible / latent heat gain, and then calculate the maximum cool and heat loads for the space (using Manual J or energy modeling programs).

Select the Equipment

Determine the Number of Zones

Multi F heat pump systems can cool or heat, but not simultaneously. When designing larger-capacity Multi F heat pump systems or a Multi F MAX system, the designer may be able to combine spaces with similar load profiles located near or adjacent to each other into “thermal zones.” After combining like spaces into zones that will be served by a single (or grouped) indoor unit(s), calculate the peak cooling and heating loads for each zone.

Choosing the Appropriate Indoor Units

Determine the appropriate indoor unit capacity that satisfies the given zone load calculations, choose how many (and which styles of) indoor units will be required. See Table 96 for allowable indoor unit to outdoor unit connections, and the maximum number of connectable indoor units on each Multi F and Multi F MAX outdoor unit. When choosing, also consider the cooling and heating CFM, featured airflow specifications, and static pressure (if applicable) for each indoor unit.

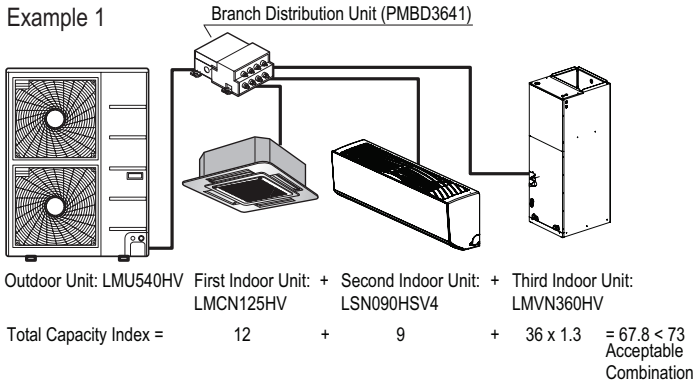
Avoid oversizing indoor units in an attempt to increase the air exchange rate in the space. Multi F and Multi F MAX systems are designed for minimum airflow over the coil to maximize latent capacity while cooling, maintain a comfortable, consistent discharge air temperature while heating, and minimize fan motor power consumption. In extreme cases, oversizing the indoor units may affect outdoor unit size selection and compromise the outdoor unit’s ability to effectively match the space load(s).

For proper system operation:

1. At least two indoor units must be connected to the outdoor unit.
2. Total connected indoor unit nominal capacity should be a minimum 40% and a maximum of 133% of outdoor unit nominal capacity.
3. To calculate the connected total indoor unit nominal capacity, simply sum up the nominal capacities of all indoor units.
 - For 24,000 and 36,000 Btu/h high static duct and vertical-horizontal air handling indoor units, a 1.3 multiplier must first be applied before adding to the sum of other smaller indoor units.
 - When two 24,000 Btu/h or one 24,000 Btu/h and one 36,000 Btu/h high static duct and / or vertical-horizontal air handling indoor units are the only connected indoor units, the multiplier is 1.2.

Multiplier Examples

Example 1



Example 2

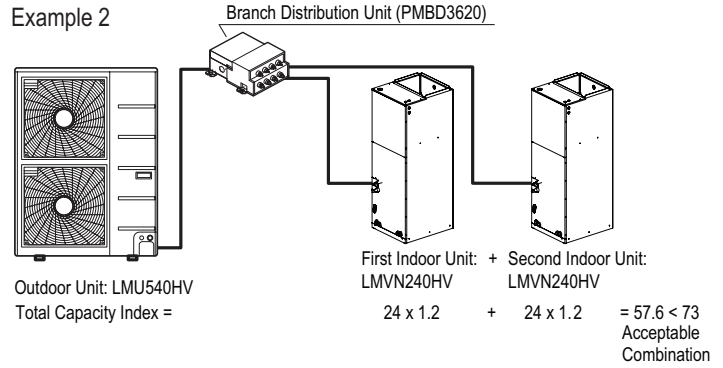


Table 97: Allowable Indoor Unit to Outdoor Unit Connections.

Indoor units		Outdoor units			
Model Type	Indoor Unit Nominal Capacity (Btu/h)	LMU18CHV	LMU24CHV	LMU36CHV	LMU540HV
		Maximum No. of Connectable Indoor Units			
		2	3	4	8
ART COOL Mirror	9,000	0	0	0	0
	12,000	0	0	0	0
	18,000	-	0	0	0
ART COOL Gallery	9,000	0	0	0	0
	12,000	0	0	0	0
	18,000	-	0	0	0
Wall Mounted	7,000	0	0	0	0
	9,000	0	0	0	0
	12,000	0	0	0	0
	15,000	0	0	0	0
	18,000	-	0	0	0
Ceiling Concealed Duct-Low Static	9,000	0	0	0	0
	12,000	0	0	0	0
	18,000	-	0	0	0
Ceiling Concealed Duct-High Static	24,000	-	-	0	0
	36,000	-	-	-	0
Four-Way Ceiling Cassette	7,000	0	0	0	0
	9,000	0	0	0	0
	12,000	0	0	0	0
	18,000	-	0	0	0
Vertical-Horizontal Air Handler	24,000	-	-	0	0
	36,000	-	-	-	0

Choosing the Appropriate Outdoor Unit

After all indoor units are properly sized to offset the applicable loads in each zone, select the outdoor unit by choosing a size that meets both the load-cooling requirement, and offsets the sum of the heating load. Then, the system's combination ratio should be evaluated and confirmed it is within the allowable range (the combination ratio compares the nominal capacity of all connected indoor units to the nominal capacity of the outdoor unit serving them). The total nominal capacity of all indoor units should be smaller than the total nominal capacity of the outdoor unit. If the combination ratio is more than 100%, the designer is undersizing the outdoor unit relative to the combined nominal capacity of the connected indoor units. In some designs, oversized indoor units may be unavoidable in the case where the smallest size indoor unit available from LG is larger than what is necessary to satisfy the zone load. This scenario may also occur when an indoor unit selection one size down from the selected unit is slightly short of fulfilling the design load requirements, and the designer must choose the next largest size unit. Sometimes it is recommended to choose a larger capacity outdoor unit if the installation space is big enough. Also, it may be prudent to oversize the outdoor unit to address those times when the weather conditions may exceed the design conditions, to minimize the possibility of ventilation systems that causes the space temperature to drift outside design parameters, or when the indoor unit's entering air temperature falls outside the approved design temperature range.

Table 98: Rated Outdoor Unit Capacity.

		Outdoor Units			
		LMU18CHV	LMU24CHV	LMU36CHV	LMU540HV
Rated Capacity (Btu/h)	Cooling	15,600	19,200	34,000	52,500
	Heating	17,000	26,400	41,000	58,000
Connectable Indoor Units	Minimum No. of Connectable Indoor Units	2	2	2	2
	Maximum No. of Connectable Indoor Units	2	3	4	8
	Maximum Capacity Index	24,000	33,000	48,000	73,000

Determine the Corrected Capacity

The *corrected* cooling / heating capacity is different from the rated cooling / heating capacity. The corrected capacity includes changes in unit performance after considering design temperatures, available capacity that can be allocated from the outdoor unit, pressure drop due to refrigerant line length, defrost operation in heating mode, and (if applicable) altitude. Depending on the location of the building, additional capacity correction factors may need to be applied.

Using the Outdoor Unit Cooling and Heating Capacity Tables

Rated cooling capacity ratings are obtained with air entering the indoor unit at 80°F dry bulb (DB) and 67°F wet bulb (WB), and outdoor ambient conditions of 95°F dry bulb (DB) and 75°F wet bulb (WB). Rated heating capacity ratings are obtained with air entering the indoor unit at 70°F dry bulb (DB) and 60°F wet bulb (WB) and outdoor ambient conditions of 47°F dry bulb (DB) and 43°F wet bulb (WB).

To evaluate the total outdoor unit capacity at design conditions perform a selection using LATS Multi F software (preferred method) or reference the Performance Data Capacity Tables found in the Multi F outdoor unit section in this manual. All design temperatures are not explicitly shown in the charts, therefore, interpolation may be necessary to calculate the capacity for specific design conditions. Based on the premise that capacity follows a linear curve, the following formula can be applied:

$$(y - y_1) / (y_2 - y_1) = (x - x_1) / (x_2 - x_1)$$

Where

- y = Missing Capacity (Capacity at the Design Temperature).¹
- y₁ = Capacity at Lower Temperature (Smaller value of the two nearest published TC datapoints).
- y₂ = Capacity at Higher Temperature (Higher value of the two nearest published TC datapoints).
- x = Design Temperature (Temperature not shown in published capacity tables).²
- x₁ = (Smaller value of the two nearest published temperature datapoints).
- x₂ = (Larger value of the two nearest published temperature datapoints).

¹Median between two published Total Capacity [TC] Btu/h datapoints in the capacity table.

²Median between two nearest published temperature datapoints.

Using the Indoor Unit Cooling and Heating Capacity Tables

The datapoints shown in the indoor unit cooling and heating capacity charts are based on (and convey) an indoor unit operating with maximum possible refrigerant flow from the outdoor unit and before any derates are applied. In other words, the capacities displayed reflect what the indoor unit would produce if it was the only indoor unit that required capacity, and the outdoor unit did not have to allocate any capacity to another indoor unit.

System operation with a combination of indoor units is not conveyed in these charts, however, the information can be used to calculate indoor unit allocated capacity (without using the system combination tables). Simply calculate by using the formula:

$$Qidu(\text{combi}) = Qodu(\text{rated}) \times \frac{Qidu(\text{rated})}{\Sigma Qidu(\text{rated})}$$

Where

Qidu(combi) = Individual Indoor Unit Combination Capacity.

Qodu(rated) = Outdoor Unit Rated Capacity.

Qidu(rated) = Individual Indoor Unit Rated Capacity.

ΣQidu(rated) = Total Connected Indoor Unit Rated Capacity.

Note:

- The formula can be used to find individual indoor unit capacity for Multi F MAX systems.
- A more accurate method to determine expected capacity would be to apply the outdoor unit's corrected capacity instead of rated capacity.

Using the System Combination Tables

Multi F system combination tables illustrate how each indoor unit receives a percentage of total outdoor unit rated capacity. Allocation is based on:

- Combinations of Non-Ducted Indoor Units
- Combinations of Ducted Indoor Units
- Combinations of Mixed Non-Ducted and Ducted Indoor Units

Multi F MAX system combination tables only show the total connected indoor unit capacity, but individual indoor unit capacity can be calculated using the formula:

$$Q_{idu}(\text{combi}) = Q_{odu}(\text{rated}) \times \frac{Q_{idu}(\text{rated})}{\sum Q_{idu}(\text{rated})}$$

Note:

A more accurate method to determine expected capacity would be to apply the outdoor unit's corrected capacity instead of rated capacity.

Capacity Coefficient Factors

Refrigerant Line Length Derates

For air-cooled systems, a capacity correction factor may have to be applied to account for the length of the system's refrigerant pipe. Rate of change in capacity due to increased piping lengths is shown in Table 99, Table 100, and Table 101.

Table 99: Multi F Outdoor Unit (Multiple Piping) to Indoor Unit Refrigerant Line Length Derates.

Piping Length (feet)	Cooling Capacity (%)	Heating Capacity (%)
7,000 Btu/h Indoor Unit Models		
25.0	100.0	100.0
32.8	98.4	99.2
49.2	95.8	97.8
65.6	93.2	96.4
82.0	90.6	95.0
9,000 Btu/h Indoor Unit Models		
25.0	100.0	100.0
32.8	98.0	99.0
49.2	94.8	97.4
65.6	91.6	95.8
82.0	88.4	94.2
12,000 Btu/h Indoor Unit Models		
25.0	100.0	100.0
32.8	97.6	98.6
49.2	93.8	96.4
65.6	89.9	94.1
82.0	86.1	91.9
15,000 Btu/h Indoor Unit Models		
25.0	100.0	100.0
32.8	97.2	98.2
49.2	93.0	95.4
65.6	88.8	92.6
82.0	84.6	89.8
18,000 Btu/h Indoor Unit Models		
25.0	100.0	100.0
32.8	98.6	99.6
49.2	96.4	99.0
65.6	94.1	98.3
82.0	91.9	97.7
24,000 Btu/h Indoor Unit Models		
25.0	100.0	100.0
32.8	98.2	99.2
49.2	95.4	98.0
65.6	92.4	96.6
82.0	89.6	95.4

EQUIPMENT SELECTION PROCEDURE

MULTI F
MULTI F MAX

Table 100: Multi F MAX Outdoor Unit to Branch Distribution Unit Refrigerant Line Length Derates.

Main Piping Length (feet)	16.4	32.8	49.2	65.6	82.0	98.4	114.8	131.2	147.6	164.0	180.4
Cooling Capacity (%)	100.0	98.8	97.3	95.8	94.3	92.8	91.3	89.8	88.3	86.8	85.3
Heating Capacity (%)	100.0	99.6	99.2	98.7	98.3	97.8	97.4	96.9	96.5	96.0	95.6

Figure 247: Multi F MAX Outdoor Unit to Branch Distribution Unit Refrigerant Line Length Derate Chart.

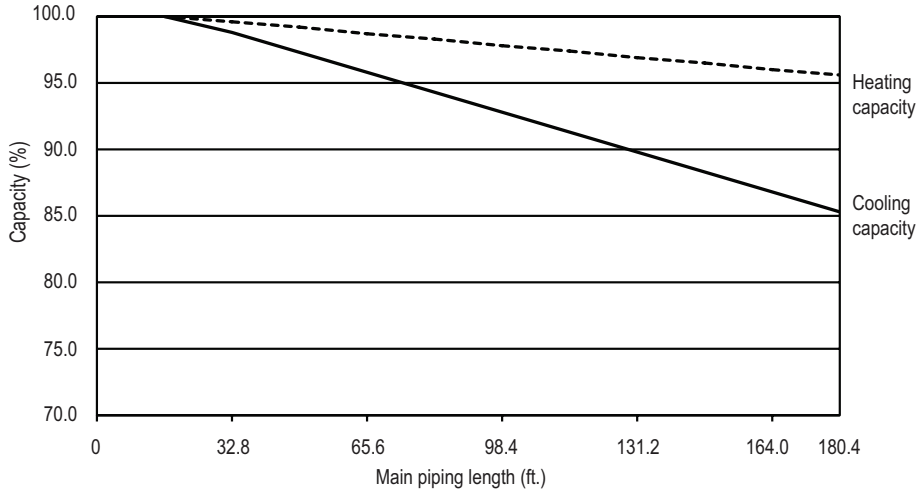


Table 101: Multi F MAX Branch Distribution Unit to Indoor Unit Refrigerant Line Length Derates.

Piping Length (feet)	Cooling Capacity (%)	Heating Capacity (%)
7,000 Btu/h Indoor Unit Models		
16.4	100.0	100.0
32.8	98.0	99.5
49.2	96.0	98.9
9,000 Btu/h Indoor Unit Models		
16.4	100.0	100.0
32.8	97.5	98.8
49.2	95.0	97.5
12,000 Btu/h Indoor Unit Models		
16.4	100.0	100.0
32.8	97.0	98.3
49.2	94.0	96.5
15,000 Btu/h Indoor Unit Models		
16.4	100.0	100.0
32.8	97.2	98.2
49.2	93.0	95.4
18,000 Btu/h Indoor Unit Models		
16.4	100.0	100.0
32.8	98.3	99.5
49.2	96.5	99.0
24,000 Btu/h Indoor Unit Models		
16.4	100.0	100.0
32.8	97.8	99.2
49.2	95.5	98.4
36,000 Btu/h Indoor Unit Models		
16.4	100.0	100.0
32.8	97.9	98.8
49.2	95.7	97.6

Altitude Correction Factor

The impact of air density must be considered on systems installed at a significant altitude above sea level, therefore, locally accepted altitude correction factors must be applied.

Defrost Correction Factor for Heating Operation

The outdoor unit heating capacity may need to be adjusted for frost accumulation on air-cooled systems. If design day conditions are below the dewpoint of the surrounding air, frost may not be a problem and no correction factor is needed. In certain weather conditions, however, frost may form and accumulate on the air-cooled outdoor unit coil and impact the coils ability to transfer heat. If significant frost accumulates on the outdoor unit coil, a defrost algorithm will start automatically. The timing between defrost periods is determined by the system's ability to achieve a target head pressure value.

Capacity and AHRI ratings tables do not factor in capacity reduction when frost has accumulated on the condenser coil, nor during defrost operation.

Integrated heating capacity values can be obtained using the formula:

$$A = B \times C$$

Where:

A = Integrated Heating Capacity.

B = Value found in the Capacity Table.

C = Correction Factor for Frost Accumulation Factor (from Table 101).

Note:

There will be temporary reduction in capacity when frost / ice accumulates on the outside surface of the outdoor unit heat exchanger. The level of capacity reduction depends on a number of factors, for example, outdoor temperature (°F DB), relative humidity (RH), and the amount of frost present.

Table 102: Outdoor Unit Frost Accumulation Factor (Heating)¹.

Entering DB (°F)	19.4	23.0	26.6	32.0	37.4	41.0	44.6
Derate factor	0.98	0.95	0.93	0.86	0.93	0.96	1.0

¹At 85% outdoor air relative humidity.

The frost accumulation factor does not account for effects of snow accumulation restricting airflow through the outdoor unit coil.

Check the Indoor and Outdoor Unit Selection(s)

Compare the corrected cooling and heating capacities to the load calculations. Is each capacity sufficient for the zone it serves?

For each indoor unit, the corrected capacity must be at least equal to the total of the cooling design load (plus ventilation load, if applicable) for the space(s) served by the indoor unit. For each indoor unit, the corrected capacity also must be at least equal to the total of the heating design load (plus ventilation load, if applicable) for the space(s) and / or thermal zones served by the indoor unit.

The outdoor unit selected should be large enough to offset the total cooling load for all spaces it serves (account for ventilation air cooling load if the ventilation air has not been pretreated to room neutral conditions). The outdoor unit should also be large enough to offset the total heating load for all spaces it serves.

If the corrected heating capacity ratio exceeds 100%, reselect the equipment, or change the system design by moving some of the load to another system.

System Sizing Check Formulas

1. Outdoor Unit Rated Capacity.

$Q_{odu(rated)}$ (From capacity tables).

2. Outdoor Unit Capacity at T_i , T_o Temperature.

$Q_{odu(T_i, T_o)}$ (From capacity tables).

3. Outdoor Unit Capacity Coefficient Factor.

$$F_{(T_i, T_o)} = Q_{odu(T_i, T_o)} / Q_{odu(rated)}$$

4. Piping Correction Factor (From Capacity Coefficient Factor Tables).

$F_{(length)}$ for each piping length

5. Individual Indoor Unit Combination Capacity.

$$Q_{idu (combi)} = Q_{odu(rated)} \times Q_{idu(rated)} / Q_{idu(rated-total)}$$

6. Individual Indoor Unit Actual Capacity.

$$Q_{idu (actual)} = Q_{odu(combi)} \times F_{(T_i, T_o)} \times F_{(length, altitude)}$$

Conclusions and Recommendations

- Understand the design safety factors.
- Reference load calculations for actual cooling and heating capacities (applies in 99% of applications – consider total load when latent load is greater than 30%).
- Verify that the sensible load of the zone is satisfied.

- Use caution when sizing to meet listed capacity specifications for the scheduled manufacturer's equipment.
- If further system design assistance is needed, or you have a unique application you would like to discuss, contact your LG sales rep.

ASHRAE Standards 62.1 and 62.2 (depending on if the building is residential or commercial), and local codes specify the minimum volume of airflow that must be provided to an occupied space. Outdoor air is required to minimize adverse health effects, and it provides acceptable indoor air quality for building occupants. Indoor units located within the zone typically require less airflow to condition the space. During the design phase, refer to the airflow capabilities listed in the specification tables for each product. Choose the best method for the application out of the five (5) ventilation options available.

Note:

Disclaimer

Although we believe that these building ventilation methods have been portrayed accurately, none of the methods have been tested, verified, or evaluated by LG Electronics, U.S.A., Inc., In all cases, the designer, installer, and contractor should understand if the suggested method is used, it is used at their own risk. LG Electronics U.S.A., Inc., takes no responsibility and offers no warranty, expressed or implied, of merchantability or fitness of purpose if this method fails to perform as stated or intended.

• For a complete copy of ASHRAE Standard 62.1 and 62.2, refer to the American Standard of Heating and Air Conditioning Engineers (ASHRAE) website at www.ashrae.org.

Method 1: Natural Ventilation (Non-Ducted, Unconditioned Outdoor Air)

Natural ventilation devices, such as operable windows or louvers may be used to ventilate the building when local code permits.

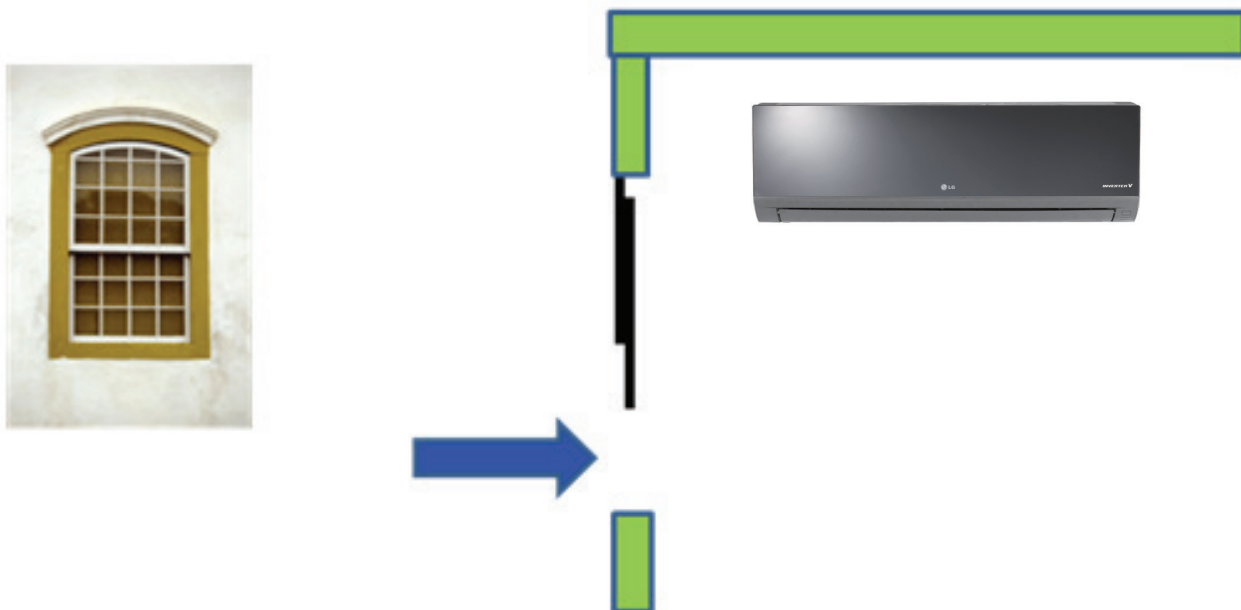
Advantages

- Occupants control the volume of the ventilation air manually.
- Useful for historic buildings that have no ceiling space available for outdoor air ductwork.
- May be used with the full lineup of Multi F indoor units.

Disadvantages

- In some locations, it may be difficult to control humidity levels when windows are open.
- Thermal comfort levels may be substandard when windows are open.
- Indoor units may have to be oversized to account for the added heating and cooling loads when windows are open.
- Provides outdoor air to perimeter spaces only. Additional mechanical ventilation system may be required to satisfy requirements for interior spaces.
- Outdoor air loads may be difficult to calculate since the quantity of outdoor air is not regulated.
- May affect indoor unit proper operation when open.

Figure 248: Natural Ventilation (Non-Ducted, Unconditioned Outdoor Air).



Method 2: Unconditioned Outdoor Air (Non-Ducted, Fan Assisted Ventilation)

When approved by local codes, the fan assisted ventilation method uses exhaust fans to remove air from the building, and outdoor air is drawn into occupied spaces through a wall louver or gravity roof intake hood. Supply fans can also be used to push the outdoor air into the space and building positive pressure will vent the exhaust air through louvers or roof-mounted exhaust hoods. Outdoor air is neither cooled nor heated before entering the building.

Note:

This may result in loss of building pressurization control, increasing infiltration loads with adverse effects.

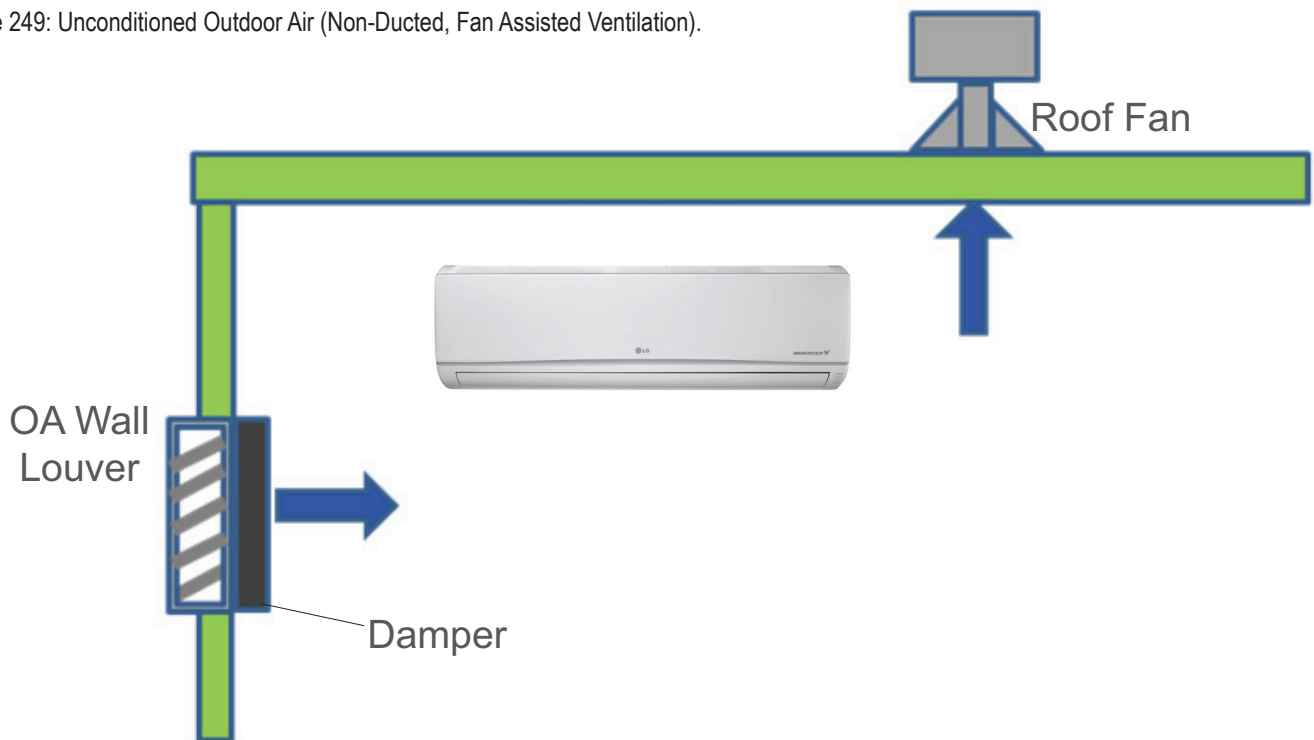
Advantages

- Outdoor air may be manually controlled by the occupant or automatic controls may be installed to open/close outdoor air dampers or to turn on/off ventilation fans.
- Useful for large open spaces like warehouses, garages, and workshops.
- Outdoor air volume is a known quantity. Air loads may be easier to calculate since fans will regulate the amount of outdoor air.
- May be used with the full lineup of Multi F indoor units.

Disadvantages

- In some locations of the country, it may be difficult to control humidity levels.
- Indoor units may have to be oversized to account for the added heating/cooling loads when louvers/hoods are open.
- Hot, cold, and/or humid areas may be present if the outdoor air is not evenly distributed to the different spaces.

Figure 249: Unconditioned Outdoor Air (Non-Ducted, Fan Assisted Ventilation).



Method 3: Unconditioned Outdoor Air Ducted to Indoor Units

Untreated outdoor air is channeled through a duct system that is piped to the return air duct on Multi F ducted indoor units or to the frame of Multi F four-way cassettes.

Note:

Outside air may flow backward through the return air-filter grille when the indoor unit fan speed slows or stops in response to changes in the space load. This may result in captured particulate on the filter media being blown back into the conditioned space.

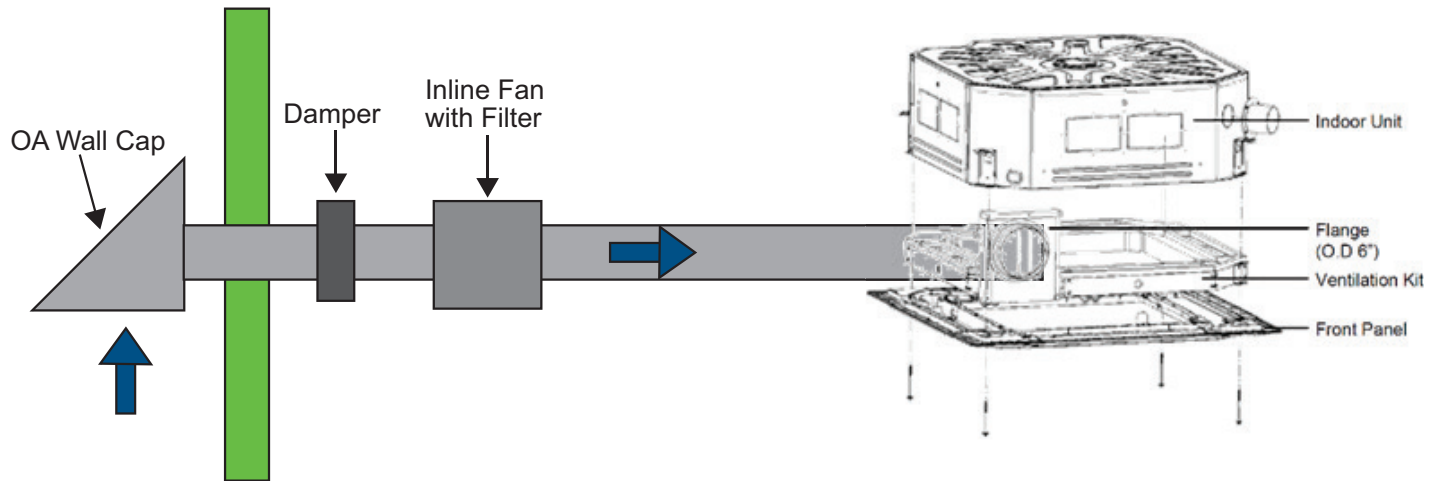
Advantages

- May require less ductwork if indoor units are placed near outdoor walls or a roof deck.
- Controls must be interlocked to shut off the outdoor air supply fan when the space is unoccupied.
- Third-party demand-control ventilation controls may be installed to regulate outdoor intake based on the CO₂ levels of the occupied space.

Disadvantages

- Fan(s) will be required to push outdoor air to the indoor unit to overcome the additional static pressure.
- Filter required to be added to the outdoor air duct.
- Ducted and four-way cassette models are the only indoor units that accept the connection of an outdoor air duct to the unit case.
- In most cases, in lieu of using the factory mounted return-air thermistor on indoor units, a remote wall temperature sensor or zone controller will be needed to provide an accurate reading of the conditioned area temperature.
- Unconditioned outdoor air may affect indoor unit performance, which may necessitate oversizing the indoor unit.

Figure 250: Unconditioned Outdoor Air Ducted to Indoor Units.



Method 4: Coupled Dedicated Outdoor Air (CDOA)

A separate, dedicated outdoor air system delivers air directly to a Multi F indoor unit or to the return air duct system. After mixing with the return air stream, ventilation air passes through the indoor unit and into the conditioned space. The pretreatment system is capable of filtering, conditioning, and dehumidifying outdoor air to room neutral conditions.

Note:

Outside air may flow backward through the return air-filter grille when the indoor unit fan speed is reduced or stops when the space load is satisfied. This may result in captured particulate on the filter media being blown back into the conditioned space.

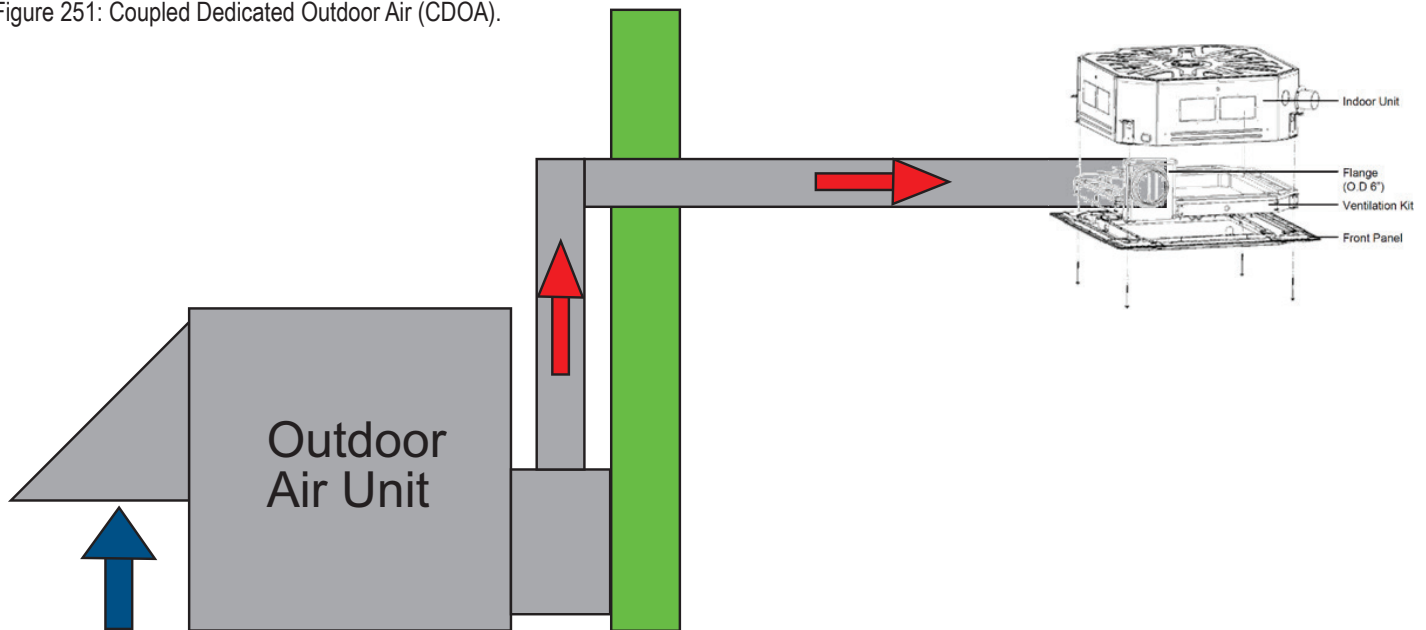
Advantages

- Indoor unit capacity may not need to be increased because of outdoor air.
- Fan and filter system is centralized to the main outdoor air unit.

Disadvantages

- Ducted and four-way cassette indoor units are the only models designed for direct connection of an outside air duct.
- Ceiling space is required for ductwork.
- Failure of outdoor air may impact indoor unit operation.
- In lieu of using the factory mounted return-air thermistor, a remote wall temperature sensor or zone controller may be required to provide an accurate conditioned space temperature reading.

Figure 251: Coupled Dedicated Outdoor Air (CDOA).



Method 5: Decoupled Dedicated Outdoor Air System (DDOAS)

Provide a separate, dedicated outdoor-air system designed to filter, condition, and dehumidify ventilation air and deliver it directly to the conditioned space through a separate register or grille. This approach requires a separate independent ventilation duct system not associated with the Multi F system.

Note:

LG recommends using the DDOAS method in all installations.

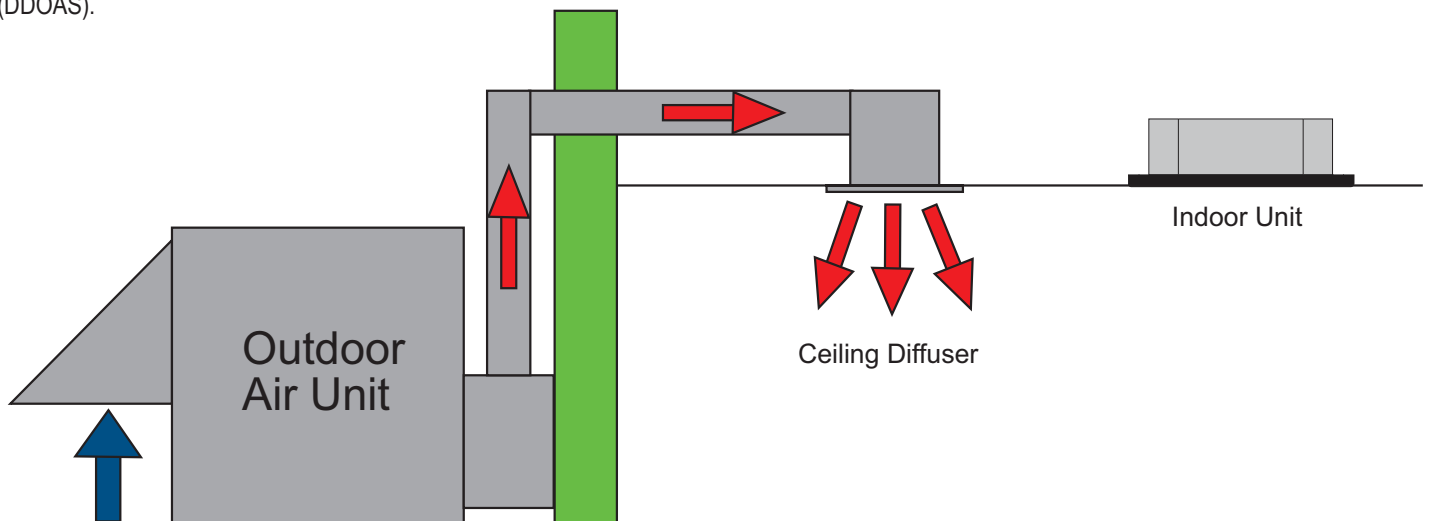
Advantages

- Does not add additional heating or cooling loads to indoor units.
- May be used with the full lineup of Multi F indoor units.
- Failure of outdoor unit does not impact operation of indoor unit, the resulting untreated air will be readily noticed by the occupants.
- The outdoor air unit may supply “neutral” air to the occupant space even when the Multi F indoor unit fan changes speed or cycles on and off. DDOAS controls do not have to be interlocked with the Multi V F system.
- In lieu of installing localized smaller outside air treatment equipment throughout the building, this method centralizes the ventilation air source making service and filter changes easier and less disruptive for the building occupants.
- Third-party demand control ventilation controls are more readily accommodated.
- Indoor unit operation and performance will not be affected by the condition of outdoor air.

Disadvantages

- Ceiling space is required to accommodate ductwork between the outdoor air unit and ceiling diffusers.

Figure 252: Decoupled Dedicated Outdoor Air System (DDOAS).



Selecting the Best Location for the Indoor Units

Select a location for installing the indoor units that will meet the following conditions:

- Within allowable parameters for proper connection to the outdoor unit (or Branch Distribution unit, if a Multi F MAX system).
- No obstacles to air circulation around the unit; keep proper distances from ceilings, doorways, floor, walls, etc.
- So that condensation drainage can be conveniently routed away.
- Include enough space around the indoor unit so that it is accessible for maintenance and service purposes.
- Where electrical noise / electromagnetic waves will not affect indoor unit operation. Maintain proper distances between the indoor units and electric wires, audio and visual appliances, breaker / circuit panels, etc. If the frequency signal of the appliance is unstable, then install the indoor unit a minimum of ten (10) feet away, and run the power and transmission cables through a conduit.
- An area that is level and with enough strength to bear the weight of the indoor unit(s).
- An area where operation sound won't disturb occupants.
- An area that does not expose the indoor unit(s) to heat, water, steam, oil splattering or spray.

Selecting the Best Location for the Branch Distribution (BD) Unit

Branch Distribution (BD) units are used only with Multi F MAX systems to distribute the refrigerant from the outdoor unit to up to eight indoor units. Select location indoors that will meet the following conditions:

- Within allowable parameters for proper connection to the Multi F MAX outdoor unit and indoor unit(s); refrigerant piping and wire lengths must not exceed amounts specified by LG Electronics, U.S.A., Inc.
- No obstacles to air circulation around the unit; keep proper distances from ceilings, doorways, floor, walls, etc.
- Condensate drain piping is not required.
- Ensure there is enough space in the installation area for service purposes; install the refrigerant piping and electrical wiring system in an easily accessible location.
- Do not install the BD unit in a location where it would be subjected to strong radiation heat from heat sources.
- Avoid an installation environment where the BD unit would be exposed to heat, water, steam, oil splattering or spray.
- Where high-frequency electrical noise / electromagnetic waves will not affect operation. Maintain proper distances between the BD unit(s) and electric wires, audio and visual appliances, breaker / circuit panels, etc.
- Level where there is enough strength to bear the weight of the BD unit.
- Install the unit in a location where any sound it generates will not disturb occupants in the surrounding rooms.

Selecting the Best Location for the Outdoor Unit

Select a location for installing the outdoor unit that will meet the following general conditions:

- A location strong enough to bear the weight of the outdoor unit.
- A location that allows for optimum air flow and is easily accessible for inspection, maintenance, and service.
- Where piping between the outdoor unit, indoor unit(s), and BD units (Multi F MAX systems only) are within allowable limits.
- Where it will not be subjected to direct thermal radiation from other heat sources, nor an area that would not expose the outdoor unit to heat or steam like discharge from boiler stacks, chimneys, steam relief ports, other air conditioning units, kitchen vents, plumbing vents, and other sources of extreme temperatures.
- Where operating sound from the unit will not disturb inhabitants of surrounding buildings.
- Where the unit will not be exposed to direct, strong winds.
- Where high-frequency electrical noise / electromagnetic waves will not affect operation.
- Include space for drainage to ensure condensate flows properly out of the unit when it is in heating mode. Avoid placing the outdoor unit in a low-lying area where water could accumulate.

Note:

When deciding on a location to place the outdoor unit, be sure to choose an area where run-off from defrost mode will not accumulate and freeze on sidewalks or driveways.

- To avoid the possibility of fire, do not install the unit in an area where combustible gas may generate, flow, stagnate, or leak.
- Don't install the unit in a location where oil, acidic solutions, sprays, or dust (sulfur, carbon, other corrosive materials) are present / often used.

Rooftop Installations

If the outdoor unit is installed on a roof structure, be sure to level the unit. Ensure the roof structure and anchoring method are adequate for the unit location. Consult local codes regarding rooftop mounting.

Oceanside Installation Precautions

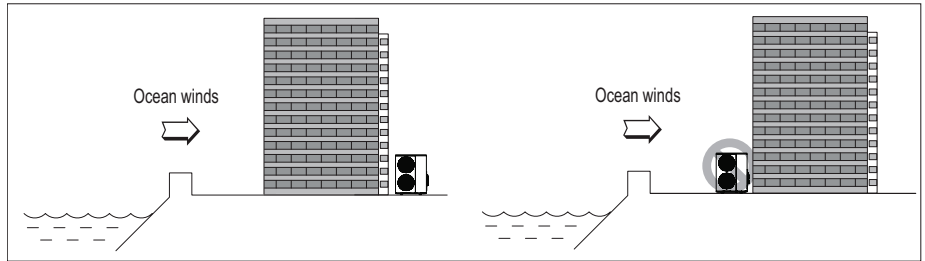
- Avoid installing the outdoor unit where it would be directly exposed to ocean winds.
- Install the outdoor unit on the side of the building opposite from direct ocean winds.
- Select a location with good drainage.
- Periodically clean dust or salt particles off of the heat exchanger with water.

Note:

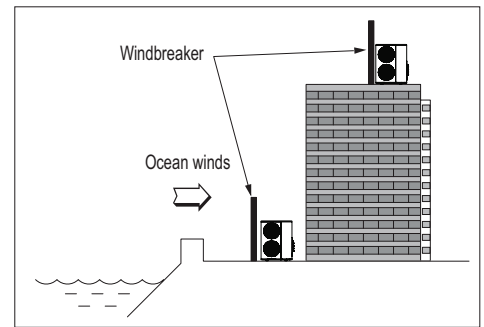
Additional anti-corrosion treatment may need to be applied to the outdoor unit at oceanside locations.

Note:

Ocean winds may cause corrosion, particularly on the condenser and evaporator fins, which, in turn could cause product malfunction or inefficient performance.



If the outdoor unit must be placed in a location where it would be subjected to direct ocean winds, install a concrete windbreaker strong enough to block any winds. Windbreaker height and width should be more than 150% of the outdoor unit, and be installed at least 27-1/2 inches away from the outdoor unit to allow for airflow.



Planning for Snow and Ice

In climates that experience snow buildup, place the unit on a raised platform to ensure proper condenser airflow. The raised support platform must be high enough to allow the unit to remain above possible snow drifts. Mount the unit on a field-provided snow stand at a minimum height that is equal to the average annual snowfall, plus 20 inches. Design the mounting base to prevent snow accumulation on the platform in front or back of the unit case. If necessary, provide a field fabricated hood to keep snow and ice and/or drifting snow from accumulating on the coil surfaces. Use inlet and discharge duct or hoods to prevent snow or rain from accumulating on the fan inlet and outlet guards. Best practice prevents snow from accumulating on top of the unit. Consider tie-down requirements in case of high winds or where required by local codes.

Outdoor Unit Platform Requirements

Figure 253: Outdoor Unit Foundation Requirements.

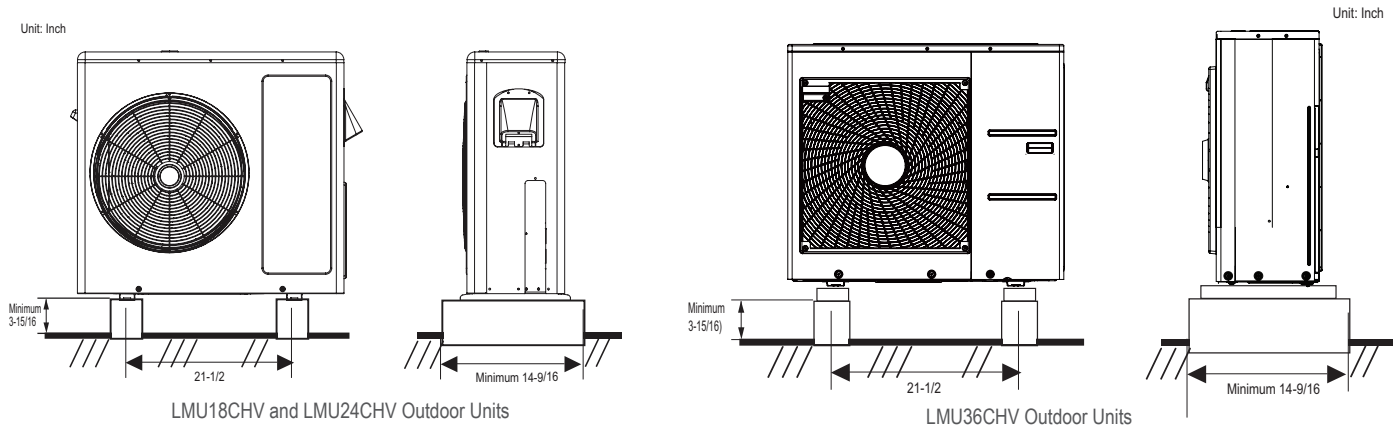
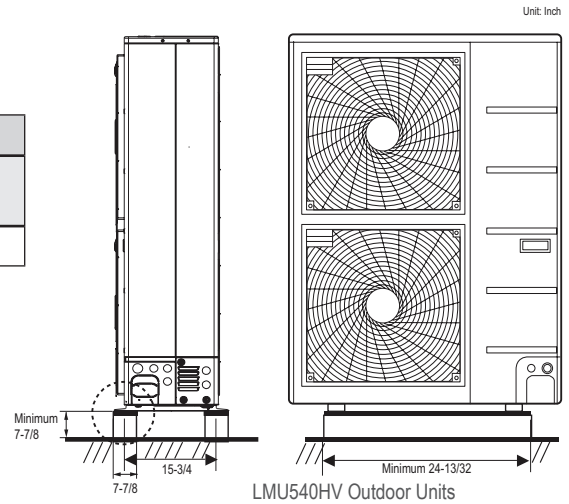


Table 103: Outdoor Unit Foundation Specifications.

Outdoor Unit Type	Bolt Type	Concrete Height	Bolt Depth
LMU18CHV, LMU24CHV, LMU36CHV	M10-J	Minimum 3-15/16 inches	Minimum 2-3/4 inches
LMU540HV	M10-J	Minimum 7-7/8 inches	Minimum 2-3/4 inches



Bolting the Outdoor Unit to the Platform

1. Ensure that the concrete platform will not degrade easily, and has enough strength to bear the weight of the unit.
2. Include an H-beam support. Firmly attach the corners, otherwise the support will bend.
3. Use a hexagon nut.
4. Use anti-vibration material.
5. Include enough space around the concrete foundation for condensate drainage.
6. Seal all wiring and piping access holes to prevent bugs from entering the unit.

Concrete Platform Specifications

- Concrete foundations should be made of one part cement, two parts sand, and four parts gravel.
- The surface of the foundation should be finished with mortar with rounded edges, and weatherproofed.

Figure 254: Bolting the Outdoor Unit to the Platform.

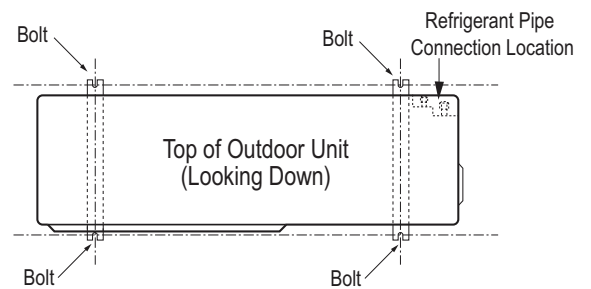
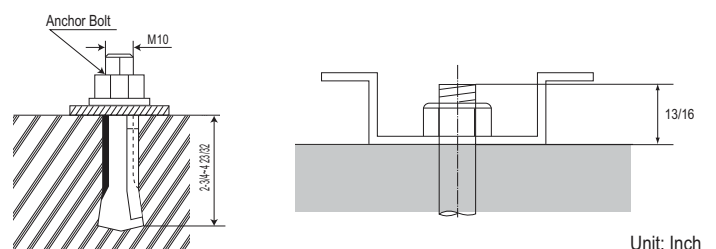


Figure 255: Close up of Bolt Attachment.



Tie-Downs and Lightning Protection

Tie-Downs

- The strength of the roof must be checked before installing the outdoor units.
- If the installation site is prone to high winds or earthquakes, when installing on the wall or roof, securely anchor the mounting base using a field-provided tie-down configuration approved by a local professional engineer.
- The overall tie-down configuration must be approved by a local professional engineer. Always refer to local code when using a wind restraint system.

Lightening Protection

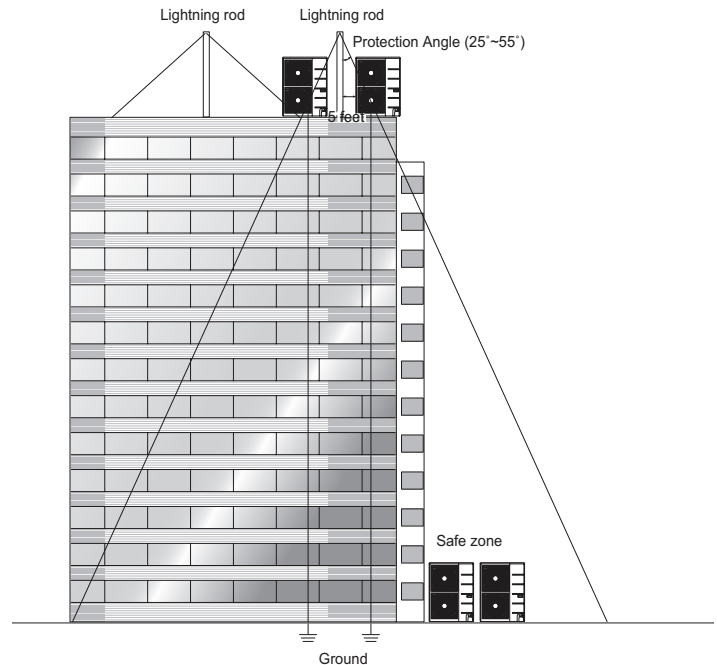
- To protect the outdoor unit from lightning, it should be placed within the specified lightning safety zone.

Table 104: Safety Zone Specifications.

Building Height (feet)	66	98	148	197
Protection Angle (°)	55	45	35	25

- Power cable and communication cable should be installed five (5) feet away from lightning rod.
- A high-resistance ground system should be included to protect against induced lightning or indirect strike.

Figure 256: Lightning Protection Diagram.



Note:

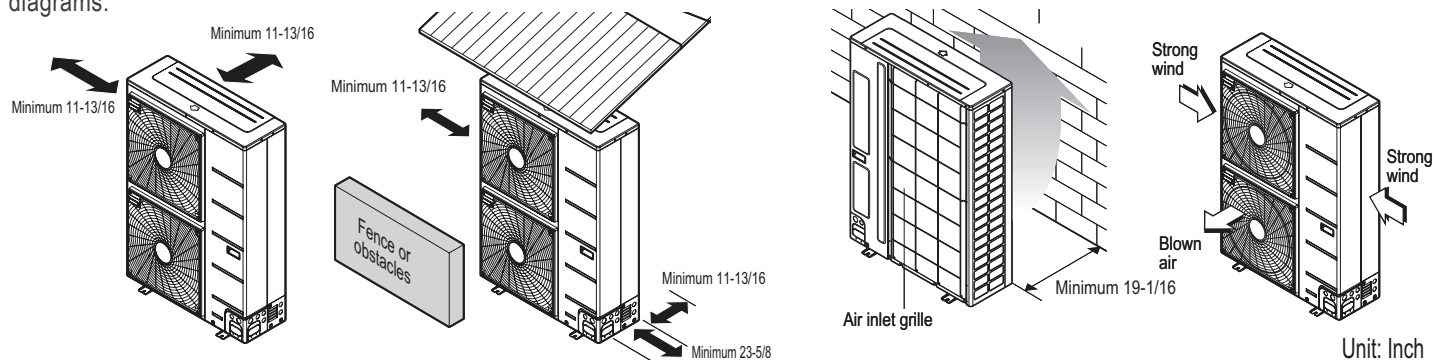
If the building does not include lightning protection, the outdoor unit may be damaged from a lightning strike. Inform the customer of this possibility in advance.

Outdoor Unit Service Access and Allowable Clearances

Appropriate airflow through the outdoor unit coil is critical for proper unit operation.

- Include enough space for airflow and for service access. If installing multiple outdoor units, avoid placing the units where the discharge of one unit will blow into the inlet side of an adjacent unit.
- No obstacles to air circulation around the unit; keep proper distances from ceilings, fences, floor, walls, etc. (Install a fence to prevent pests from damaging the unit or unauthorized individuals from accessing it.)
- If an awning is built over the unit to prevent direct sunlight or rain exposure, make sure that the discharge air of the outdoor unit isn't restricted.

When installing the outdoor unit, consider service, inlet, and outlet, and minimum allowable space requirements as illustrated in the following diagrams.

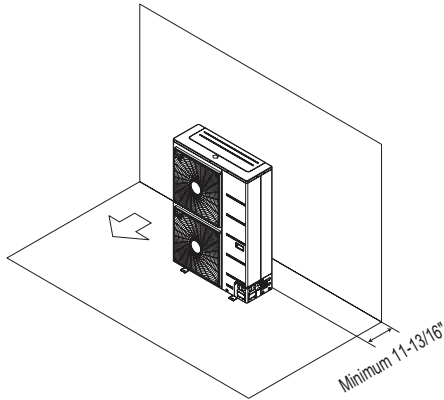


Ensure that the space at the back of the outdoor unit is a minimum of 11-13/16 inches, and include a minimum of 23-5/8 inches at the right side of the unit for service.

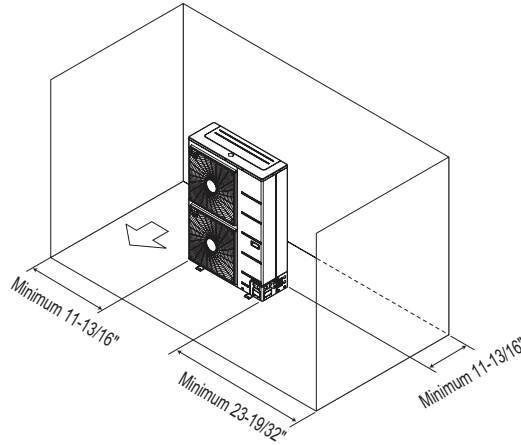
If the outdoor unit discharge side faces a wall, include a minimum of 19-11/16 inches between the outdoor unit and the wall. Install the outdoor unit so that the discharge port is set at a right angle to the wind direction.

Clearance Requirements when Different Obstacles are Present (Unit: Inch).

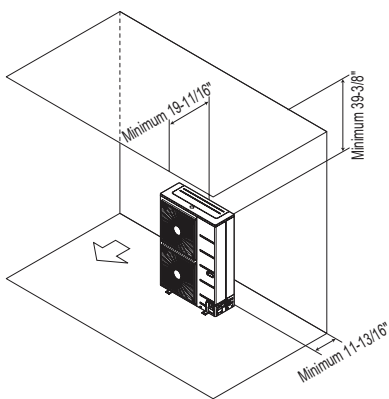
Obstacle on the suction side only.



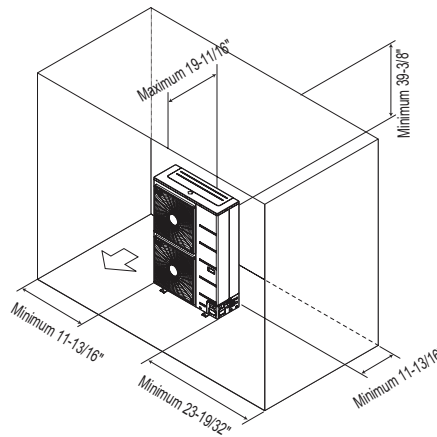
Obstacles on the suction side and on both left and right sides.



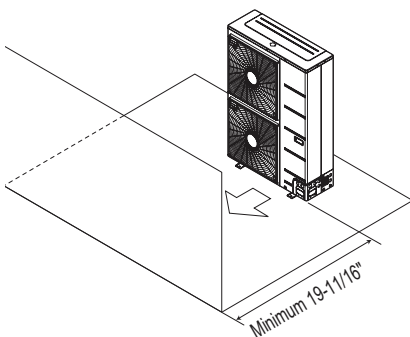
Obstacles above and on the air intake side.



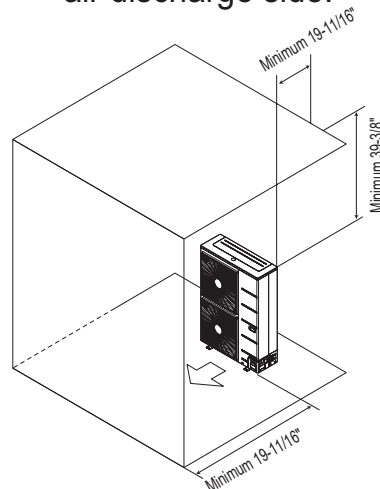
Obstacles above, on the air intake side, and on both left and right sides



Obstacle just on the air discharge side.



Obstacles above and on the air discharge side.

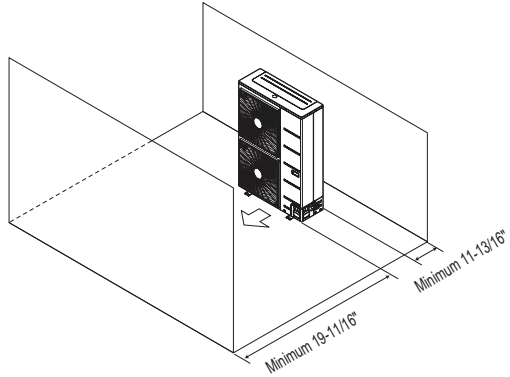


PLACEMENT CONSIDERATIONS

MULTI F
MULTI F MAX

Clearance Requirements when Different Obstacles are Present, continued. (Unit: Inch)

Where there are obstacles on both suction and discharge sides (discharge side obstacle is higher than the outdoor unit).



Where there are obstacles above, and on both suction and discharge sides (discharge side obstacle is higher than the outdoor unit).

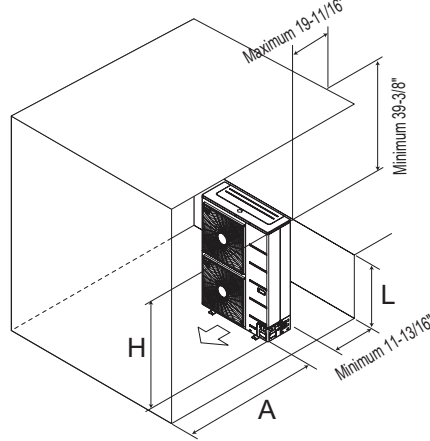
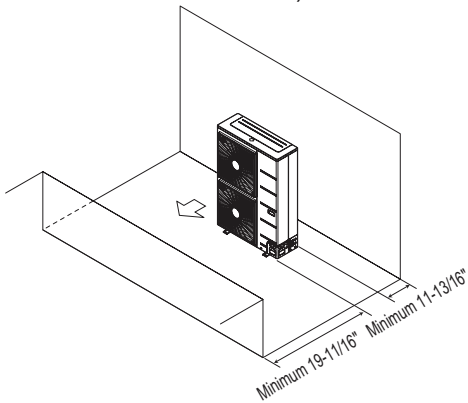


Table 105: Ratio among H, A, and L.

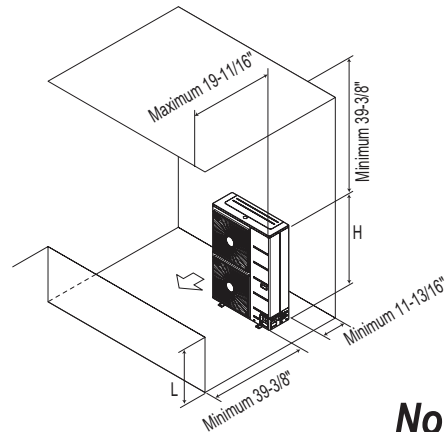
	L	A
L ≤ H	0 < L ≤ 1/2 H	29-1/32 inches
	1/2 H < L	39-3/8 inches
H < L	Set Stand as: L ≤ H	

If a stand is necessary, it should be contained (not open frame) to prevent the discharge air from short cycling.

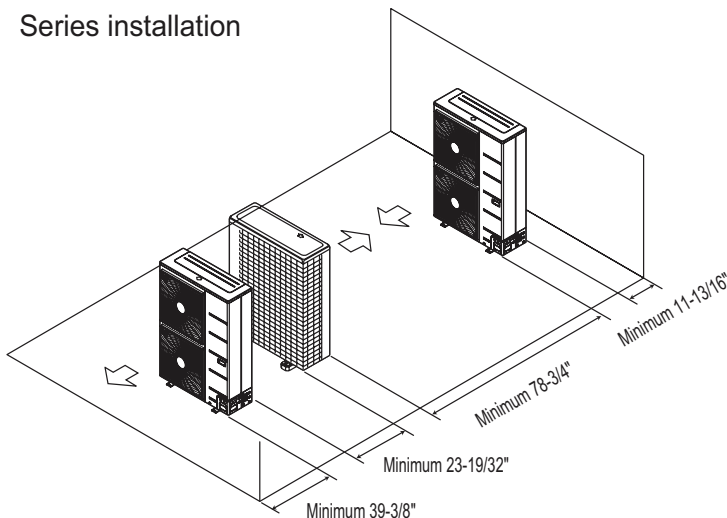
Where there are obstacles on both suction and discharge sides (discharge side obstacle is lower than the outdoor unit).



Where there are obstacles above, and on both suction and discharge sides (discharge side obstacle is lower than the outdoor unit).



Series installation



Note:

"L" should be lower than "H". If a stand is necessary, it should be contained (not open frame) to prevent the discharge air from short cycling.

REFRIGERANT PIPING DESIGN & LAYOUT BEST PRACTICES

“Design Guideline Summary” on page 192

“Creating a Balanced / Quality Piping System” on page 194

“Manual Layout Procedure” on page 194

“LG Engineered Multi F MAX Y-Branch Kits” on page 195

“Refrigerant Charge” on page 196

“Selecting Field-Supplied Copper Tubing” on page 198

“Refrigerant Piping System Layout” on page 200

“Piping Insulation” on page 208

“Condensate Drain Piping” on page 209

“Cut Sheet” on page 211

REFRIGERANT PIPING DESIGN

MULTI F
MULTI F MAX

Design Guideline Summary

The following are examples of manual pipe size calculations. Designers are highly encouraged to use LATS for Multi F systems.

Device Connection Limitations

- The minimum number of connected and operating indoor units to Multi F / Multi F MAX systems is two, taking into consideration of the minimum combination ratio.
- The maximum number of indoor units for each Multi F / Multi F MAX heat pump systems is:

LMU18CHV = 2 LMU24CHV = 3 LMU36CHV = 4 LMU540HV = 8

One of the most critical elements of multi-zone systems is the refrigerant piping. The following pages list pipe length limits that must be followed in the design of Multi F and Multi F MAX refrigerant pipe systems:

Using Refrigerant Components

Field-supplied elbows are allowed as long as they are designed for use with R410A refrigerant. The designer, however, should be cautious with the quantity and size of fittings used, and must account for the additional pressure losses in equivalent pipe length calculation for each branch. The equivalent pipe length of each elbow must be added to each pipe segment.

Table 106: Equivalent Piping Length for Elbows, Y-branches, and Branch Distribution Units.

Component	Size (Inches)				
	1/4	3/8	1/2	5/8	3/4
Elbow (ft.)	0.5	0.6	0.7	0.8	1.2
Y-Branch Kit (ft., Multi F MAX systems only) ¹	1.6				
Branch Distribution Unit (ft., Multi F MAX systems only)	8.2				

¹Kit contains two Y-branches: one for liquid and one for vapor.

Multi F System

Example: LMU36CHV outdoor unit with four (4) indoor units connected.

ODU: Outdoor Unit.

IDU: Indoor Unit.

A, B, C, D: Pipes from Outdoor Unit to Indoor Unit.

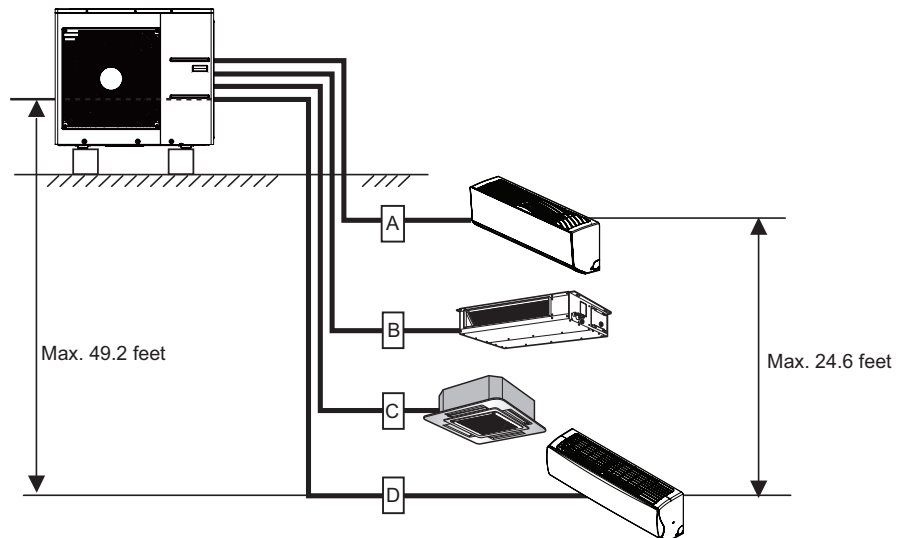


Table 107: Multi F Outdoor Unit Refrigerant Piping System Limitations.

Outdoor Unit	Minimum Length for Each Pipe (ft.)	Maximum Piping Length to Each Indoor Unit (ft.)				Maximum Total Piping Length for Each System (ft.)
		A	B	C	D	
LMU18CHV	10	82	82	-	-	164
LMU24CHV	10	82	82	82	-	246.1
LMU36CHV	10	82	82	82	82	246.1

The following are examples of manual pipe size calculations. Designers are highly encouraged to use LATS for Multi F systems.

Multi F MAX System with One Branch Distribution Unit

Example: LMU540HV outdoor unit with four (4) indoor units, and one (1) branch distribution unit connected.

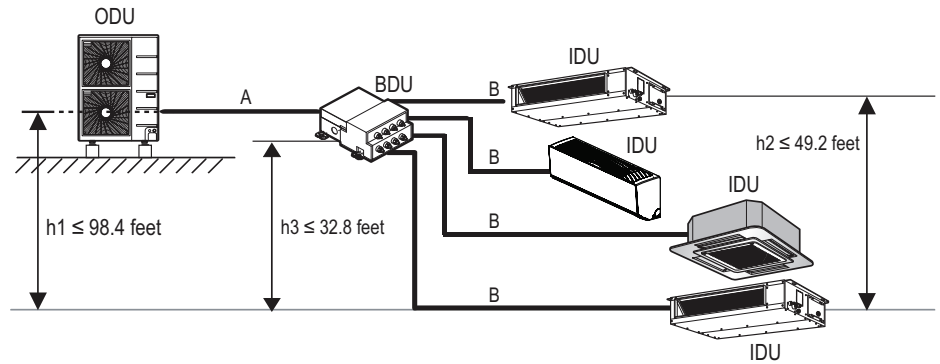
ODU: Outdoor Unit.

IDU: Indoor Unit.

BDU: Branch Distribution Unit.

A: Main Pipe.

B: Branch Pipe (Branch Distribution Unit to Indoor Unit[s]).



Multi F MAX System with Two Branch Distribution Units

Example: LMU540HV outdoor unit with seven (7) indoor units, and two (2) branch distribution units connected.

ODU: Outdoor Unit.

IDU: Indoor Unit.

BD: Branch Distribution Unit(s).

ΣA : Main Pipe.

ΣB : Branch Pipe (Branch Distribution Unit[s] to Indoor Unit[s]).

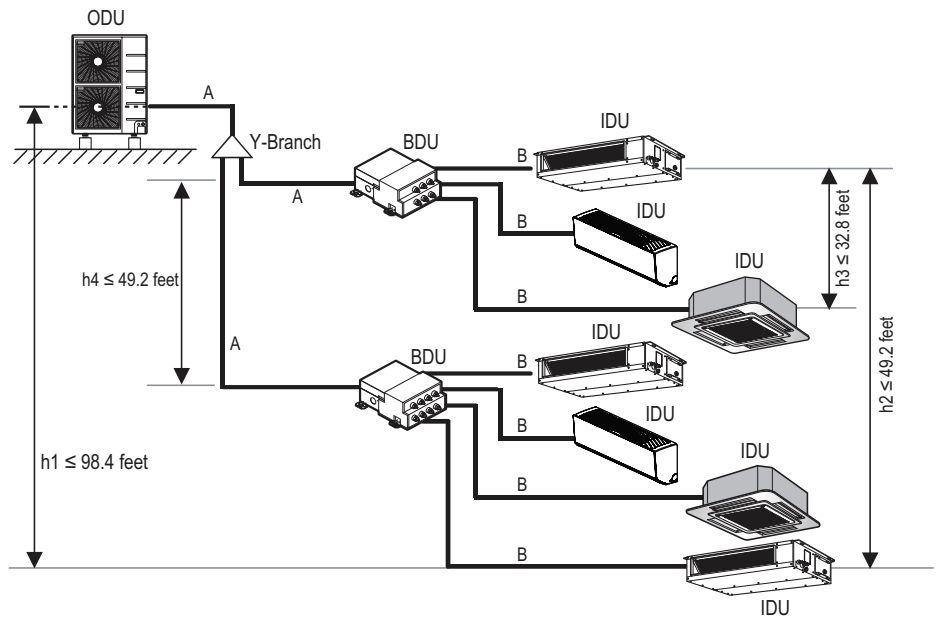


Table 108: Multi F MAX Outdoor Unit Refrigerant Piping System Limitations.

Pipe Length (ELF = Equivalent Length of pipe in Feet)	Total piping length ($\Sigma A + \Sigma B$)		≤475.7 feet
	Main pipe (Outdoor Unit to Branch Distribution Units: ΣA)	Minimum	10 feet
		Maximum	≤180.4 feet
	Total branch piping length (ΣB)		≤295.3 feet
Branch pipe (Branch Distribution Units to Indoor Units: B)	Minimum	10 feet	
	Maximum	≤49.2 feet	
Elevation Differential (All Elevation Limitations are Measured in Actual Feet)	If outdoor unit is above or below indoor unit (h_1)	≤98.4 feet	
	Between the farthest two indoor units (h_2)	≤42.9 feet	
	Between branch distribution unit and farthest connected indoor unit(s) (h_3)	≤32.8 feet	
	Between branch distribution units (h_4)	≤42.9 feet	

Table 109: Multi F MAX Piping Sizes.

Piping	Main Pipe A (inch)	Branch Pipe B
Liquid	Ø3/8	Depends on the size of the indoor unit piping
Gas	Ø3/4	

Creating a Balanced / Quality Piping System

Unlike designing duct-work or chilled and hot water pipe systems where balancing dampers, ball valves, orifices, circuit setters, or other flow control devices can be installed to modify or balance the flow of cooling medium, these cannot be used in a Multi F system. Therefore, variable refrigerant flow systems have to be designed to be “self balanced.” Balanced liquid refrigerant distribution is solely dependent on the designer using the correct pipe size for each segment. Pipe sizing considerations include pipe length, pipe segment pressure drop relative to other pipe segments in the system, type and quantity of elbows, bends present, fitting installation orientation, and end use device elevation differences.

Note:

The designer should avoid creating excessive pressure drop. When liquid refrigerant is subjected to excessive pressure drop, liquid refrigerant will change state and “flash” to vapor. Vapor present in a stream of liquid refrigerant before reaching the indoor unit coil (or branch distribution unit for Multi F MAX systems) results in a loss of system control and causes damage to the components. The pipe system must be designed in a manner that avoids the creation of unwanted vapor.

Refrigerant Piping System Verification

To ensure that the refrigerant piping design is suitable for the system, a LATS refrigerant piping design software report must be provided with every Multi F order. Following the installation, if any changes or variations to the design were necessary, an “as-built” LATS piping design software report must be provided to LG prior to system commissioning. User should always check the LATS report actual pipe layout versus pipe limits.

Note:

Any field changes, such as re-routing, shortening or lengthening a pipe segment, adding or eliminating elbows and/or fittings, re-sizing, adding, or eliminating indoor units, changing the mounting height or moving the location of a device or fitting during installation should be done with caution and ALWAYS VERIFIED in LATS MULTI F SOFTWARE before supplies are purchased or installed. Doing so ensures profitable installation, eliminates rework, and ensures easier system commissioning.

Manual Layout Procedure

1. Choose the location of the indoor units on the building drawing.
2. Choose the location of all Y-branch and branch distribution units (if a Multi F MAX system) and note them on the building drawing. Verify that all fittings are positioned per the guideline limitations in “LG Engineered Multi F MAX Y-Branch Kit” on page 195.
3. Plan the route for interconnecting piping. Draw a one-line depiction of the pipe route chosen on the building drawing.
4. Calculate the actual length of each pipe segment and note it on the building drawing.
5. Using the data obtained while selecting the system components, list the corrected cooling capacity next to each indoor unit on the drawing.
6. Starting at the indoor unit located farthest from the outdoor unit, sum the corrected cooling capacity of all indoor units served by the pipe segment for each branch and runout pipe (indoor units and branch distribution units [Multi F MAX systems only]). Record these values next to each segment.
7. Verify the size of the liquid and vapor lines.
8. If a Multi F MAX system, refer to the branch distribution unit information on page 205 and the Y-branch kit information on page 211 to verify the part number of each Y-branch and branch distribution unit based on the connected downstream nominal capacity served.
9. Calculate the equivalent pipe length in feet of each pipe segment. If a Multi F MAX system, Y-branch equivalent lengths should be totaled with the upstream segment only. Use equivalent pipe length data when it is provided with field-purchased fittings. If not available, use the data provided in Table 106 on page 192 to estimate the equivalent length of field-provided pipe and fittings for each segment. Equivalent lengths should be totaled with the upstream segment only.
10. For Multi F systems, verify the equivalent pipe length complies with the limitations in Table 107 on page 192. For Multi F MAX systems, verify the equivalent pipe length complies with the limitations in Table 108 on page 193. If the limitations are exceeded, either reroute the pipe or change the location of the indoor unit, Y-branch fittings and branch distribution units (if Multi F MAX systems), so the design conforms with all limitations.
11. If pipe length is adjusted as described in Step 10 above, verify again if the length of the design complies with the limitations in Table 107 (Multi F) or Table 108 (Multi F MAX).
12. Use LATS Multi F software to verify the manually sized pipe design is acceptable. When entering the length of pipe segments in LATS Multi F software, enter the equivalent pipe length. Account for the additional pressure drop created by elbows, valves, and other fittings present in each segment by adding their respective equivalent pipe length to the actual pipe length.

Multi F MAX Y-Branch Kit PMBL5620

The LG supplied Y-Branch Kit PMBL5620 MUST be used when two branch distribution units are connected on one Multi F MAX system. Field-supplied fittings are not permitted. Each Y-Branch kit comes with two (2) Y-branches (one for the liquid line and one for the vapor line) and insulation covers.

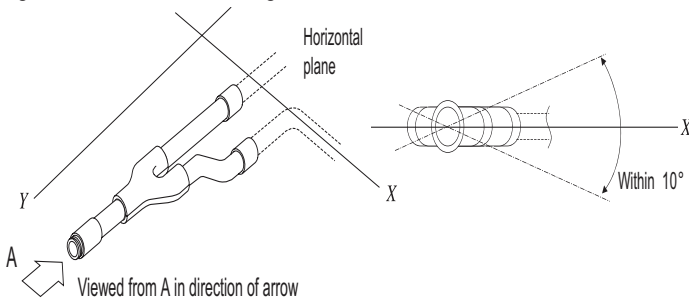
Y-branches may be installed in horizontal or vertical configurations. When installed vertically, position the Y-branch so the straight-through leg is $\pm 3^\circ$ of plumb. When installed horizontally, position the Y-branch so the take-off leg is level and shares the same horizontal plane as the straight-through leg $\pm 10^\circ$ rotation.

Y-branches must be properly installed following instructions in the applicable LG manual. Y-branches should always be installed with the single port facing the outdoor unit and the two-port end facing the branch distribution units. Do not install Y-branches backwards as refrigerant flow cannot make U-turns. The Y-branch kit must be located at least three (3) feet from the outdoor unit. Provide a minimum of 20 inches between a Y-branch and the branch distribution unit.

It is recommended that when a Y-branch is located in a pipe chase or other concealed space, access doors should be provided for inspection access.

The equivalent pipe length of each Y-branch (1.6') must be added to the main pipe segment entered into LATS piping design software.

Figure 259: Horizontal Configuration End View.



Y-Branch Kit Insulation

Each Y-branch kit comes with clam-shell type peel-and-stick insulation jackets molded to fit the Y-branch fittings—one for the liquid line, one for the vapor line.

- Check the fit of the Y-branch clam-shell insulation jacket after the Y-branch is installed.
- Mark the pipe where the insulation jacket ends.
- Remove the jacket.
- Install field-provided insulation on the pipes first.
- Peel the adhesive glue protector slip and install the clam-shell jacket over the fitting

Figure 257: Y-Branch Connections.

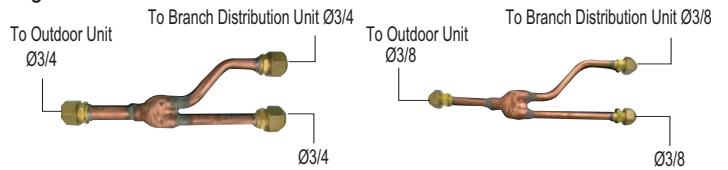
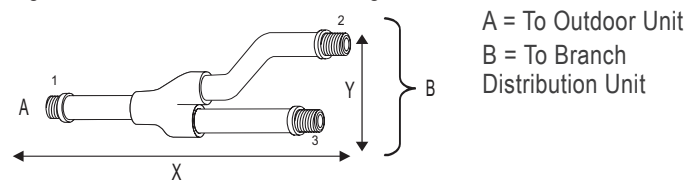


Table 110: Y-Branch Connection Diameters.

Model	Y-Branch Type	Port Identifier (inch)			Dimensions	
		1	2	3	X	Y
PMBL5620	Liquid	3/8	3/8	3/8	13.80	3.24
	Vapor	3/4	3/4	3/4	12.48	3.02

Figure 258: Y-Branch Dimensions Diagram.



Note:

- Design pressure is 551 psig.
- All dimensions in inches. Tolerance $\pm 1/4$ inch.
- Images are not to scale.

Figure 260: Y-branch Installation Alignment Specification.

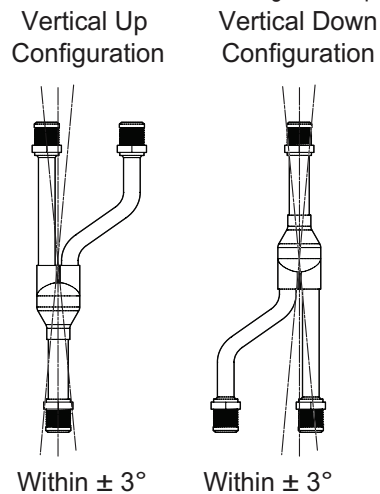
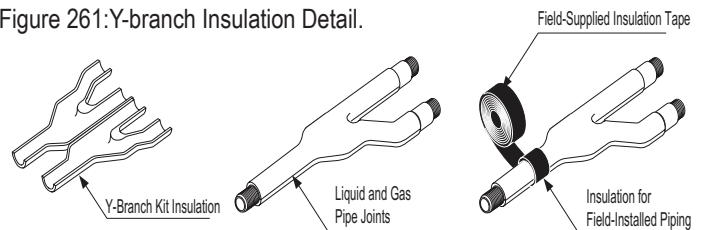


Figure 261: Y-branch Insulation Detail.



REFRIGERANT PIPING DESIGN

Refrigerant Charge

MULTI F
MULTI F MAX

LG Multi F and Multi F MAX outdoor units ship from the factory with a charge of R410A refrigerant. A trim charge may need to be added to take into account additional piping length.

To determine the additional refrigerant that is needed, apply the formulas below, and record the results. If the total additional refrigerant charge value is a negative number, then an additional trim charge does not need to be added to the system.

Table 111: Outdoor Unit Factory Charge.

Outdoor Unit	Factory Charge lbs. of R410A
LMU18CHV	3.96
LMU24CHV	3.96
LMU36CHV	6.18
LMU540HV	9.7

Multi F Systems

$$\begin{aligned} \text{Additional charge (lbs.)} &= (\text{Installed Length of Branch [A]} - \text{Chargeless Pipe Length [L]}) \times a \\ &+ (\text{Installed Length of Branch [B]} - \text{Chargeless Pipe Length [L]}) \times a \\ &+ (\text{Installed Length of Branch [C]} - \text{Chargeless Pipe Length [L]}) \times a \\ &+ (\text{Installed Length of Branch [D]} - \text{Chargeless Pipe Length [L]}) \times a \\ &- CF (\text{Correction Factor}) \times 5.29 \end{aligned}$$

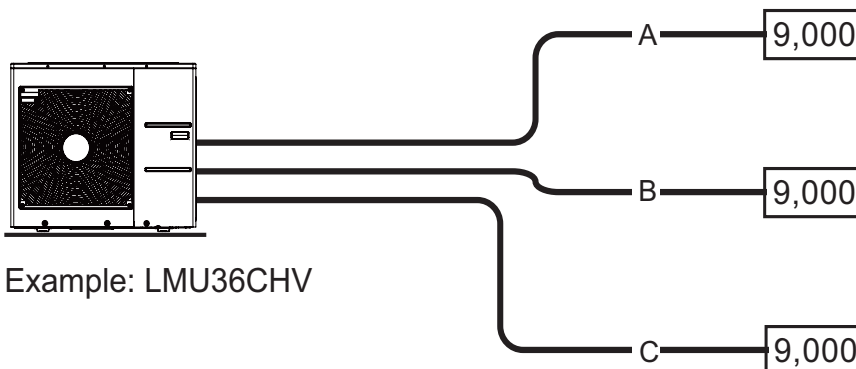
Note:

- Number of installed length of branches depends on the specifications of the outdoor unit model.
- CF = Maximum number of connectable indoor units – Total number of connected indoor units.

Table 112: Multi F Outdoor Unit Piping Specifications.

Outdoor Unit Model	Min. to Max. Piping Length for One Branch (ft.)	Max. Total System Piping Length (ft.)	Chargeless Pipe Length per Branch (L) (ft.)	Additional Charge Needed (a) (oz./ft.)
LMU18CHV	10 to 82	164	24.6	0.22
LMU24CHV	10 to 82	246.1	24.6	0.22
LMU36CHV	10 to 82	246.1	24.6	0.22

Figure 262: Multi F Additional Refrigerant Charge Example.



Example: LMU36CHV

Each branch pipe
A = 82 ft.
B = 16 ft.
C = 49 ft.

$$\begin{aligned} \text{Additional Charge} &= (82 - 24.6) \times 0.22 \\ &+ (16 - 24.6) \times 0.22 \\ &+ (49 - 24.6) \times 0.22 \\ &- (4 - 3) \times 5.29 \\ &= 10.82 \text{ oz.} \end{aligned}$$

Multi F MAX Systems

Additional charge (lbs.) = (Total Main Piping Length [A] - Chargeless Pipe Length of Main Pipe [L]) x a
 + (Installed Length of Branch [B1] - Chargeless Pipe Length [B]) x b
 + (Installed Length of Branch [B2] - Chargeless Pipe Length [B]) x b
 + (Installed Length of Branch [B3] - Chargeless Pipe Length [B]) x b ...
 - CF (Correction Factor) x 3.53

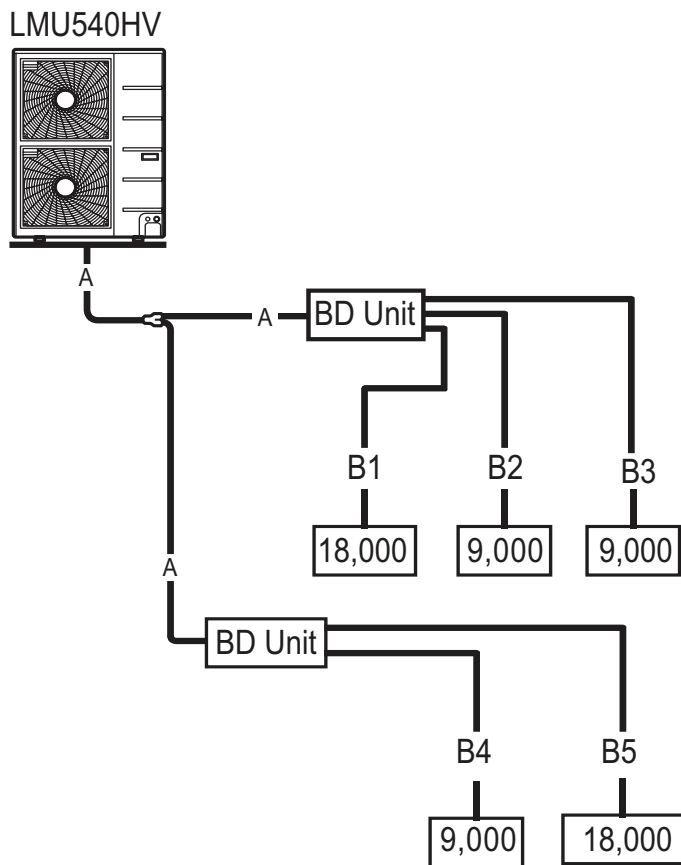
Note:

- Number of installed length of branches depends on system specifications.
- CF = Maximum number of connectable indoor units - Total number of connected indoor units

Table 113: Multi F MAX Outdoor Unit Piping Specifications.

Outdoor Unit Model	Main Piping Length		Branch Piping Length	
	Chargeless Pipe Length of Main Pipe (L) (ft.)	Additional Charge Needed (a) (oz./ft.)	Chargeless Pipe Length per Branch Pipe (B) (ft.)	Additional Charge Needed (b) (oz./ft.)
LMU540HV	16.4	0.54	16.4	0.22

Figure 263: Multi F MAX Additional Refrigerant Charge Example.



- Total main pipe (A) = 60 ft.
- Each branch pipe
 B1 = 49 ft.
 B2 = 17 ft.
 B3 = 17 ft.
 B4 = 10 ft.
 B5 = 23 ft.

Additional Charge
 = (60 - 16.4) x 0.54
 + (49 - 16.4) x 0.22
 + (17 - 16.4) x 0.22
 + (17 - 16.4) x 0.22
 + (10 - 16.4) x 0.22
 + (23 - 16.4) x 0.22
 - (8 - 5) x 3.53
 = 20.43 oz.

REFRIGERANT PIPING DESIGN

Selecting Field-Supplied Copper Tubing

MULTI F
MULTI F MAX

Type ACR copper is the only approved refrigerant pipe material for use with LG Multi F air conditioning products. ACR rated tubing is the only type that ships with yellow caps. Approved tubing for use with Multi V products will be marked “R410 RATED” along the length of the tube.

- Drawn temper (rigid) ACR copper tubing is available in sizes 3/8 through 2-1/8 inches (ASTM B 280, clean, dry, and capped).

- Annealed temper (soft) ACR copper tubing is available in sizes 1/4 through 2-1/8 inches (ASTM B 280, clean, dry, and capped).

Tube wall thickness should meet local code requirements and be approved for a maximum operating pressure of 551 psi. When bending tubing, use the largest radii possible to reduce the equivalent length of installed pipe; also, bending radii greater than ten (10) pipe diameters can minimize pressure drop. Be sure no traps or sags are present when rolling out soft copper tubing coils.

Table 114: ACR Rated Copper Tubing Material.

Type	Seamless Phosphorous Deoxidized
Class	UNS C12200 DHP
Straight Lengths	H58 Temper
Coils	O60 Temper

Table 115: ACR Rated Piping Tube Thicknesses.

OD (in)	1/4	3/8	1/2	5/8	3/4
Material	Rigid or Soft ACR Acceptable			Rigid or Solid ACR Rated for R410A	
Min. Bend Radius (in)	.563	.9375	1.5	2.25	3.0
Min. Wall Thickness (in)	.031	.031	.031	.039	.039

Copper Expansion and Contraction

Under normal operating conditions, the vapor pipe temperature of a Multi F system can vary as much as 180°F. With this large variance in pipe temperature, the designer must consider pipe expansion and contraction to avoid pipe and fitting fatigue failures. Refrigerant pipe, along with the insulation jacket, form a cohesive unit that expands and contracts together. During system operation, thermal heat transfer occurs between the pipe and the surrounding insulation.

If the pipe is mounted in free air space, no natural restriction to movement is present if mounting clamps are properly spaced and installed. When the refrigerant pipe is mounted underground in a utility duct stacked among other pipes, natural restriction to linear movement is present. In extreme cases, the restrictive force of surface friction between insulating jackets could become so great that natural expansion ceases and the pipe is “fixed” in place. In this situation, opposing force caused by change in refrigerant fluid/vapor temperature can lead to pipe/fitting stress failure.

The refrigerant pipe support system must be engineered to allow free expansion to occur. When a segment of pipe is mounted between two fixed points, provisions must be provided to allow pipe expansion to naturally occur. The most common method is the inclusion of expansion Loop or U-bends mounted in the horizontal plane. When expansion loops are placed in a vertical riser, the loop is to be formed in a horizontal fashion resulting in a torsional movement during expansion and contraction. Each segment of pipe has a natural fixed point where no movement occurs. This fixed point is located at the center point of the segment assuming the entire pipe is insulated in a similar fashion. The natural fixed point of the pipe segment is typically where the expansion Loop or U-bend should be. Linear pipe expansion can be calculated using the following formula:
 $LE = C \times L \times (T_r - T_a) \times 12$

- LE = Anticipated linear tubing expansion (in.)
- C = Constant (For copper = 9.2×10^{-6} in./in.°F)
- L = Length of pipe (ft.)
- T_r = Refrigerant pipe temperature (°F)
- T_a = Ambient air temperature (°F)
- 12 = Inches to feet conversion (12 in./ft.)

1. From Table 115, find the row corresponding with the actual length of the straight pipe segment.
2. Estimate the minimum and maximum temperature of the pipe. Typical pipe temperature change range: High Pressure Vapor: ambient temperature to 215°F; Low Pressure Vapor: ambient to 35°F; Liquid pipe: ambient, 80°F, 110°F. Choose the two most extreme. In the column showing the minimum pipe temperature, look up the anticipated expansion distance. Do the same for the maximum pipe temperature.
3. Calculate the difference in the two expansion distance values. The result will be the anticipated change in pipe length.

Example:

A Multi F MAX system is installed and the design shows that there is a 100 foot straight segment of tubing between a Y-branch and a branch distribution unit. The system operates 24 hours per day. In heating, this pipe transports hot gas vapor to the indoor units at 120°F. In cooling, the same tube is a suction line returning refrigerant vapor to the outdoor unit at 40°F. Look up the copper tubing expansion at each temperature and calculate the difference.

Vapor Line

Transporting Hot Vapor: 100 ft. pipe at 120°F = 1.40 in.
 Transporting Suction Vapor: 100 ft. pipe at 40°F = 0.40 in.
 Anticipated Change in Length: 1.40 in. – 0.40 in. = 1.00 in.

Liquid Line

The liquid temperature remains the same temperature; only the direction of flow will reverse. Therefore, no significant change in length of the liquid line is anticipated.

When creating an expansion joint, the joint depth should be a minimum of two times the joint width. Although different types of expansion arrangements are available, the data for correctly sizing an expansion loop is provided in Table 117. Use soft copper with long radius bends on longer runs or long radius elbows for shorter pipe segments. Using the anticipated linear expansion (LE) distance calculated, look up the Expansion Loop or U-bend minimum design dimensions. If other types of expansion joints are chosen, design per ASTM B-88 Standards.

Table 116: Linear Thermal Expansion of Copper Tubing in Inches.

Pipe Length ¹	Fluid Temperature °F																			
	35°	40°	45°	50°	55°	60°	65°	70°	75°	80°	85°	90°	95°	100°	105°	110°	115°	120°	125°	130°
10	0.04	0.04	0.05	0.06	0.06	0.07	0.08	0.08	0.09	0.09	0.10	0.10	0.11	0.11	0.11	0.12	0.13	0.14	0.15	0.15
20	0.08	0.08	0.10	0.12	0.13	0.14	0.15	0.16	0.17	0.18	0.19	0.20	0.21	0.22	0.22	0.23	0.26	0.28	0.29	0.30
30	0.12	0.12	0.15	0.18	0.20	0.21	0.23	0.24	0.26	0.27	0.29	0.30	0.32	0.33	0.32	0.35	0.39	0.42	0.44	0.45
40	0.16	0.16	0.20	0.24	0.26	0.28	0.30	0.32	0.34	0.36	0.38	0.40	0.42	0.44	0.43	0.46	0.52	0.56	0.58	0.60
50	0.20	0.20	0.25	0.30	0.33	0.35	0.38	0.40	0.43	0.45	0.48	0.50	0.53	0.55	0.54	0.58	0.65	0.70	0.73	0.75
60	0.24	0.24	0.30	0.36	0.39	0.42	0.45	0.48	0.51	0.54	0.57	0.60	0.63	0.66	0.65	0.69	0.78	0.84	0.87	0.90
70	0.28	0.28	0.35	0.42	0.46	0.49	0.53	0.56	0.60	0.63	0.67	0.70	0.74	0.77	0.76	0.81	0.91	0.98	1.02	1.05
80	0.32	0.32	0.40	0.48	0.52	0.56	0.60	0.64	0.68	0.72	0.76	0.80	0.84	0.88	0.86	0.92	1.04	1.12	1.16	1.20
90	0.36	0.36	0.45	0.54	0.59	0.63	0.68	0.72	0.77	0.81	0.86	0.90	0.95	0.99	0.97	1.04	1.17	1.26	1.31	1.35
100	0.40	0.40	0.50	0.60	0.65	0.70	0.75	0.80	0.85	0.90	0.95	1.00	1.05	1.10	1.08	1.15	1.30	1.40	1.45	1.50
120	0.48	0.48	0.60	0.72	0.78	0.84	0.90	0.96	1.02	1.08	1.14	1.20	1.26	1.32	1.30	1.38	1.56	1.68	1.74	1.80
140	0.56	0.56	0.70	0.84	0.91	0.98	1.05	1.12	1.19	1.26	1.33	1.40	1.47	1.54	1.51	1.61	1.82	1.96	2.03	2.10
160	0.64	0.64	0.80	0.96	1.04	1.12	1.20	1.28	1.36	1.44	1.52	1.60	1.68	1.76	1.73	1.84	2.08	2.24	2.32	2.40
180	0.72	0.72	0.90	1.08	1.17	1.26	1.35	1.44	1.53	1.62	1.71	1.80	1.89	1.98	1.94	2.07	2.34	2.52	2.61	2.70

¹Pipe length baseline temperature = 0°F. "Expansion of Carbon, Copper and Stainless Steel Pipe," *The Engineers' Toolbox*, www.engineeringtoolbox.com.

Figure 264: Coiled Expansion Loops and Offsets (Plan View shown).

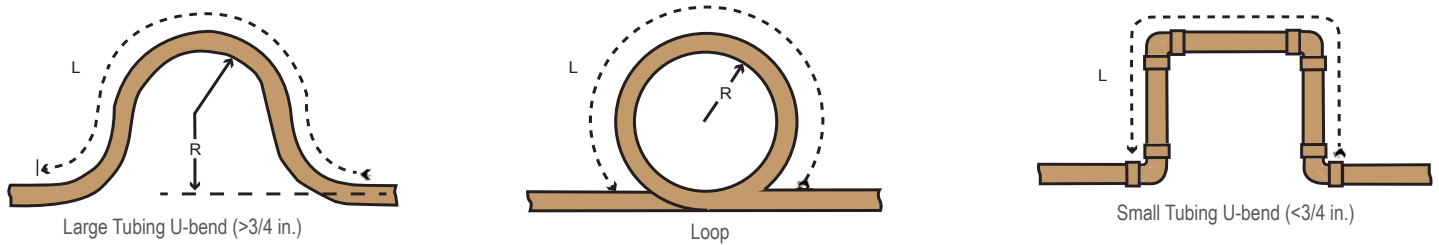


Table 117: Radii of Coiled Expansion Loops and Developed Lengths of Expansion Offsets.

Anticipated Linear Expansion (LE) (inches)		Nominal Tube Size (OD) inches			
		1/4	3/8	1/2	3/4
1/2	R ¹	6	7	8	9
	L ²	38	44	50	59
1	R ¹	9	10	11	13
	L ²	54	63	70	83
1-1/2	R ¹	11	12	14	16
	L ²	66	77	86	101
2	R ¹	12	14	16	19
	L ²	77	89	99	117
2-1/2	R ¹	14	16	18	21
	L ²	86	99	111	131
3	R ¹	15	17	19	23
	L ²	94	109	122	143
3-1/2	R ¹	16	19	21	25
	L ²	102	117	131	155
4	R ¹	17	20	22	26
	L ²	109	126	140	166

¹R = Centerline Length of Pipe.

²L = Centerline Minimum Radius (inches).

Note:

All expansion Loops and Offsets should be installed in the horizontal plane to prevent the possibility of trapping oil. Loops and Offsets in vertical risers should also be installed in a horizontal plane.

Field-Provided Isolation Ball Valves

LG recommends installing field-supplied ball valves with Schrader ports at each indoor unit. Full-port isolation ball valves with Schrader ports (positioned between valve and indoor unit) rated for use with R410A refrigerant should be used on both the liquid and vapor lines.

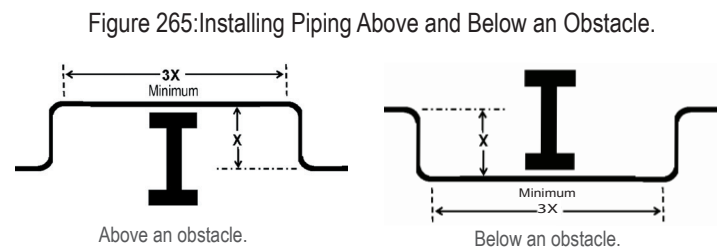
If valves are not installed and a single indoor unit needs to be removed or repaired, the entire system must be shut down and evacuated. If isolation ball valves are installed, and an indoor unit needs to be repaired, the unaffected indoor units can remain operational with the proper combination ratio. Reclamation of refrigerant, then, can be restricted to a single indoor unit.

For Multi F MAX systems, position valves with a minimum distance of three (3) to six (6) inches of pipe on either side of the valve, and placed between six (6) and twelve (12) inches from the first upstream Y-branch or branch distribution unit. If ball valves are installed away from the first Y-branch and / or branch distribution unit and closer to the indoor unit, oil may accumulate where it cannot be returned to the outdoor unit and may cause a shortage of oil in the compressor.

Valves shall be easily accessible for service. If necessary, install drywall access doors or removable ceiling panels, and position the valves to face the access door or ceiling panel opening. Mount valves with adequate space between them to allow for placement of adequate pipe insulation around the valves. Recommended best practice is to clearly label and document locations of all service valves, Y-branches, and branch distribution units. The equivalent pipe length of each ball valve must be added to each pipe segment entered into the LATS program.

Obstacles

When an obstacle, such as an I-beam or concrete T, is in the path of the planned refrigerant pipe run, it is best practice to route the pipe over the obstacle. If adequate space is not available to route the insulated pipe over the obstacle, then route the pipe under the obstacle. In either case, it is imperative the horizontal section of pipe above or below the obstacle be a minimum of three (3) times greater than the longest vertical rise (or fall) distance.



Pipe Slope

The horizontal pipe slope cannot exceed 10° up or down.

In-line Refrigeration Components

Components such as oil traps, solenoid valves, filter-dryers, sight glasses, tee fittings, and other after-market accessories are not permitted on the refrigerant piping system between the outdoor units and the indoor / branch distribution units. Multi F and Multi F MAX systems are provided with redundant systems that assure oil is properly returned to the compressor. Sight-glasses and solenoid valves may cause vapor to form in the liquid stream. Over time, dryers may deteriorate and introduce debris into the system. The designer and installer should verify the refrigerant piping system is free of traps, sagging pipes, sight glasses, filter dryers, etc.

No Pipe Size Substitutions

Use only the pipe size selected by the LATS Multi pipe system design software or as conveyed in the product installation instructions. Using a different size is prohibited and may result in a system malfunction or failure to work at all.

Inserts and Pipe Supports

Inserts

An insert can be installed into a floor or beam before the concrete sets so that fittings such as ducts, pipes, or suspension bolts can be added at a later time. Decide where the inserts should be placed before support installation.

Pipe Supports

Note:

A properly installed pipe system should be adequately supported to avoid pipe sagging. Sagging pipes become oil traps that lead to equipment malfunction.

Pipe supports should never touch the pipe wall; supports shall be installed outside (around) the primary pipe insulation jacket. Insulate the pipe first because pipe supports shall be installed outside (around) the primary pipe insulation jacket. Clevis hangers should be used with shields between the hangers and insulation.

Field provided pipe supports should be designed to meet local codes. If allowed by code, use fiber straps or split-ring hangers suspended from the ceiling on all-thread rods (fiber straps or split ring hangers can be used as long as they do not compress the pipe insulation). Place a second layer of insulation over the pipe insulation jacket to prevent chafing and compression of the primary insulation within the confines of the support pipe clamp.

A properly installed pipe system will have sufficient supports to avoid pipes from sagging during the life of the system. As necessary, place supports closer for segments where potential sagging could occur. Maximum spacing of pipe supports shall meet local codes. If local codes do not specify pipe support spacing, pipe shall be supported a maximum of 5 feet on center for straight segments of pipe up to 3/4" outside diameter size.

Wherever the pipe changes direction, place a hanger within twelve (12) inches on one side and within twelve to nineteen (12 to 19) inches of the bend on the other side. Support piping at indoor units as shown. Support Y-Branch fittings as shown.

Figure 269: Pipe Support at Indoor Unit.

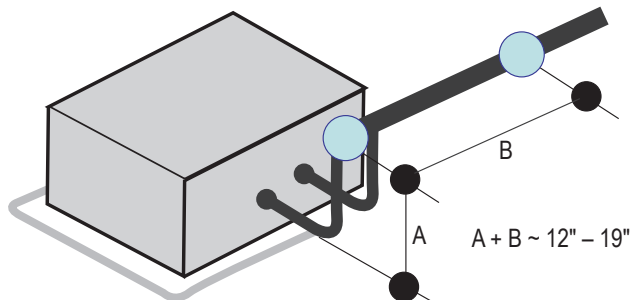


Figure 266: Installing an Insert Into a Concrete Beam.

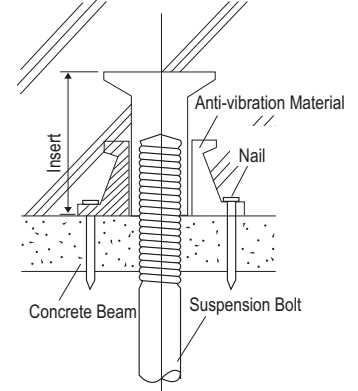


Figure 267: Pipe Hanger Details.

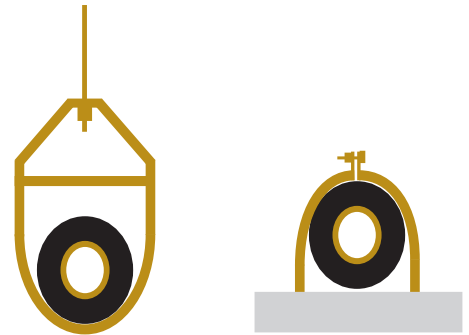


Figure 268: Typical Pipe Support Location—Change in Pipe Direction.

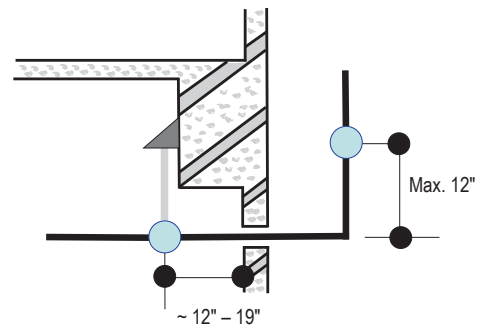
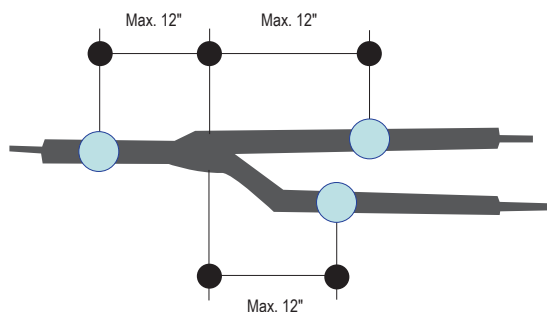


Figure 270: Pipe Support at Y-branch Fitting.



INSTALLATION & LAYOUT BEST PRACTICES

Refrigerant Piping System Layout

MULTI F
MULTI F MAX

Examples of Supports

Figure 271: U-Bolt Support with Insulation.

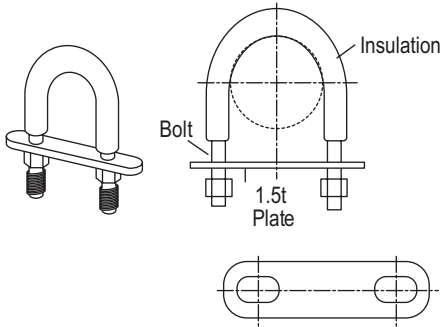


Figure 272: O-Ring Support with Insulation.

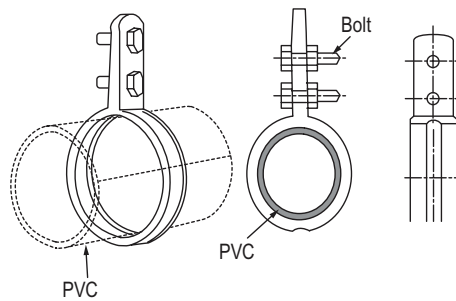
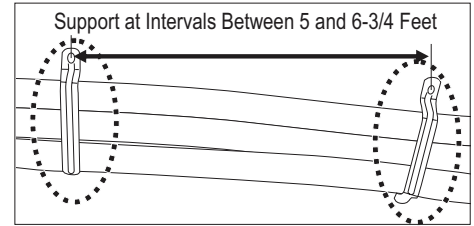


Figure 273: Saddle-Type Support.



Note:

Do not compress the insulation with the saddle-type support. If the insulation is compressed, it may tear open and allow condensation to generate during product operation.

Figure 274: U-Bolt Support with an Insulated Pipe.

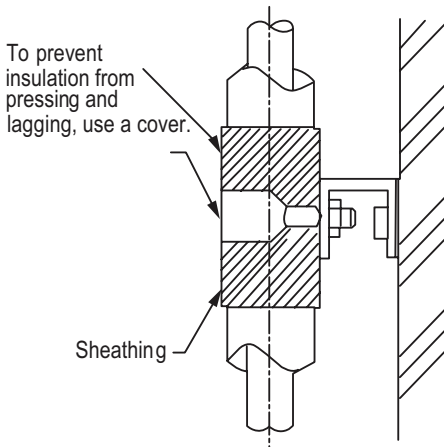


Figure 275: O-Ring Band Support with an Insulated Pipe.

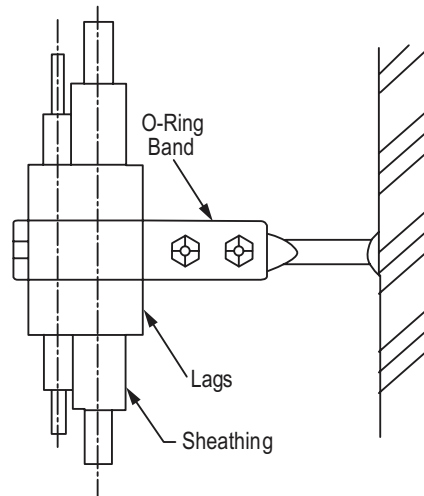


Figure 276: One-Point Down-Stop Support (>441 lbs.).

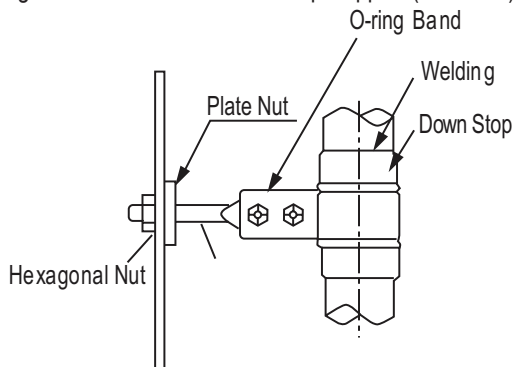
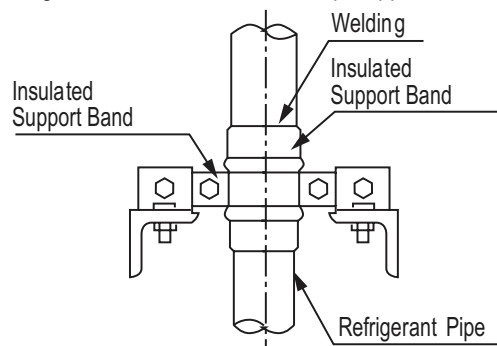


Figure 277: Two-Point Down-Stop Support.



Pipe Sleeves at Penetrations

LG requires that all pipe penetrations through walls, floors, and pipes buried underground be routed through a properly insulated sleeve that is sufficiently sized to provide free movement of the pipe and does not compress the insulation. Underground refrigerant pipe shall be routed inside a protective sleeve to prevent insulation deterioration. Also follow federal, state, and local regulations and codes when choosing a sleeve type.

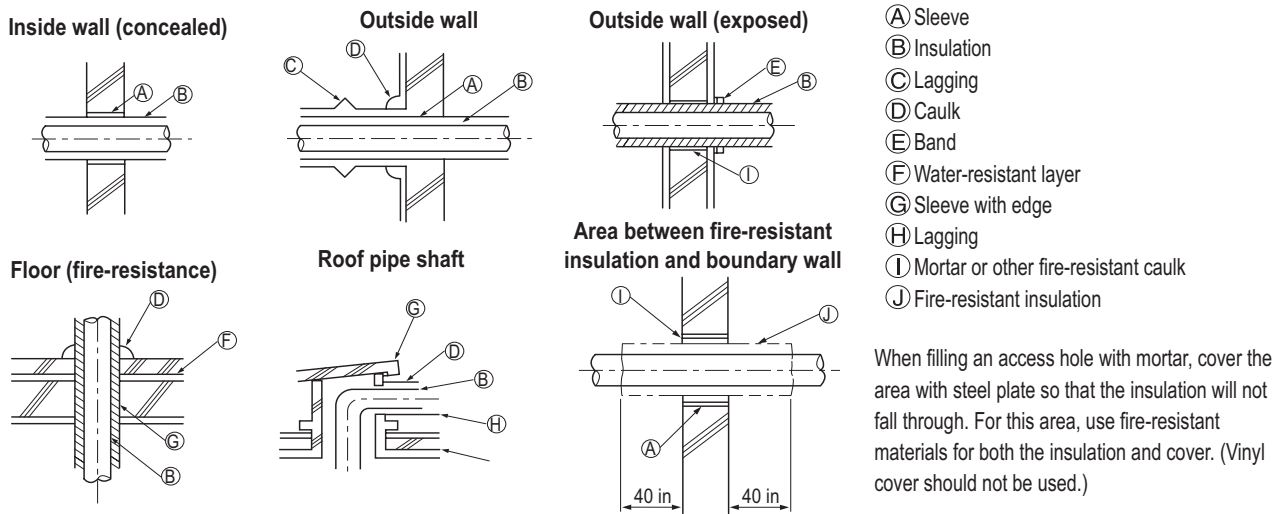
Note:

Diameter of penetrations shall be determined by pipe diameter plus the thickness of the insulation.

For example:

Diameter of Gas Piping:	1/2"
Diameter of Liquid Piping:	1/4"
Thickness of Gas Piping Insulation:	0.4" x 2
Thickness of Liquid Piping Insulation:	0.4" x 2
Surplus:	0.8"
Sleeve diameter (total):	3.1" minimum

Figure 278: Pipe Sleeve Options.



- Ⓐ Sleeve
- Ⓑ Insulation
- Ⓒ Lagging
- Ⓓ Caulk
- Ⓔ Band
- Ⓕ Water-resistant layer
- Ⓖ Sleeve with edge
- Ⓗ Lagging
- Ⓘ Mortar or other fire-resistant caulk
- ⓵ Fire-resistant insulation

When filling an access hole with mortar, cover the area with steel plate so that the insulation will not fall through. For this area, use fire-resistant materials for both the insulation and cover. (Vinyl cover should not be used.)

Underground Refrigerant Piping

Refrigerant pipe installed underground should be routed inside a vapor tight protective sleeve to prevent insulation deterioration and water infiltration. Refrigerant pipe installed inside underground casing must be continuous without any joints. Underground refrigerant pipe must be located at a level below the frost line.

Figure 279: Typical Arrangement of Refrigerant Pipe and Cable(s) in a Utility Conduit.

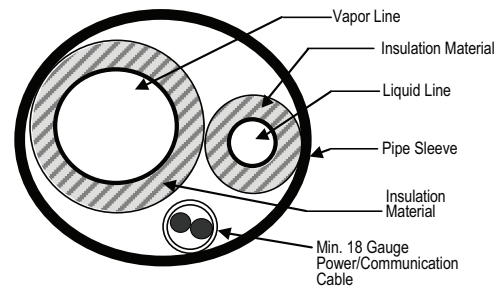


Figure 280: Underground Refrigerant Piping.



Table 118: Utility Conduit Sizes.

Liquid Pipe ¹	Vapor Pipe ¹		
	1/2 (2.0 ^{2,5})	5/8 (2-1/8 ^{2,5})	3/4 (2-1/4 ^{2,5})
1/4 (1.0) ³	4	4	4
3/8 (1-1/8) ³	4	4	5
1/2 (1-1/2) ⁴	5	5	5
5/8 (1-5/8) ⁴	5	5	5
3/4 (1-3/4) ⁴	5	5	5

¹OD pipe diameter in inches; Values in parenthesis () indicate OD of pipe with insulation jacket.

²Diameter of pipe with insulation. Thickness of pipe insulation is typical. Actual required thickness may vary based on surrounding ambient conditions and should be calculated and specified by the design engineer.

³Insulation thickness (value in parenthesis) = 3/8 inch.

⁴Insulation thickness (value in parenthesis) = 1 inch.

⁵Insulation thickness (value in parenthesis) = 3/4 inch.

Multi F Outdoor Unit to Indoor Unit Piping Connections

Note:

Avoid Pipe Damage

- When routing field-provided piping, avoid damaging the outdoor unit from excessive vibration.
- Correctly route the piping so it does not make contact with mounting bolts. Allow room for field installation.
- Properly insulate the liquid and gas lines separately up to the point of connection at the unit frame.
- See table below for Multi F outdoor unit connection types.

Table 119: Outdoor Unit Piping Connections.

Outdoor Unit Piping Connections	LMU18CHV	LMU24CHV	LMU36CHV
Liquid Line Connection (in., OD) x Qty.	1/4 x 2	1/4 x 3	1/4 x 4
Vapor Line Connection (in., OD) x Qty.	3/8 x 2	3/8 x 3	3/8 x 4

Table 120: Indoor Unit Pipe Sizes.

Indoor Unit Capacity	Vapor Line Connection (in., OD)	Liquid Line Connection (in., OD)
7,000 Btu/h	Ø3/8	Ø1/4
9,000 Btu/h		
12,000 Btu/h		
15,000 Btu/h		
18,000 Btu/h	Ø1/2	
24,000 Btu/h		

Table 122: Indoor Unit Piping Connections.

Indoor Unit Capacity	Vapor Line Connection (in., OD)	Liquid Line Connection (in., OD)
7,000 Btu/h	Ø3/8	Ø1/4
9,000 Btu/h		
12,000 Btu/h		
15,000 Btu/h		
18,000 Btu/h	Ø5/8	Ø3/8
24,000 Btu/h	Ø1/2	Ø1/4

Connection sockets (included as a factory-supplied accessory with the indoor units) may need to be used when piping the indoor units to the outdoor unit.

Table 121: Connection Socket Dimensions.

Indoor Unit Capacity	Vapor (in., OD)		Liquid (in., OD)	
	A	B	A	B
18,000 Btu/h	Ø3/8 → Ø1/2, Ø1/2 → Ø5/8		Ø1/4 → Ø3/8	
24,000 Btu/h	Ø3/8 → Ø1/2		N/A	

Using the Connection Socket

1. Align the center of the piping sections and tighten the flare nut by hand.
2. Tighten the flare nut with a torque wrench, using the arrows on the wrench as a guide, until a click is heard.

Figure 281: Multi F Refrigerant Pipe Connections (LMU36CHV shown as example).

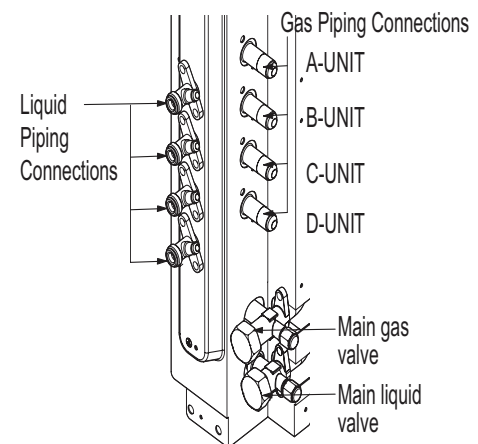


Figure 282: Connection Socket Diagram.

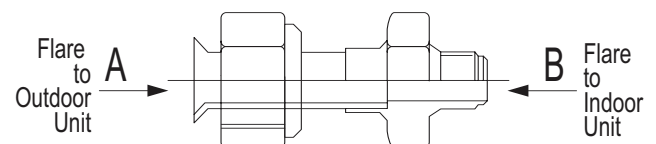
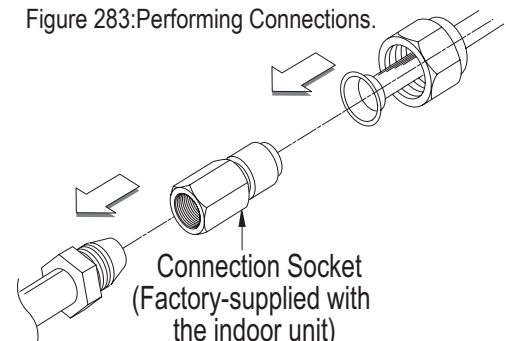


Figure 283: Performing Connections.



Multi F MAX Outdoor Unit System Piping Connections

Note:

Avoid Pipe Damage

- When routing field-provided piping, avoid damaging the outdoor unit from excessive vibration.
- Correctly route the piping so it does not make contact with mounting bolts. Allow room for field installation.
- Properly insulate the liquid and gas lines separately up to the point of connection at the unit frame.
- See table below for Multi F MAX outdoor unit connection types.

Table 123: Outdoor Unit Piping Connections.

Outdoor Unit Piping Connections	LMU540HV
Liquid Line Connection (in., OD) x Qty.	3/8 x 1
Vapor Line Connection (in., OD) x Qty.	3/4 x 1

Branch Distribution to Indoor Unit Piping Connections

- Install indoor unit liquid and vapor refrigerant pipes (and connection wiring) to the appropriate branch distribution ports.
- Clearly note on the indoor unit's refrigerant piping (liquid, vapor) which branch distribution port it is connected to (A, B, C, D).

Table 124: Branch Distribution Unit Piping Connections.

Branch Distribution Unit	PMBD3620	PMBD3630	PMBD3640	PMBD3641
<i>Piping Connections to Outdoor Unit</i>				
Liquid (in., OD) x Qty.	Ø3/8 x 1			
Vapor (in., OD) x Qty.	Ø3/4 x 1			
<i>Piping Connections to Indoor Units</i>				
Liquid (in., OD) x Qty.	Ø1/4 x 2	Ø1/4 x 3	Ø1/4 x 4	Ø1/4 x 3, Ø3/8 x 1
Vapor (in., OD) x Qty.	Ø3/8 x 2	Ø3/8 x 3	Ø3/8 x 4	Ø3/8 x 3, Ø5/8 x 1

Figure 284: Branch Distribution Ports to Indoor Units.

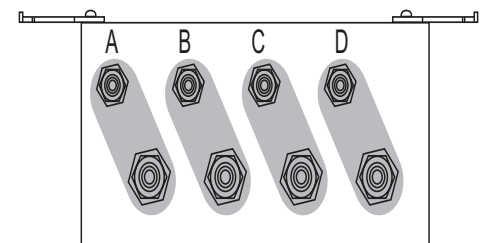


Table 125: Indoor Unit Pipe Sizes.

Indoor Unit Capacity	Vapor Line Connection (in., OD)	Liquid Line Connection (in., OD)
7,000 Btu/h	Ø3/8	Ø1/4
9,000 Btu/h		
12,000 Btu/h		
15,000 Btu/h		
18,000 Btu/h	Ø1/2	Ø3/8
24,000 Btu/h		
36,000 Btu/h	Ø5/8	Ø3/8

Table 127: Indoor Unit Piping Connections.

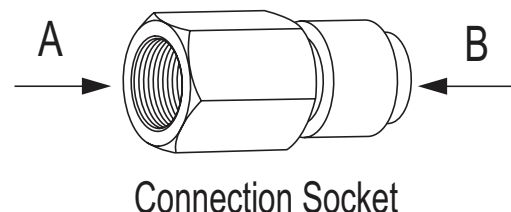
Indoor Unit Capacity	Vapor Line Connection (in., OD)	Liquid Line Connection (in., OD)
7,000 Btu/h	Ø3/8	Ø1/4
9,000 Btu/h		
12,000 Btu/h		
15,000 Btu/h		
18,000 Btu/h	Ø5/8	Ø3/8
24,000 Btu/h	Ø1/2	Ø1/4
36,000 Btu/h	Ø5/8	Ø3/8

Connection sockets (included as a factory-supplied accessory with the indoor units) may need to be used when piping the indoor units to the branch distribution unit.

Table 126: Connection Socket Dimensions.

Indoor Unit Capacity	Vapor (in., OD)		Liquid (in., OD)	
	A	B	A	B
18,000 Btu/h	Ø3/8 → Ø1/2, Ø1/2 → Ø5/8		Ø1/4 → Ø3/8	
24,000 Btu/h	Ø3/8 → Ø1/2		N/A	
36,000 Btu/h	Ø1/2 → Ø5/8		Ø1/4 → Ø3/8	

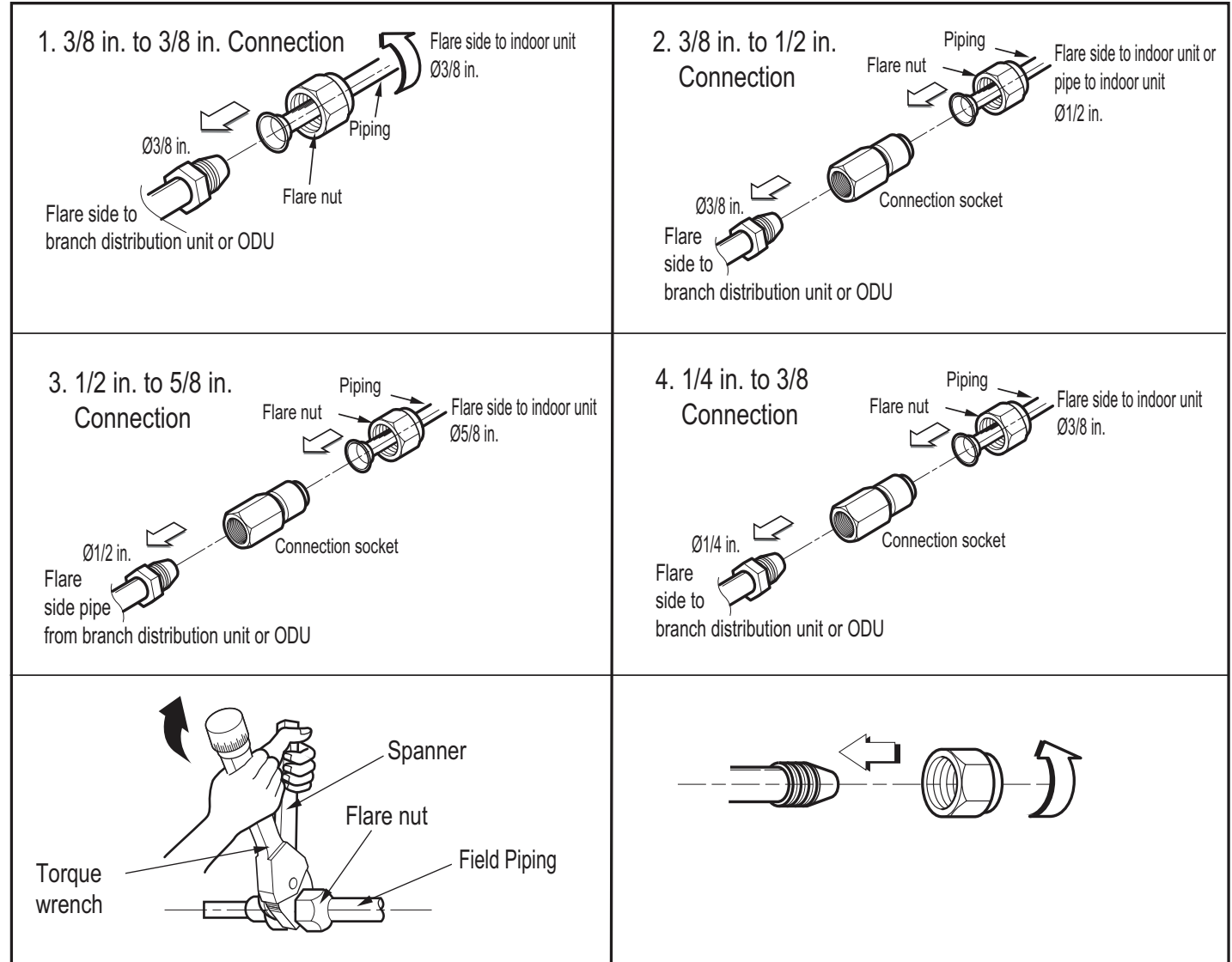
Figure 285: Connection Socket Diagram.



Multi F System Piping Connections

1. Align the center of the piping sections and tighten the flare nut by hand.
2. Tighten the flare nut with a torque wrench, using the arrows on the wrench as a guide, until a click is heard.
3. Wrap insulation around the connection.

Figure 286: Possible Outdoor Unit or Branch Distribution Unit to Indoor Unit Connections.



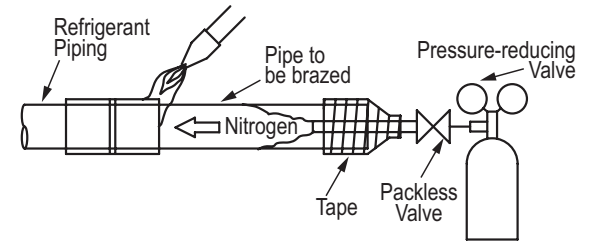
Brazing Practices

Note:

Keep the piping system free of contaminants and debris such as copper burrs, slag, or carbon dust during installation.

1. All joints are brazed in the field. Multi F refrigeration system components contain very small capillary tubes, small orifices, electronic expansion valves, oil separators, and heat exchangers that can easily become blocked.
 - Store pipe stock in a dry place; keep stored pipe capped and clean.
 - Blow clean all pipe sections with dry nitrogen before assembly.
2. Proper system operation depends on the installer using best practices and utmost care while assembling the piping system.
 - Use adapters to assemble different sizes of pipe.
 - Do not use flux, soft solder, or anti-oxidant agents.
 - Use a tubing cutter; do not use a saw to cut pipe. De-burr and clean all cuts before assembly.

Figure 287: Refrigerant Pipe Brazing.



3. Brazing Joints:

- Use a dry nitrogen purge operating at a minimum pressure of three (3) psig and maintain a steady flow.
- Use a 15% silver phosphorous copper brazing alloy to avoid overheating and produce good flow.
- Protect isolation valves, electronic expansion valves, and other heat-sensitive control components from excessive heat with a wet rag or a heat barrier spray product

Flare Connection Practices

Note:

Improperly installed flare connections can lead to refrigerant leaks.

1. Place a couple of drops of refrigerant oil on the opening rim of the flare before assembling. Take care not to add any contaminants.
2. Align the center of the refrigerant pipe and corresponding connection and tighten the flare nut by hand.
3. Following the guidelines as outlined in Table 125 for the amount of torque to use, tighten the flare nut with a torque wrench until the wrench clicks.
4. When flare is sufficiently tightened and the system has been tested for refrigerant leaks, wrap insulation around the connection.

Figure 288: Flare Connection, Isometric View.

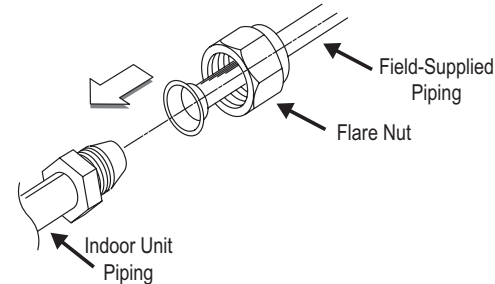
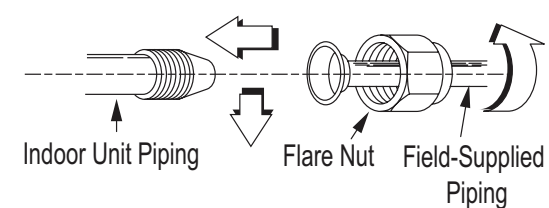


Figure 289: Flare Connection, Side View.



Note:

When tightening the flare unit with a torque wrench, ensure the direction for tightening follows the arrow on the wrench.

Figure 290: Using the Torque Wrench.

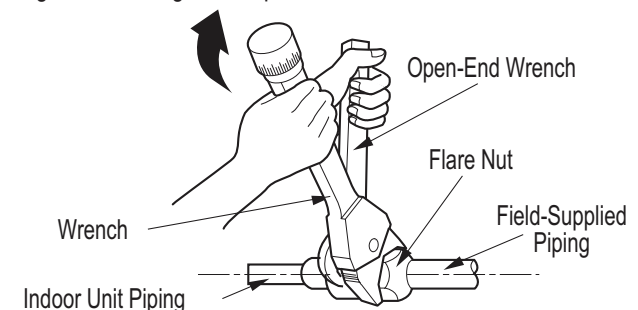


Table 128: Torque Wrench Tightening.

Piping O.D. (in.)	Torque (lbs. / ft.)
1/4	13-18
3/8	24.6-30.4
1/2	39.8-47.7
5/8	45.6-59.3
3/4	71.6-87.5

Refrigerant Piping System Insulation

All refrigerant piping including Y-branch connections, field-provided isolation ball valves, service valves, and elbows shall be completely insulated using closed cell pipe insulation.

To prevent heat loss/heat gain through the refrigerant piping, all refrigerant piping including liquid lines and vapor lines shall be insulated separately. Insulation shall be a minimum 1/2" thick, and thickness may need to be increased based on ambient conditions and local codes. All insulation joints shall be glued with no air gaps. Insulation material shall fit snugly against the refrigeration pipe with no air space between it and the pipe. Insulation passing through pipe hangers, inside conduit, and/or sleeves must not be compressed. Protect insulation inside hangers and supports with a second layer. All pipe insulation exposed to the sun and outdoor elements shall be properly protected with PVC, aluminum vapor barrier, or alternatively placed in a weather-resistant enclosure such as a pipe rack with a top cover; and meet local codes. Pay special attention to insulating the pipes installed in the ceiling plenum.

LG-provided Y-branches are shipped from the factory with pre-formed peel-and-stick foam insulation jackets, with a 1.84 lb./ft.³ density, 1/2" thickness, and meet UL94 MF-1 flammability.

The design engineer should perform calculations to determine if the factory-supplied insulation jackets are sufficient to meet local codes and avoid sweating. Maximum refrigerant piping temperature is +227°F; minimum refrigerant piping temperature is -4°F. Add additional insulation if necessary. Check the fit of the insulation jacket after the header fitting and all run-out pipes are installed. Mark all pipes at the point where the insulation jacket ends. Remove the jacket. Install field provided insulation on the run-out and main trunk pipes first. Install the LG-provided insulation plugs on the ends of all unused header ports. Peel the adhesive glue protector slip from the insulation jacket and install the clam-shell jacket over the fitting.

Minimum Refrigerant Pipe Ethylene Propylene Diene Methylene (EPDM) Insulation Wall Thickness Requirements

Note:

Follow local codes when selecting EPDM insulation wall thickness.

Table 129: Insulation Guidelines for Typical and Special Circumstances.

Classification		Air-conditioned location		Non-air conditioned location	
		1. Typical location	2. Special location	3. Typical location	4. Special location
Liquid pipe	ø1/4 inches	1/2 inches	1/2 inches	1/2 inches	1/2 inches
	ø3/8 inches				
	≥ø1/2 inches				
Vapor pipe	ø3/8 inches	1/2 inches	3/4 inches	3/4 inches	1 inch
	ø1/2 inches				
	ø5/8 inches				
	ø3/4 inches				

1. Air-conditioned, Typical location: When the piping passes through an indoor area where the indoor unit operates.

- Apartment, classroom, office, mall, hospital, etc.

2. Air-conditioned, Special location

1. When the location is air conditioned, but there is severe temperature/humidity difference due to high ceilings
 - Church, auditorium, theater, lobby, etc.
2. When the location is air conditioned, but internal temperature/humidity are high
 - Bathroom, swimming pool, locker room, etc.

3. Non-air conditioned, Typical location: When the piping passes through an indoor area where the indoor unit does not operate.

- Hallway or a dormitory or school, etc.

4. Non-air conditioned, Special location: If conditions 1 and 2 below are present.

1. When the piping passes through an indoor area where the indoor unit does not operate.
2. When the humidity is high and there is no air flow in the location where the piping is installed.
 - The thickness of the above insulation material is based on heat conductivity of 0.61 Btu/in/h/ft²/°F.

Condensate Drain Piping

Outdoor Units

Outdoor unit requires condensate drain piping. Condensate drain pipe is constructed with materials approved by local code. See “Placement Considerations” on page 185 to page 190 for information on outdoor unit placement and condensate drainage.

Indoor Units

All indoor units generate water during cooling operation, therefore, how to properly handle this condensation must be considered. Some indoor units include factory-installed drain pumps; others apply the gravity drain method.

Depending on the location of the indoor unit, condensation can be drained directly to the outside of the building, or a common indoor unit drainage piping system can be installed, both incorporating PVC piping.

Table 130: Indoor Unit Drain Piping Specifications.

Indoor Unit	Drain Type	Drain Pipe Diameter (OD / ID, in.)	Drain Amount (gal. / min. at 0.033 ft. height)
Art Cool Wall-Mounted	Gravity	13/16 / 5/8	—
Art Cool Gallery	Gravity	13/16 / 5/8	—
Standard Wall-Mounted	Gravity	13/16 / 5/8	—
Ceiling-Concealed Ducted (Low Static and High Static)	27-1/2 in. Lift Drain Pump, Factory Installed	Ø1-1/4 / Ø1	0.105
Four-Way Ceiling Cassette	27-1/2 in. Lift Drain Pump, Factory Installed	Ø1-1/4 / Ø1	0.105
Vertical-Horizontal Air Handling Unit	Gravity	Ø3/4 / —	—

Figure 291: Diagram of an Indoor Unit with a Gravity Drain.

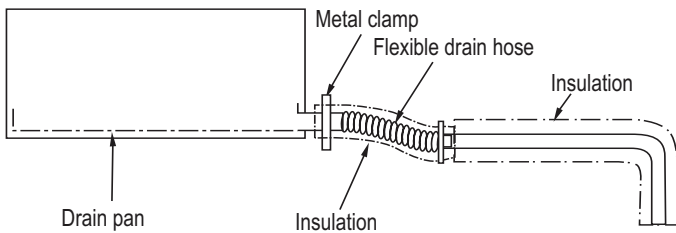
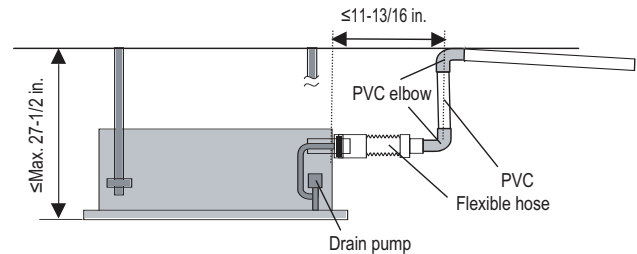


Figure 292: Diagram of an Indoor Unit with a Drain Pump.



Note:

Ensure the indoor unit, refrigerant piping, power wiring / communication cables, and drain piping is properly supported with anchor bolts and clamp hangers positioned at 3.3 to 4.9 foot intervals.

Flexible Drain Hose

Some indoor units include a factory-provided flexible drain pipe for installation.

- Install the flexible drain pipe as straight as possible; sharp angles may cause the pipe to deteriorate and may crack over time.
- Connect the flexible drain pipe with a round clamp. If the flexible drain pipe is not installed properly, water will leak from the connection.
- Do not include a reverse slope in the drain connection.

Figure 293: Flexible Drain Hose Connection.

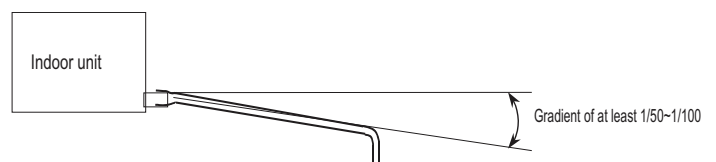


Clamp the Flexible Drain Hose Connection

Drainage Gradient

The gradient for drain piping should be at least 1/50 to 1/100. Ensure any holes through ceilings, walls, etc., are large enough to accommodate both the drain piping and any insulation.

Figure 294: Drain Piping Gradient Recommendation.

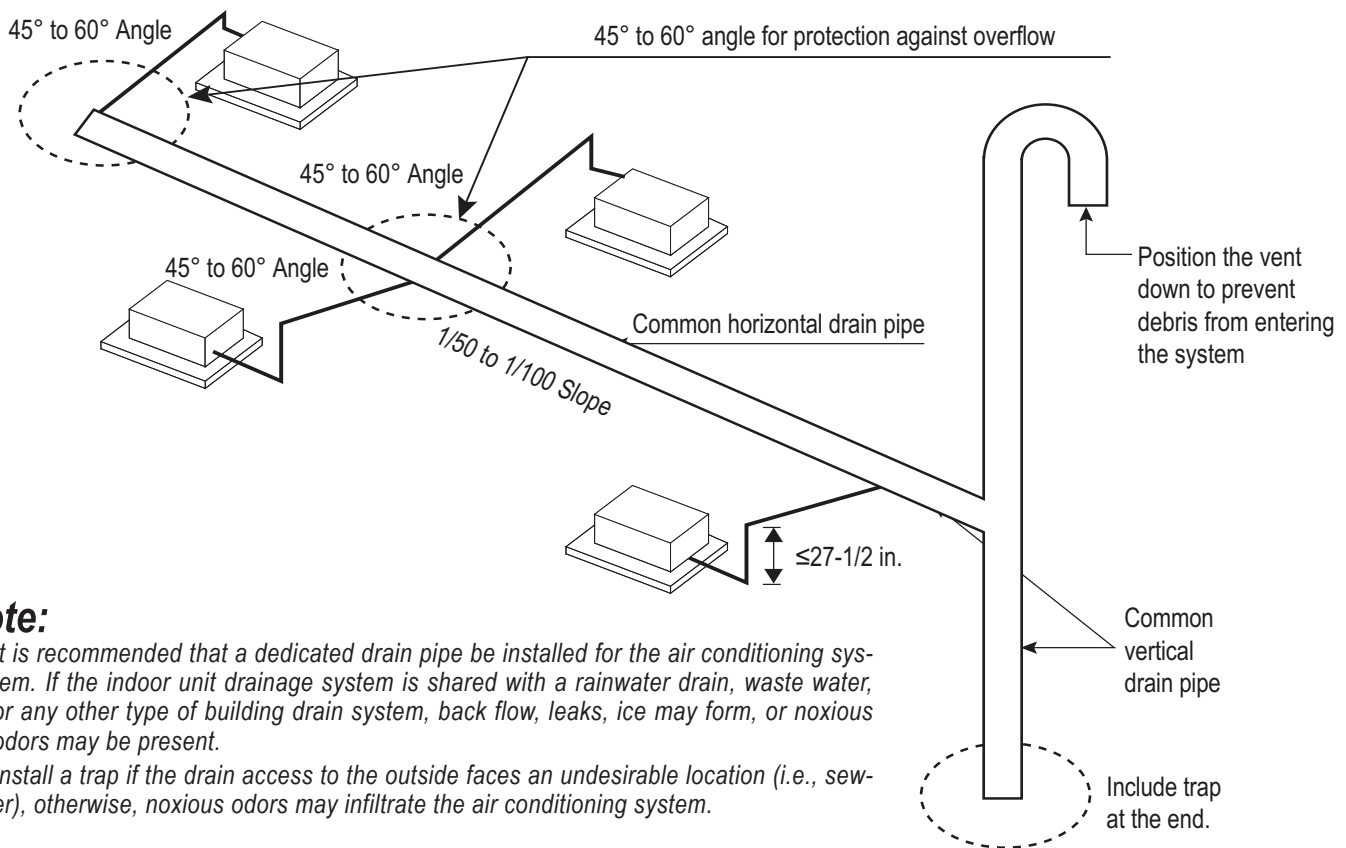


Condensate Drain Piping

Common Indoor Unit Drainage System

It is usual work practice to connect individual indoor unit drain pipes to one common indoor unit drainage system. The diameter of the common vertical drain pipe should be as large as necessary. (For systems with <80,000 Btu/h total capacity of all connected indoor units, the standard size for the common vertical drain pipe is 0.98 ID, in. and 1.26 OD, in.) The diameter of the horizontal pipe should be the same or larger than the vertical drain pipe. To avoid property damage in the event of the primary drain becoming clogged, and to optimize drain system performance, it may be prudent to install a secondary drain line. Design the drain system to plan for winter operation (condensate line may freeze up if condensate does not properly drain away). Drain all generated condensate from the external condensate pan to an appropriate area. Install a trap in the condensate lines as near to the indoor unit coil as possible; to prevent overflow the outlet of each trap should be positioned below its connection to the condensate pan. All traps should be primed, insulated, and leak tested if located above an inhabited space.

Figure 295: Example of a Common Indoor Unit Drainage System.



Note:

- It is recommended that a dedicated drain pipe be installed for the air conditioning system. If the indoor unit drainage system is shared with a rainwater drain, waste water, or any other type of building drain system, back flow, leaks, ice may form, or noxious odors may be present.
- Install a trap if the drain access to the outside faces an undesirable location (i.e., sewer), otherwise, noxious odors may infiltrate the air conditioning system.

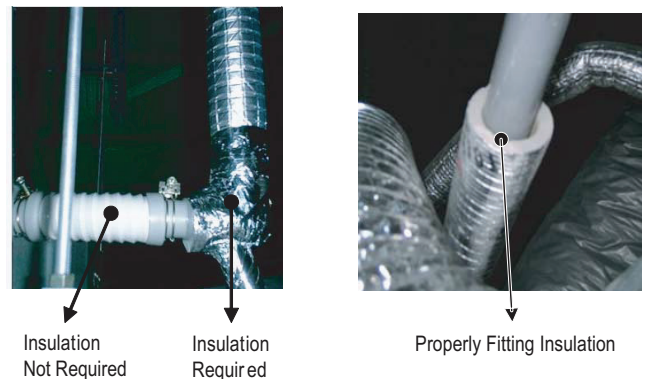
Drain Leak Test

A leak test should be performed 24 hours after the drainage system has been installed. Only use water for the test; other liquids are unacceptable.

Drain Pipe Insulation

To prevent condensate from forming on the drain piping, install field-supplied 0.4 inch thick polyethylene. The insulation should be securely fastened with all connected joints and ends properly covered.

Figure 296: Properly Insulating the Drainage Piping.



- LG Y-Branch Kit PMBL5620 is required when installing two branch distribution units in parallel on one LG Multi F MAX system.
- The kit must be properly installed following instructions in the applicable LG manual. Field-supplied branch fittings are not permitted.
- Kit components must be kept free of debris and be dry before installation.
- All Y-Branch Kits include a clam shell, peel-and-stick insulation jacket.

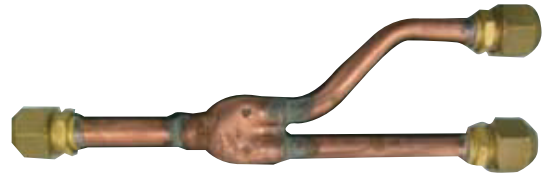


Table 131:Fitting Properties.

Material	Copper
Design Pressure	551 psig

Table 132: Multi F MAX Y-Branch Connection Diameters.

Model	Y-Branch Type	Port Identifier (inch)		
		1	2	3
PMBL5620	Liquid	Ø3/8	Ø3/8	Ø3/8
	Vapor	Ø3/4	Ø3/4	Ø3/4
	Y-Branch Type	Dimensions (inch)		
		X	Y	
	Liquid	13.80	3.24	
	Vapor	12.48	3.02	

Figure 297:Y-Branch Port Identifier Diagram.

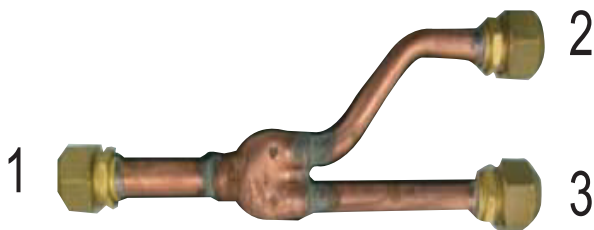


Figure 298:Y-Branch Dimensions Diagram.

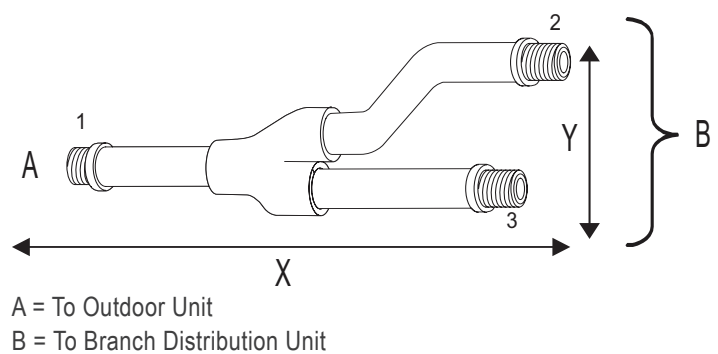
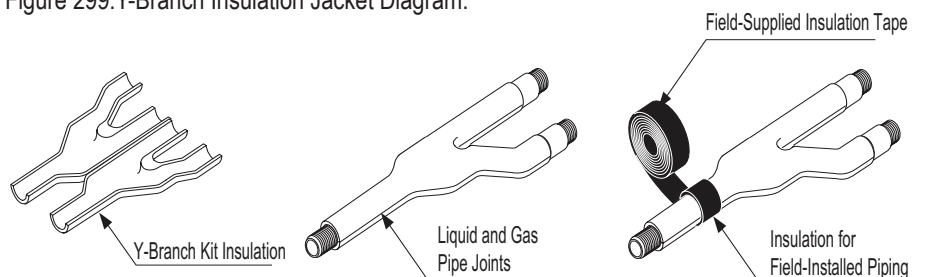


Table 133: Insulation Jacket Properties.

Material	Polyolefin Foam
UL94 Flame Classification	HF-1
Density	1.84 lbs./ft. ³
Thermal Conductivity	.0208 Btu/h/ft. °R
Thickness	1/2 inch

Figure 299:Y-Branch Insulation Jacket Diagram.



WIRING CONNECTIONS

“General Information” on page 214

**“Power Wiring (208-230V) and Communications Cable
Details” on page 217**

“Indoor Unit Group Control” on page 222

⚠ WARNING

- Only qualified technicians—in accordance with federal, state, and local codes, and manufacturer product diagrams and requirements—should install the power wiring and communication cables.
- Use only copper wiring that is stranded, shielded with the wires separately insulated.
- Do not use a multi-conductor cable with more than five (5) wires in one (1) core.
- Power wiring and communications cable sizes must comply with applicable federal UL / ETL, state, and local codes.
- Verify that the branch switch and circuit breaker are set to OFF before installing the wiring system.
- Do not operate the air conditioning system until the refrigerant piping installation is complete. Operating the system before refrigerant piping is finalized may damage the compressor.
- Install a ground wire for the outdoor units, indoor units, and branch distribution units.
- Install a main shutoff switch or circuit breaker that interrupts all power sources simultaneously (circuit breaker should be resistant to electromagnetic currents).
- To avoid the possibility of explosion, fire, etc., do not connect the ground wiring to gas or sewage pipes, lightning rods, and telephone wires. Use clamps to prevent the wires from touching the piping.
- Use ring terminals to attach the wiring. Verify that all power wiring and communications cable terminals are securely attached; ensure enough slack is included in the wiring and cables to avoid damaging the connections.
- Use a conduit to protect the power wiring.
- Do not install a phase-advancing capacitor; the outdoor unit may overheat.

Power Wiring and Communications Cable Installation

For both Multi F and Multi F MAX systems, power is wired to the outdoor unit only. The outdoor unit will supply power to the branch distribution units (Multi F MAX systems only) and the indoor units through the power wiring / communications cable.

Electrical Specifications

1. Multi F and Multi F MAX Outdoor Units: 1Ø, 208-230V, 60Hz
2. Indoor units / Branch Distribution Units (Multi F MAX systems only): 1Ø, 208-230V, 60Hz from the outdoor unit (Indoor units draw minimal power.)
3. Power supply wire type and size should be selected based on NEC and local codes. Maximum allowable voltage fluctuation $\pm 10\%$ of the nameplate rated value.
4. Properly ground the outdoor unit per NEC and / or local code.
5. Use only copper wiring that is stranded and shielded with the wires separately insulated.

Power Wiring / Communications Cable Specifications

- From Multi F Outdoor Units to Indoor Units = 4 x 18AWG
- From Multi F MAX Outdoor Units to Branch Distribution Units = 4 x 16AWG
- From Multi F MAX Branch Distribution Units to Indoor Units = 4 x 18AWG
- Maximum Allowable Temperature for Wiring: 194°F
- Multi F System Maximum Cable Length: 82 ft.
- Multi F MAX System Maximum Cable Length:
 - Outdoor Unit to Branch Distribution Unit(s): 180.4 ft.
 - Branch Distribution Unit(s) to Indoor Unit(s): 49.2 ft.
- Indoor Unit(s) to Wired Controller: Three-core cable

Figure 300: Power Wiring to Multi F and Multi F MAX ODU.

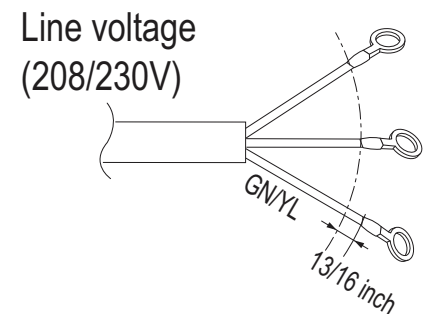
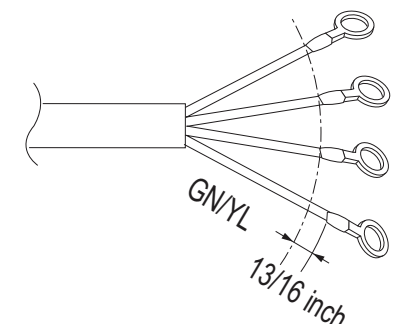


Figure 301: Power Wiring and Communications Cable from the Multi F ODU to the IDUs, or from the Multi F MAX ODU to the BDUs and from the BD Unit to the IDUs.



Connecting the Power Wiring / Communications Cable

Best practice dictates using ring or spade terminals to terminate power wiring at the power terminal block. If ring terminals or spade clips are not available, then:

- Do not terminate different gauge wires to the power terminal block. (Slack in the wiring may generate heat.)
- When terminating wires of the same thickness, follow the instructions demonstrated in the figures below.
- Firmly attach the wire; secure in a way to prevent external forces from being imparted on the terminal block.
- Use an appropriately sized screwdriver for tightening the terminals.
- Do not overtighten the connections; overtightening may damage the terminals.

Figure 302: Close up of a Typical Ring Terminal.

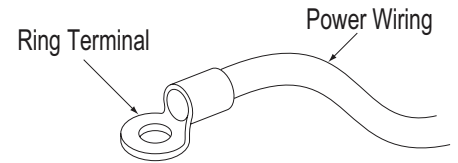


Figure 303: Close up of the Indoor Unit Terminal Block.

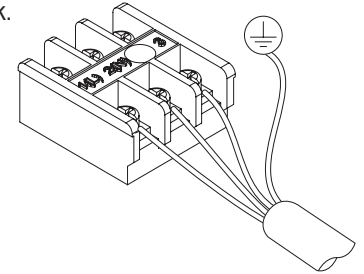
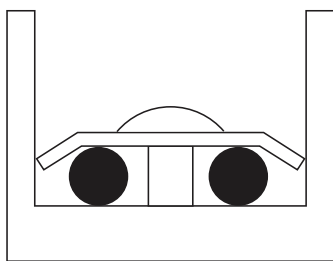
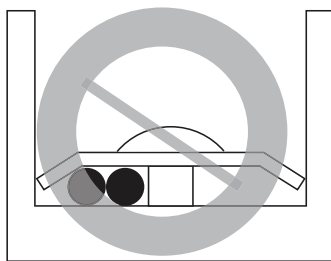


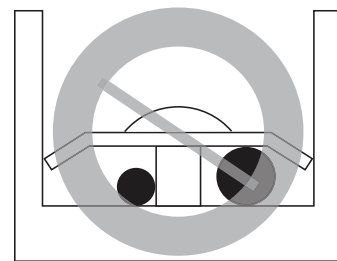
Figure 304: Proper and Improper Power Wiring Connections.



Terminate multiple power wires of the same gauge to both sides.



Do not terminate two wires on one side.



Do not terminate different gauge wires to a terminal block.

● :Copper Wire

WARNING

- There is a risk of fire, electric shock, physical harm or injury, or death if the power wires are not properly terminated and / or firmly attached.
- Never apply line voltage power to the communications cable terminal block. If contact is made, the PCBs may be damaged.

Note:

Always include some allowance in the wiring length when terminating. Provide some slack to facilitate removing the electrical panels while servicing.

WIRING CONNECTIONS

General Information

MULTI F
MULTI F MAX

Figure 305: Multi F System General Power / Communications System Schematic.

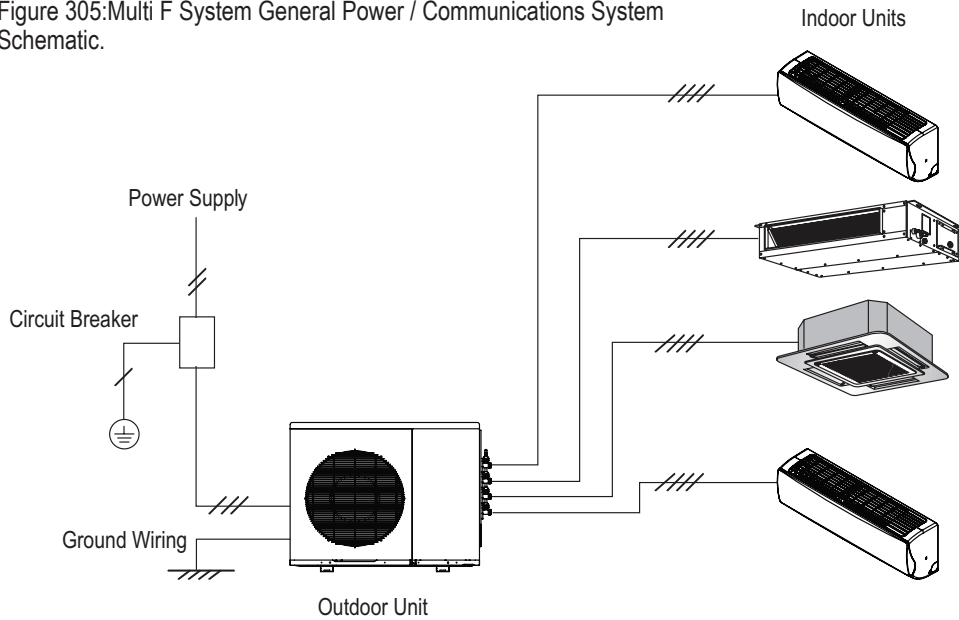
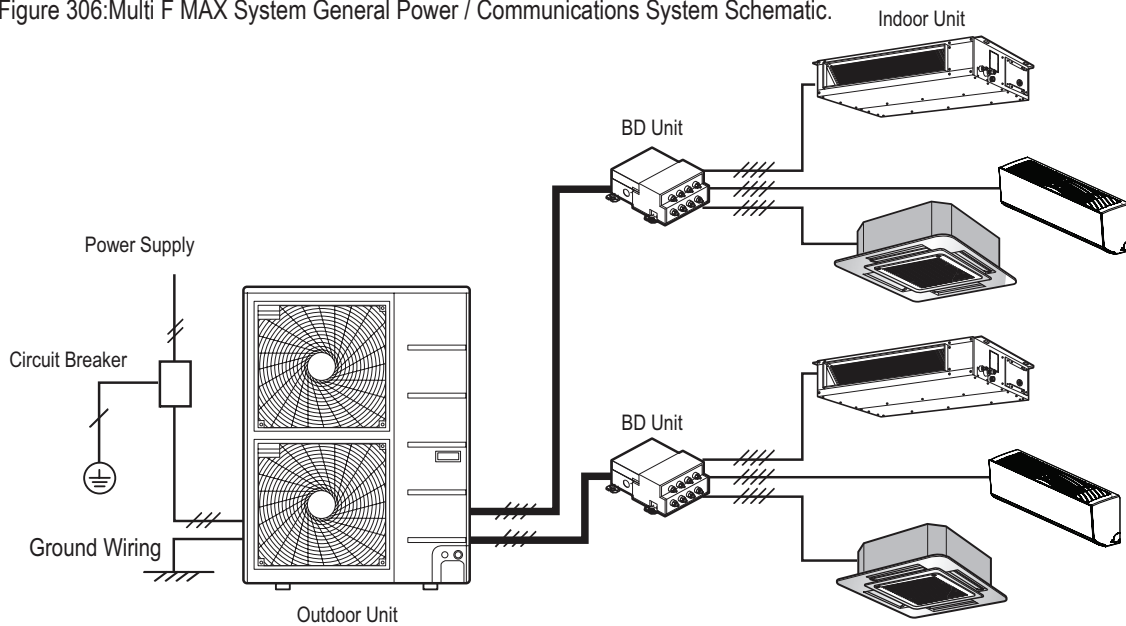


Figure 306: Multi F MAX System General Power / Communications System Schematic.



Note:

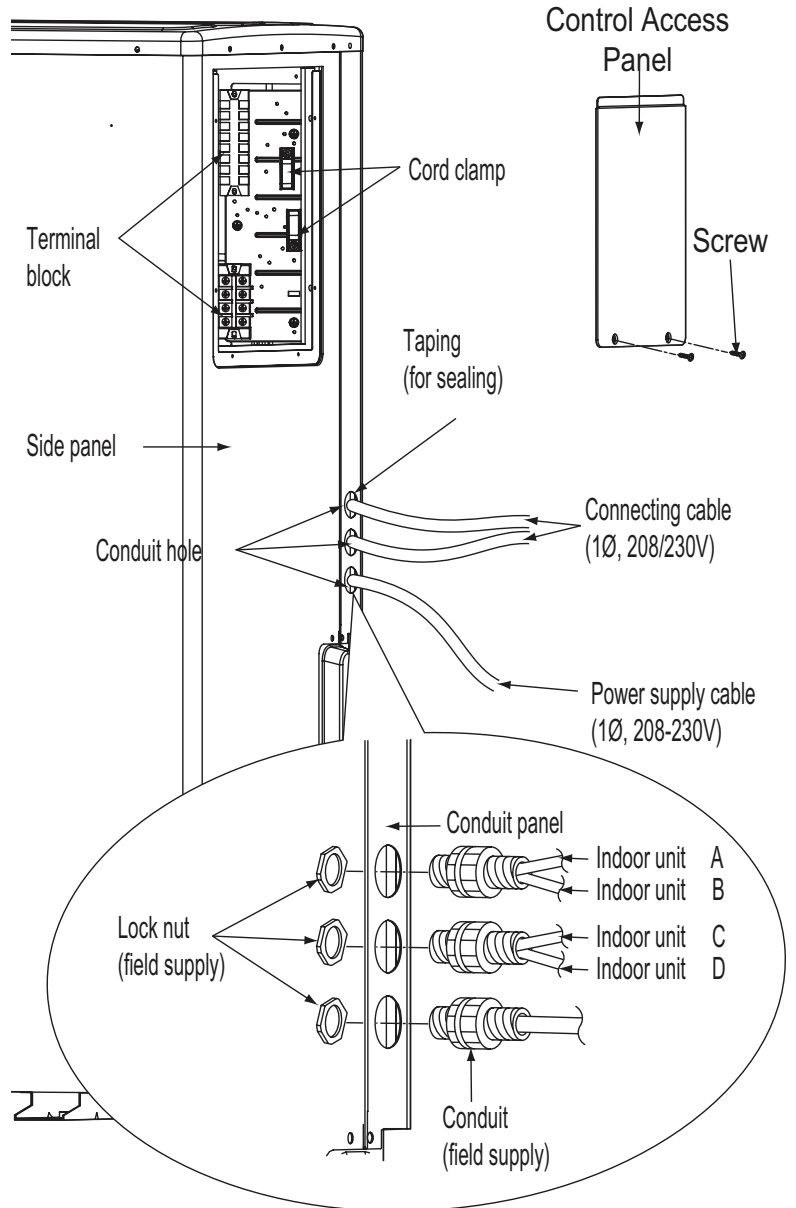
- Secure the separate wires in the control box panel using zip ties.
- Secure wiring with accessory clamps so that it does not touch piping.
- Use a conduit for the cable
- Outside the unit, make sure the communications cable and the power wiring are separately shielded, otherwise, the outdoor unit operation may be affected by electrical noise and will malfunction or fail.

- Find the outdoor unit terminal block by unscrewing the control access panel.
- Side panel of the outdoor unit has knockout holes for the conduits. After install is complete, seal up any gaps between the panel and the conduits.
- Clamp is included near the terminal block to help protect the connections from strain on the cables.

WARNING

- Always have a trained technician properly ground the outdoor unit. If the outdoor unit is not properly grounded, there is a risk of electric shock.
- Use a conduit for the power wiring.
- The communications cable should be separated and isolated from the outdoor unit power wiring, computers, radio and television broadcasting facilities, as well as medical imaging equipment.

Figure 307: Example of Power Wiring and Communications Cable Terminations.

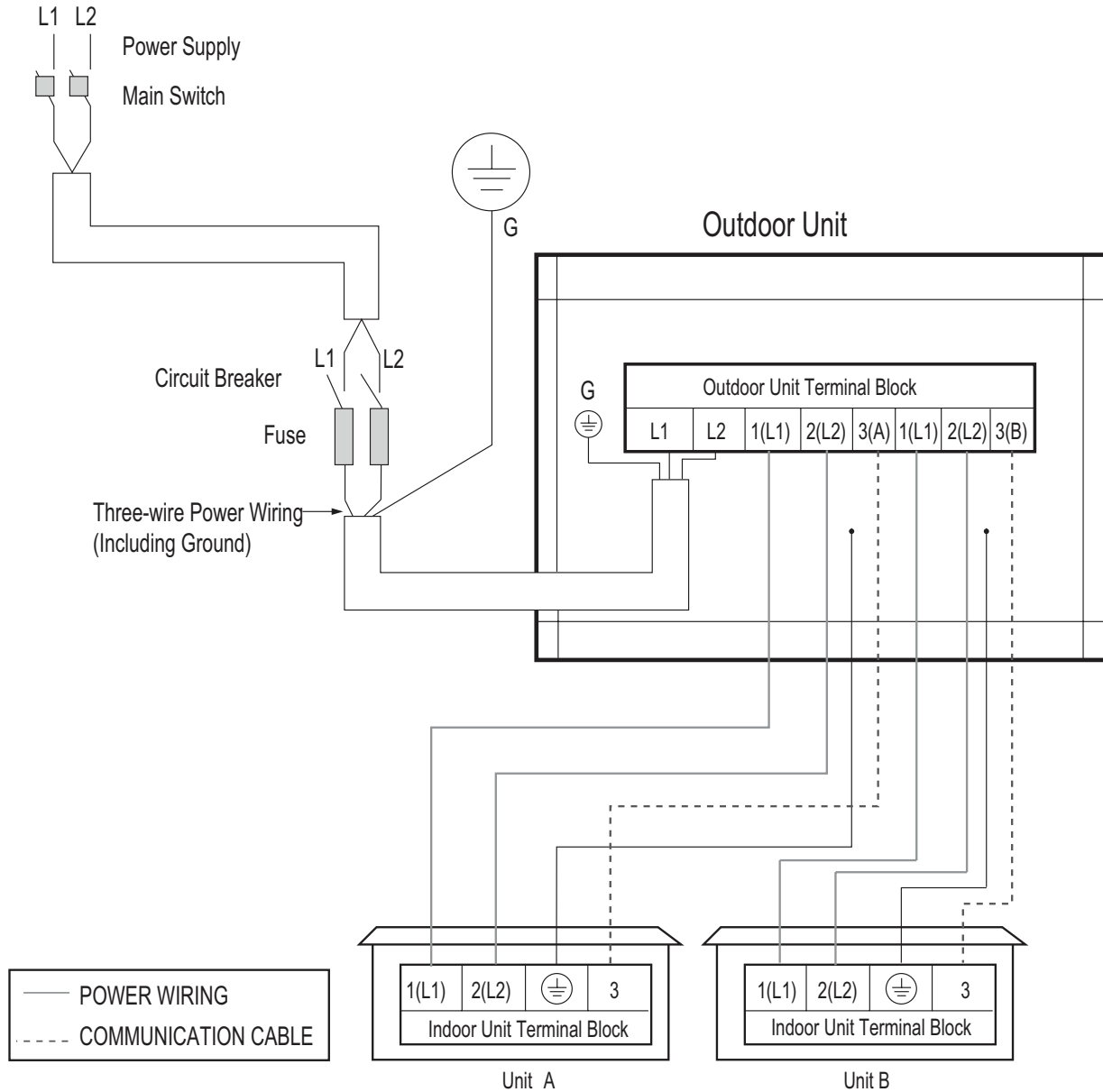


WIRING CONNECTIONS

Power Wiring (208-230V) and Communications Cable Details

MULTI F
MULTI F MAX

Figure 308: Multi F LMU18CHV System Power Wiring and Communications Cable.

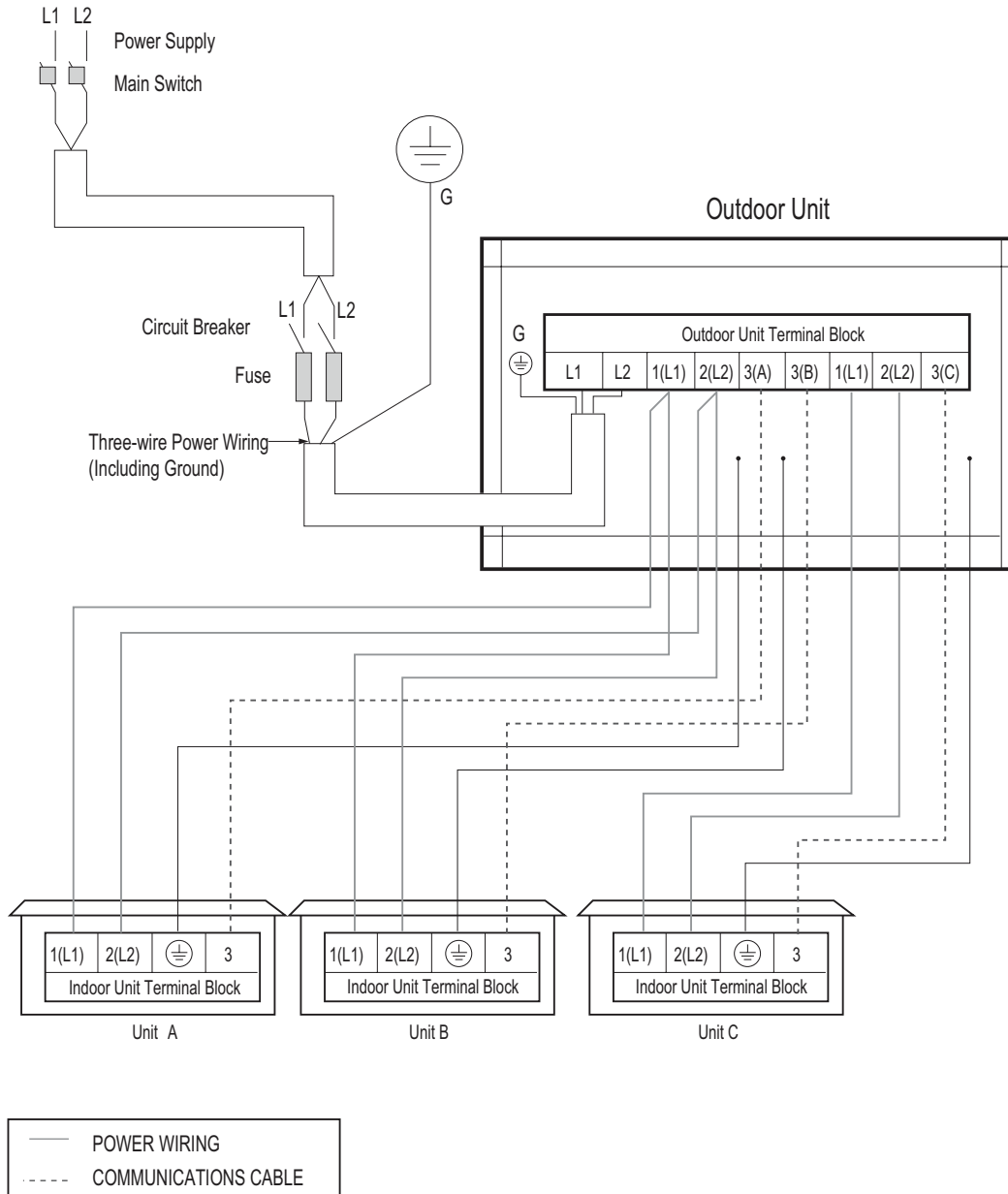


Multi F and Multi F MAX Indoor Unit Engineering Manual

⚠ WARNING

- All field-supplied wiring, components, and materials should follow national, state, and local codes and requirements.
- Use only stranded, shielded copper conductor.
- Ground wiring is required to prevent accidental electrical shock during current leakage, communication problems from electrical noise, and motor current leakage. Do not connect the ground line to the pipes.
- Install a main shutoff switch or circuit breaker that interrupts all power sources simultaneously.
- Wiring cable size must comply with applicable national, state, and local codes.

Figure 309: Multi F LMU24CHV System Power Wiring and Communications Cable.



WARNING

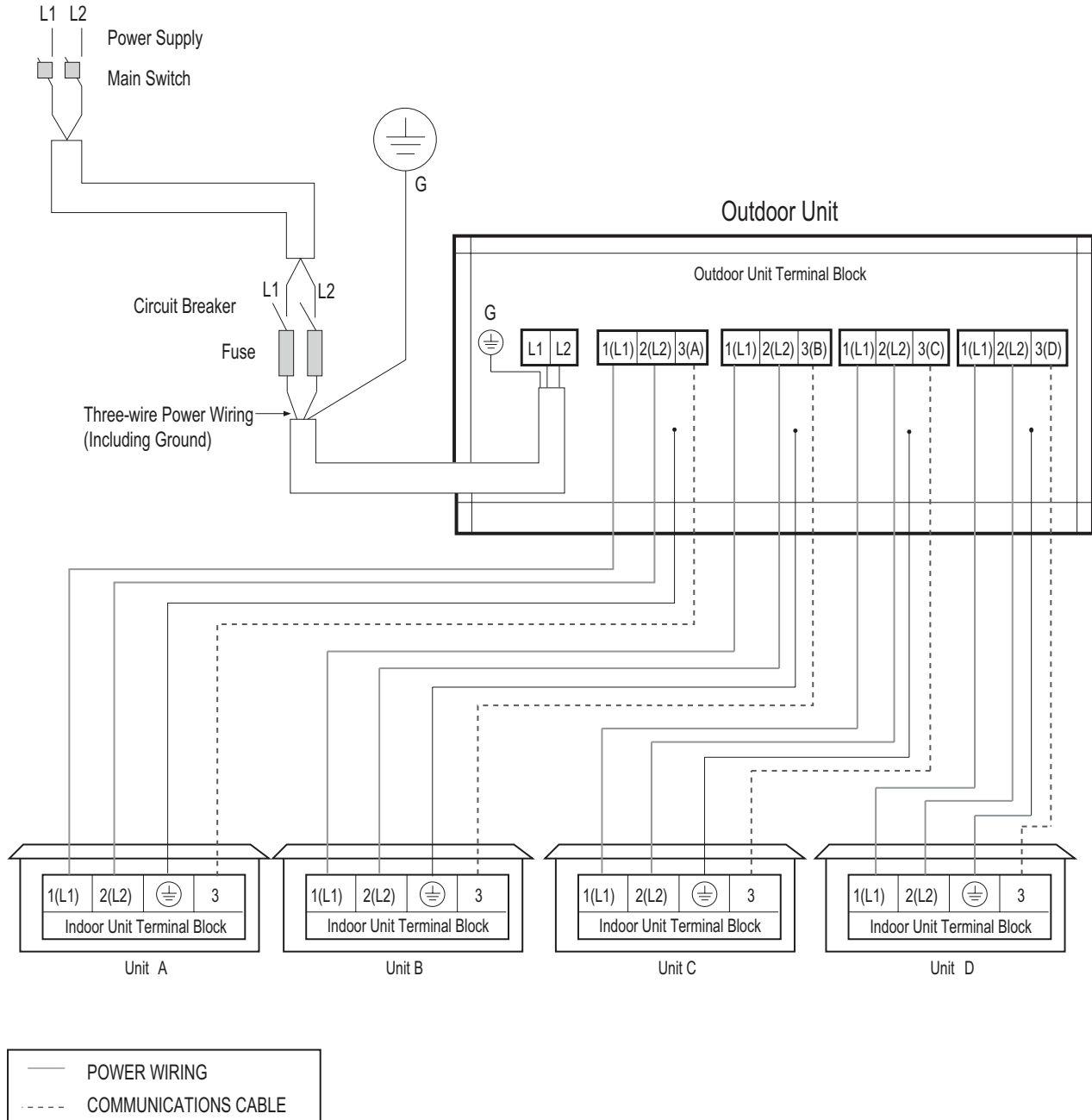
- All field-supplied wiring, components, and materials should follow national, state, and local codes and requirements.
- Use only stranded, shielded copper conductor.
- Ground wiring is required to prevent accidental electrical shock during current leakage, communication problems from electrical noise, and motor current leakage. Do not connect the ground line to the pipes.
- Install a main shutoff switch or circuit breaker that interrupts all power sources simultaneously.
- Wiring cable size must comply with applicable national, state, and local codes.

WIRING CONNECTIONS

Power Wiring (208-230V) and Communications Cable Details

MULTI F
MULTI F MAX

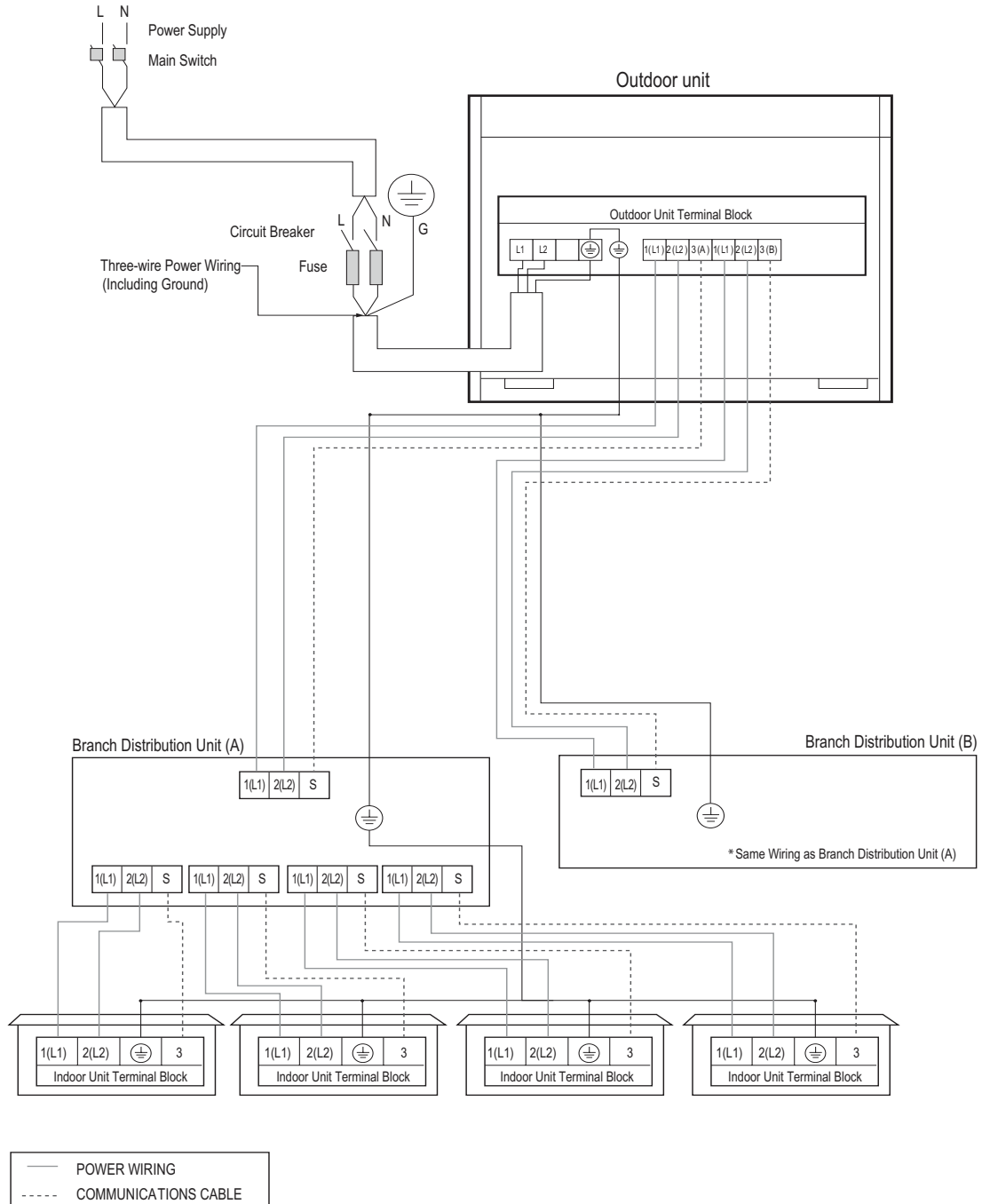
Figure 310: Multi F LMU36CHV System Power Wiring and Communications Cable.



⚠ WARNING

- All field-supplied wiring, components, and materials should follow national, state, and local codes and requirements.
- Use only stranded, shielded copper conductor.
- Ground wiring is required to prevent accidental electrical shock during current leakage, communication problems from electrical noise, and motor current leakage. Do not connect the ground line to the pipes.
- Install a main shutoff switch or circuit breaker that interrupts all power sources simultaneously.
- Wiring cable size must comply with applicable national, state, and local codes.

Figure 311: Multi F MAX LMU540HV System Power Wiring and Communications Cable.



⚠ WARNING

- All field-supplied wiring, components, and materials should follow national, state, and local codes and requirements.
- Use only stranded, shielded copper conductor.
- Ground wiring is required to prevent accidental electrical shock during current leakage, communication problems from electrical noise, and motor current leakage. Do not connect the ground line to the pipes.
- Install a main shutoff switch or circuit breaker that interrupts all power sources simultaneously.
- Wiring cable size must comply with applicable national, state, and local codes.

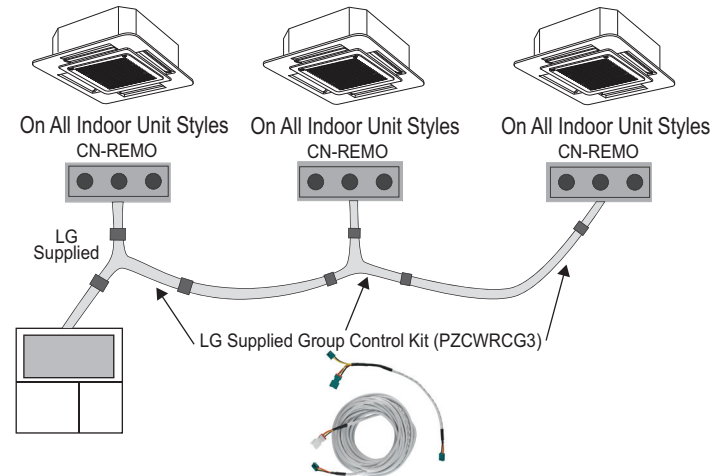
Communication Cables Between Multiple Indoor Units Operating as a Group (Group Control)

1. If any indoor units were specified to operate in unison, use one (or multiple) three-core Group Control Kit (sold separately) containing extension and Y-splitter cables. One (1) group control cable kit for each indoor unit in the group except for the last indoor unit.
2. Always use an LG provided group control communications cable (Group Control Kit; sold separately) between the indoor unit and the wall-mounted zone controller.
3. NEVER splice, cut, or extend cable length with field provided cable.
4. A maximum of 16 indoor units can be connected to a wired remote controller (maximum wire length: 164 feet). Before running cable, decide which indoor unit will be the "Master;" set the remaining as "Slave." The zone controller will be connected to the "Master."
5. Identify each indoor unit operating as a group as "Master" or "Slave". Adjust the pertinent DIP switch at each indoor unit. On wall mounted indoor unit models, set the assignment using the handheld remote controller.
6. Use a daisy chain configuration and connect all of the group's indoor units together starting at the "Master" unit.

General Specifications

- Wired remote controllers can be connected to all indoor unit types.
- Wireless handheld controllers can be used in conjunction with wired remote controllers.
- A dry contact unit can be connected with a central controller simultaneously.
 - The master indoor unit is recognized by the dry contact unit and the central controller.
 - Group Control only available for indoor units manufactured after February 2009.
 - The central controller can control indoor units after setting the address of the master indoor unit only.
 - Slave indoor unit cannot be individually controlled by central controller.
 - Slave indoor unit will operate like master indoor unit.
- If an error occurs with the indoor unit, the error will be displayed on the wired remote controller.
- The following functions are available with group control:
 - Selection of operation options (operation/mode/set temperature)
 - Control of air flow rate (High/Medium/Low)

Figure 312: Indoor Unit Group to Zone Controller Connections.



Note:

Cable connected to Zone Controller is the factory default connection.

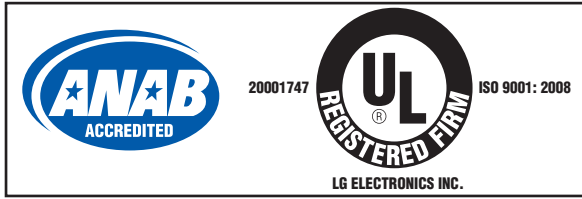
Table 134: Accessories Required for Group Control.

Accessory	Model Number	Image
Wired Remote Group Control Cable Assembly - Required for connecting multiple indoor units to a control group	PZCWRG3	
Wired Remote/Wired Remote Extension Cable - Required for extending the distance between indoor units or remote controllers in a control group	PZCWRC1	

Table 135: Table of Acronyms.

ABS	Acrylonitrile Butadiene Styrene	IAQ	Indoor Air Quality
AC	Air Conditioner	IDU	Indoor Unit
ACP	Advanced Control Platform	IUCF	Indoor Unit Correction Factor
ARI	Air Conditioning and Refrigeration Institute	KTL	Korea Testing Laboratories
ASHRAE	American Society of Heating, Refrigeration, and Air Conditioning	LATS	LG Air Conditioning Technical Solution
AWG	American Wire Gauge	LGAP	LG Air Conditioner Protocol
BDU	Branch Distribution (Unit)	MAT	Mixed Air Temperature
Btu/h	British Thermal Units per hour	MBh	Thousands BTUs per hour
CCR	Corrected Capacity Ratio	MCA	Maximum Circuit Ampacity
CDOA	Coupled Dedicated Outdoor Air	MFS	Maximum Fuse Size
CFM	Cubic Feet per Minute	NEC	National Electrical Code
CR	Combination Ratio	OAT	Outdoor Air Temperature
DB	Dry Bulb	ODU	Outdoor Unit
dB(A)	Decibels with "A" frequency weighting	OUCF	Outdoor Unit Correction Factor
DDOAS	Decoupled Dedicated Outdoor Air	PDI	Power Distribution Indicator
DFS	Duct-Free Split	PI	Power Input
DI	Digital Input	PTAC	Packaged Terminal Air Conditioner
DO	Digital Output	PVE	Polyvinyl Ether
EEV	Electronic Expansion Valve	RAT	Return Air Temperature
ELF	Equivalent Length in Feet	RCL	Refrigerant Concentration Limit
EPDM	Ethylene Propylene Diene M-Class Rubber	SC	Sensible Capacity
ESP	External Static Pressure	TC	Total Capacity
ETL	Electronic Testing Laboratories	VAV	Variable Air Volume
HACR	Heating, Air Conditioning, and Refrigeration	VRF	Variable Refrigerant Flow
H/M/L	High / Medium / Low	VRP	Ventilation Rate Procedure

Inverter



LG Electronics, U.S.A., Inc.
Commercial Air Conditioning Division
11405 Old Roswell Road
Alpharetta, Georgia 30009
www.lghvac.com

LG Electronics Products Support
1-888-865-3026 USA
Follow the prompts for HVAC products.

EM-MultiFIDU-01-15
Supersedes EM-MultiFIDU-06-14
Supersedes DFS-EM-AJ-002-US 014A03
Supersedes DFS-EM-AJ-002-US 013M09
Supersedes DFS-EM-AJ-002-US 013K30