

Job Name/Location:

Tag #:

Date:

For:	File	Resubmit
	Approval	Other_____

PO No.:

Architect: _____ GC: _____

Engr: _____ Mech: _____

Rep: _____
(Company) (Project Manager)

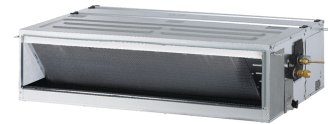

LH248HV4

Single Zone High Static Ducted

Outdoor Unit (ODU) - LUU249HV, Indoor Unit (IDU) - LHN248HV

Performance:

Cooling:

Cooling (Min~Rated~Max, Btu/h)	9,600 ~ 24,000 ~ 27,000
SEER2	16.85
EER2	11.70

SEER - Seasonal Energy Efficiency Ratio EER - Energy Efficiency Ratio

Heating:

Heating (Min~Rated~Max, Btu/h)	10,800 ~ 27,000 ~ 30,000
HSPF2	9.00

HSPF - Heating Seasonal Performance Factor

Cooling Nominal Test Conditions:

Indoor: 80°F DB / 67°F WB
Outdoor: 95°F DB / 75°F WB

Heating Nominal Test Conditions:

Indoor: 70°F DB / 60°F WB
Outdoor: 47°F DB / 43°F WB

Electrical:

Power Supply ¹ (V/Hz/Ø)	208-230/60/1
------------------------------------	--------------

Outdoor Unit:

MOP (A)	30
MCA (A)	20
Cooling Rated Amps (A)	16.7
Heating Rated Amps (A)	16.7
Compressor(A)	13.5
Fan Motor (IDU + ODU) (A)	1.6 + 1.6
Cooling Power Input (kW)	0.72 ~ 2.05 ~ 4.00
Heating Power Input (kW)	0.58 ~ 2.26 ~ 3.10

MOP - Maximum Overcurrent Protection

MCA - Minimum Circuit Ampacity

Piping:

Liquid Line (in., O.D.)	3/8
Vapor Line (in., O.D.)	5/8
Additional Refrigerant (oz./ft.)	0.43
Max. Pipe Length ² (ft.)	164
Piping Length (no add'l refrig., ft.)	24.6
Max. Elevation (ft.)	98.4

Features:

- ESP control
- Hot start
- Internal Condensate Pump
- Inverter (variable speed fan)
- Auto restart
- Control lock
- Group control
- Timer (on/off)
- Sleep Mode
- Optional Wi-Fi Control
- Aux Heater relay kit

Optional Accessories:

- MultiSITE™ CRC1 - PREMTBVC0
- MultiSITE CRC1+ - PREMTBVC1
- MultiSITE Comm. Mgr. - PBACNBTR0A
- AC Smart 5 - PACS5A000
- Simple Controller - PREMTCC00U
- Wi-Fi module with cable - PWFMD200
- ACP 5 - PACP5A000
- Low Ambient Wind Baffle (Cooling operation to -4°F) ZLABGP04A
- Dynamic V8 2VL Low Profile Air Cleaner - ZPLMV201A
- Drain Pan Heater - PQSH1200
- Dry Contact (Simple)- PDRYCB300
- Dry Contact (3rd Party) - PDRYCB300
- Dry Contact (Setback) - PDRYCB400
- PI-485 - PMNFP14A1
- High Efficiency Filter Box ZFBXM101A

Operating Range:

Outdoor Unit:

Cooling (°F DB)	5 to 118
Heating (°F WB)	-4 to 64

Indoor Unit:

Cooling (°F WB)	57 to 77
Heating (°F DB)	59 to 81

System Data:

Refrigerant Type	R410A
Refrigerant Control	EEV
Refrigerant Charge (lbs.)	4.41
ODU Sound Pressure Max (Cool / Heat) ±3 dB(A) ³	48 / 52
IDU Sound Pressure (H/M/L) ±3 dB(A) ³	37 / 35 / 34
ODU Net / Shipping Weight (lbs.)	130.0 / 143.3
IDU Net / Shipping Weight (lbs.)	58.6 / 71.9
Heat Exchanger Coating	GoldFin™

Fan:

ODU Type	Propeller
IDU Type	Sirocco
Fan Speeds (Fan/Cool/Heat)	3 / 3 / 3
Fan Quantity (ODU + IDU)	1 + 1
Motor/Drive	Brushless Digitally Controlled/Direct
ODU Air Circulation (CFM)	2,048
IDU Air Circulation (H/M/L) (CFM)	777 / 706 / 636
Default ESP (in wg)	0.24
Minimum ESP/Fan Setting Value ⁴	0.1 / 96
Maximum ESP/Fan Setting Value ⁴	0.59 / 140
Dehumidification Rate (pts/hr)	5.1

Notes:

1. Acceptable operating voltage: 187V-253V.
2. Piping lengths are equivalent.
3. Sound Pressure levels are tested in an anechoic chamber under ISO Standard 3745.
4. Maximum static pressure may result in reduced airflow (CFM).
5. All communication / connection (power) cable from the outdoor unit to the indoor unit is field supplied and is to be minimum four-conductor, 14 AWG, stranded, shielded or unshielded (if shielded, it must be grounded to the chassis of the outdoor unit only), and must comply with applicable local and national codes.
6. See Engineering Manual for sensible and latent capacities.
7. Power wiring cable size must comply with the applicable local and national code.
8. The indoor unit comes with a dry helium charge.
9. This data is rated 0 ft. above sea level, with 24.6 ft. of refrigerant line and a 0 ft. level difference between outdoor and indoor units.
10. Must follow installation instructions in the applicable LG installation manual.
11. If the optional low ambient wind baffle (ZLABGP04A) is used, one wind baffle is required for each ODU fan.



For a complete list of available accessories, contact your LG representative.

For continual product development, LG reserves the right to change specifications without notice.

© LG Electronics U.S.A., Inc., Englewood Cliffs, NJ. All rights reserved. "LG Life's Good" is a registered trademark of LG Corp. /www.lghvac.com

SB_SZ_High_Static_Ducted_LH248HV4_2022_12_09_061719

Page 1 of 3

LH248HV4
 Single Zone High Static Ducted
 Outdoor Unit (ODU) - LUU249HV, Indoor Unit (IDU) - LHN248HV



Tag No.: _____

Date: _____

PO No.: _____

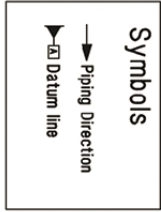

Unit: inch

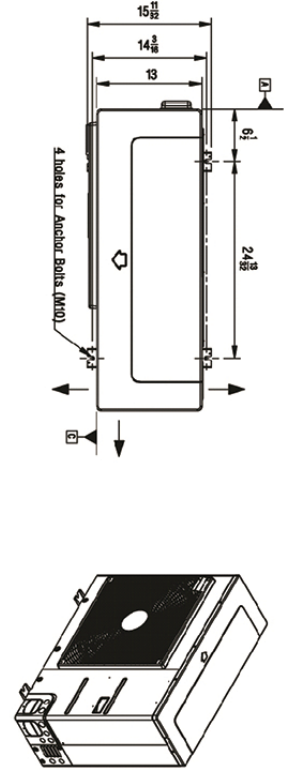
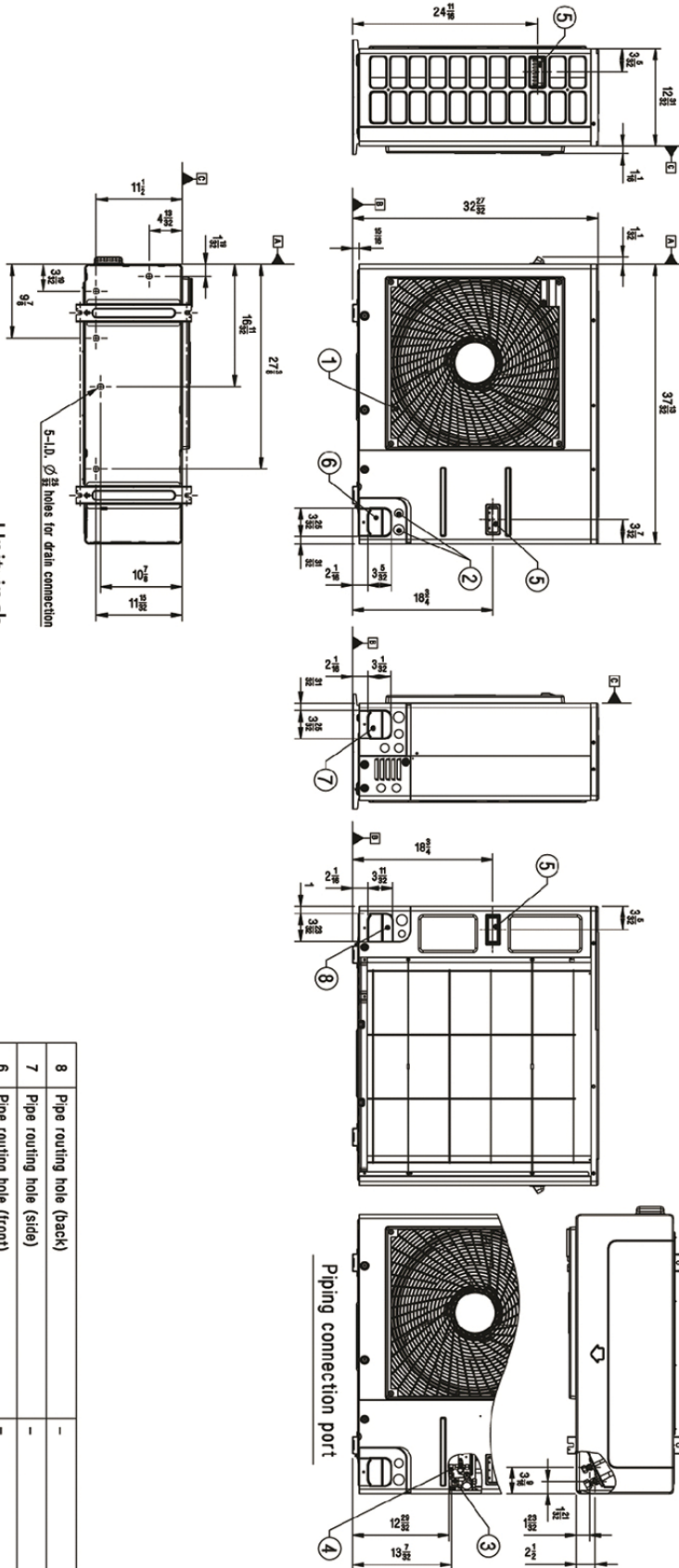

No.	Part Name	Description
8	Pipe routing hole (back)	-
7	Pipe routing hole (side)	-
6	Pipe routing hole (front)	-
5	Handle	-
4	Liquid Pipe Connection	Flare joint
3	Gas Pipe Connection	Flare joint
2	Power and communication cable Hole	-
1	Air Outlet	-

LH248HV4

Single Zone High Static Ducted

Outdoor Unit (ODU) - LUU249HV, Indoor Unit (IDU) - LHN248HV



Tag No.: _____

Date: _____

PO No.: _____

Symbols

- View Direction
- Datum line

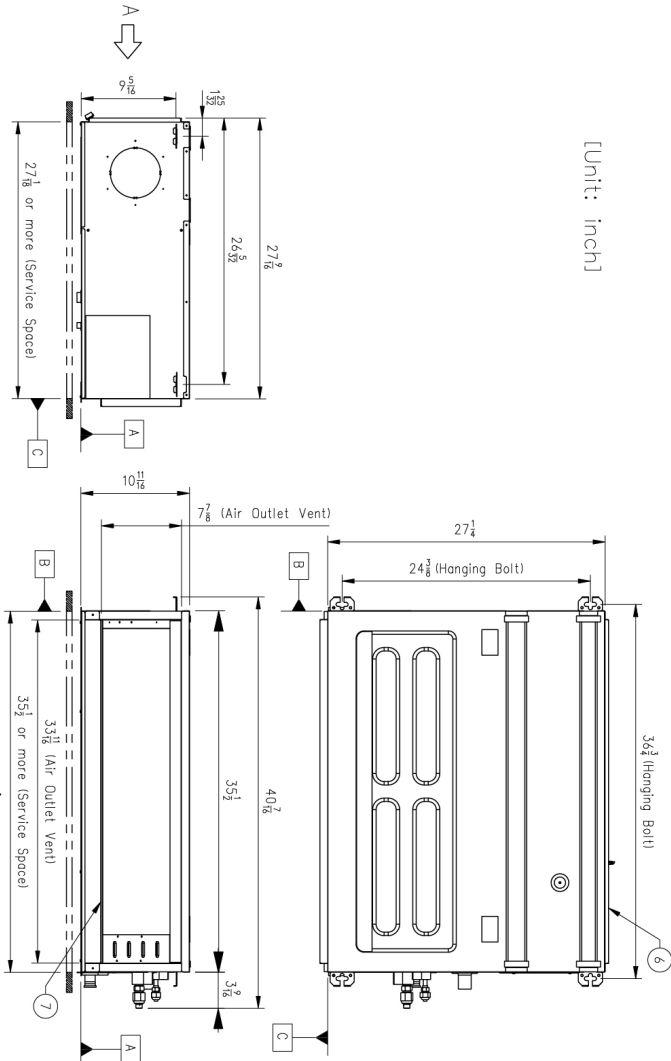
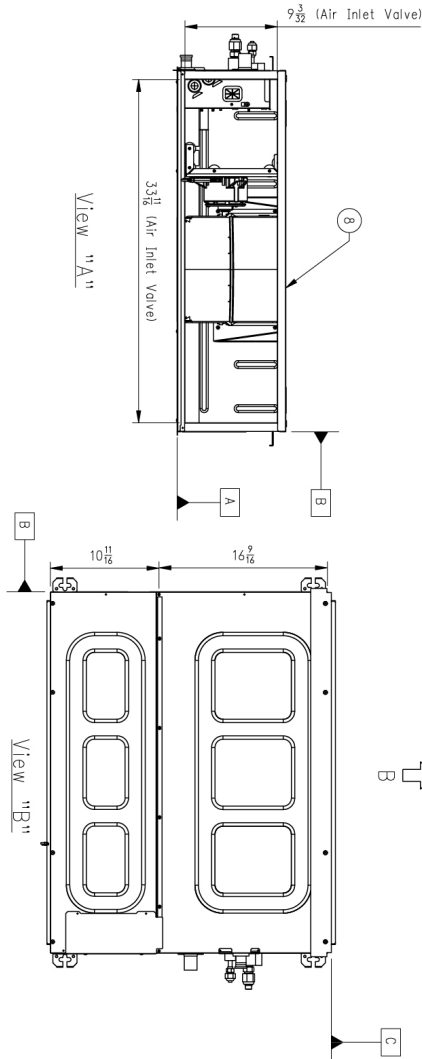

[Unit: inch]

No.	Part Name	Description
9	Control Cover	-
8	Air Filters	-
7	Air Outlet	-
6	Air Inlet	-
5	Power Cable Hole	-
4	Remote and Communication Cable Hole	-
3	Drain pipe connection	-
2	Liquid pipe connection	-
1	Gas pipe connection	-

