

Electronic Sensor Deck Mount Soap Dispenser

ROYAL SERIES



Standard Features

- Fits in Krowne Standard Trash Stations
- Perfect for narrow and compact spaces
- 3 year warranty

Specifications

Mounting Style	Deck Mount
Power Rating	DC12V / DC6V
Dispensed Amount	0.5S - 2.0S
Liquid Capacity	34 oz.
Sensor Distance	1" to 6" (Defaults 4")
Reaction Time	0.2 Second
Dispensing Time	1 Second
Nominal Working Temperature	5°C~70°C
Material	Chrome Plated Brass
Weight	2 lbs

Model	Description
16-657	Electronic Sensor Deck Mount Soap Dispenser

Product Compliance

- N/A

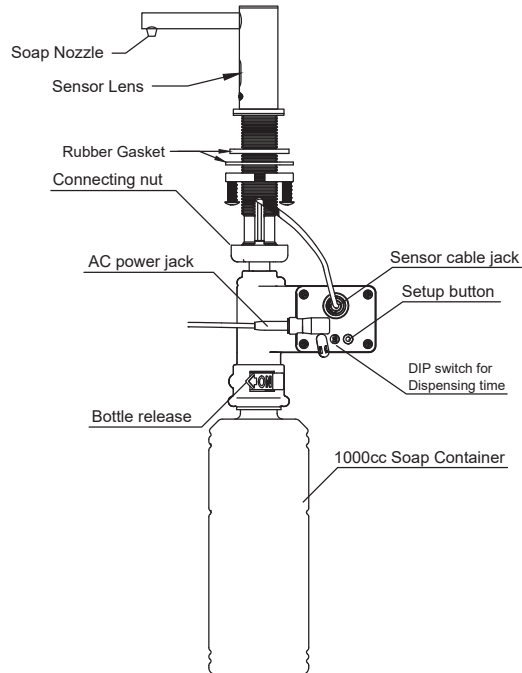
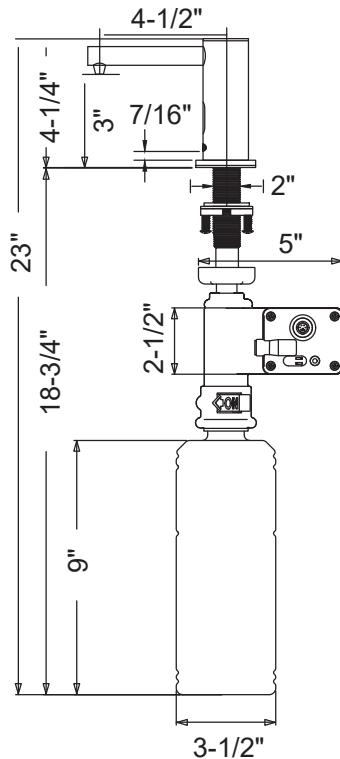

Warning:

Plumbing connections should be made by qualified personnel who will observe all applicable plumbing, sanitary and safety codes

California Prop 65 Warning:

This product can expose you to chemicals including lead and lead compounds, which are known to the State of California to cause cancer and birth defects or other reproductive harm. For more information go to www.P65Warnings.ca.gov.