

Installation Guide

Mounting

NOTE: To assemble a quick-mount "V" actuator on a valve body, see the [HPO-5074 Installation Guide](#) on the KMC web site.



MEP-4x5xV
Actuator



VFB-43 Series
Valve Body

1. Clean the lines upstream from the valve. Remove any debris larger than 0.06" (0.015 mm).
2. Align the valve's flow indicator with the system (**mixing or diverting**—see below) flow.
3. Mount the valve so the actuator is positioned over valve.

⚠ CAUTION

To prevent condensation from dripping onto the actuator housing, mount the valve with the actuator in the upright position or, at most, at a 45° angle.

4. Seal valves with approved pipe sealant.
5. Using two wrenches, secure the valve to the pipe. Torque should not exceed 75 ft-lb. (102 N•m).
6. Eliminate air from the system to keep the valves full of fluid during operation.

NOTE: If the system experiences large amounts of debris, steps should be taken to keep the system clean.

⚠ CAUTION

Using mineral oil lubricants or other incompatible substances in system fluids may damage EPDM rubber seals in valves. Before using any lubricant or additive in a water or ethylene glycol base, consult the substance manufacturer for compatibility with EPDM (Ethylene Propylene Diene Monomer).

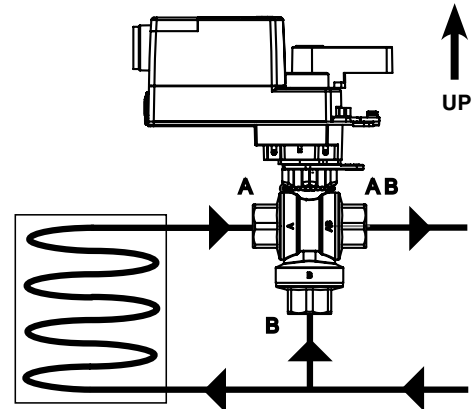

MIXING Flow Action:
Full CCW = Port A to AB
Full CW = Port B to AB

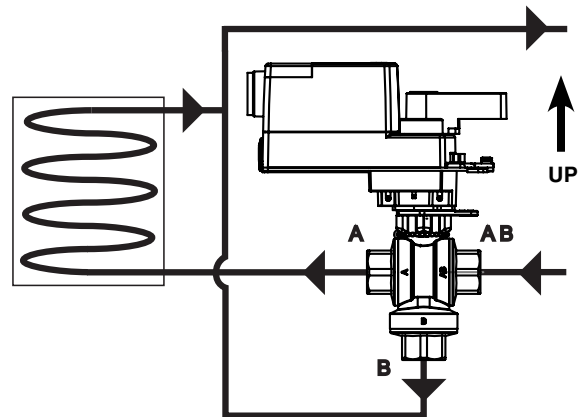

DIVERTING Flow Action:
Full CCW = Port AB to A
Full CW = Port AB to B

Operation

After the mechanical and electrical installations have been completed, cycle the actuator to verify the direction of rotation for normal operation and fail-safe if so equipped.

Maintenance

No routine maintenance is required. Each component is designed for dependable, long-term reliability, and performance. Careful installation will also ensure long-term reliability and performance.

Wiring

NOTE: The installed actuator model is indicated by the last two digits of the VEB valve model number (e.g., VEB-46xxxxCK has an MEP-4002V actuator) and the last three digits of the older VEP valve model number (e.g., VEP-43xxx745 has an MEP-4002 actuator). **For wiring and other information about tri-state and other actuators no longer sold mounted on these valves, see the respective actuator's installation guide on the KMC web site.**

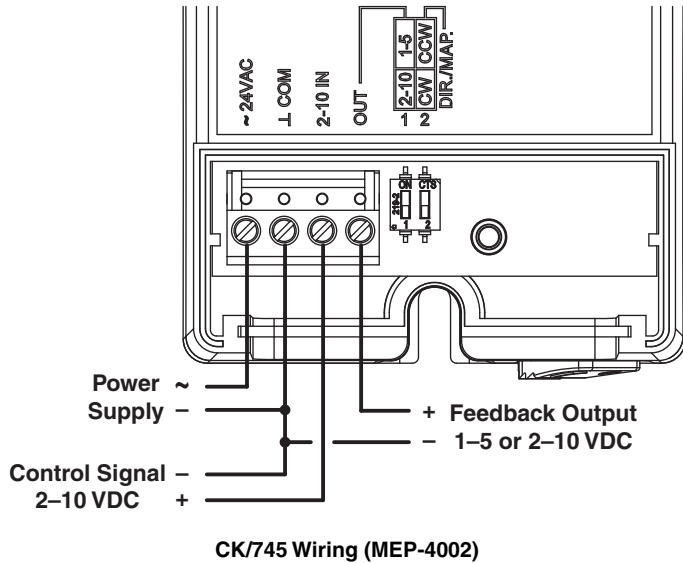

NOTE: Before January 2014, MEP-40x2/48x2 models had 0–10 VDC inputs. They now have 2–10 VDC inputs. When replacing an older 0–10 VDC actuator with a 2–10 VDC actuator, configure the connected controller or thermostat output to match.

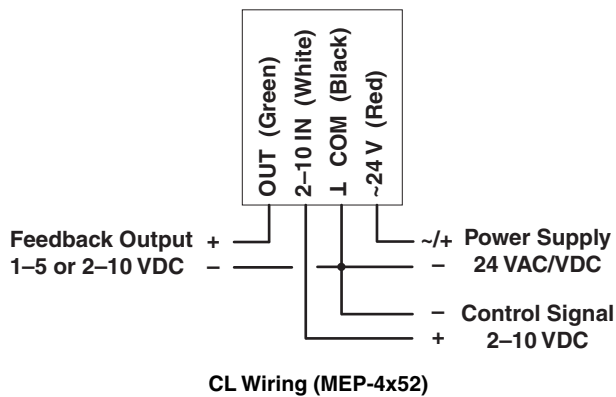

For additional instructions on wiring, feedback selector, and actuator/signal range reset (auto-mapping), see the [MEP-4000/4800 Series Installation Guide](#) or (fail-safe) [MEP-4200/4500/4900 Series Installation Guide](#).

More Information

For models, specifications, and additional information, see the [VEB-46/VFB-46 Series Data Sheet](#) on the KMC web site.



For **non-fail-safe** wiring, auxiliary switches, feedback/direction selectors, actuator/signal range reset (auto-mapping), and other information, see the [MEP-4000/4800 Series Installation Guide](#).

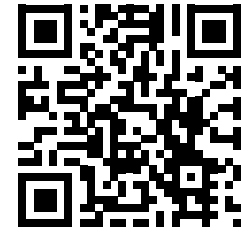

For **fail-safe** wiring, auxiliary switches, feedback/direction selectors, actuator/signal range reset (auto-mapping), and other information, see the [MEP-4200/4500/4900 Series Installation Guide](#).

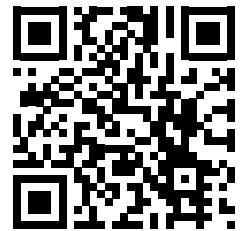

For information on assembling a quick-mount “V” actuator on a valve body, see the [HPO-5074 Installation Guide](#).

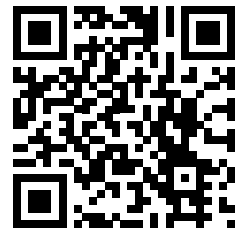

KMC Controls, Inc.
 19476 Industrial Drive
 New Paris, IN 46553
 574.831.5250
www.kmcccontrols.com
info@kmcccontrols.com