

ACTUATORS & DAMPERS

DAMPER POSITION SWITCHES

TS-470 SERIES

DESCRIPTION

The **Johnson Controls TS-470 Series** damper position switches consist of an encapsulated mercury switch mounted on a 1/2" (1.3 cm) damper shaft crank arm. The **TS1-470 Series** includes the same switch, mounted on a 1" (2.5 cm) crank arm. They are mounted on a horizontal damper shaft to provide opened/closed indication. Switch contacts are normal when the cable end of the switch is horizontal or above, and makes when the cable end drops more than 15° below horizontal.

FEATURES

- **Easy to install**
- **Easily adjustable**

SPECIFICATIONS

Wiring	
TS(1)-470	3' length, AWG 18, 3-conductor cable; green = common, black = N.C., white = N.O.
TS(1)-470-2	3' length, AWG 18, two 3-conductor cables; green = common, black = N.C., white = N.O.
TS(1)-470-P	3' length, plenum AWG 18, 3-conductor cable; black = common, blue = N.C., red = N.O. Encapsulated mercury switch, contains 0.03 cc mercury
Switch Type	
Contact Rating	SPDT; 2A @ 120 VAC, 1A @ 240 VAC
Non-plenum	SPDT; 1A @ 120 VAC, 240 VAC
-P models	
Switch Angle	Makes at 15° below horizontal
Operating Temperature	-30° to 130°F (-34° to 54°C)
Dimensions	
TS-	1.4"H x 1.0"W x 4.4"L (3.6 x 2.5 x 11.1 cm)
TS1-	1.5"H x 1.8"W x 5.5"L (3.8 x 4.5 x 14.0 cm)
Weight	
TS-	0.46 lb (0.21 Kg)
TS1-	0.8 lb (0.36 Kg)
Mounting	
TS-	1/2" (1.3 cm) damper shaft
TS1-	1" (2.5 cm) damper shaft
Warranty	
	1 year



TS-470-2



TS1-470

WIRING / DIMENSIONS

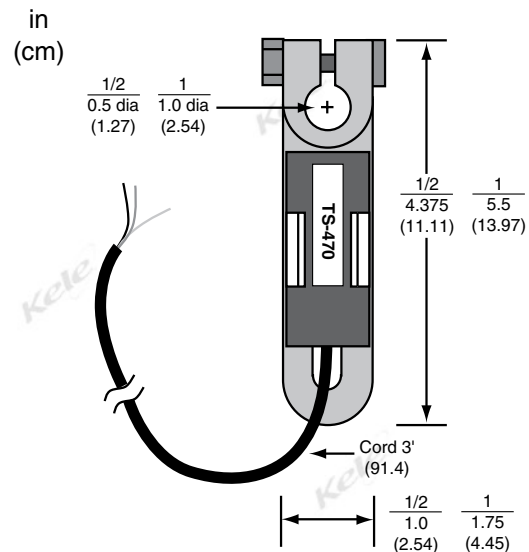

ORDERING INFORMATION

MODEL	DESCRIPTION
TS-470	Damper position switch with SPDT switch, for 1/2" shaft
TS-470-2	Damper position switch with two SPDT switches, for 1/2" shaft
TS-470-P	Damper position switch with SPDT switch, for 1/2" shaft, stainless steel housing, and plenum-rated cable
TS1-470	Damper position switch with SPDT switch, for 1" shaft
TS1-470-2	Damper position switch with two SPDT switches, for 1" shaft
TS1-470-P	Damper position switch with SPDT switch, for 1" shaft, stainless steel housing and plenum-rated cable

RELATED PRODUCTS

KLNJ-A2	Whisker switch with coated spring-rod and 10A @ 120 VAC contacts
LS45M91B11	Whisker switch with steel spring-rod and 5A @ 120 VAC contacts
TS-475	Non-mercury damper position switch, SPDT, for 1/2" damper shaft
TT-470	Tilt transducer with 1/2-in crank arm, 4-20 mA loop powered
TT1-470	Tilt transducer with 1-in crank arm, 4-20 mA loop powered