



34- 636- 2448, Rev. F
(barcode for factory use only)

M9300 Series Electric Non-Spring Return Actuators

Installation Instructions

M9308-AGA-2Z, M9308-AUA-2Z, M9310-AUA-2, M9310-HGA-2 **Part No. 34-636-2448, Rev. F**
Issued June 2017

Refer to the [QuickLIT website](#) for the most up-to-date version of this document.

Applications

IMPORTANT: Use this M9300 Series Electric Non-Spring Return Actuator only to control equipment under normal operating conditions. Where failure or malfunction of the electric actuator could lead to personal injury or property damage to the controlled equipment or other property, additional precautions must be designed into the control system. Incorporate and maintain other devices, such as supervisory or alarm systems or safety or limit controls, intended to warn of or protect against failure or malfunction of the electric actuator.

IMPORTANT : Utiliser ce M9300 Series Electric Non-Spring Return Actuator uniquement pour commander des équipements dans des conditions normales de fonctionnement. Lorsqu'une défaillance ou un dysfonctionnement du electric actuator risque de provoquer des blessures ou d'endommager l'équipement contrôlé ou un autre équipement, la conception du système de contrôle doit intégrer des dispositifs de protection supplémentaires. Veiller dans ce cas à intégrer de façon permanente d'autres dispositifs, tels que des systèmes de supervision ou d'alarme, ou des dispositifs de sécurité ou de limitation, ayant une fonction d'avertissement ou de protection en cas de défaillance ou de dysfonctionnement du electric actuator.

Installation

Parts Included

- M9300 Series actuator

Figure 1: M9300 Actuator

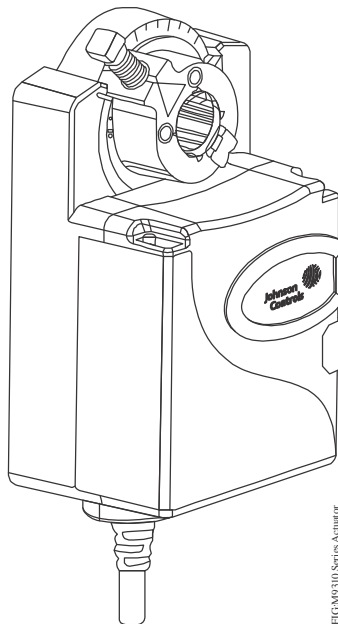

- anti-rotation bracket

Figure 2: Anti-Rotation Bracket

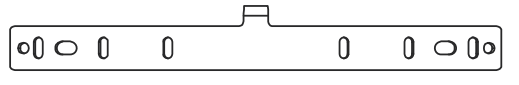

- M3.5 x 9.5 mm long self-tapping crossed recessed screw

Figure 3: Self-Tapping Screw



Special Tools Needed

- torque wrench with 12 point 3/8 in. or 5/16 in. open-end wrench
- 5/16 in. screwdriver
- digital voltmeter

Accessories

Table 1: Accessories (Order Separately)

Code Number	Description
DMPR-KC003¹	7 in. (178 mm) blade pin extension without bracket for Johnson Controls® direct-mount damper applications
M9000-322	NEMA 4x, IP66/67 Weathershield Kit for damper application of M9104, M9310, M9203, and M9208 Series Electric Actuators
M9000-400	Jackshaft Linkage Adapter Kit
M9000-604	Replacement Anti-Rotation Bracket Kit for M9310, M9203, M9208, and M9220 Series Electric Actuators
M9000-606	Position indicator (quantity 5)
M9300-1	External Auxiliary Switch Kit (one single-pole, double-throw)
M9300-2	External Auxiliary Switch Kit (two single-pole, double-throw)
M9300-100	Threaded Conduit Adapters for 1/2 in. electrician's fittings (quantity 5)
M9300-140	External Auxiliary Feedback Potentiometer 140 ohm (Optional for 140 ohm Position Feedback)
M9000-151	Remote Mounting Kit, with crank arm and damper linkage for M9108, M9116, M9124 and M9300 Series Actuators
M9300-1K	External Auxiliary Feedback Potentiometer 1k ohm (Optional for 1k ohm Position Feedback)
M9300-2K	External Auxiliary Feedback Potentiometer 2k ohm (Optional for 2k ohm Position Feedback)
M9300-10K	External Auxiliary Feedback Potentiometer 10k ohm (Optional for 10k ohm Position Feedback)
M9310-500	Ball Valve Linkage Kit for converting M9310 actuators to VA9310 actuators for operating VG1000 ball valves
M9310-600	Standard Coupler Kit, M9310 Series (round 3/8 to 3/4 in. [9 to 19 mm], square 3/8 to 5/8 in. [9 to 16 mm])

1. Furnished with the damper and may be ordered separately.

Mounting

Figure 4: Mounting Positions

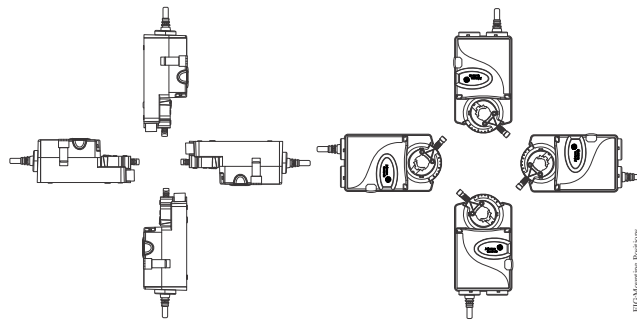

Adjusting the Angular Rotation Stops

Figure 5: Lifting the Tab

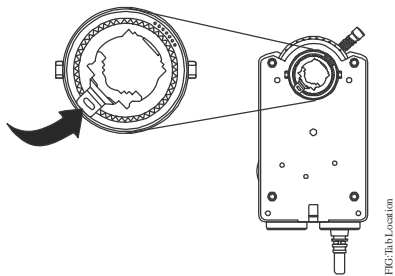

Figure 6: Rotating Coupler

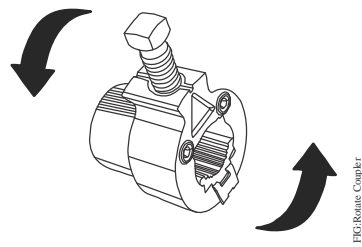

Figure 7: Removing Coupler

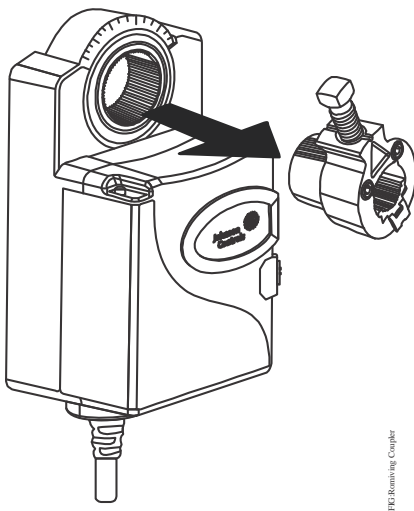
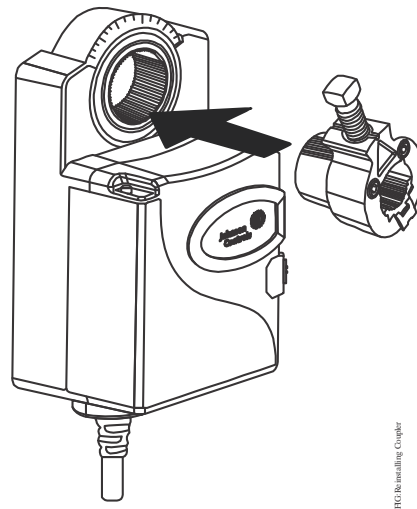

Figure 8: Installing Coupler



Mounting the Actuator

1. Position the damper until it is fully closed. See Table 2 for shaft diameters and required torques.

Figure 9: Mounting the Actuator

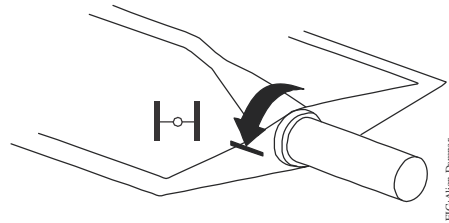

2. Bend or cut the anti-rotation bracket to fit the damper frame or duct.

Figure 10: Forming the Mounting Bracket

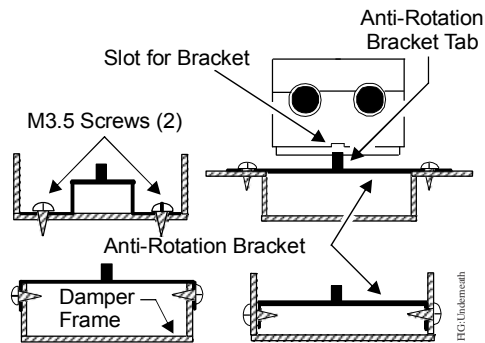

3. Load the actuator seal by rotating the shaft using the actuator (about 5 degrees).
4. Slip the actuator onto the shaft and fully tighten the set screw on the coupler according to Table 2.

Figure 11: Slipping the Actuator onto the Shaft

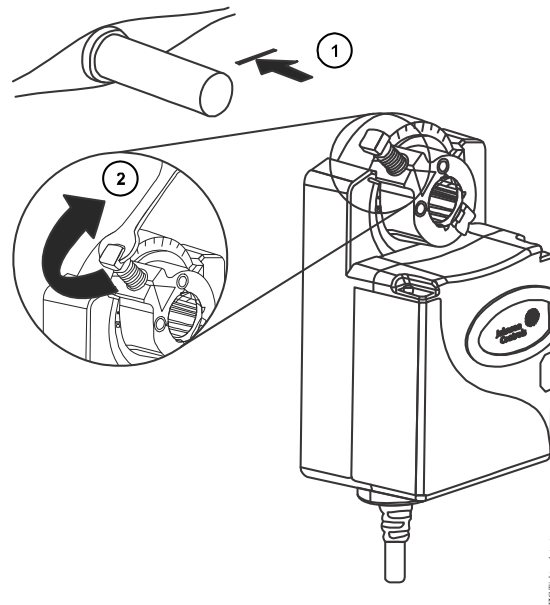
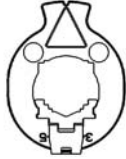
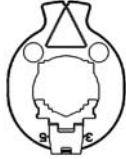
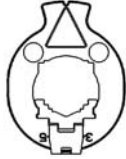
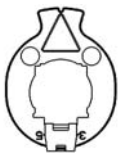

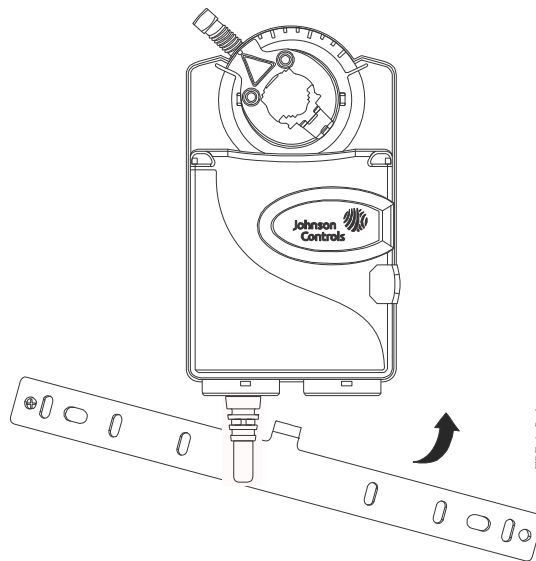

Table 2: Shaft Diameter and Required Torque

Shaft Diameter, in. (mm)	With Insert			Without Insert
				
	3/8 (9.5)	1/2 (12.7)	5/8 (16)	3/4 (19)
	5/16 (8)	13/32 (10)	1/2 (12.7)	5/8 (16)
Required Torque, lb·in (N·m)	125 (14.1)	Half-Turn Past Hand-Tighten		

- Lightly tighten one side of the anti-rotation bracket to the mounting surface.

Figure 12: Attaching the Bracket



6. Swing the anti-rotation bracket under the actuator until it reaches the middle of the slot on the bottom of the actuator.

Note: Do not position the anti-rotation bracket all the way up the slot.

Figure 13: Positioning the Anti-Rotation Bracket into the Middle of the Slot.

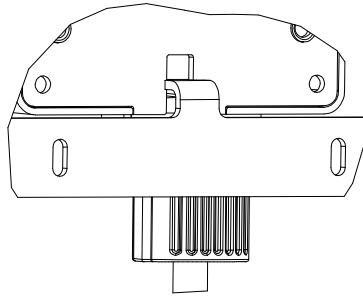
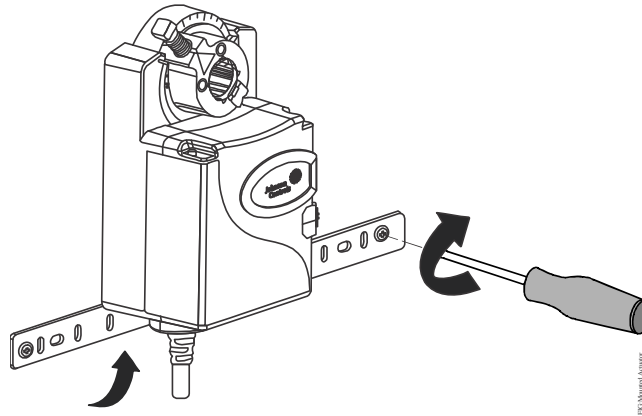
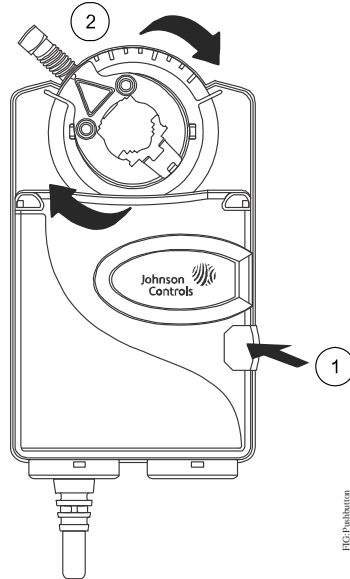

Figure 14: Securing the Anti-Rotation Bracket to the Damper Frame



7. Test the damper.
 - a. Press and hold the gear release.
 - b. Rotate the coupler fully closed to fully open to verify that the damper and actuator rotate freely throughout the range.

Figure 15: Testing the Damper



Wiring

⚠ WARNING

Risk of Electric Shock.

Disconnect the power supply before making electrical connections. Contact with components carrying hazardous voltage can cause electric shock and may result in severe personal injury or death.

⚠ AVERTISSEMENT

Risque de décharge électrique.

Débrancher l'alimentation avant de réaliser tout branchement électrique. Tout contact avec des composants conducteurs de tensions dangereuses risque d'entraîner une décharge électrique et de provoquer des blessures graves, voire mortelles.

IMPORTANT: When using the M9310-HGA-2 actuator in floating mode, verify that the DIP switch is positioned on the DC 2 to 10 V option. This setting ensures compatibility with the controller's triac output exhibiting voltage leakage. See Figure 25 for DIP switch placement.

M9308-AGA-2Z Actuators Wiring Diagrams

Figure 16: Floating 24 V Applications

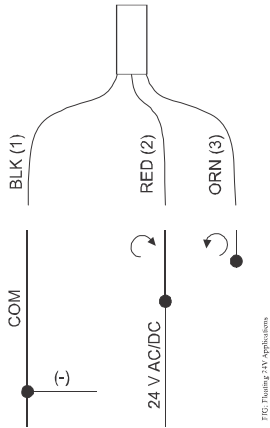
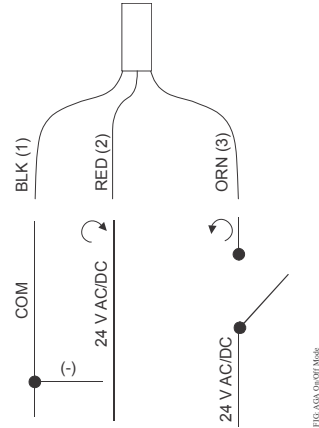

Figure 17: On/Off 24 V Applications



M9308-AUA-2Z and M9310-AUA-2 Actuators Wiring Diagrams

Figure 18: Floating 85 to 264 V Applications

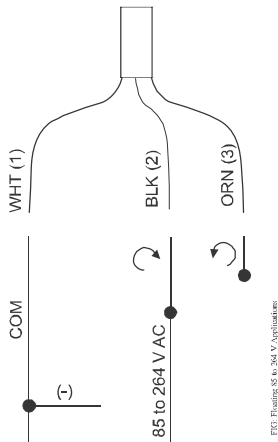
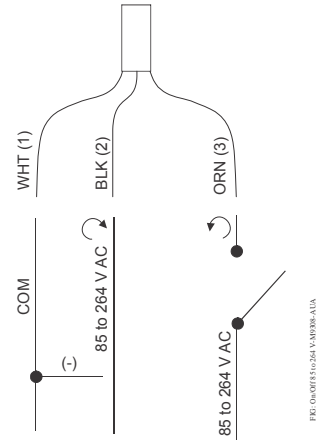

Figure 19: On/Off 85 to 264V Applications



M9310-HGA-2 Actuators Wiring Diagrams

Figure 21: On/Off 24 V Applications

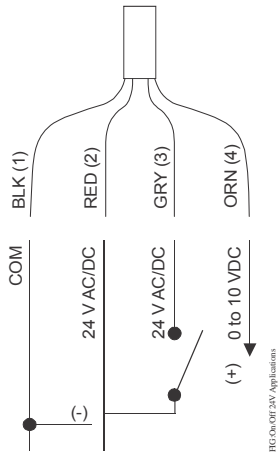

Figure 20: Floating 24 V Applications

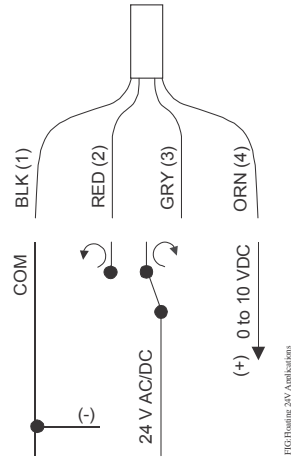

Figure 22: Proportional 24 V Applications

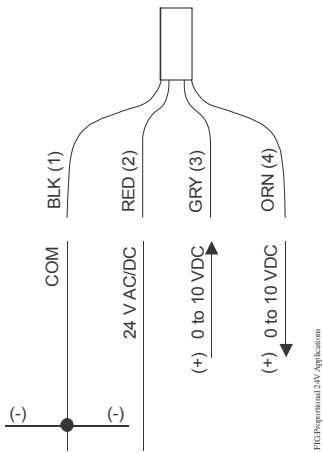
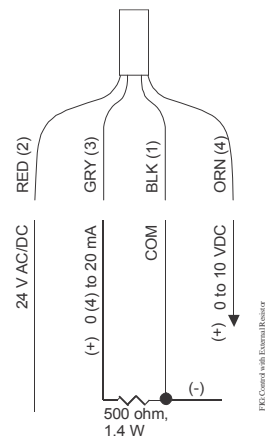

Figure 23: Proportional 24 V Applications - 0 (4) to 20 mA with External Resistor



Auto Calibration Mode (M9310-HGA-2 Only)

The actuator enters auto calibration mode and positions the coupler to the maximum and minimum end stops to identify the range of travel.

Accessing the DIP Switches and LEDs

Locate the oval cover on the front of the unit and pull the cover outward.

Figure 24: DIP Switch and LED cover

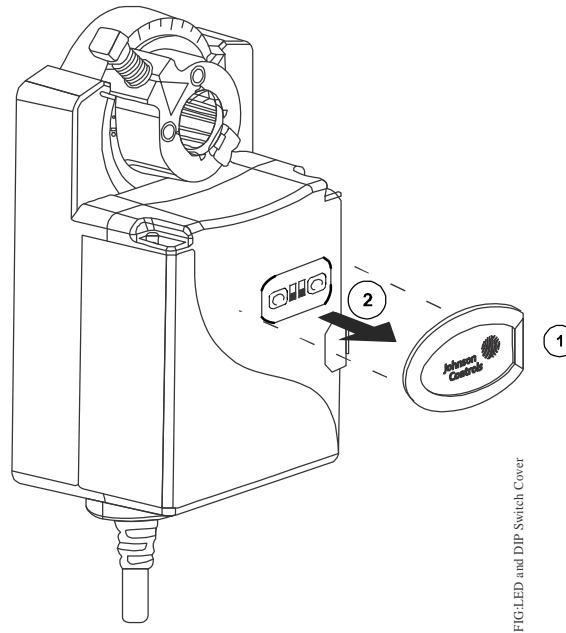

To complete the auto calibration process, press **Enter/Autocal** until all three LEDs are on. See Figure 25 for viewing the DIP switches and LEDs.

Operation

NOTICE

Risk of Property Damage.

Do not apply power to the system before checking all wiring connections. Short circuited or improperly connected wires may result in permanent damage to the equipment.

NOTICE

Risque de dégâts matériels.

Ne pas mettre le système sous tension avant d'avoir vérifié tous les raccords de câblage. Des fils formant un court-circuit ou connectés de façon incorrecte risquent d'endommager irrémédiablement l'équipement.

The valid Offset values are DC 0 to 10 V and the valid Span values are DC 2 to 10 V. The maximum feedback voltage of the actuator is DC 10 V.

Figure 25: DIP Switches and LEDs

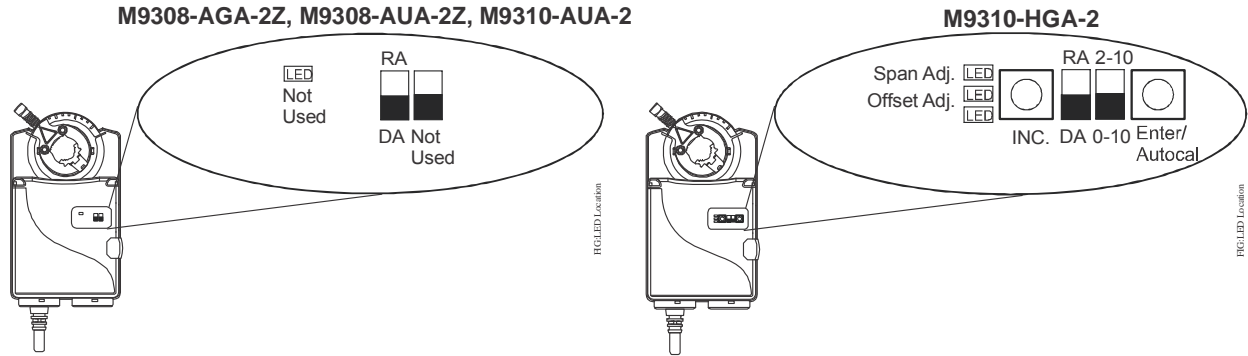

Table 3: DIP Switch Settings for M9308-AGA-2Z, M9308-AUA-2Z, M9310-AUA-2

Command Signal	Feedback Signal	Settings for User Interface
Floating or On/Off	Direct	
Floating or On/Off	Reverse	

Table 4: DIP Switch Settings for M9310-HGA-2

Example	Command Signal	Feedback Signal	Settings for User Interface
1	DC 0 to 10 V	Direct DC 0 to 10 V	
2	DC 0 to 10 V	Reverse DC 0 to 10 V	
3	DC 2 to 10 V	Direct DC 2 to 10 V	
	AC 24 V	—	
4	Offset = 5 Span = 7	Reverse DC 10 to 2 V	

Figure 26: Graphed Examples of Table 4 Command Signals

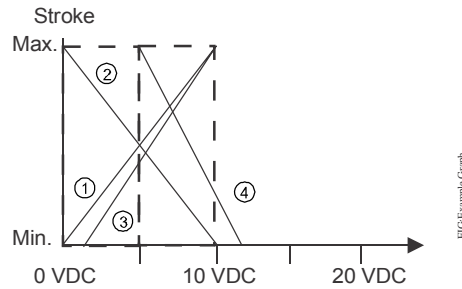

⚠ WARNING

Risk of Electric Shock.

Do not touch any exposed metal parts with anything other than properly insulated tools or insulated probes of the digital voltage meter. Failure to use properly insulated tools and probes may result in severe personal injury or death.

⚠ ADVERTISSEMENT

Risque de décharge électrique.

Ne jamais toucher une partie métallique exposée avec tout élément autre que des outils correctement isolés ou les sondes isolées du voltmètre numérique. L'utilisation d'outils et de sondes incorrectement isolés risque de provoquer des blessures graves, voire mortelles.

Setting the SPAN and OFFSET Proportional Command Signal to Other Values

1. Set DIP switch one and two before proceeding. Refer to Figure 25 for DIP switch placement.
2. Connect a digital multimeter between the orange (feedback) and black (common) wires. See [Wiring](#) for more wiring information.
3. Press **Enter/Autocal**.
To adjust the span and offset, press but not hold **Enter/Autocal**. Holding **Enter/Autocal** for longer than three seconds triggers an autocal.
The Offset Adj. LED turns on, and the multimeter displays the current offset value.
4. Press **INC**.
The Offset Adj. LED flashes. The voltage reading on the multimeter increases DC 0.5 V each time you press the button. Press **INC**. until you reach the desired voltage.
If no further action is required, the Offset Adj. LED stops flashing after 10 seconds. The actuator exits the program mode and the original offset value remains unchanged.
5. Press **Enter/Autocal**.
The Offset Adj. LED turns off indicating that the desired Offset Adj. value was recorded. The Span Adj. turns on, and the multimeter displays the present SPAN value.
6. Press **INC**.
The Span Adj. LED flashes. The voltage reading on the multimeter increases by DC 0.5 V each time you press the button. Press **INC**. until you reach the desired voltage.
If no further action is required, the Offset and Adj. LED stops flashing after 10 seconds. The actuator exits the program mode and the original offset value remains unchanged.
7. Press **Enter/Autocal**.
The Span Adj. LED turns off indicating that the desired Span Adj. setting is saved, and the actuator exits the program mode.

Reading the SPAN and OFFSET Proportional Command Signal Voltage Settings

1. Connect a digital multimeter between the orange (feedback) and black (common) wires. See [Wiring](#) for more wiring information.
2. Press **Enter/Autocal**.
The Offset Adj. LED turns on, and the multimeter displays the current offset value.

IMPORTANT: Do not press **INC**. Otherwise your observed offset voltage setting will change.

3. Press **Enter/Autocal**.
The Offset Adj. LED turns off, the Span Adj. LED turns on, and the multimeter displays the present SPAN value.

IMPORTANT: Do not press **INC**. Otherwise your observed SPAN voltage setting will change.

4. Press **Enter/Autocal**.
The Span Adj. LED turns off.

Clearing the SPAN and OFFSET Proportional Command Signal Voltage Setting

Cycle DIP switch two between 2 to 10 and 0 to 10. The active setting is the final state of DIP switch two.

Installing the Cover over the DIP Switches and LEDs

IMPORTANT: Once you have verified the DIP switch placement and LED activity, place the oval cover back onto the unit before repositioning the actuator hub.

Repositioning the Actuator Hub

1. De-energize the actuator.
2. Press the black manual override button on the side of the housing.

IMPORTANT: The manual override is automatically released when the button is released.

3. Rotate the shaft to the desired position.

Figure 27: Repositioning the Actuator Hub

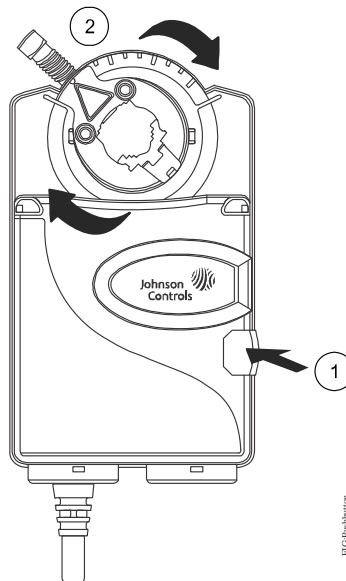

Removing the Conduit Connector

You can remove the conduit connector at the bottom of the unit if the connector is damaged. To remove the connector:

1. Insert a screwdriver into the slot on the housing.
2. Rotate the conduit connector counterclockwise and remove it from the actuator.

Figure 28: Removing the Conduit Connector

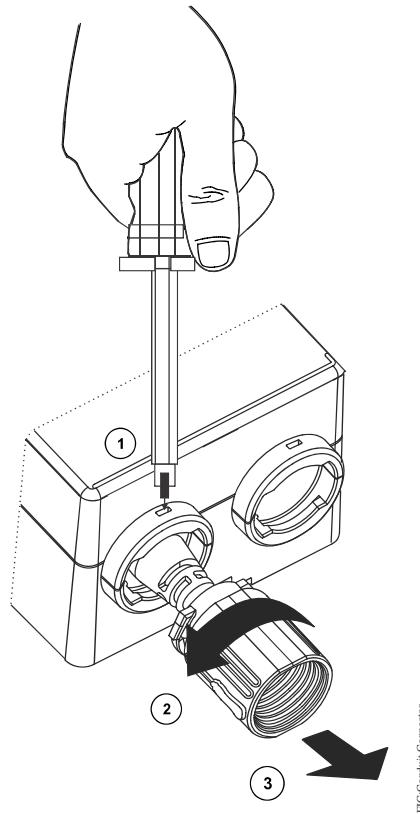

Repair Information

If the M9300 Series Electric Non-Spring Return Actuators fail to operate within its specifications, replace the unit. For a replacement actuator, contact the nearest Johnson Controls representative.

Technical Specifications

M9308-Axx-2Z and M9310-AUA-2 Series Electric Non-Spring Return Actuator

Product Description	M9308-AGA-2Z: Floating and On/Off mode	M9308-AUA-2Z: Floating and On/Off Mode	M9310-AUA-2: Floating and On/Off Mode
Power Requirements	AC 24 V \pm 20% at 50/60 Hz, Class 2 (North America) or SELV (Europe), 12.7 VA running. DC 24 V \pm 10% Class 2 (North America) or SELV (Europe), 5.7 W running.	Nominal AC 120 V at 60 Hz: 0.07 A running	Nominal AC 120 V at 60 Hz: 0.03 A running
Transformer Sizing Requirements	\geq 13 VA	—	—
Input Signal/Adjustments	AC 19.2 to 28.8 V at 50/60 Hz or DC 24 V \pm 10% Class 2 (North America) or SELV (Europe)	AC 100 to 240 V (AC 85 to 264 V) at 50/60 Hz	
Running Torque	70 lb·in (8 N·m)		90 lb·in (10 N·m)
Rotation Range	Mechanically limited to 95° \pm 3°		
Rotation Time for 90° of Travel	8 sec, constant at all operating conditions		90 sec, constant at all operating conditions
Cycles	60,000 full stroke cycles; 1,500,000 repositions		100,000 full stroke cycles; 2,500,000 repositions
Audible Noise	<52 dBA at 0 to 70 lb·in (8 N·m) load, at a distance of 39-13/32 in. (1m)		<35 dBA at 39-13/32 in. (1m)
Electrical Connections	120 in. (3.05 m) UL 444 type CMP plenum rated cable with 19 AWG (0.75 mm ²) conductors and 0.25 in. (6 mm) ferrule ends	48 in. (1.2 m) Halogen Free Cable with 18 AWG (0.82 mm ²) conductors and 0.25 in. (6mm) ferrule ends	
Conduit Connections	1/2 in. NPSM (13 mm) threaded conduit connectors with M9300-100 conduit connector (optional with the M9308-AGA-2Z)		
Ambient Conditions	Operating: -22 to 140°F (-30 to 60°C), 95% RH, noncondensing Storage: -40 to 185°F (-40 to 85°C), 95% RH, noncondensing		
Enclosure	IP54/NEMA 5		
Shipping Weight	2 lb (0.9 kg)		
Compliance	United States: UL Listed, CCN XAPX, File E27734; to UL 60730-1: Automatic Electrical Controls for Household and Similar Use, Part 1; and UL 60730-2-14: Part 2, Particular Requirements for Electric Actuators. Plenum Rated (UL 2043). Suitable for use in Other Environmental Air Space (Plenum) in accordance with section 300.22 (c) of the National Electrical Code.		
	Canada: UL Listed, CCN XAPX7, File E27734; to CAN/CSA E60730-1:02: Automatic Electrical Controls for Household and Similar Use, Part 1; and CAN/CSA-E60730-2-14, Particular Requirements for Electric Actuators.		
	Europe: CE Mark—Johnson Controls declares that this product is in compliance with the essential requirements and other relevant provisions of the EMC Directive and the Low Voltage Directive.		
Australia and New Zealand: RCM Mark, Australia/NZ Emissions Compliant			

M9310-HGA-2 Series Electric Non-Spring Return Actuator

Product Description	M9310-HGA-2: On/Off and floating mode	M9310-HGA-2: Proportional mode
Power Requirements	AC 24 V $\pm 20\%$ at 50/60 Hz, Class 2 (North America) or SELV (Europe), 4.7 VA running; DC 24 V $\pm 10\%$ Class 2 (North America) or SELV (Europe), 1.3 W running	
Transformer Sizing Requirements	≥ 6 VA	
Input Signal/Adjustments	AC 19.2 to 28.8 V at 50/60 Hz or DC 24 V $\pm 10\%$ Class 2 (North America) or SELV (Europe)	DC 0 (2) to 10 V or 0 (4) to 20 mA with field furnished 500 ohm 1/4 W resistor Offset: DC 0 to 10 V SPAN: DC 2 to 10 V
Control Impedance	4.7k ohm	100k ohm
Feedback Signal	—	DC 0 (2) to 10 V
Running Torque	90 lb·in (10 N·m)	
Rotation Range	Mechanically limited to $95^\circ \pm 3^\circ$	
Rotation Time for 90° of Travel	90 seconds, constant for all operating conditions	
Rotation Time Auto-calibration	35 seconds	
Cycles	100,000 full stroke cycles; 2,500,000 repositions	
Audible Noise	<35 dBA at 0 to 90 lb·in (10 N·m) load, at a distance of 39-13/32 in. (1 m)	
Electrical Connections	120 in. (3.05 m) UL 444 type CMP plenum rated cable with 19 AWG cable (0.75 mm ²) conductors and 0.25 in. (6 mm) ferrule ends	
Conduit Connections	1/2 in. NPSM (13 mm) threaded conduit connectors with M9300-100 conduit connector (optional with the M9310-HGA-2)	
Ambient Conditions	Operating: -22 to 140°F (-30 to 60°C), 95% RH, noncondensing Storage: -40 to 185°F (-40 to 85°C), 95% RH, noncondensing	
Enclosure	IP54/NEMA 5	
Shipping Weight	2 lb (0.9 kg)	
Compliance	<p>United States: UL Listed, CCN XAPX, File E27734; to UL 60730-1: Automatic Electrical Controls for Household and Similar Use, Part 1; and UL 60730-2-14: Part 2, Particular Requirements for Electric Actuators. Plenum Rated (UL 2043). Suitable for use in Other Environmental Air Space (Plenum) in accordance with section 300.22 (c) of the National Electrical Code.</p> <p>Canada: UL Listed, CCN XAPX7, File E27734; to CAN/CSA E60730-1:02: Automatic Electrical Controls for Household and Similar Use, Part 1; and CAN/CSA-E60730-2-14, Particular Requirements for Electric Actuators.</p> <p>Europe: CE Mark—Johnson Controls declares that this product is in compliance with the essential requirements and other relevant provisions of the EMC Directive and the Low Voltage Directive.</p> <p>Australia and New Zealand: RCM Mark, Australia/NZ Emissions Compliant</p>	

The performance specifications are nominal and conform to acceptable industry standard. For application at conditions beyond these specifications, consult the local Johnson Controls office. Johnson Controls shall not be liable for damages resulting from misapplication or misuse of its products.

European Single Point of Contact:

JOHNSON CONTROLS
WESTENDHOF 3
45143 ESSEN
GERMANY

NA/SA Single Point of Contact:

JOHNSON CONTROLS
507 E MICHIGAN ST
MILWAUKEE WI 53202
USA

APAC Single Point of Contact:

JOHNSON CONTROLS
C/O CONTROLS PRODUCT MANAGEMENT
NO. 22 BLOCK D NEW DISTRICT
WUXI JIANGSU PROVINCE 214142
CHINA



Building Technologies & Solutions
507 E. Michigan Street, Milwaukee, WI 53202

*Metasys® and Johnson Controls® are registered trademarks of Johnson Controls.
All other marks herein are the marks of their respective owners. © 2017 Johnson Controls.*

M9300 Series Electric Non-Spring Return Actuators Installation Instructions