



FM1D14 Series 24-Hour/7-Day Time Switch Operation and User Instructions

⚠ WARNING Risk of Fire or Electric Shock

- Disconnect power prior to installation.
- Connect FM1D14 wiring in accordance with all applicable national and local electrical code requirements.

Specifications

Input

- 12 VDC (FM1D14-12)
- 24 VAC and VDC, 50/60 Hz (FM1D14-24)
- 120-277 VAC, 50/60 Hz (FM1D14-AV)

Output

NO Contact

- General Purpose: 15 A, 277 VAC
- Tungsten: 1000 W, 120 VAC
- Ballast : 8 A, 277 VAC
- Pilot Duty: B300
- Electronic Ballast: 4.9 A, 120 VAC
- Motor: 10 FLA, 60 LRA @ 250 VAC; ½ HP, 120 VAC; 1 HP, 250 VAC

NC Contact

- General Purpose: 15 A, 277 VAC
- Resistive: 12 A, 24 VDC
- Ballast : 8 A, 120 VAC
- Motor: 10 FLA, 60 LRA @ 250 VAC; ½ HP, 120/240 VAC

- Operating Temperature: -40° F to 135° F (-40° C to 55° C)
- Carry-over: 2500 hours fully charged

Description

This manual provides installation and programming instructions for the FM1D14 series timer.

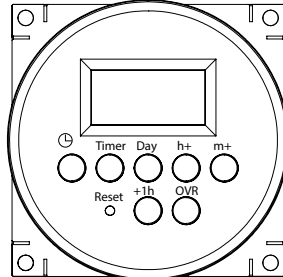

Figure 1. FM1D14 Timer

Mounting the FM1D14 Series Timer

The standard FM1D14 timer can be surface mounted inside a panel or flush mounted. Mount the timer as required. Refer to the dimension drawing in Figure 2.

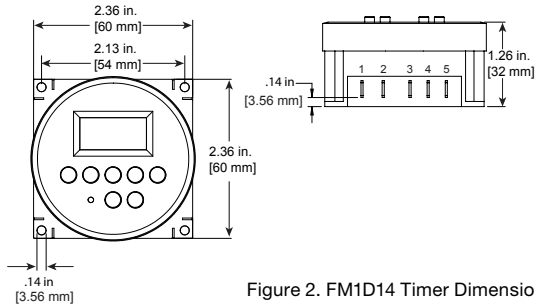

Figure 2. FM1D14 Timer Dimensions

Connecting the FM1D14 Series Timer Wiring

Follow this procedure to connect the FM1D14 timer wiring.

1. Make sure supply power is disconnected.
2. Check input and output ratings marked on timer to verify the product is suitable for your supply voltage, load, and application.
3. Connect the FM1D14 wiring. See Figure 3 for reference.

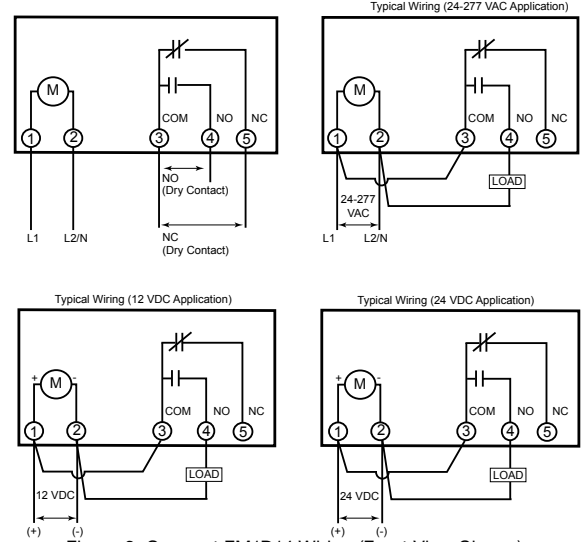

Figure 3. Connect FM1D14 Wiring (Front View Shown).

Setting the Time of Day

Follow this procedure to set the time of day and day of the week.

1. Press and release the **Reset** button with a blunt object to reset the unit. The timer screen flashes.
2. Press and hold **⌚** and **h+** simultaneously to access the **12:00 AM** screen.
3. Take one of these actions.

| If... | Then... |
|--|--|
| Your time zone currently is in Daylight Saving Time, | Press the +1h button. Go to step 4. |
| Your time zone is not in Daylight Saving Time, | Go to step 4 to set the current time. |

4. Press and hold **⌚** and press **h+** repeatedly until you advance to the current hour.
5. Press and hold **⌚** and press **m+** repeatedly until you advance to the current minute.
6. Press and hold **⌚** and press **Day** repeatedly until you advance to the current day.

Programming Events

To set ON/OFF event pair, set ON event and then repeat procedure to set OFF event. The timer enables up to 7 ON/OFF event pairs.

1. Press the **Timer** button. Dashed lines appear to indicate no event is set for event 1.

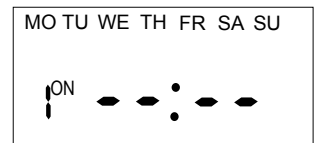

2. Press **Day** to select the days of the week for the ON event.

NOTE: To set the ON event:

| | |
|---------------------------|---|
| ON a Specific Day | Select: The desired day |
| Every Day of Week | Select: MO, TU, WE, TH, FR, SA, SU |
| Every Weekday: | Select: MO, TU, WE, TH, FR |
| Every Weekend: | Select: SA, SU |
| Monday through Saturday | Select: MO through SAT |
| Monday, Wednesday, Friday | Select: MO, WE, FR |

3. Press **h+** to scroll to the desired hour for ON event.
4. Press **m+** to scroll to the desired minute for the ON event.
5. Press **Timer** to advance to the OFF event screen.
6. Press **Day** to select the days of the week for the OFF event.
7. Press **h+** to scroll to the desired hour for the OFF event.
8. Press **m+** to scroll to the desired minute for the OFF event.

Take one of these actions.

| If... | Then... |
|--|---|
| You need to program another ON/OFF event pair, | Press Timer to advance to the next event ON screen and repeat steps 2 through 8. |
| All the required ON/OFF events are programmed, | Press ⏻ to return main screen. The procedure is complete. |

NOTE: If events include or intersect with each other, each ON/OFF event can be independently executed at the setpoint.

NOTE: If an ON event and OFF event occur at the same time, the timer will run the OFF event.

Daily Operation

Below is an overview of the different operation modes for FM1D14.

| Mode | Timer Display | Description |
|----------|---------------|---|
| Auto ON | | Appears when an ON setpoint has been triggered |
| Auto OFF | | Appears when an OFF setpoint has been triggered |
| OVR ON | | Indicates relay has been overridden to ON status |
| OVR OFF | | Indicates relay has been overridden to OFF status |

NOTE: To execute an ON/OFF status override, press the **OVR** button on the timer to override an ON or OFF status. The override remains active until the next programmed event.

Modifying an Event

Follow this procedure to review or modify an event.

1. Press **Timer** to scroll to ON or OFF event you want to modify.
2. Take one of these actions.

| If you want to modify the... | Then... |
|------------------------------------|---|
| Days of the week for ON/OFF event, | Press Day repeatedly to scroll to desired days of the week Go to step 3. |
| Hour for ON or OFF event, | Press h+ to scroll to desired hour Go to step 3. |
| Minute for ON or OFF event, | Press m+ to scroll to desired minute Go to step 3. |

3. Repeat steps 1 and 2 as needed to modify additional events.
4. When all the desired events are modified, press **⏻** to confirm event settings and return to the time of day screen.

Deleting an Event

Follow this procedure to delete an event.

1. Press **Timer** to scroll to ON or OFF event you want to delete.
2. Press **OVR** to delete the event. Dashed lines appear in place of the time to indicate the event is deleted.
NOTE: If necessary, repeat this procedure to delete both ON and OFF settings for the event.
3. When the modifications are complete, press **⏻** to return to time of day screen.

Retrieving an Event

The timer enables deleted events to be retrieved. All deleted events can be retrieved until a new event is programmed in place of event.

1. Press **Timer** to scroll to the ON/OFF event you previously deleted. Dashed lines appear in place of the event time.
2. Press **OVR** to retrieve deleted event. The event ON or OFF time replaces the dashed line indicating that the event is retrieved.
NOTE: If necessary, repeat this procedure to retrieve both ON and OFF settings for the event.
3. When the modifications are complete, press **⏻** to return to time of day screen.

Adjusting Daylight Saving Time

Press **+1h** button to add the Daylight Saving Time hour to the current time or remove the hour to return to standard time.

NOTE: Do not perform this procedure if your area does not use Daylight Saving Time.

Resetting the Timer

In case of a timer malfunction or to delete all previous settings, the unit can be reset.

To reset the timer, use a blunt pointed object to press **Reset** as shown in Figure 4. The timer resets and **deletes all the settings in the unit.**

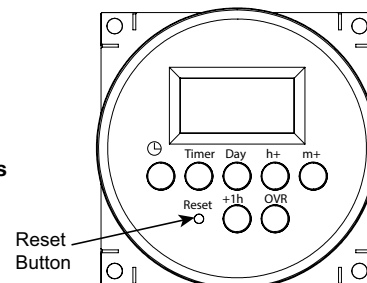

Figure 4. Reset Button

Overview of FM1D14 Power Loss Functions

In the event of a power loss, the FM1D14 does the following:

- Relay will be in the OFF state.
- Upon power restore, relay will go to the current programmed state.

LIMITED WARRANTY

Warranty service is available by either (a) returning the product to the dealer from whom the unit was purchased or (b) completing a warranty claim online at www.intermatic.com. This warranty is made by: Intermatic Incorporated, 1950 Innovation Way, Suite 300, Libertyville, IL 60048. For additional product or warranty information go to: <http://www.intermatic.com> or call 815-675-7000.

INTERMATIC INCORPORATED
LIBERTYVILLE, ILLINOIS 60048
www.intermatic.com