

**Go Beyond & Push Bathroom Exhaust Past the Fascia**

**SoffitFlow**<sup>TM</sup>

**Smart Bathroom Venting**

## Exhaust Humid Air

Advanced design features and durable construction make SoffitFlow<sup>TM</sup> the safer choice for soffit venting. Its smart, removable grill helps prevent pest intrusion. An integrated gravity assisted damper fits tightly to help keep air moving in the right direction. The bottom weep hole lets water from condensation escape to help minimize algae or mold build-up.



Smart Bathroom Venting  
Model SFV410

## Quality Construction

SoffitFlow is constructed from high-density polyethylene (HDPE), a material known for its exceptional durability and performance. SoffitFlow's durable three-piece design allows for easy access, quick removal, and simple cleaning.

## How It Works

The patented SoffitFlow works much like a car's exhaust pipe, pushing toxic fumes past the rear of a car. The system pushes warm moist air out past the fascia.

## Attic Ventilation

Traditional soffit vents can allow moisture to linger near the attic, affecting humidity levels and can lead to the growth of dangerous mold. The SoffitFlow vent is designed to guide humid exhaust air beyond the fascia, directing it away from the home.

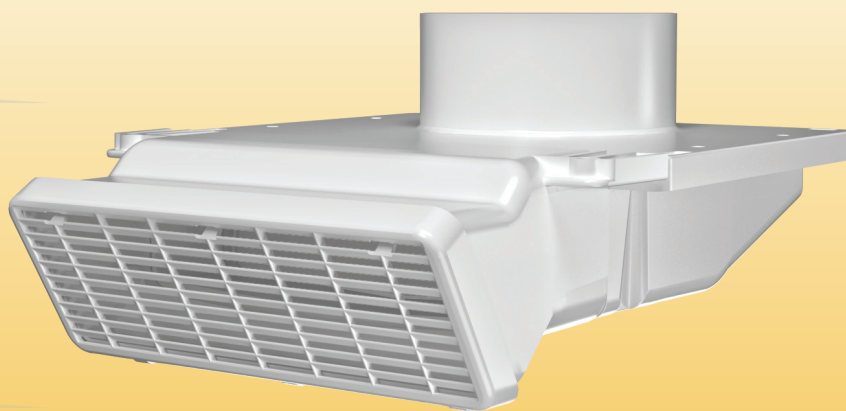

**INOVATE**<sup>®</sup>

**888-443-7937**

**SoffitFlow.com**

250 South Central Boulevard • Suite 207 • Jupiter FL 33458-8812 • Fax: 561-745-9723



# Technical Product Specifications

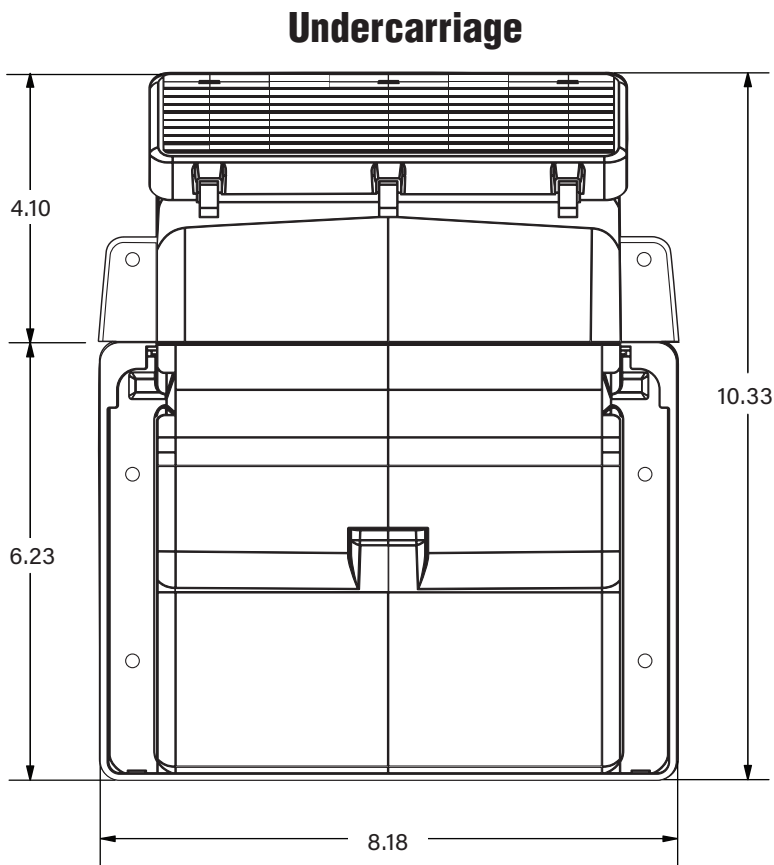
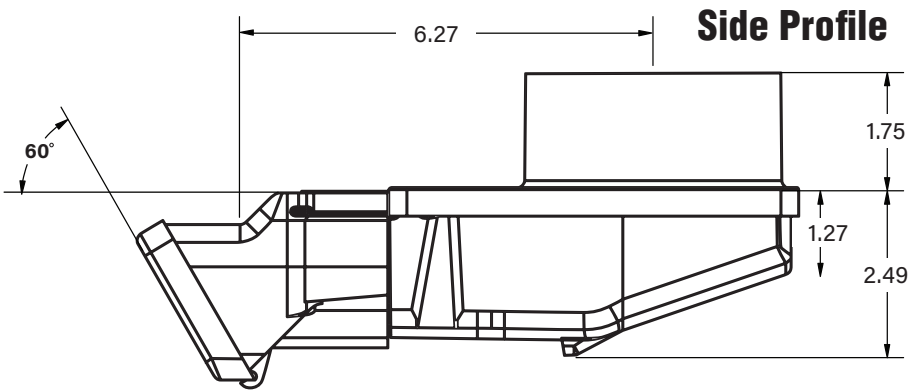

Model Number		Color
SFV410		White
Performance Data		
<b>Product Use:</b> <ul style="list-style-type: none"> <li>• Directs Bathroom Exhaust Beyond the Soffit</li> <li>• Prevents Humid Air from Recirculating Through The Attic's Passive Ventilation System</li> </ul>		
<b>Materials:</b> <ul style="list-style-type: none"> <li>• High-Density Polyethylene (HDPE)</li> </ul>		
<b>Carton Weight:</b> SFV410: 1 lbs. (Unit)   SFV410: 6.5 lbs. (6/carton)		
General Information		
<b>Benefits:</b> <ul style="list-style-type: none"> <li>• Deters Pest Entry</li> <li>• Prevents Mold and Moisture Damage</li> <li>• ICC and IRC code Compliant for Ventilation</li> <li>• Installs Easily in New and Existing Construction</li> <li>• Enhances Ventilation by Supporting Attic Airflow</li> <li>• Durable Construction to Protect Against the Elements</li> </ul>		
<b>Features:</b> <ul style="list-style-type: none"> <li>• Weep Hole Placement to Remove Water Accumulation</li> <li>• Larger Vent Opening for Better Air Flow 12.5 Sq. In.</li> <li>• Works With Pitches Ranging From 2/12 to 12/12</li> <li>• Four Mounting Holes for Easy Installation</li> <li>• Removable Grill For Easy Maintenance</li> <li>• Constructed of Durable HDPE</li> <li>• Angled Gravity Assist Damper</li> <li>• 4" Duct Compatible</li> </ul>		
Distributed By		
<b>InOvate®</b> 250 S. Central Blvd. Suite 207 Jupiter, FL 33458 Phone: (888) 443-7937 Fax: (561) 745-9723 <a href="https://SoffitFlow.com">https://SoffitFlow.com</a>		

