



Project Name:

IW-25-4 IN Wall DEHUMIDIFIER

Specification Submittal Data Sheet



The IW-25-4 Dehumidifier utilizes its integral humidistat to monitor the environmental conditions. When the relative humidity goes above the selected set point, the dehumidifier will energize. Air is drawn across an evaporator coil, which is cooler than the dew point of air. This means moisture will condense out of the air. The air is then reheated through the condenser coil and distributed back into the room. The IN Wall dehumidifier is designed for recessed wall mounting. For semi-recessed applications an IDS Exterior Sleeve (sold separately) shall be used.

- Tamper-Proof Cover** secured with signature screws
- Automatic Restart** in the event of a power outage
- LED Indicator Lamp** signals when filter needs to be maintained
- MERV 8 Washable Filter** easily accessed for cleaning
- Micro-channel Condenser Coil** used to pull in moisture from air
- All Aluminum Evaporator Coil** increases strength and longevity
- Alternate Power and Drain Routing** to ensure proper placement
- 5 Year Warranty** on Parts & Labor

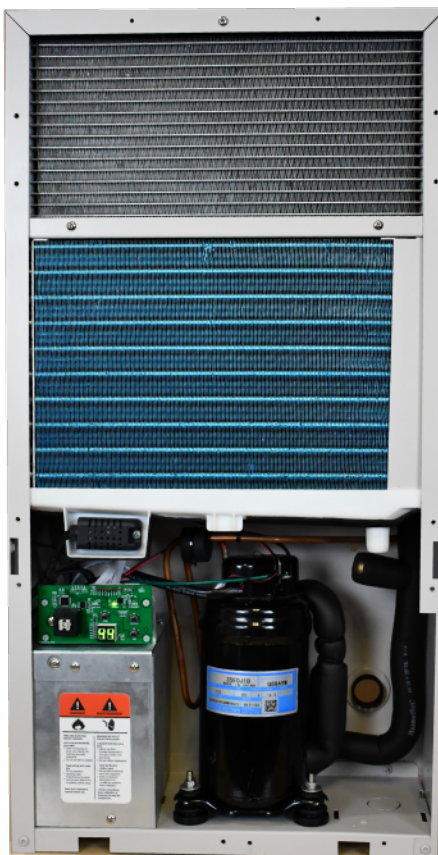

IN Wall Dimensions.....	LxWxD
Base Unit	27.625" (27 5/8") x 14.25" (14 1/4") x 5.75" (5 3/4")
IN-Wall Cover	30.375" (30 3/8") x 17.25" (17 1/4") x 1.5" (1 1/2")
IN-Wall Rough Opening	28.0" x 14.5" (14 1/2") x 5.75" (5 3/4")
Base Unit & IN-Wall Cover.....	30.375" (30 3/8") x 17.25" (17 1/4") x 7.25" (7 1/4")
Exterior Sleeve (sold separately).....	17.5" (17 1/2") x 30.5" (30 1/2") x 2.2" (2 1/5")

Part Number.....	IW-25-4 IN Wall
Weight.....	39 lbs
Rated Average Power Consumption (@ 80°F/60% RH).....	300 Watts
Max Power consumption (@ 90°F/ 95% RH).....	440 Watts
Max Absorbed Current (@ 80°F/60% RH) F.L.A.....	2.8 Amps
Locked Rotor Current L.R.A.....	14.5 Amps
Air Flow (with Clean Air Filter).....	155 cfm
Second Pressure Level (at 3 MTS in Free Field).....	45 dBA
Refrigerant R134A.....	190G
Defrosting Control System.....	Electrical
Drain Connection.....	3/4" Hose
Functioning Temperature Range.....	46-95°F
Functioning Relative Humidity Range.....	35-95% R.H.
Rated Condensation Capacity (@ 80°F/60% RH).....	up to 29.5 PPD

Specifications subject to change without notice

HumidityHappens.com



INDOOR ENVIRONMENTAL QUALITY



6260 Ocean Hwy West
Ocean Isle Beach, NC 28469

(910) 579-3348



IW-25-4 IN Wall DEHUMIDIFIER



Front View

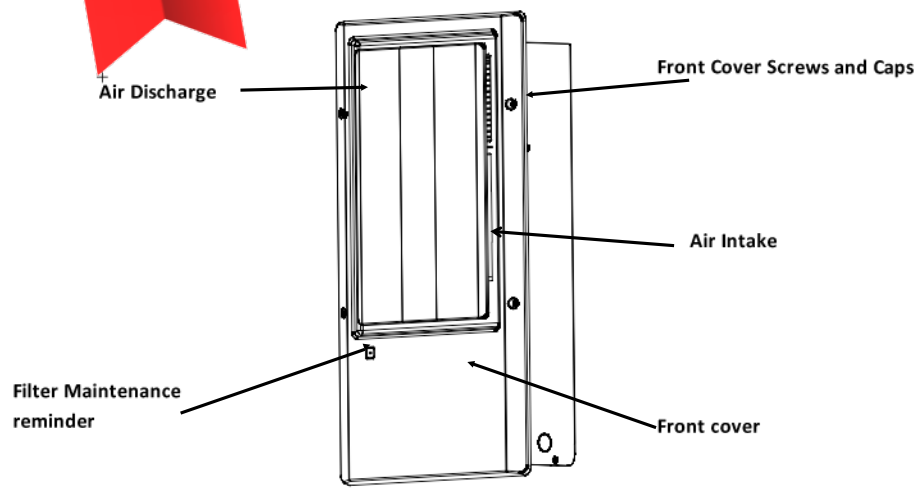

Back View

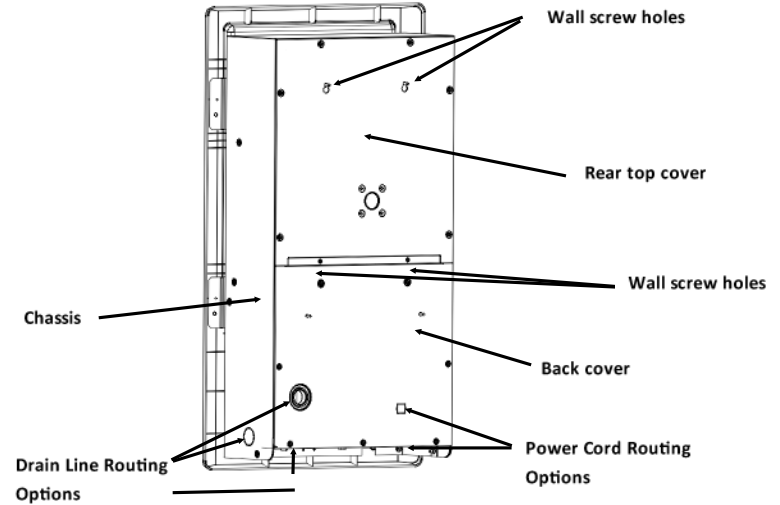

Example of Dehumidifier Placement

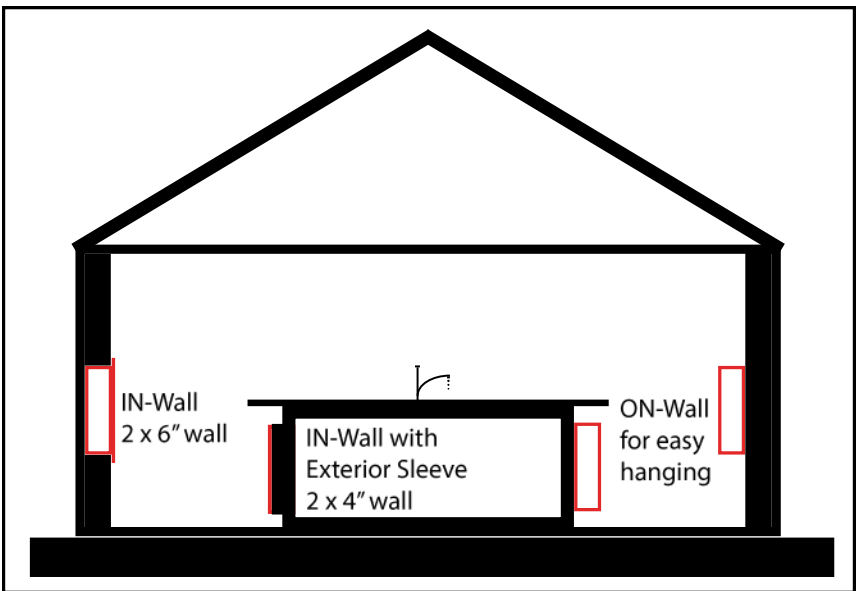

NOTE: The IW-25-4 may be installed at any height, the above example is for illustrative purposes only.

IW25-4 Optional Accessories:

Exterior Sleeve for IN Wall Dehumidifier



The Exterior Sleeve allows the IW25-4 IN Wall Dehumidifier to be semi-recessed into the wall. Includes punch out holes on side and bottom for versatile drain and power routing. The Exterior Sleeve frames the dehumidifier for a clean fit and clean aesthetic.

Dimensions: 17 1/2" x 30 1/2" x 2 1/5"

Integrated Condensate Pump Built for IW25-4



The Integrated Condensate Pump was designed for automatic collection and removal of condensate when gravity drainage is not possible or practical. Pump mounts directly into dehumidifier for tamper-proof control.

Dimensions: 7 1/8" x 3" x 2 3/4"



For Complete Installation Instructions Visit: HumidityHappens.com

(910) 579-3348