

BZD-XXXX RECTANGULAR SIDE MOUNT BAROMETRIC ZONE DAMPER

INSTALLATION INSTRUCTIONS

PATENT PENDING

INTRODUCTION

The BZD Barometric Zone Damper™ operates like any standard zone control damper but also has a built-in static pressure relief mechanism that eliminates the need for a bypass damper. If the static pressure reaches the factory preset setting, any damper that is in the closed position will start to modulate open and bleed a small amount of air into the non-calling zone. This prevents the system static pressure from rising to an unacceptable level.

INSTALLATION

1. The damper can be mounted in either a horizontal air or vertical up-flow position.
2. The airflow must be in the direction of the arrow found on the damper end plate. When the damper is mounted in the horizontal air flow position, the damper counter-weights must always be located on the bottom as illustrated below.
3. Each damper comes from the factory with the correct number of counter-weights attached to the barometric blade for horizontal air flow installation. **If the damper is mounted in a vertical up-flow position, make sure the proper number of weights are removed from the blade as shown on the included Damper Weight Chart.**
4. The damper actuator is Power Open/Power Close. The motor is rated at 24Vac, 2.5VA, 18in-lb. Terminal designations are as follows”

- 1 = Common
- 2 = Power Close
- 3 = Power Open

CONFIRM THE FOLLOWING

1. That the damper has been installed in the proper airflow direction.
2. When used for horizontal airflow, the damper must be level.
3. The weights on the blade should be at the bottom when damper is installed in a horizontal duct. When the damper is installed in a vertical up flow position, the weights need to be on the air leaving side of the damper.
4. That the proper number of weights are being used. (see Damper Weight Chart)
5. When using duct board, a filler strip is required to prevent blow-by at the back of the damper frame.
6. That the damper actuator has been wired properly.
7. That the blade is not binding. To test, drive damper closed, then rotate the damper shaft on the opposite side of the actuator to make sure the blade moves freely.
8. After proper damper installation is verified, check the discharge air static pressure. If the pressure is more than 0.3” w.c., a reduction in blower speed may be required.

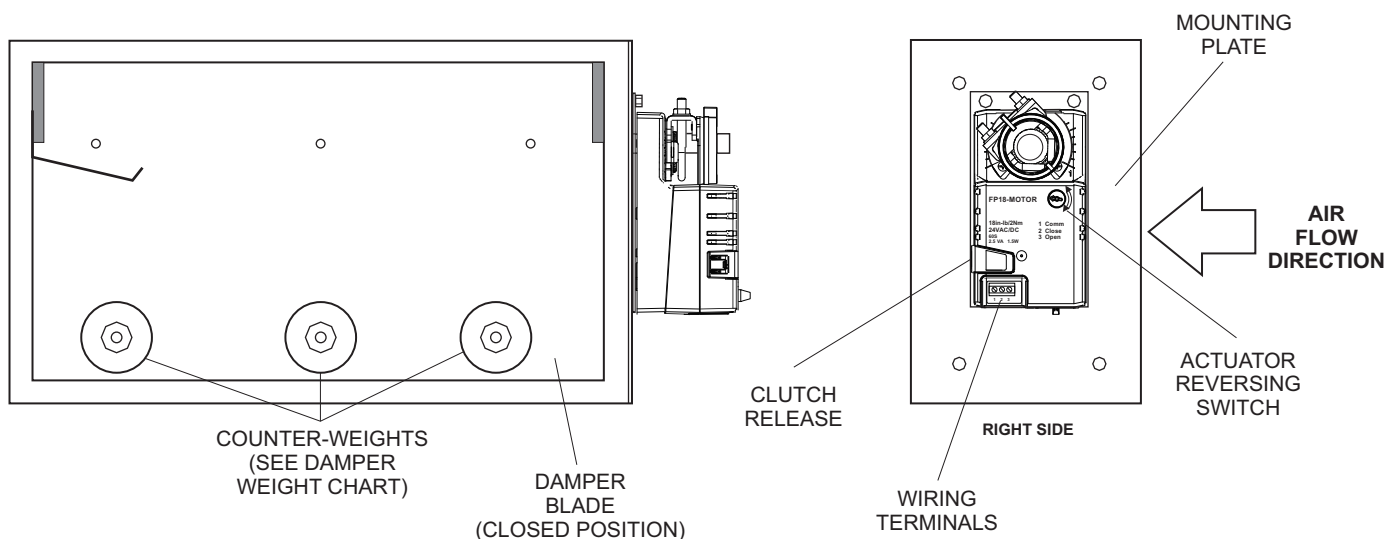

RELOCATING THE DAMPER ACTUATOR

1. Changing the damper actuator position should be done before the damper is installed in the duct.
2. The actuator assembly is factory mounted on the right side of the damper. (Refer to illustration below)
3. Place the damper in the horizontal air flow position and release the actuator clutch so that the damper travels to the closed position. The weights will be on the bottom. (See illustration on other side)
4. Remove the 4 screws holding the Damper End Plate to the Damper Frame and remove with Actuator Assembly intact.
5. Align the Damper End Plate on the other side of the damper and slide the actuator assembly onto the damper shaft drive pin.
6. Reattach the Damper End Plate using the 4 screws.
7. Rotate the actuator reversing switch to the 1 position which eliminates the need to reverse the wiring.

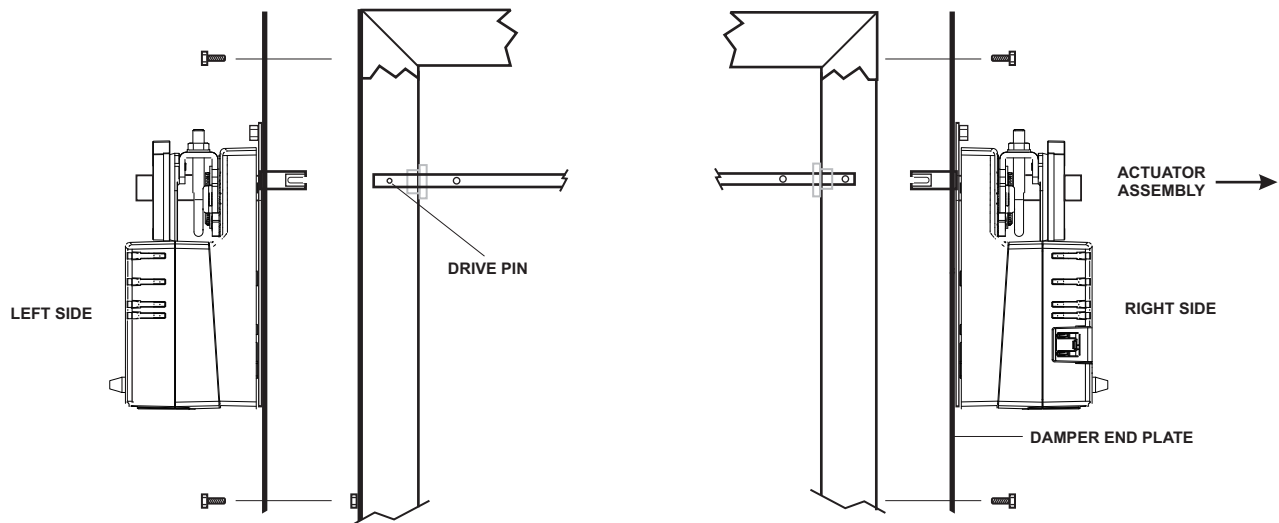

OPTIONAL BAROMETRIC BLADE LOCKING FEATURE

Some applications may require that the barometric blade feature be locked in place for conventional damper operation.

1. Locking the barometric blade should be done prior to installing the damper in the duct.
2. With the damper in the closed position, loosen the bracket holding the shaft adaptor on the actuator.
3. Pull the shaft adaptor out and rotate it until the drive slot lines up with the damper shaft drive pin.
4. Push the drive slot over the pin and re-tighten the shaft adaptor to the actuator.

