

Honeywell

TC300 Commercial Thermostats

CONNECTED DEVICE FOR COMMERCIAL BUILDINGS

CONFIGURATION AND USER GUIDE



TABLE OF CONTENTS

Declaration	6
Waste Electrical and Electronic Equipment (WEEE)	6
FCC Part 15 compliant	6
Regulation (EC) No 1907/2006	6
Important Safety Information and Installation Precautions.....	7
Introduction.....	9
About TC300 Thermostats	10
Features	10
Intended audience and assumed knowledge.....	11
Reference documents	11
Abbreviation and nomenclature	12
Dimensions	12
Technical specifications.....	14
Terminal layout TC30XB / TC32XB (24 VAC).....	21
Terminal layout TC30XC / TC32XC	22
Terminal assignment 24 VAC (TC30XB / TC32XB).....	24
Terminal assignment Line Voltage (TC30XC / TC32XC).....	26
Security requirement.....	27
Overview.....	28
Home screen: Temperature reading and adjustment.....	29
Quick access screen (right side screen): Device configuration.....	30
Ambiance screen (left side screen): Sensor reading	31
Home screen icon overview.....	31
Inactive display modes	33
Display timeout properties	34

Getting Started	35
Prerequisites	36
Guided set-up	37
Configuration	47
Configuration screen	49
Basic configuration	50
Equipment configuration	61
Coil Freeze Protection	81
Entry Door Switch and Balcony/Window Sensor Configuration	84
I/O terminal assignment.....	86
Sensors	89
Discharge air control	95
Dehumidification	97
Valve cycle.....	98
Advanced configuration	99
Setpoint options - All equipment types.....	100
Heat pump	102
Cooling options - For Heat pump & Conventional equipment	104
Cooling options - For Fan coil equipment.....	106
Heating options - For Heat Pump and Conventional equipment.....	108
Heating options - For Fan coil equipment.....	110
Pipe sensor thresholds	112
Valve purge	113
Compressor delay time	114
Miscellaneous	114
Service mode.....	115
Standby action	118
Security log	119
Diagnostics	120
Connection	121
Mobile App Connection	134
Integrating with occupant app and cloud registration	138
User management	142
User roles.....	143

Home screen (Display management)146

Display settings.....148

Reset to default150

System status.....151

Setpoints.....153

System mode.....155

Fan speed.....156

Auto firmware update157

Sylk Device support TR100 as TR75.....158

TC300 Support Wall Module “TR100 Using TR75 Emulation”
on Sylk Addr.6 Limitations159

Auto Demand Response163

Alarms.....164

 Alarms164

 Alarm notification signs.....164

 Alarm notification.....165

 Alarm preference166

 Unacknowledged alarms.....170

 List of alarms and their severity173

 Managing the alarms.....174

Scheduling.....182

 About schedule.....182

 Commercial schedule183

 Holiday schedule188

 Special event194

 Residential Schedule197

 Vacation Mode.....202

 Fixed Setpoints.....205

 Hospitality207

Declaration

This document contains Honeywell proprietary information. Information contained herein is to be used solely for the purpose submitted, and no part of this document or its contents shall be reproduced, published, or disclosed to a third party without the express permission of Honeywell International Inc.

While this information is presented in good faith and believed to be accurate, Honeywell disclaims the implied warranties of merchantability and fitness for a purpose and makes no express warranties except as may be stated in its written agreement with and for its customer.

In no event is Honeywell liable to anyone for any direct, special, or consequential damages. The information and specifications in this document are subject to change without notice.

Copyright 2025 – Honeywell International Inc.

Waste Electrical and Electronic Equipment (WEEE)

WEEE: Waste Electrical and Electronic Equipment Directive	
	<ul style="list-style-type: none"> • At the end of the product life, dispose of the packaging and product in an appropriate recycling center. • Do not dispose of the device with the usual domestic refuse. • Do not burn the device.

FCC Part 15 compliant

This device complies with part 15 of the FCC Rules. Operation is subject to the following two conditions:

- (1) This device may not cause harmful interference, and
- (2) This device must accept any interference received, including interference that may cause undesired operation.

Regulation (EC) No 1907/2006

According to Article 33 of Reach Regulation, be informed that the substances listed below may be contained in these products above the threshold level of 0.1% by weight of the listed article.

Product/Part Code	Substance Name	CAS Number
Only TC300 thermostats main board PCBA	Lead	7439-92-1
	Lead oxide	1317-36-8

Important Safety Information and Installation Precautions

Read all instructions

Failure to follow all instructions may result in equipment damage or a hazardous condition. Read all instructions carefully before installing equipment.

When performing any work (installation, mounting, start-up), all manufacturer instructions and in particular the Mounting Instructions (31-00642) are to be observed.

- TC300 Thermostats be installed and mounted only by authorized and trained personnel.
- It is recommended that devices be kept at room temperature for at least 24 hours before applying power. This is to allow any condensation resulting from low shipping/storage temperatures to evaporate.
- Do not open TC300 Thermostats, as they contain no user-serviceable parts inside!
- Investigated according to United States Standard UL- 60730-1, and UL60730-2-9.
- For TC300B/TC320B models, CE declarations according to EMC Directive 2014/30/EU.
- For TC300C/TC320C models, CE declarations according to RED Directive 2014/53/EU.
- Product standards are EN 60730-1 and EN 60730-2-9.
- TC300 Thermostats are Class B digital apparatus and complies with Canadian ICES-003.

Local codes and practices

Always install equipment in accordance with the National Electric Code and in a manner acceptable to the local authority having jurisdiction.



Electrostatic sensitivity

This product and its components may be susceptible to electrostatic discharge (ESD). Use appropriate ESD grounding techniques while handling the product. When possible, always handle the product by its non-electrical components.

High voltage safety test

Experienced electricians, at first contact, always assume that hazardous voltages may exist in any wiring system. A safety check using a known, reliable voltage measurement or detection device should be made immediately before starting work and when work resumes.

Lightning and high-voltage danger



Most electrical injuries involving low-voltage wiring result from sudden, unexpected high voltages on normally low voltage wiring. Low-voltage wiring can carry hazardous high voltages under unsafe conditions. Never install or connect wiring or equipment during electrical storms. Improperly protected wiring can carry a fatal lightning surge for many miles. All outdoor wiring must be equipped with properly grounded and listed signal circuit protectors, which must be installed in compliance with local, applicable codes. Never install wiring or equipment while standing in water.

Wiring and equipment separations



All wiring and controllers must be installed to minimize the possibility of accidental contact with other potentially hazardous and disruptive power and lighting wiring. Never place 24VAC or communications wiring near other bare power wires, lightning rods, antennas, transformers, or steam or hot water pipes. Never place wire in any conduit, box, channel, duct or other enclosure containing power or lighting circuits of any type. Always provide adequate separation of communications wiring and other electrical wiring according to code. Keep wiring and controllers at least six feet from large inductive loads (power distribution panels, lighting ballasts, motors, etc.). Failure to follow these guidelines can introduce electrical interference and cause the system to operate erratically.



Warning

By using this Honeywell literature, you agree that Honeywell will have no liability for any damages arising out of your use, or modification to, the literature. You will defend and indemnify Honeywell, its affiliates and subsidiaries, from and against any liability, cost, or damages, including attorneys' fees, arising out of, or resulting from, any modification to the literature by you.

The material in this document is for information purposes only. The content and the product it describes are subject to change without notice. Honeywell makes no representations or warranties with respect to this document. In no event shall Honeywell be liable for technical or editorial omissions or mistakes in this document, nor shall it be liable for any damages, direct or incidental, arising out of or related to the use of this document. No part of this document may be reproduced in any form or by any means without prior written permission from Honeywell.

Safety Information as per EN60730-1

TC300 Thermostats are intended for commercial environments.

TC300 Thermostats are an independently mounted electronic control system with fixed wiring.

TC300 Thermostats are used for the purpose of building HVAC control and is suitable for use only in non-safety controls for installation on or in appliances.

Introduction

This chapter contains brief description of the TC300 thermostats and their's hardware specifications.

Related topics

[About TC300 Thermostats](#)

[Features](#)

[Intended audience and assumed knowledge](#)

[Reference documents](#)

[Abbreviation and nomenclature](#)

[Dimensions](#)

[Technical specifications](#)

[Terminal layout TC30XB / TC32XB \(24 VAC\)](#)

[Terminal layout TC30XC / TC32XC](#)

[Terminal assignment 24 VAC \(TC300B/TC320B\)](#)

[Terminal assignment 24 VAC \(TC30XB / TC32XB\)](#)

About TC300 Thermostats

TC300 thermostat models are advanced, highly configurable devices providing building automation connectivity well-suited for commercial building applications. Supported equipment types include 2/4-Pipe FCU, 1H/1C, 2H, 2C conventional, and 2H/1C heat pump plus water source heat pump.

There are 12 thermostat models available

TC300B-G, TC303B-G, TC322B-G, TC300C-G1, TC303C-G, TC322C-G, TC320B-G, TC321B-G, TC323B-G, TC320C-G1, TC321C-G and TC323C-G.

The TC30x models support BACnet MS/TP and Modbus communications, while the TC32x models also support BACnet IP via Wi-Fi. All models have intelligent control algorithms, scheduling, and an intuitive touchscreen interface. The B models support low voltage power input, while the C models support line voltage power input. The TC32x models also has Wi-Fi and Bluetooth connectivity. The TC3x1 models have onboard-CO2 sensor, TC3x2 models have onboard-occupancy sensor and onboard-light sensor, TC3x3 models have onboard-CO2, onboard- occupancy and onboard-light sensor.

Features

Convenient for users

- Color, capacitive-touch screen display for intuitive, fast commissioning and exceptional user experience.
- Embedded system monitoring screen for equipment and I/O status.
- Customizable inactive display modes, Auto dim display, always on, or dark mode.
- An LED ring indicator to show the operational status.
- Real-Time Clock time-keeping accuracy with 72-hour retention during power loss.

Easy for contractors

- Fan coil, Supported equipment types include 2/4-Pipe FCU, 1H/1C, 2H, 2C conventional, and 2H/1C heat pump plus water source heat pump. (with water valve enable/lock-out) On/Off Valve, Floating Valve, Modulating Valve, and 6-Way Modulating Valve.
- 1-3 or variable speed fan
- Dehumidification with and without reheat.
- Enhanced 2-pipe fan coil functionality during seasonal or system changeover delivering improved occupant comfort.
- Service mode for manually enabling outputs for quicker diagnostics and equipment testing.
- Auxiliary heating options supporting peripheral or supplemental types.
- Auto mode to switch between heating and cooling according to the current space temperature.
- Staging control, PID Tuning, DAT Lockout, Modulating control, Compressor time delay.
- System Switch and Ventilation options.
- Integration with various external wired sensor types including Discharge air temperature, Drain pan, Occupancy, Proof of airflow, Proof of water flow, Space temperature, Outdoor air temperature, Humidity, Shutdown sensor, and 3 custom sensors.
- Complies with ASHRAE guideline 36-2021, Section 5.22 sequence of operations for high-performance operation when using floating/modulating valves and multi-speed/variable speed fan.

- Advanced commercial control algorithms such as auto changeover.

Connected for facility managers

- Thermostat can be configured via its own LCD human-machine interface (HMI) or a BACnet/Modbus client.
- Multiple, configurable user types with customizable privileges to prevent unauthorized usage.
- Customizable daily schedules include options for setting up to 10 recurring holidays (with support for floating holidays) and up to 10 specific special events.
- Up to 4 schedule events per day.

Intended audience and assumed knowledge

This document provides information about installing and commissioning a TC300 Thermostats. It also shows how to operate the user interface.

It is assumed that the user is trained and familiar with HVAC concepts.

IMPORTANT: Always install equipment in accordance with the National Electric Code and in a manner acceptable to the local authority having jurisdiction (AHJ). No guidelines, instructions, installation practices, or other information presented in this guide may be interpreted to supersede or modify the local codes and practices of the AHJ.

Reference documents

- TC300 Commercial Thermostats Datasheet (31-00645)
- TC300 Commercial Thermostats Mounting & Installation instructions (31-00642)
- TC300 Commercial Thermostats Pocket guide (31-00648)
- TC300 Deco Plate Pocket guide (31-00657)
- TC300 BACnet Integration guide (31-00646)
- TC300 Modbus Integration guide (31-00670)

Abbreviation and nomenclature

Abbreviation	Definition
AHU	Air Handling Unit
VAC	Volts AC (Alternating Current)
VDC/ DC	Volts DC (Direct Current)
BMS	Building Management System
HMI	Human Machine Interface
DAT	Discharge Air Temperature
OAT	Outdoor Air Temperature

Dimensions

Thermostat

Figure 1 Dimensions

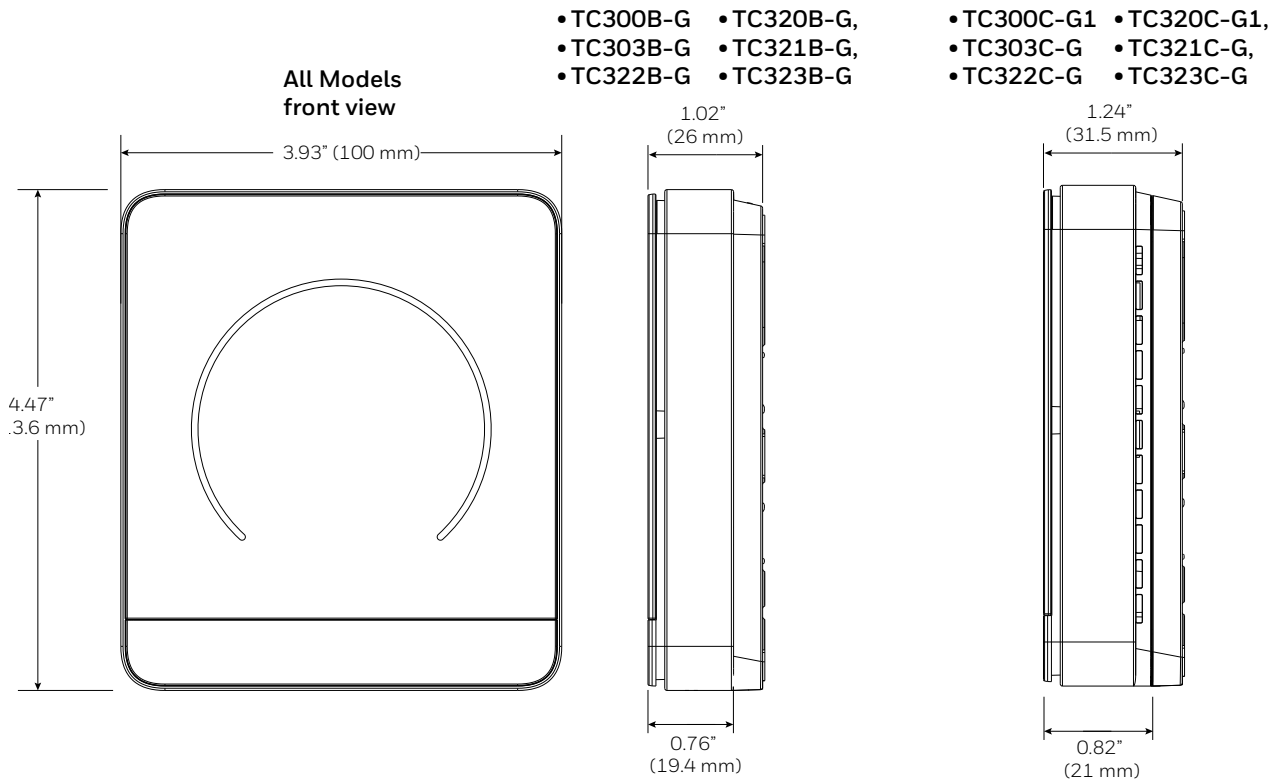

TRTC-DECOPLATE-1

Figure 2 Decoplate Dimensions

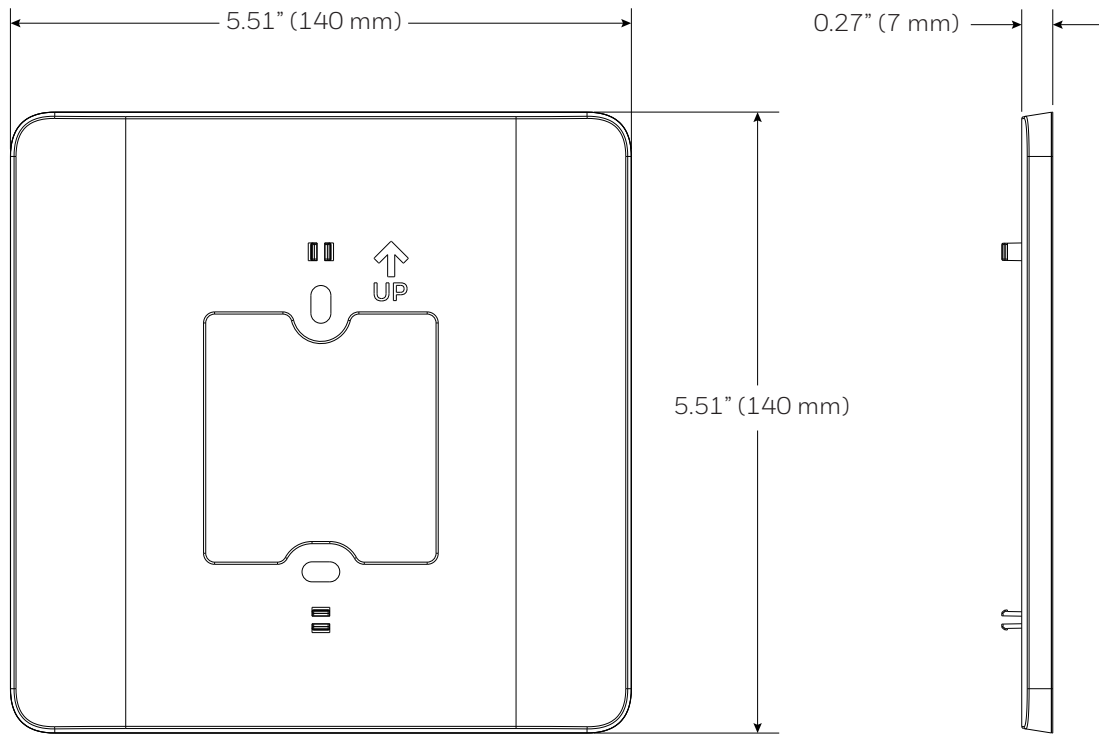

Technical specifications

Electrical Characteristics

Table 1: Power Characteristics

Parameter	TC300B-G TC320B-G TC303B-G TC321B-G TC322B-G	TC300C-G1 TC320C-G1 TC303C-G TC321C-G TC322C-G	TC300C-G TC320C-G
Power Supply	Rated voltage: 24 VAC 50/60 Hz Working Voltage range: 20-30 VAC UL listed class - 2 transformer or IEC 61558 listed transformer	Rated voltage: 100-240 VAC 50/60 Hz	Rated voltage : 100-277 VAC 50/60 Hz
Standby Power Consumption (Display On)	1.5 VA@24 VAC	3.3 VA@Rated voltage	3.3 VA@Rated voltage
Max. Load	96 VA (all DOs ON)	1200 VA@120 VAC 1500 VA@240/277 VAC (all DOs ON)	1200 VA@120 VAC 1500 VA@240/277 VAC (all DOs ON)
Rated Impulse Voltage	500 V	4kV (Overvoltage Category III)	2.5 KV (Overvoltage Category II)
Pollution Degree	2		
Operation Method	Type 1.B Action		
DO/DIO Combined Max. Current Limit	Total current cannot exceed 4 A	Total current cannot exceed 10 A	Total current cannot exceed 10 A

User Interface

Table 2: User Interface

Parameter	Specifications
Display Type	Capacitive touch TFT, 320x240 pixels, 2.4 in. diag.
Backlight	LCD (Dimmable)
LED Color Ring	Blue (cooling) Orange (heating)

Operating Environment

Table 3: Operating Environment

Parameter	Specifications
Ambient Operating Temperature	Range: 32 to 122 °F (0 to 50 °C)
Ambient Operating Humidity	10 to 90 % relative humidity (non-condensing)
Storage Temperature	-40 to 150 °F(-40 to 65.5 °C)
Protection Class	IP20

Compliances

Table 4: Compliances

SKU	TC300B-G	TC320B-G	TC300C-G	TC320C-G
Certificates	CE, FCC, ICES, UL/cUL, RoHS, REACH, Prop65		CE, FCC, ICES, RoHS, REACH, Prop65	
Standards	EN 60730-1 EN 60730-2-9 UL60730-1 UL60730-2-9 Title 47 part 15 subpart B ICES-003	EN 60730-1 EN 60730-2-9 UL60730-1 UL60730-2-9 Title 47 part 15 subpart B Title47 part15 subpart C ICES-003 RSS247 EN 300 328 EN 301 489-1 EN 301 489-17 EN 62479 EN 62311	EN 60730-1 EN 60730-2-9 Title 47 part 15 subpart B ICES-003	EN 60730-1 EN 60730-2-9 Title 47 part 15 subpart B Title47 part15 subpart C ICES-003 RSS247 EN 300 328 EN 301 489-1 EN 301 489-17 EN 62479 EN 62311

IO Characteristics

Table 5: IO Characteristics

Parameter		Specifications
All models	UIO x 3	<ul style="list-style-type: none"> • Resistive Temperature Sensor Input <ul style="list-style-type: none"> – NTC10K Type II, C7021 series – NTC10K Type III, C7023 series – NTC20K, TR21, and C7041 series • Digital Input <ul style="list-style-type: none"> – Dry contact closure – Open circuit (100 Kohms) – Closed circuit (100 ohms) • Voltage Output <ul style="list-style-type: none"> – 0-10 V, ± 1.5 % of full scale @2 Kohms
TC300B TC320B-G TC303B-G TC321B-G TC322B-G	DIO x 2	<ul style="list-style-type: none"> • Resistive Temperature Sensor Input <ul style="list-style-type: none"> – NTC10K Type II, C7021 series – NTC10K Type III, C7023 series – NTC20K, TR21, and C7041 series • Digital Input <ul style="list-style-type: none"> – Dry contact closure – Open circuit (100 Kohms) – Closed circuit (100ohms)
	DO x 3 DIO x 2	<ul style="list-style-type: none"> • Relay Output • Rated Average Current <ul style="list-style-type: none"> – 1 A Resistive at 24 VAC • Rated Pulse Current <ul style="list-style-type: none"> – 3.5 A Resistive at 24 VAC
TC300C-G TC320C-G	DO1 DO2	<ul style="list-style-type: none"> • Relay Output • Rated Average Current <ul style="list-style-type: none"> – 1 A Inductive at 100-277 VAC • Power Factor > 0.85
	DO3 DO4 DO5	<ul style="list-style-type: none"> • Relay Output • Rated Average Current <ul style="list-style-type: none"> – 3 A Inductive at 100-277 VAC • Power Factor > 0.85
TC300C-G1 TC320C-G1 TC303C-G TC321C-G TC322C-G	DO1 DO2	<ul style="list-style-type: none"> • 1 A Inductive at 120-277 VAC
	DO3 DO4 DO5	<ul style="list-style-type: none"> • 1/4 HP Motor Load @ 120VAC, 240VAC • 277 VAC, 3A, General Use

Onboard Sensors

Table 6: Onboard Sensors

Temperature Accuracy	<p>TC300B-G / TC303B-G / TC321B-G / TC322B-G: ± 1.5 °F (0.8 °C) from 32 to 122 °F (0 to 50 °C) ± 0.8 °F (0.45 °C) with 95 % confidence from 60 to 85 °F (15 to 30 °C)</p> <p>TC320B-G / TC300C-G TC320C-G TC300C-G1 / TC320C-G1 / TC303C-G / TC321C-G / TC322C-G ± 1.5 °F (0.8 °C) from 32 to 122 °F (0 to 50 °C) ± 0.9 °F (0.5 °C) with 95 % confidence from 60 to 85 °F (15 to 30 °C)</p>
Temperature Control Accuracy	± 1.5 °F (0.8 °C) from 60 to 85 °F (15 to 30 °C), all models.
Temperature Display Precision	1 °F (0.5 °C), all models
Humidity Accuracy	<p>TC300B-G / TC300C-G TC320C-G TC300C-G1 / TC320C-G1 / TC303C-G / TC321C-G / TC322C-G ± 3 % RH from 20 to 80 % RH @ 25 °C</p> <p>TC320B-G / TC303B-G / TC321B-G / TC322B-G ± 5 % RH from 20 to 80 %RH @ 25 °C</p>
Humidity Display Precision	1 % RH, all models.
Humidity Display Precision	1 % RH, all models.
CO2 Accuracy	TC321C-G / TC303C-G / TC321B-G and TC303B-G ± 30 ppm $\pm 3\%$ of reading between 400 ppm and 5000 ppm
CO2 output resolution:	1 ppm
Occupancy Sensor	<p>TC303C-G / TC322C-G / TC303B-G / TC322B-G 61 GHz to 61.5 GHz Doppler Radar Maximum 120 degrees horizontal plane field of sensing and max 8m sensing distance at center and 6m at maximum sensing angle.</p>

Wired and Wireless Technologies

Table 7: Wired and Wireless Technologies

Sylk™	Honeywell Sylk™, 2-wire Bus
BACnet MS/TP	RS485 (9.6, 19.2, 38.4, 76.8, 115.2 Kbps)
Modbus RTU	RS485 (1.2 to 115.2 Kbps)
BACnet IP (TC320B/TC320C)	Over Wi-Fi
Wi-Fi 2.4GHz (TC320B/TC320C)	IEEE802.11 b/g/n NONE, WPA_PSK, WPA_WPA2_PSK, WPA2_PSK, WPA2_WAP3_PSK, WPA3_PSK
Bluetooth (TC320B/TC320C)	BLE 5.3 Class 2 IEEE802.15.4 Open Thread

EIRP Information

Table 8: EIRP information

Standard	Max. EIRP
Wi-Fi 2.4 GHz for CE	20 dBm
BLE for CE	10 dBm

Supported Sensors and Functions

Table 9: Supported Sensors

Sensors	Options	Part Numbers
Occupancy Sensor	Direct (Normally Open) Reverse (Normally Closed)	Dry contact occupancy sensor
Proof Of Air Flow Sensor	Direct (Normally Open) Reverse (Normally Closed)	DPS200 DPS400 DPS1000 MCS, CS, CSP current switches (Dry contact switches)
Discharge Air Temperature Sensor	NTC 20K NTC 10K Type II NTC 10K Type III Sylk	C7250A C7041 C7021 C7023 C7400S

Table 9: Supported Sensors

Sensors	Options	Part Numbers
Space Temperature Sensors	NTC 20K NTC 10K Type II NTC 10K Type III Sylk	TR21 C7041, C7772A, C7021, C7772F, C7023, C7772G, TR40, TR40-H, TR40-CO2, TR40-H-CO2, TR50-3N, TR50-3D
Pipe Sensor	NTC 20K NTC 10K Type II NTC 10K Type III	C7250A C7041 C7021 C7023
Changeover Switch	Closed with heat Closed with cool	Digital input
Drain Pan / Leak Detector	Direct (Normally Open) Reverse (Normally Closed)	Dry contact float switch or water sensor
Proof of Water Flow Sensor	Direct (Normally Open) Reverse (Normally Closed)	Dry contact pressure switch
Shutdown sensor	Direct (Normally Open) Reverse (Normally Closed)	Digital input
Custom sensor (remote monitoring)	Digital Input - NO or NC Analog Input - 0-10VDC - 0-100% scaled Temperature Input - NTC 20K, NTC 10K Type II, and Type III	Digital input Analog input

TC300 Models

Table 10: TC300 Models

SKU	Input Power	Wireless	Wired Communications	Equipment types	Outputs
TC300B-G	24 VAC	No	RS485 BACnet MS/TP Modbus RTU	FCU - 4 Pipe/2 Pipe 2H/1C Heat Pump (air/water source) 1H/1C Conventional	3 x DO (24 VAC) 2 x DIO 3 x UIO
TC320B-G		Wi-Fi/BACnet IP, Bluetooth			
TC300C-G	100-277 VAC	No		FCU - 4 Pipe/2 Pipe	5 x DO (100-277 VAC) 3 x UIO
TC320C-G		Wi-Fi/BACnet IP, Bluetooth			

Accessory

Table 11: Accessory

TRTC-DECOPLATE-1	Decorative wall plate, TR and TC Series
------------------	---

For more details please refer to TC300 Thermostat Mounting Instructions - 31-00642.

Terminal layout TC30XB / TC32XB (24 VAC)

Figure 3 Terminal layout TC300B/TC320B (24 VAC)

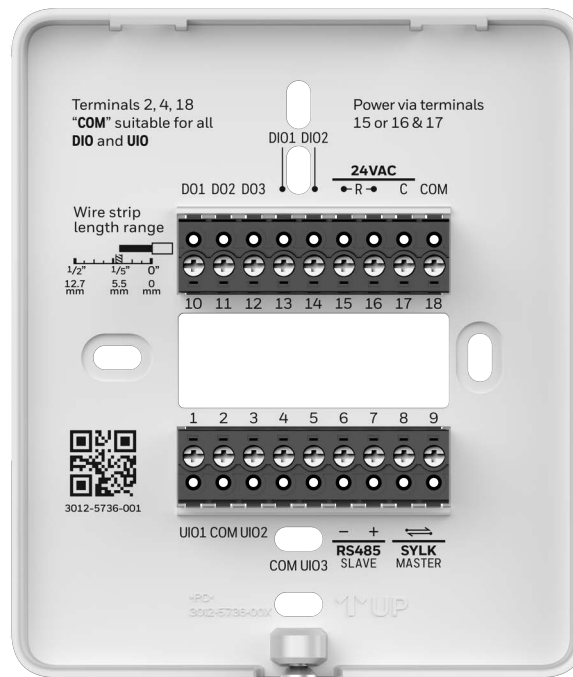

Table 12: Terminal Identification TC30XB / TC32XB (24 VAC)

Terminal Name	Terminal Number	Terminal Label	Description
UIO1	1	UIO1	Universal input/output
COM	2	COM	Common
UIO2	3	UIO2	Universal input/output
COM	4	COM	Common
UIO3	5	UIO3	Universal input/output
RS485 SLAVE	6	-	BACnet/Modbus Communications
RS485 SLAVE	7	+	BACnet/Modbus Communications
SYLK MASTER	8	↔	Sylk bus
SYLK MASTER	9	↔	Sylk bus
DO1	10	DO1	Relay output
DO2	11	DO2	Relay output
DO3	12	DO3	Relay output
DIO1	13	DIO1	Relay output Analog input Dry contact digital input
DIO2	14	DIO2	Relay output Analog input Dry contact digital input

Table 12: Terminal Identification TC30XB / TC32XB (24 VAC) (Continued)

Terminal Name	Terminal Number	Terminal Label	Description
24VAC POWER	15/16	R	24 VAC power from Class2 transformer
24VAC POWER	17	C	24 VAC common (Neutral) from Class2 transformer
COM	18	COM	Common

Terminal layout TC30XC / TC32XC

Figure 4 Terminal layout TC30XC / TC32XC

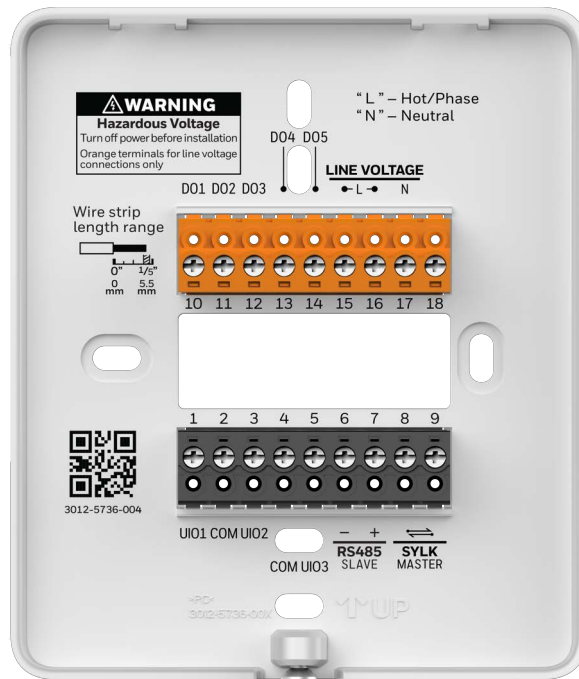

Table 13: Terminal Identification TC30XC / TC32XC

Terminal Name	Terminal Number	Terminal Label	Description
UIO1	1	UIO1	Universal input/output
COM	2	COM	Common
UIO2	3	UIO2	Universal input/output
COM	4	COM	Common
UIO3	5	UIO3	Universal input/output
RS485 SLAVE	6	-	BACnet/Modbus Communications
RS485 SLAVE	7	+	BACnet/Modbus Communications
SYLK MASTER	8	↔	Sylk bus
SYLK MASTER	9	↔	Sylk bus

Table 13: Terminal Identification TC30XC / TC32XC (Continued)

Terminal Name	Terminal Number	Terminal Label	Description
DO1	10	DO1	Relay output
DO2	11	DO2	Relay output
DO3	12	DO3	Relay output
DO4	13	DO4	Relay output
DO5	14	DO5	Relay output
Line Voltage Hot/Phase	15/16	L	Line - Line voltage power input TC300C-G/TC320C-G: 100-277 VAC
Line Voltage Neutral	17	N	Neutral - Line voltage power input
Not applicable	18	NC	Not connected

Terminal assignment 24 VAC (TC30XB / TC32XB)

Table 14: Terminal assignment 24 VAC (TC30XB / TC32XB)

Type	Terminal	Label	Terminal Assignments		
			Default	Inputs	Outputs
Digital Output	DO1	DO1	On/Off Heat	NA	Heating On/Off, Heating Floating Open, Cooling Floating Open, Valve On/Off, Valve Floating Open, Changeover Valve, Fan Command, High Speed Fan, Medium Speed Fan, Low Speed Fan, Auxiliary Heat, Heat Stage1, Cool Stage1, Humidifier, Dehumidifier, Valve Stage1, CO2 output, Occupancy output, *Lighting control output. Note: FCU changeover valve used to switch between heating and cooling modes
	DO2	DO2	On/Off Cool	NA	Heating Floating Close, Cooling Floating Close, Cooling On/Off, Valve Floating Close, Changeover Valve, Fan Command, High Speed Fan, Medium Speed Fan, Low Speed Fan, Auxiliary Heat, Heat Stage2, Cool Stage1, Cool Stage2, Reversing Valve, Dehumidifier, Humidifier, CO2 output, Occupancy output, *Lighting control output.
	DO3	DO3	NA	NA	Cooling Floating Open, Changeover Valve, Fan Command, High Speed Fan, Medium Speed Fan, Low Speed Fan, Auxiliary Heat, Heat Stage1, Cool Stage1, Water Flow Valve, Dehumidifier, Humidifier, CO2 output, Occupancy output, *Lighting control output.
	DIO1	DIO1	NA	Discharge Air Sensor, Drain Pan Sensor, Occupancy Sensor, Proof of Airflow, Pipe Sensor, Space Temp Sensor, Changeover Switch, Proof of Waterflow, Outdoor Air Sensor, Shutdown Sensor, Custom1, Custom2, Custom3 sensors, Freeze switch, Entry door switch, Balcony/Window.	Cooling Floating Close, Changeover Valve, Fan Command, High Speed Fan, Medium Speed Fan, Low Speed Fan, Auxiliary Heat, Dehumidifier, Humidifier, CO2 output, Occupancy output, *Lighting control output.
	DIO2	DIO2	NA	Discharge Air Sensor, Drain Pan Sensor, Occupancy Sensor, Proof of Airflow, Pipe Sensor, Space Temp Sensor, Changeover Switch, Proof of Waterflow, Outdoor Air Sensor, Shutdown Sensor, Custom1, Custom2, Custom3 sensors, Freeze switch, Entry door switch, Balcony/Window	Changeover Valve, Fan Command, High Speed Fan, Medium Speed Fan, Low Speed Fan, Auxiliary Heat, Dehumidifier, Humidifier, CO2 output, Occupancy output, *Lighting control output.

Table 14: Terminal assignment 24 VAC (TC30XB / TC32XB)

Type	Terminal	Label	Terminal Assignments		
			Default	Inputs	Outputs
Universal Input/ Output	UIO1	UIO1	NA	Discharge Air Sensor, Drain Pan Sensor, Occupancy Sensor, Proof of Airflow, Pipe Sensor, Space Temp Sensor, Changeover Switch, Proof of Waterflow, Outdoor Air Sensor, Shutdown Sensor, Custom1, Custom2, Custom3, Freeze switch, Entry door switch, Balcony/Window.	6-Way Valve, Modulating Cool, Modulating Heat, Modulating Valve, Variable Speed Fan, CO2 output.
	UIO2	UIO2	NA		
	UIO3	UIO3	NA		

Note: * The lighting output provides 24VAC to activate separate dry contact relay. This relay will interface with digital input on appropriate DDC lighting controller. Consult user guide or data sheet for maximum relay coil current rating.

Terminal assignment Line Voltage (TC30XC / TC32XC)

Table 15: Terminal assignment Line Voltage (TC30XC / TC32XC)

Type	Terminal	Label	Terminal Assignments		
			Default	Inputs	Outputs
Digital Output	DO1	DO1	On/Off Heat	NA	Heating On/Off, Valve On/Off, Changeover Valve, Auxiliary Heat, Heat Stage1, Valve Stage1, CO2 output, Occupancy output, *Lighting control output, Humidifier.
	DO2	DO2	On/Off Cool	NA	Cooling On/Off, Changeover Valve, Auxiliary Heat, Cool Stage1, CO2 output, Occupancy output, *Lighting control output, Humidifier.
	DO3	DO3	Low Speed Fan	NA	Changeover Valve, Low Speed Fan, Auxiliary Heat, Heat Stage1, Cool Stage1, CO2 output, Occupancy output, *Lighting control output, Humidifier.
	DO4	DO4	Medium Speed Fan	NA	Changeover Valve, Medium Speed Fan Auxiliary Heat, CO2 output, Occupancy output, *Lighting control output, Humidifier.
	DO5	DO5	High Speed Fan/Fan Command	NA	Changeover Valve, Fan Command, High Speed Fan, Auxiliary Heat, CO2 output, Occupancy output, *Lighting control output, Humidifier.
Universal Input/Output	UIO1	UIO1	NA	Discharge Air Sensor, Drain Pan Sensor, Occupancy Sensor, Pipe Sensor, Space Temp Sensor, Changeover Switch, Outdoor Air Sensor, Shutdown Sensor, Custom1, Custom2, Custom3, Freeze switch, Entry door switch, Balcony/Window.	6-Way Valve, Modulating Cool Modulating Heat, Modulating Valve, Variable Speed Fan, CO2 output.
	UIO2	UIO2	NA		
	UIO3	UIO3	NA		

Note: * The lighting output provides 24VAC to activate separate dry contact relay. This relay will interface with digital input on appropriate DDC lighting controller. Consult user guide or data sheet for maximum relay coil current rating.

Security requirement

System Environmental Considerations

An Internet firewall is required to isolate the Thermostat. Unprotected Internet connections can expose and damage the thermostat system and facility components to cyber-attacks from third parties. This may cause the thermostat to malfunction and can also be misused for illegal purposes for which the operator may then be held liable.

Deployments and Maintenance Considerations

- Always keep the local server up to date on the latest security patches via a regular system update. This applies not only to workstations or servers running on Windows, Linux, Mac, or any devices that run as part of information infrastructure or operations workstation.
- Always keep the thermostat firmware with the latest released firmware to have maximum protection by built-in security features.
- Do not use default passwords for any devices (if exists). This includes, but not limited, to all server workstations, storage servers, firewall devices, routers, and mobile devices.
- Do not use weak passwords for server administrators or operators. Different user roles (for example administrator, user, guest, etc.) shall have a different password, and the user should not share common passwords.
- In case of wireless communication, malicious wireless devices can easily scan the wireless channel and inject malicious packets or mass data flow to perform Denial-of-Service attacks. Honeywell has taken steps to prevent the TC300 Commercial Thermostats device from being injected, but the mass data flow will result in the loss of wireless communication bandwidth within the whole system. A regular check of the communication failure rate or response rate of the thermostat is helpful to discover and isolate devices being attacked and stop the physical attacks in the daily operation

Network Communication Notice

- To keep maximum integration compatibility with third-party devices and Fast-pack communications are un-encrypted as open protocol. Improper security protection may lead to data leakage, spoofing, and/or tampered by malicious devices and denial-of-service attacks.
- To keep maximum integration compatibility with legacy devices, in-room wired devices are less secure from data confidentiality and authentication thus not-recommended for a new design. It is always highly recommended to use deep mesh wireless network communication to gain maximum protection and the latest updates.
- In case of Denial-of-Service attacks, all communication channels will inevitably have a loss of bandwidth due to malicious data flow.
- Connected devices may contain legacy technology, which is less secure under modern cyber-security attacks. Honeywell strongly recommends using a secured deep mesh wireless network communication. In case of legacy technology, the user needs to be aware of the risk of being tampered with or attacked. To reduce the attack surface, the user is advised to physically secure the wired communication signals or provide necessary shield on wires, or place necessary access control on accessing such communication wires.

Overview

This chapter describes the TC300 Thermostats display, home screens, icons, and other user interfaces. For mounting the TC300 Thermostats, refer to TC300 Thermostats Mounting instructions (31-00642).

Related topics

[Home screen: Temperature reading and adjustment](#)

[Quick access screen \(right side screen\): Device configuration](#)

[Ambiance screen \(left side screen\): Sensor reading](#)

[Home screen icon overview](#)[Active display modes](#)

[Active display modes](#)

[Display timeout properties](#)

Home screen: Temperature reading and adjustment

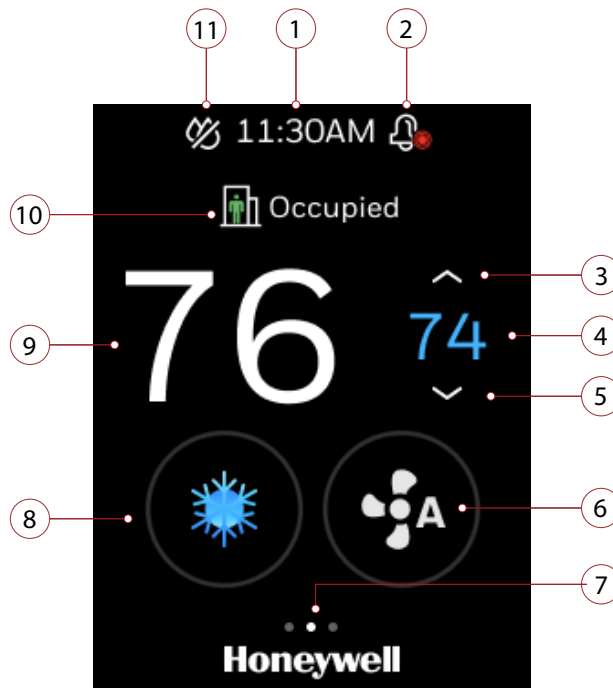

Table 16: Home screen (main screen) Overview

Item	Description
1	Time
2	Alarm status
3	Adjust temperature: Touch the up arrow to increase the desired temperature.
4	Desired temperature: Displays the desired temperature.
5	Adjust temperature: Touch the down arrow to decrease the desired temperature.
6	Fan Speed: Indicates current Fan speed for Fan Coil unit. Tap to change the fan speed.
7	Home screen indicator: Use finger to swipe to left or right to display more options.
8	System Mode Display: Orange flame for heat mode, blue snowflake for cool mode.
9	Indoor Temperature: Displays the current indoor temperature.
10	Current Schedule: Indicates the current Occupant status (Occupied, Unoccupied, Standby, Temporary)
11	Humidity: Indicates the current humidification/dehumidification status.

Quick access screen (right side screen): Device configuration

Swipe left from the home screen to view the Quick access screen.

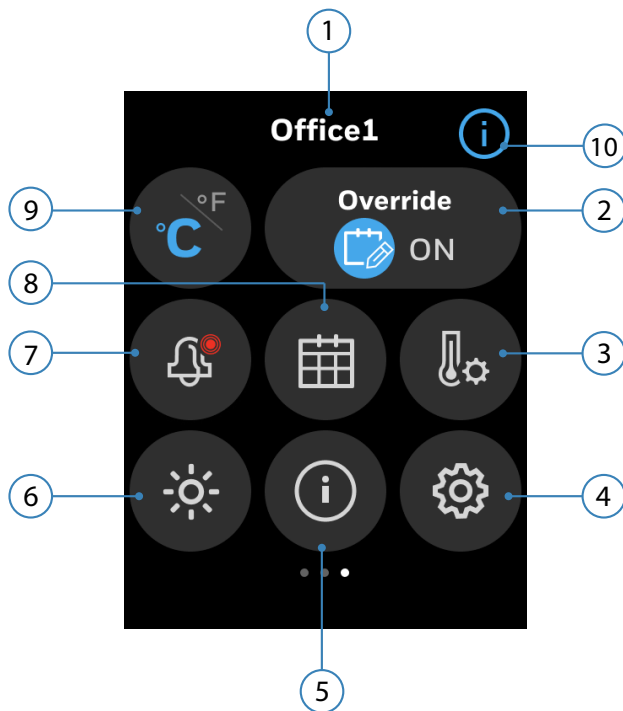

Table 17: Quick access screen

Item	Description
1	The name assigned to the thermostat.
2	Override: Override unoccupied or standby modes to allow setpoint adjustments.
3	Setpoint: Configure the set points of various parameters.
4	Config: Configure the thermostat.
5	System Status: See the system status of various equipment
6	Brightness: Adjust the display brightness and configure inactive display typ
7	Alarm: View active alarms.
8	Schedule: Set the schedules.
9	Temperature Units: Switch between Fahrenheit or Celsius.
10	Help icon: User help information for the options available on the screen.

Ambiance screen (left side screen): Sensor reading

Swipe right from the home screen to view the Ambiance screen. Establish Internet connection with thermostat, setup the location or connect to indoor sensors to display the humidity and outdoor temperature.

Figure 5 Ambiance screen (left side screen)

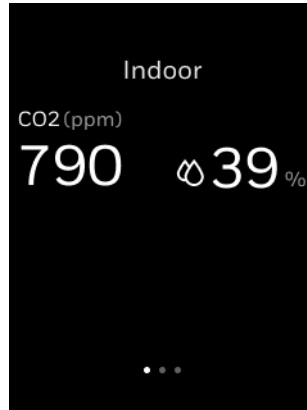

Note: The types of reading displayed varies according to the sensor connected to the thermostat.

To configure the ambiance screen, refer to [Home screen \(Display management\)](#).

Table 18: Typical ambiance screen

Description
Indoor CO2 level (ppm)
Indoor humidity%

Home screen icon overview

Table 19: Home Screen Icon Overview





Icon	Description
	High severity alarm
	Medium severity alarm
	Auto mode
	Heating mode

Table 19: Home Screen Icon Overview

















Icon	Description
	EMER heat mode
	Cooling mode
	Humidification
	Dehumidification
	Ventilation mode (Fan only)
	System off
	Fan auto
	Fan speed low
	Fan speed medium
	Fan speed high
	Fan circulate
	Fan speed variable
	WiFi signal strength
	Wi-Fi initialization failed
	Wi-Fi connection failed
	Occupied mode
	Standby mode

Table 19: Home Screen Icon Overview

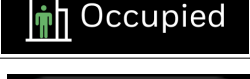

Icon	Description
 Unoccupied	Unoccupied mode
 Temporary	Temporary mode
 Permanent	Permanent mode

Figure 6 Active display modes

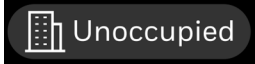

Inactive display modes

Figure 7 Inactive display modes

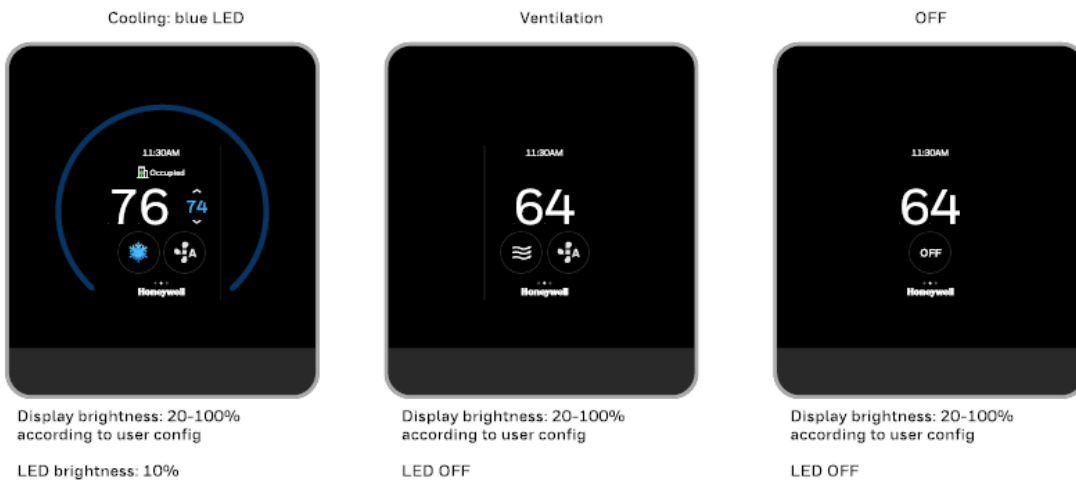
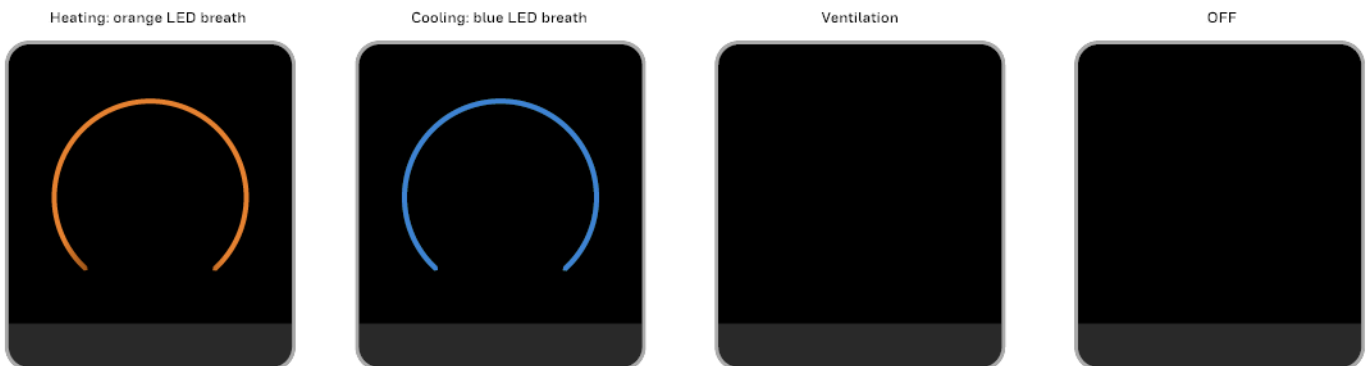

Note: To configure the ring LED and display, refer to [Display settings](#).

Display timeout properties

Table 20: Display timeout properties

LCD back light behavior	Time	Mode	LCD back light brightness (0-100, pwm)	LED back light brightness (0-100, pwm)
Wakes up when user touch the screen	Instant	Normal/Disable LCD Off/Enable dark mode	80%	10%
Dimmer when no user activity	In 10 seconds	Normal/Disable LCD Off/Enable dark mode	10%	10%
Off/black when no user activity	In 30 seconds	Normal	0%	80%
		Disable LCD off	10%	80%
		Enable dark mode	0%	0%
Return to home screen - During initial setup	In 35 seconds	-	-	-

Getting Started

This chapter contains steps and descriptions to set up the initial configuration of the thermostat and other basic configurations.

Related topics

[Prerequisites](#)

[Guided set-up](#)

Prerequisites

Before going through initial guided setup sequences, ensure the TC300 thermostats are installed and wired up according to the TC300 installation and mounting guide (31-00642).

WARNINGS

- To reduce the risk of electrical shock do not open the thermostat. There are no user-serviceable parts inside. Refer servicing to qualified service personnel only.
- Cleaning — Use a dry cloth to clean the product. Do not use liquid cleaners or aerosol cleaners
- Water and moisture — Do not use the product near water. Do not install the product in a place where water may splash onto it.
- Do not operate the thermostat with a hard, sharp, or pointed object such as a fingernail, pen.
- The screen used for the thermostat is made of glass. Therefore, it can break when the product is dropped or heavy impact is applied. Do not handle broken glass without appropriate protection in event of damage.

Guided set-up

The thermostat will be powered up automatically after it mounted on the wallplate. You will navigate through the settings given below subsequently while setting up the thermostat.

[Naming thermostat](#)

[Connecting to network](#)

[Temperature units](#)

[Date and Time](#)

[Tap the right arrow button.](#)

[System switch](#)

[Installer Passcode](#)

[Service Info](#)

To set up the thermostat

1. Power-up the thermostat.

The Honeywell logo screen appears, followed by the “Welcome to TC300” screen.

Figure 8 Welcome screens



The Welcome screen followed by the LET'S BEGIN screen appears.

Figure 9 Welcome screen

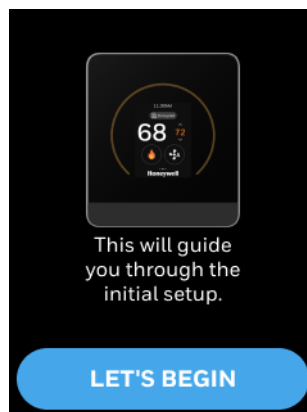

2. Changing Language Settings:
In the language settings menu, you'll see a list of available languages. The currently selected language, marked with a check-mark (e.g., English), will be displayed. Scroll through the list of languages presented:

- English
- Spanish
- French
- Italian
- German

To change the language, simply tap or click on the language option you want to select.

Figure 10 Language Settings



3. Tap next button.
The Device Name appears.

Naming thermostat

Figure 11 Device Name

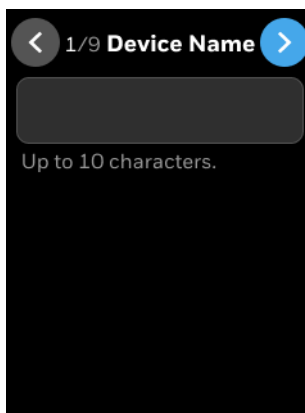

4. Tap on the text field
A keyboard will be displayed on the screen to enter the device name.

5. Enter the device name.
Assign a unique name to a thermostat specifying a name to the location where the thermostat is installed. It assists the user to easily identify the device during remote operation of the thermostat.
6. After entering a valid device name tap the right arrow button.
The device name is saved and the Connection screen appears.
Thermostat can be renamed after the initial setup completion. Refer to the [To rename the device name](#) section.

Connecting to network

Figure 12 Connection

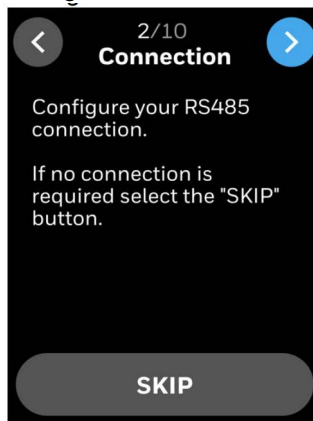

7. If no connection is required, tap **SKIP** or tap the right arrow button.
If connection is required, the connection screen appears.

Figure 13 Connection

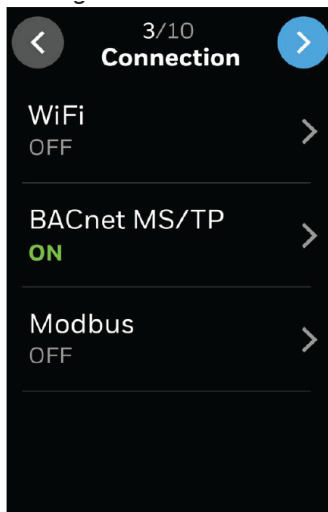

8. Tap **WiFi** and enable the BACnet IP connection. Refer to [Connection](#)
Or,
9. Tap **BACnet MS/TP** and enable the BACnet MS/TP connection. Refer to [Connection](#).
Or,
10. Tap **Modbus** and enable the Modbus connection. Refer to [Connection](#).
The General screen appears.

Temperature units

Figure 14 Temperature unit

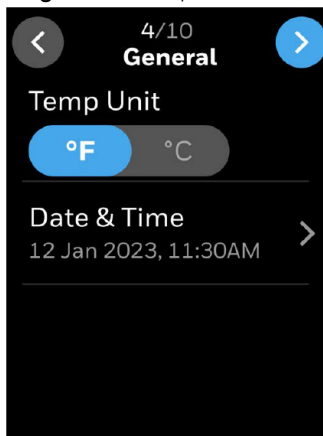

11. Select a preferred temperature unit.
12. Set the **Date & Time**. Refer to [Date and Time](#)

Equipment type

The TC300 thermostats are designed to control Conventional, Heat pump, and Fan coil units (FCU) equipment. It can control 1H/1C conventional, 2H/1C heat pump, and most 2-pipe or 4-pipe fan coil applications.

Figure 15 Equipment and I/O

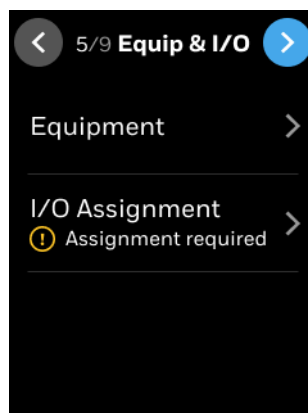

13. Tap **Equipment** and set the equipment details. Refer to [Equipment configuration](#).
14. Tap **I/O Assignment** and assign the I/Os. Refer to [I/O terminal assignment](#).
15. Tap the right arrow button.
The System Switch screen appears.

Date and Time

Figure 16 Date and Time Configuration screen

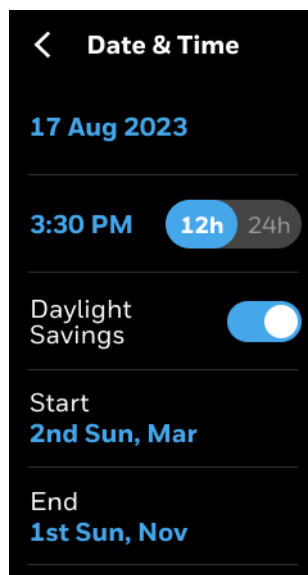

16. Tap the date to set the today's date.
17. Slide the Display toggle button to the right to set the 24h time format if required.
18. Enable **Daylight Savings** if required.
19. If Daylight saving is enabled, set the start and end date schedules for daylight savings.
20. After setting date and time, navigate back to General screen and tap the right arrow button.
The Equipment and I/O screen appears.
21. Tap the right arrow button.
The System Switch screen appears.

System switch

The operation mode of system switch depends on the equipment configuration.

Figure 17 System Switch

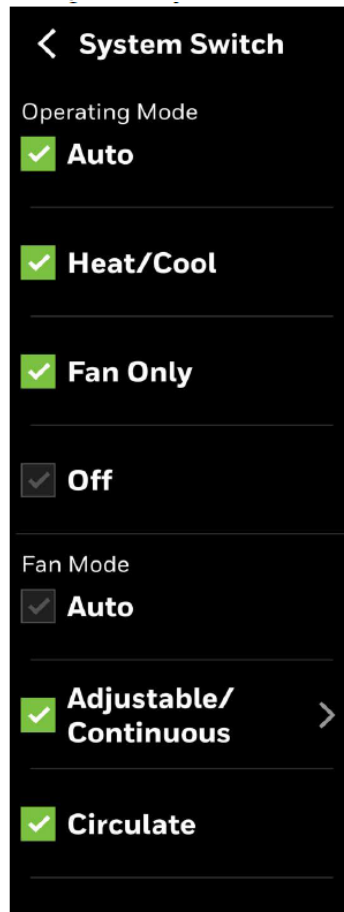

22. Set the required parameters and tap the right arrow button.
The Schedule screen appears.

Figure 18 Schedule

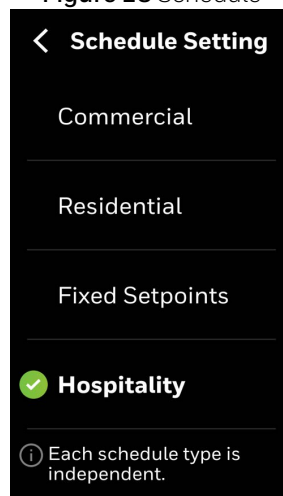

23. Once in the Schedule menu, you will see three options listed:

- Commercial
- Residential
- Fixed Setpoints
- Hospitality

Note: Each schedule type is independent. your selections for Commercial, Residential, Fixed Setpoints and Hospitality function separately from each other. Changing one will not impact the others.

24. After configuring the Schedule, tap the right arrow button on the Schedule screen to move to next screen.

The Setpoints screen appears.

In the Schedule menu, you'll see three options:

- **Occupied:**

Heating: 68°F

Cooling: 76°F

- **Standby:**

Heating: 65°F

Cooling: 80°F

- **Unoccupied:**

Heating: 55°F

Cooling: 85°F

Select the desired category (Occupied, Standby, or Unoccupied).

Adjust the heating or cooling temperatures as needed.

Figure 19 Setpoints

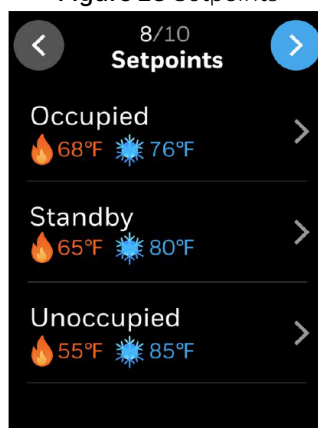

1. After configuring the Setpoints, tap the right arrow button on the Setpoints screen to move to next screen.
The Passcode screen appears.

Installer Passcode

Figure 20 Passcode

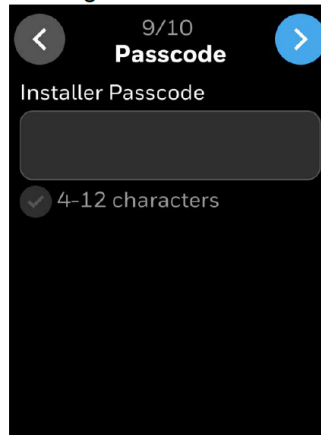

2. Tap on the text field.
A keyboard will popup.
3. Enter a passcode.
Note: The passcode must contains 4 to 12 characters including a Alpha/numeric/symbol character.
4. Tap the right arrow button.
The Service Info screen appears.
Note: The Installer passcode is to prevent unauthorized changes to thermostat settings. This passcode will be needed to enter into locked menu's, such as Advanced Configuration.

Service Info

Figure 21 Service Info

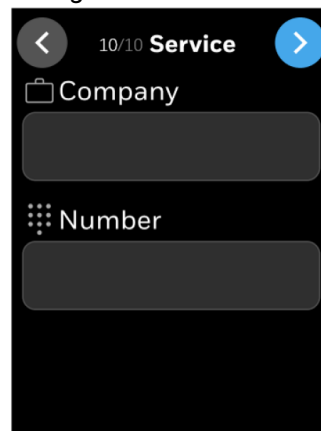

5. Enter the service personnel information.

6. Tap the right arrow button.
The Congratulations message appears.

Figure 22 Successful connection

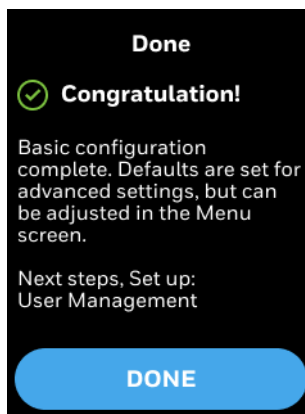

7. Tap **DONE**.
The User Management screen appears.

Figure 23 User management

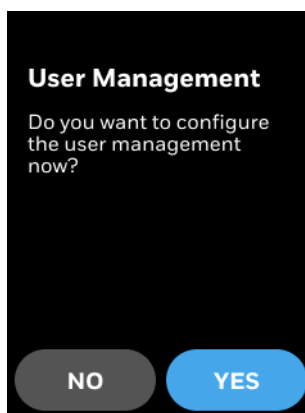

8. Tap **YES** to configure the user list. Refer to [User management](#).
9. Tap **No** to start using the thermostat.
Thermostat Home screen appears.

Figure 24 Home screen

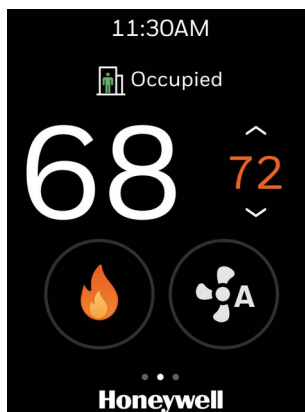

After set up the thermostat device, you can re-configure the user management equipment, schedules, alarms, and terminal assignments.

Configuration

This chapter contains thermostat level configuration and equipment level configuration procedures. Only the Installer has access to these configuration screens.

Note: *The Admin User has access to most configuration screens, with the exception of the Equipment and Advanced Configuration screens.*

Related topics

[Configuration screen](#)

[Basic configuration](#)

[Equipment configuration](#)

[I/O terminal assignment](#)

[Sensors](#)

[Discharge air control](#)

[Dehumidification](#)

[Valve cycle](#)

[Advanced configuration](#)

[Setpoint options - All equipment types](#)

[Heat pump](#)

[Cooling options - For Heat pump & Conventional equipment](#)

[Cooling options - For Fan coil equipment](#)

[Heating options - For Heat Pump and Conventional equipment](#)

[Heating options - For Fan coil equipment](#)

[Pipe sensor thresholds](#)

[Valve purge](#)

[Compressor delay time](#)

[To configure compressor delay time](#)

[Service mode](#)

[Standby action](#)

Security log

Diagnostics

Connection

Mobile App Connection

User roles

Home screen (Display management)

Display settings

Reset to default

System status

Setpoints

System mode

Fan speed

Auto firmware update

Sylk Device support TR100 as TR75

TC300 Support Wall Module "TR100 Using TR75 Emulation" on Sylk Addr.6 Limitations

Auto Demand Response

Configuration screen

The configuration screen displays all the configuration items of the thermostat and equipment.

1. Swipe left from the Home screen.
2. On the Quick access screen, tap the configuration  button.
The Configuration screen appears.

Figure 25 Configuration screen



Basic configuration

The Basic Configuration includes options to configure the thermostat setting such as Device Name, Date and Time, Screen Cleaning, Override Setting, and Service Info. You might have configured these configurations while setting up the thermostat. However, you can change the configuration here again.

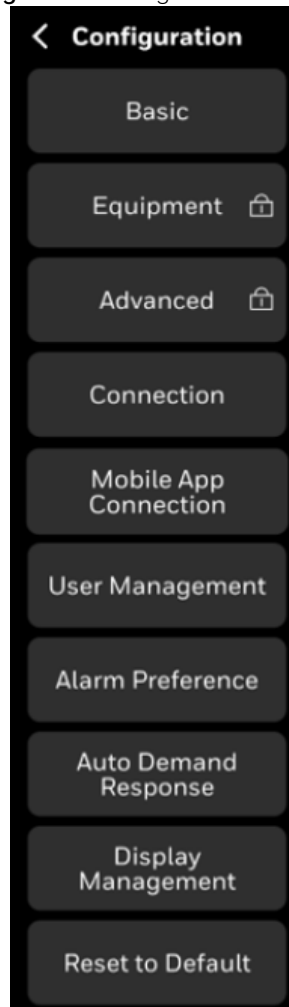
Figure 26 Basic configuration

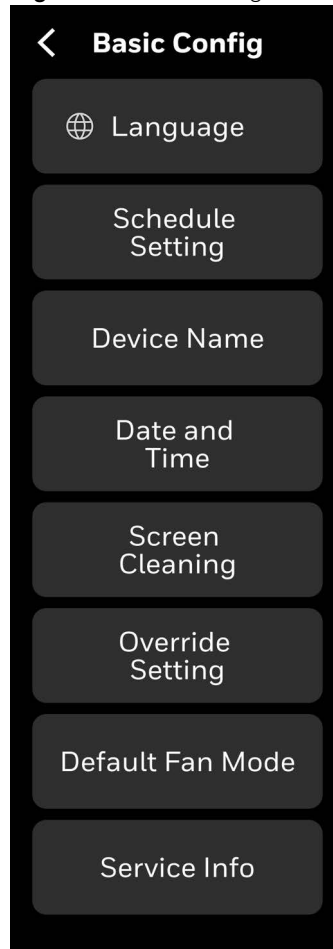

The following features are covered under the Basic configuration.

- [To configure Language Setting](#)
- [To configure system switch](#)
- [To rename the device name](#)
- [To configure Date & Time](#)
- [To enable screen cleaning mode](#)
- [To configure override setting](#)
- [To configure schedule setting](#)
- [To configure Default fan mode](#)
- [To modify service info](#)

To configure Language Setting

1. Swipe left from the Home screen.
2. On the Quick access screen, tap  > Basic > Language Setting.
The Language screen appears.

Figure 27 Language Screen



Here, the default language is English.

3. Five languages are available: English, Spanish, French, Italian, and German.
4. Select the Language from the list as desired, and click Tick button,

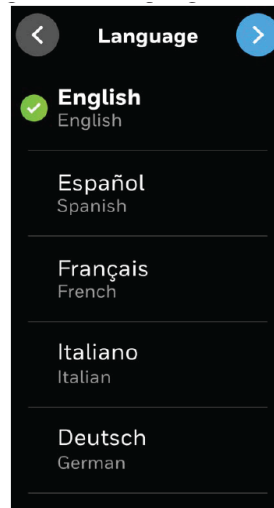
Figure 28 Language Change.

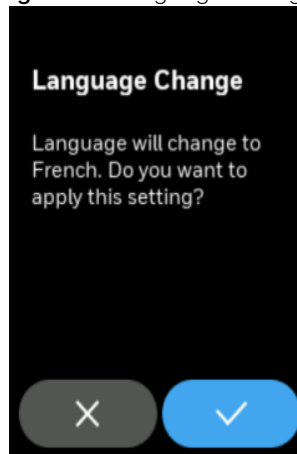

5. Tap the back button to navigate back to the previous screen and save the settings.

To configure system switch

1. Swipe left from the Home screen
2. On the Quick access screen, tap  > Equipment > System Switch. The System switch screen appears

Figure 29 System switch



Note: if the fan type is variable speed fan, can click “**Adjustable/Continuous**” to configure the switch type.

3. This will allow you to configure the switch type for your fan. You will see options for Three Speed or Variable Speed.

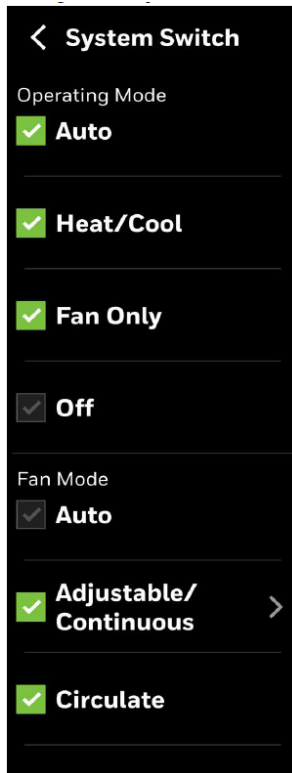
Figure 30 Variable Speed

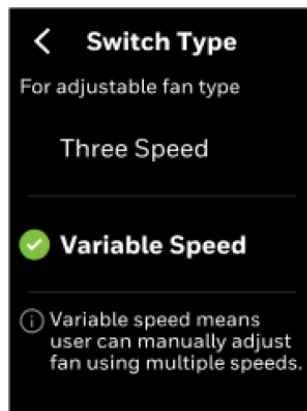

- After selecting **Variable Speed**, return to the home screen to manually set the **fan speed**. This action will display the fan speed control screen.

Figure 31 fan speed

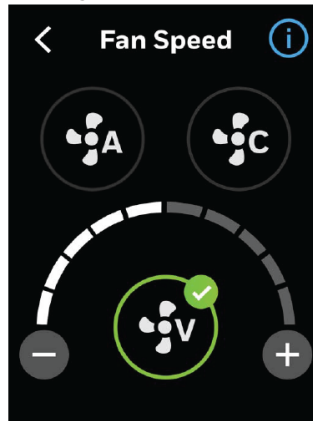

- For further assistance, you can refer to the help menu. This section provides explanations and guidelines for different operating modes such as **Circulate**, **Auto**, and **Variable**.

Figure 32 Help infor



- Select a system switch that corresponds with the HVAC equipment. Commands from the network to control the system switch mode take precedence over the setting on the TC300 thermostats. The system switch setting is saved during power outages.

To rename the device name

- Swipe left from the Home screen.
- On the Quick access screen, tap  > **Basic** > **Device Name**.
The Device name screen appears.

Figure 33 Naming the thermostat

3. Tap on the text field
A keyboard will be displayed on the screen to enter the device name.
4. Enter the device name.
Assign a unique name to a thermostat specifying a name to the location where the thermostat is installed. It assists the user to easily identify the device during remote operation of the thermostat.
5. Tap the back button to navigate back to the previous screen and save the settings.

To configure Date & Time

The date and time of the thermostat is to be set manually. You can configure the Date & time and Daylight savings.

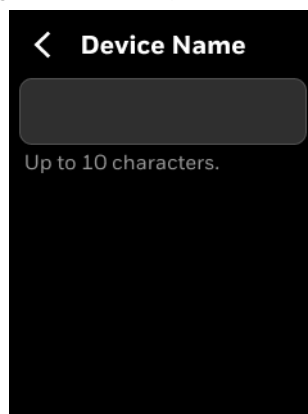
1. Swipe left from the Home screen.
2. On the Quick access screen, tap  > **Basic** > **Date and Time**.
The Date & Time screen appears.

Figure 34 Date & Time

3. Tap the date to set today's date.
4. Slide the Display toggle button to the right to set the 24h time format if required.

5. Enable **Daylight Savings** if required.
6. If Daylight savings is enabled, set the start and end date schedules for daylight savings.
7. Tap the back button to navigate back to the previous screen.

To enable screen cleaning mode

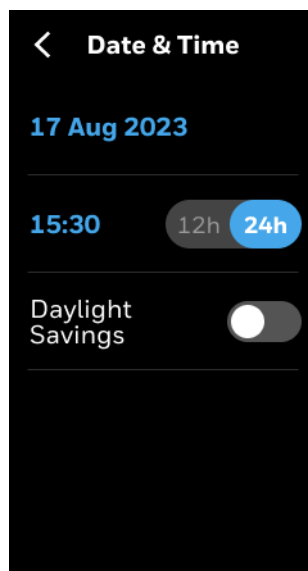
Screen cleaning mode lock/disable the touch sensitivity of the display for 30 seconds so you can clean the device display while the thermostat is functional.

1. Swipe left from the Home screen.
2. On the Quick access screen, tap  > **Basic** > scroll down > **Screen Cleaning**.
The Screen Cleaning screen appears.

Figure 35 Screen cleaning

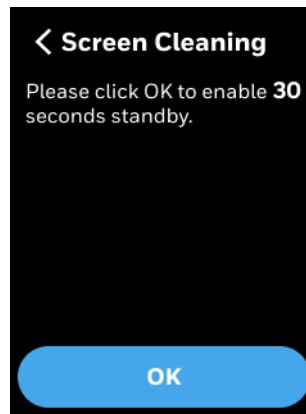

3. Tap **OK** to enable the screen cleaning mode for 30 seconds or tap the back button to navigate back to the previous screen.

To configure override setting

These settings allow users to manually adjust the system's operation mode, overriding the automatic controls. There are two types of override settings available.

Permanent Override - This setting maintains a fixed setpoint 24/7, overriding any scheduled occupied or standby periods.

Temporary Override - This allows authorized user to adjust setpoint or operating mode for a fixed interval that deviates from the standard schedule.

The override is activated when the user manually changes the setpoint on the thermostat, switching from the current mode (Occupied/Unoccupied/Standby) to a temporary mode.

1. Swipe left from the Home screen.
2. On the Quick access screen, tap  > **Basic** > scroll down > **Override Setting**.
The Override Setting screen appears.

Figure 36 Override setting



3. Tap **Temporary Override** to override the current operational mode for a given period of time. By default, overrides are set to Temporary Override. The Temporary override screen appears.

Figure 37 Temporary override

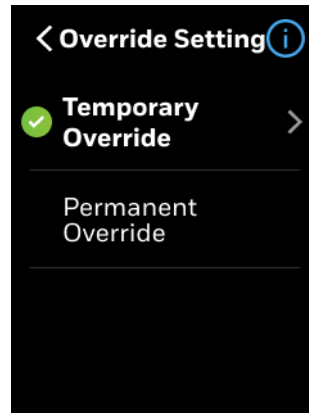
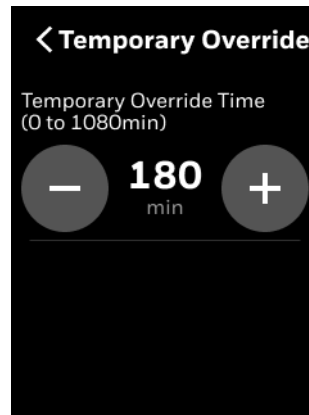

4. Set the time limit that temporary override should last. After this time, setpoint return to the scheduled mode.
5. To make the override permanent, set the override settings as Permanent override. This setting will ignore programmed schedule and thermostat will operate at fixed setpoint 24/7 adjustable by user depending on user type and profile.

To configure schedule setting

1. Swipe left from the Home screen.
2. On the Quick access screen, tap  > **Basic** > scroll down > **Schedule Setting**. The Schedule Setting screen appears.
3. Four Schedule Settings are available.
 - a. Commercial
 - b. Residential use
 - c. Fixed Setpoints
 - d. Hospitality

Figure 38 Schedule Setting



Note: Each schedule type is independent.

To configure Default fan mode

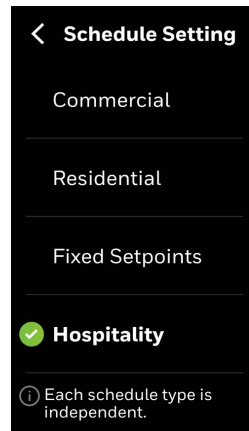
The default fan mode determines the cyclical operating mode of the fan and whether or not it is used for ventilation.

1. Swipe left from the Home screen.
2. On the Quick access screen, tap  > **Basic** > scroll down > **Default fan mode**.
The Default Fan Mode screen appears.

Figure 39 Default fan mode

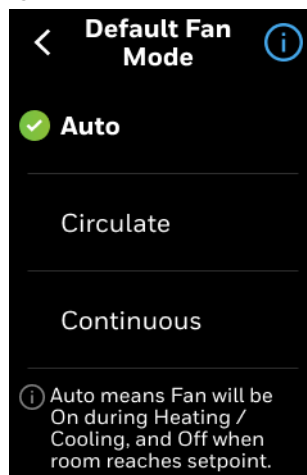

Auto - It means Fan will be On during Heating / Cooling, and Off when room reaches setpoint.

Circulate - If Circulate is available, the fan will run approximately 35% of the time, roughly 20 minutes each hour.

Continuous - It means Fan will be On in Occupied mode, and Auto in other modes. In unoccupied/standby, mode will be Auto.

Table 21: Default fan mode

Default fan mode	Fan set on home screen	Schedule status	Fan behavior
Auto	Circulate	Occupied, Standby (treat as occupied)	When there is a demand for heating or cooling, the fan will automatically activate. In the absence of such a demand, the fan will continue to operate in circulation mode to maintain air quality and comfort.
		Unoccupied, standby (treat as unoccupied)	The fan will automatically switch to Auto mode, and the fan settings cannot be adjusted from the home screen.
	Auto	Occupied, Standby (treat as occupied)	The fan will remain on when there is a demand for heating or cooling. If there is no such demand, the fan will turn off to conserve energy.
		Unoccupied, standby (treat as unoccupied)	
	Manual (Low/high)	Occupied, Standby (treat as occupied)	The fan will operate continuously based on the manual selection by the user.
		Unoccupied, standby (treat as unoccupied)	The fan will automatically switch to Auto mode, and the fan settings cannot be adjusted from the home screen.

Table 21: Default fan mode (Continued)

Default fan mode	Fan set on home screen	Schedule status	Fan behavior	
Circulate	Circulate	Occupied, Standby (treat as occupied)	When there is a demand for heating or cooling, the fan will automatically activate. In the absence of such a demand, the fan will continue to operate in circulation mode to maintain air quality and comfort.	
		Unoccupied, standby (treat as unoccupied)	The fan will automatically switch to Auto mode, and the fan settings cannot be adjusted from the home screen.	
	Auto	Occupied, Standby (treat as occupied)	When there is a demand for heating or cooling, the fan will automatically activate. In the absence of such a demand, the fan will continue to operate in circulation mode to maintain air quality and comfort.	
		Unoccupied, standby (treat as unoccupied)	The fan will remain on when there is a demand for heating or cooling. If there is no such demand, the fan will turn off to conserve energy.	
	Manual (Low/high)	Occupied, Standby (treat as occupied)	The fan should remain operational at all times, as per the user's manual selection.	
		Unoccupied, standby (treat as unoccupied)	The fan will automatically switch to Auto mode, and the fan settings cannot be adjusted from the home screen.	
	Continuous	Circulate	Occupied, Standby (treat as occupied)	Circulate button will be disabled.
			Unoccupied, standby (treat as unoccupied)	
Auto		Occupied, Standby (treat as occupied)	If there is a demand for heating or cooling, the fan will be on. If there is no such demand, the fan will remain on at the ventilation speed selected by the user.	
		Unoccupied, standby (treat as unoccupied)	If have heating/cooling demand, fan is on. If no heating/cooling demand, fan will be off.	
Manual (Low/high)		Occupied, Standby (treat as occupied)	The fan should remain operational at all times, as per the user's manual selection.	
		Unoccupied, standby (treat as unoccupied)	The fan will automatically switch to Auto mode, and the fan settings cannot be adjusted from the home screen.	

To modify service info

Service info contains the maintenance/installer/contractor personnel who provides the periodic maintenance service. To add/modify the details, follow the procedure given below.

1. Swipe left from the Home screen.
2. On the Quick access screen, tap  > **Basic** > scroll down > **Service Info**.
The Service info screen appears.

Figure 40 Service information



3. Update the name and phone number of the service personnel.
4. Tap the back button to navigate back to the previous screen and save the modified information.

Equipment configuration

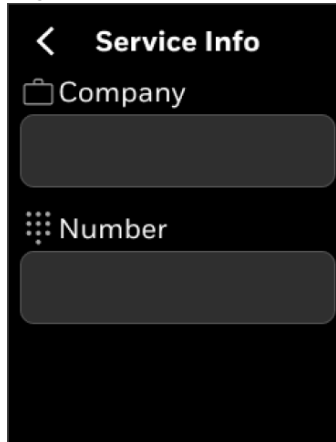
The equipment tab provides options to configure the equipment and devices connected to the thermostat. It also provides options to control advanced settings like Discharge air control, Dehumidification, Cooling, Heating, System switch, and Sylk devices settings.

Each thermostat model has different IO terminals and supports different equipment types. Refer to the [Terminal assignment 24 VAC \(TC300B/TC320B\)](#) on page 24 and [TC300 Models](#) on page 20, sections.

Configuration screen

The configuration screen displays all the configuration items of the thermostat and equipment.

1. Swipe left from the Home screen.
2. On the Quick access screen, tap the configuration  button.
The Configuration screen appears.

Figure 41 Configuration screen



To access Equipment screen

1. Swipe left from the Home screen.
2. On the Quick access screen, tap  > **Equipment**.
The Equipment screen appears.

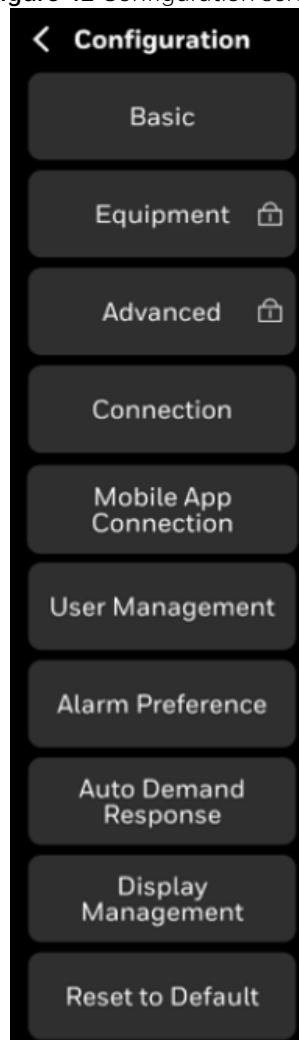
Figure 42 Equipment main menu



To configure equipment and I/O

1. Swipe left from the Home screen.
2. On the Quick access screen, tap  > **Equipment** > **Equipment & I/O**.
The Equipment screen appears.

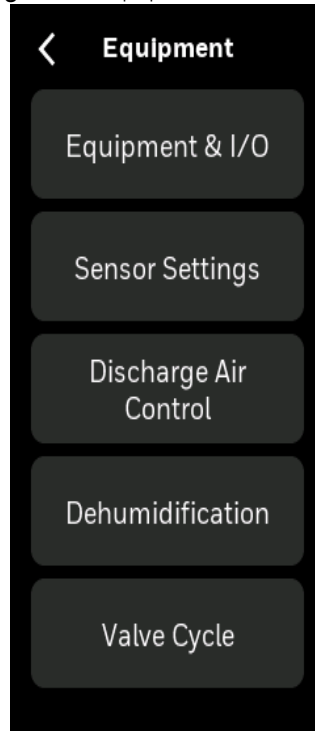
Figure 43 Equipment and I/O



3. Tap **Equipment**.

The Equipment page appears.

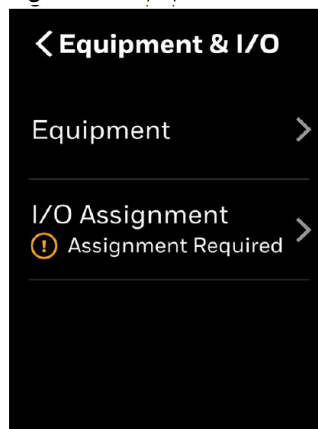
It provides options to select type of equipment such as

[Fan coil](#)

[Conventional](#)

[Heat pump](#)

Note: The equipment type and related options vary according type of TC300 thermostat models.

Figure 44 Equipment type

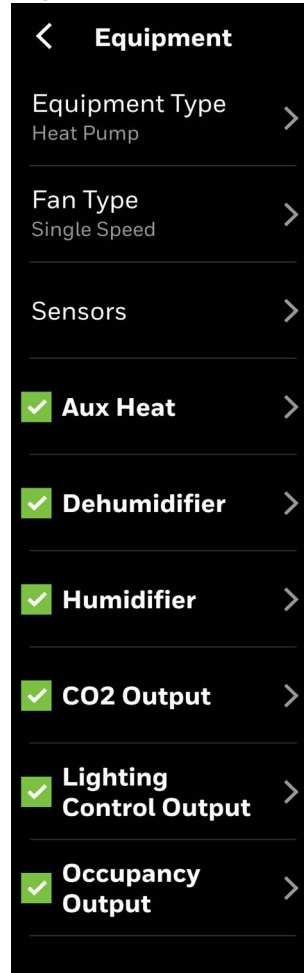

Note: The desired option may be "grayed-out" whenever there are insufficient outputs to support this function. Verify I/O is configured appropriately. So the Aux Heat, Dehumidifier, Humidifier, CO2 Output, Lighting Control Output and Occupancy Output checkboxes are available based on the equipment type selection.

CO2 Output: CO2 output can be configure as an analog output or a binary output. When configuring CO2 output, the selectivity of the configuration option should be restricted based on whether there are available terminals.

Analog output: support two types: 2-10v, 0-10v, CO2 range is from 0 to 2000 ppm. Output calculated follow this: $\text{min vol} + \text{CO2 Level} / 2000 * (\text{max vol} - \text{min vol})$. example: 1000ppm output 6V.

Figure 45 CO2 Output

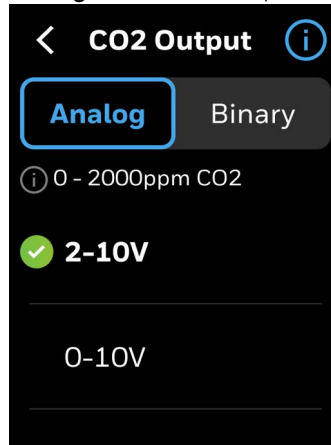

Binary output: User can configure CO2 threshold limit, (range: 500-2000ppm, default 800ppm, step 50ppm), normally open/normally closed (default normally closed).

User can configure CO2 deadband: (-100 to -300), default -100, step 50ppm.

When CO2 level is above threshold limit, will output to configured DO. When CO2 level drop down to threshold limit plus deadband, will disable output.

Alarm limit can't be less than threshold limit (Can be equal). When increase threshold limit, alarm limit will be increased.

example: Increase threshold to 1200ppm, then threshold limit will be increased to 1200ppm.

Figure 46 CO2 Output

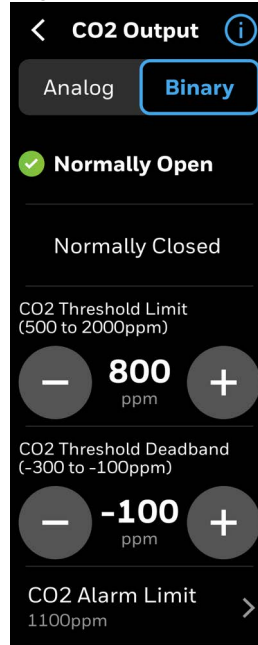

To configure fan speed setting

1. Swipe left from the Home screen
2. On the Quick access screen, tap  > Basic > Fan Speed Setting. The Fan Speed Setting screen appears.

Figure 47 Fan type



3. There are four types of fans:
 - Single Speed
 - Two Speed
 - Three Speed
 - Variable Speed

Using variable speed, the user can manually adjust the fan with multiple speeds.

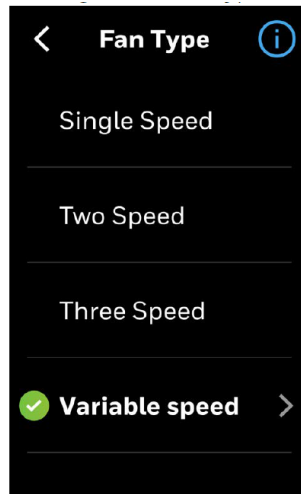
Figure 48 Variable Speed

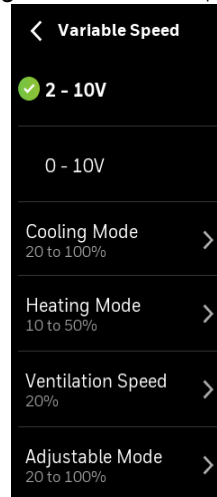

Four types of Variable Speed:

- a. Cooling Mode
- b. Heating Mode
- c. Ventilation Speed

d. Adjustable Mode

To configure Adjustable Mode setting

In Adjustable Mode, you'll find options for **Low Speed** and **High Speed**.

Figure 49 Adjustable Mode

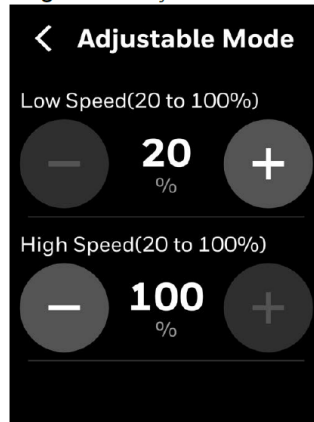

Low Speed: Currently set at 20%

High Speed: Currently set at 100%

To adjust these speeds:

Use the **+** button to increase the percentage.

Use the **-** button to decrease the percentage.

Adjust the Low Speed between 20% and 100%.

Adjust the High Speed between 20% and 100%.

1. Tap **Equipment Type**.

The Equipment type page appears.

Figure 50 Equipment type

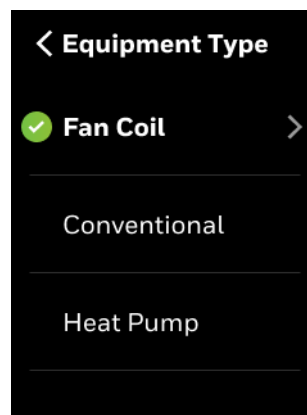

Fan coil

Note: *The fan coil equipment does not support humidifier/dehumidifier.*

1. Tap **Fan Coil**.
The Fan Coil page appears.

Figure 51 Fan coil

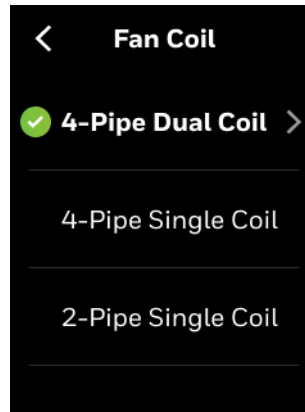

Note: *The available equipment option varies according to the thermostat models.*

4-Pipe Dual Coil

1. Tap **4-Pipe Dual Coil**.

The 4-Pipe Dual Coil screen appears.

Table 22: 4-Pipe dual coil

Valve type	Valve operation	Options	Sub options	Description
Cooling Valve	On/Off	Normally closed		Set Valve output type as N.C
		Normally Open		Set Valve output type as N.O
	*Floating			<ul style="list-style-type: none"> Set the output type as Direct or Reverse Set Valve run time Set Min position when enabled Enable sync at mid night
	Modulating	Control	Modulating control	<ul style="list-style-type: none"> Set min output when enabled. Use Stage 1 cool as enable.
		Setting	Modulating setting	<ul style="list-style-type: none"> Set output type Direct or Reverse Set Min output of Modulating valve Set Max output of Modulating valve
	Heating Valve	On/Off	Normally closed	
Normally Open				Set Valve output type as N.O
*Floating				<ul style="list-style-type: none"> Set output type as Direct or Reverse Set Valve run time Set Min position when enabled Enable sync at mid night
Modulating		Control	Modulating control	<ul style="list-style-type: none"> Set min output when enabled. Use Stage 1 heat as enable.
		Setting	Modulating setting	<ul style="list-style-type: none"> Set output type Direct or Reverse Set Min output of Modulating valve Set Max output of Modulating valve

Note: *Supported only in TC300B/TC320B models.

4-Pipe Single Coil

1. Tap 4-Pipe Single Coil.

The 4-Pipe Single Coil screen appears.

Table 23: 4-Pipe single coil

Valve type	Valve operation/ Output	Options	Description
Regulating and changeover	On/Off	Normally open	Set Valve output type as N.C
		Normally close	Set Valve output type as N.O
	*Floating	-	<ul style="list-style-type: none"> Set output type Direct or Reverse Set output type Direct or Reverse Set Min position when enabled Enable sync at mid night
	Modulating	Modulating control	<ul style="list-style-type: none"> Min output when enabled Use Stage 1 cool as enabled
Modulating setting		<ul style="list-style-type: none"> Set output type Direct or Reverse Set Min output of Modulating valve Set Max output of Modulating valve 	
Changeover	Energize on heat	-	Set Changeover relay type
	Energize on cool	-	Set Changeover relay type
6-Way Valve	2-10V	Cooling Range	<ul style="list-style-type: none"> Configure Min Output for Cooling Configure Max Output for Cooling Tap the Info icon to view the minimum allowed deadband range
		Heating Range	<ul style="list-style-type: none"> Configure Min Output for Heating Configure Max Output for Heating
		Reverse	Exchange the heating range and cooling range
	0-10V	Cooling Range	<ul style="list-style-type: none"> Configure Min Output for Cooling Configure Max Output for Cooling Tap the Info icon to view the minimum allowed deadband range
		Heating Range	<ul style="list-style-type: none"> Configure Min Output for Heating Configure Max Output for Heating
		Reverse	Exchange the heating range and cooling range

Note: *Supported only in TC300B/TC320B models.

Output range

If Output is set to 0-10 Vdc

- Heating Range: 0.0-4.7 Vdc
- Cooling Range: 5.3-10.0 Vdc
- Off voltage is 4.7-5.3Vdc

If *Output is set to 2-10 Vdc*

- Heating Range: 2.0-5.7 Vdc
- Cooling Range: 6.3-10.0 Vdc
- Off voltage is 6.0 Vdc

2-Pipe Single Coil

1. Tap 2-Pipe Single Coil.

The 2-Pipe Single Coil screen appears.

Table 24: 2-Pipe single coil

Heating/Cooling type	Controls	Options	Description
Changeover	Pipe sensor		Set the pipe sensor as input value for changeover method.
	Network Input		Set the network input as input value for changeover method.
	Changeover Switch		Set the digital input as input value for changeover method.
	Manual		
Heat & Cool	On/Off	Normally closed	<ul style="list-style-type: none"> Set Valve output type as N.C
		Normally open	<ul style="list-style-type: none"> Set Valve output type as N.O
	*Floating		<ul style="list-style-type: none"> Set output type Direct or Reverse Set Valve run time Set Min position when enabled Enable sync at mid night
	Modulating	Control	<ul style="list-style-type: none"> Set min output when enabled Use Stage 1 as enable
		Setting	<ul style="list-style-type: none"> Set output type Direct or Reverse Set Min output of Modulating valve Set Max output of Modulating valve
	Heat only	On/Off	Normally closed
Normally open			<ul style="list-style-type: none"> Set Valve output type as N.O
*Floating			<ul style="list-style-type: none"> Set output type Direct or Reverse Set Valve run time Set Min position when enabled Enable sync at mid night
Modulating		Control	<ul style="list-style-type: none"> Set min output when enabled Use Stage 1 heat as enable
		Setting	<ul style="list-style-type: none"> Set output type Direct or Reverse Set Min output of Modulating valve Set Max output of Modulating valve

Table 24: 2-Pipe single coil (Continued)

Heating/Cooling type	Controls	Options	Description
Cool only	On/Off	Normally closed	<ul style="list-style-type: none"> Set Valve output type as N.C
		Normally open	<ul style="list-style-type: none"> Set Valve output type as N.O
	*Floating		<ul style="list-style-type: none"> Set output type Direct or Reverse Set Valve run time Set Min position when enabled Enable sync at mid night
	Modulating	Control	<ul style="list-style-type: none"> Set min output when enabled Use Stage 1 cool as enable
Setting		<ul style="list-style-type: none"> Set output type Direct or Reverse Set Min output of Modulating valve Set Max output of Modulating valve 	

Note: *Supported only in TC300B/TC320B models.

Conventional

Note: This feature is applicable only to TC300B/TC320B models.

2. Tap **Equipment Type > Conventional**.
The Conventional page appears.

Figure 52 Equipment types - Conventional

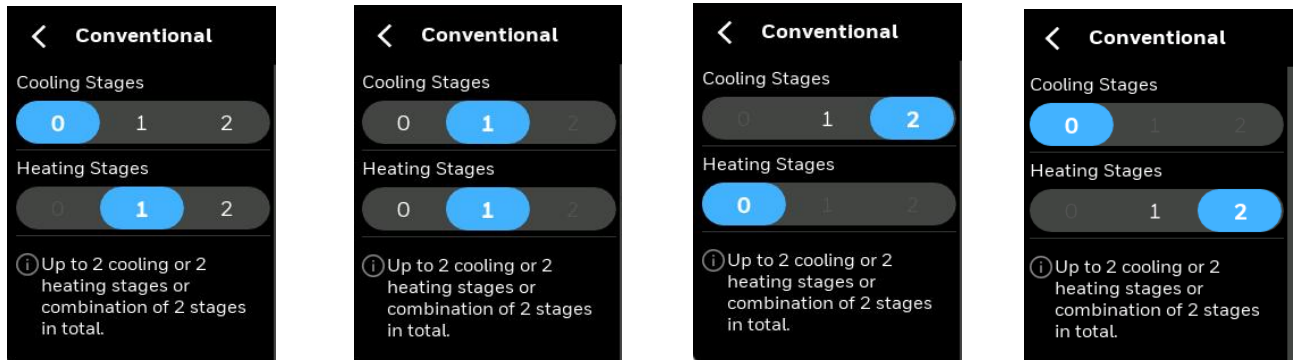

3. Select an options for conventional equipment.

Heat pump

Note: This feature is applicable only to TC300B/TC320B models. If the Heat pump source is water then set up the Proof of waterflow sensors. Refer to [Sensors](#).

4. Tap **Equipment Type > Heat Pump**.
The Heat Pump page appears.

Figure 53 Equipment type - Heat Pump

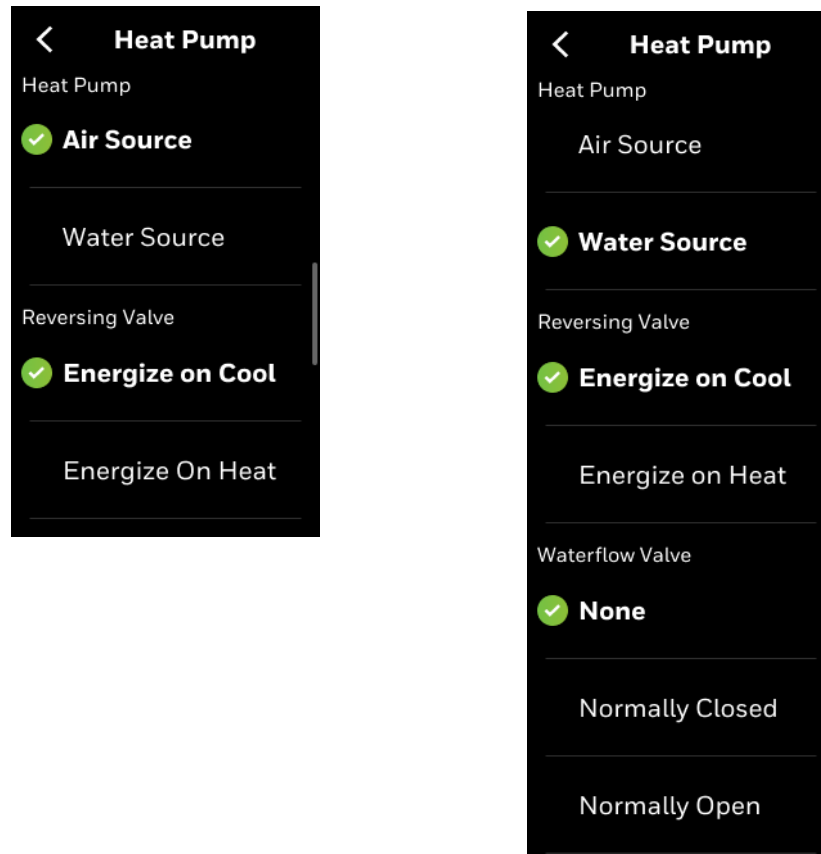

5. Select a source for heat pump. If the source is water, then select the water flow valve position.

Fan type

Note: The options for fan type varies depending on the equipment selection.

1. Swipe left from the Home screen.
2. On the Quick access screen, tap  > **Equipment** > **Equipment & I/O** > **Equipment** > **Fan Type**.
The Fan Type screen appears.

Figure 54 Fan type - Conventional/Heat pump

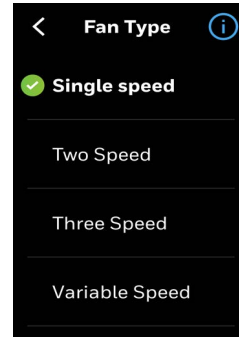

Note: The available equipment option varies according to the thermostat models.

3. Select a fan speed.
4. If the fan type is two speed and equipment is conventional.

Figure 55 Fan type - Two speed - Fan Options speed type two speed 2C

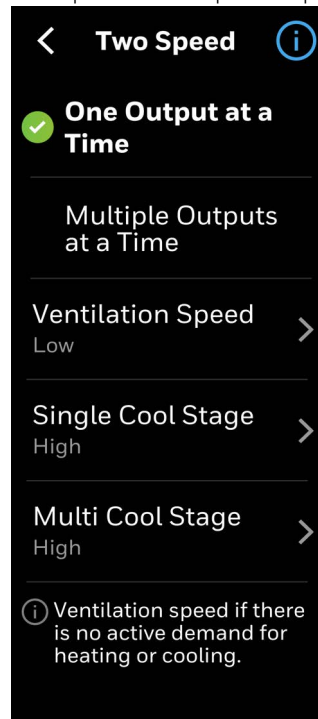

Figure 56 Fan type - Two speed - Fan Options speed type two speed 2H

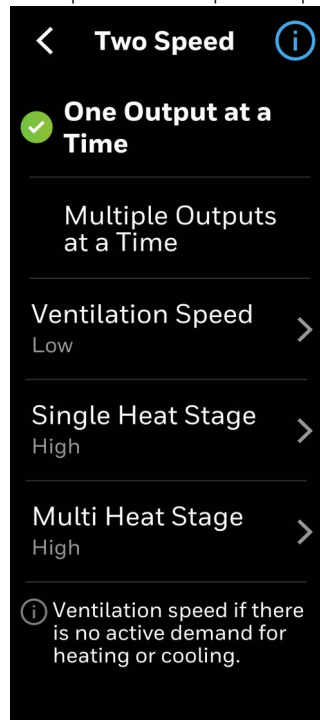
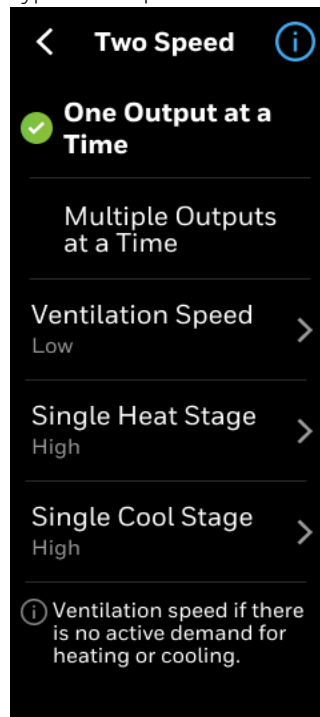

Figure 57 Fan type - Two speed - Conventional equipment



5. If the fan type is two speed and equipment is Heat pump.

Figure 58 Fan type - Two speed - Heat pump equipment

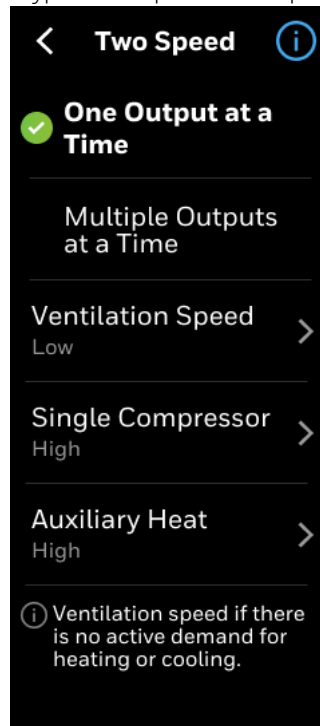



Table 25: Fan type - Two speed - Conventional equipment/ Heat pump equipment

Parameters	Description
One Output at a Time	One Output at a Time will energized the digital output assigned to current fan speed. Digital outputs assigned to other fan speed will be deenergized. Example: If fan is currently high speed, only High Speed Fan output will be active.
Multiple Outputs at a Time	Multiple Outputs at a Time will energize the digital output for the current fan speed and keep the lower speed digital outputs energized. Example: If fan is high speed, both High Speed Fan and Low Speed Fan outputs will be active.
Ventilation Speed	When an operation mode is active (e.g. VentMode), the speed selected for that mode is used to command the Fan Speed Output.
Single Heat Stage	
Single Cool Stage	
Multi Cool Stage (High, Low or Auto)	Multi Heat Stage - Will activate when Multi Cool Stage is configured as Low

Sensors

1. Swipe left from the Home screen.
2. On the Quick access screen, tap  > **Equipment** > **Equipment & I/O** > **Equipment** > **Sensors**.

The Sensors screen appears. It list the supported sensors.

Figure 59 Sensors

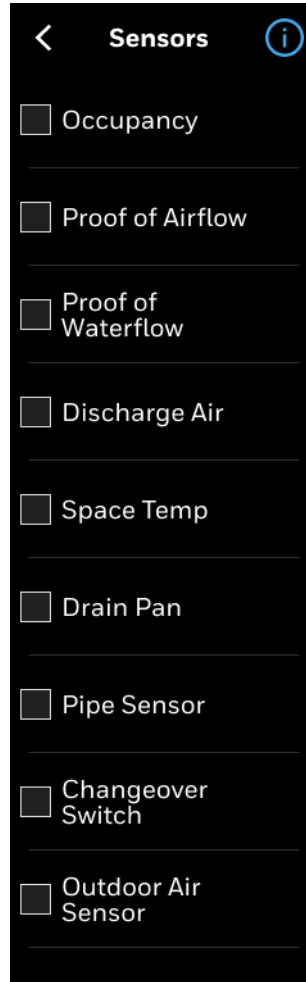

3. Tap the required sensor, relevant sub menu appears to select the settings.

Note: The desired option may be “grayed-out” whenever there are insufficient outputs to support this function. Verify I/O is configured appropriately.

Custom sensors

Three sensors can be configured by the user as a custom sensors to connect to the device and measure different types of inputs, such as digital, voltage, or temperature. The user can choose the sensor name, type, terminal, control action, and input range for each custom sensor. The thermostat supports up to three custom sensors.

Figure 60 Custom sensor

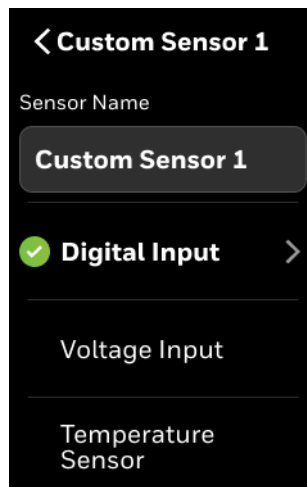

1. Enter a name in the Sensor Name field. For example: Door open. Custom Sensor 1 is the name available by default.
2. Select the input type.
3. Navigate back to the Sensor screen.
A new sensor is added in the Sensor screen with custom assigned sensor name.

Figure 61 Custom sensor - Door open

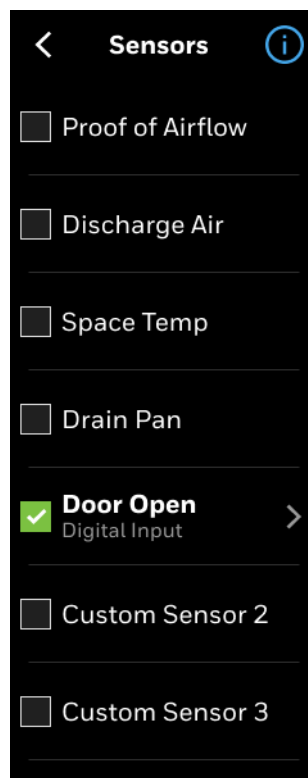

To configure Auxiliary heat

1. Swipe left from the Home screen.
2. On the Quick access screen, tap  > **Equipment** > **Equipment & I/O** > **Equipment** > select **Auxiliary Heat**.

The Mode screen appears.

Figure 62 Mode screen

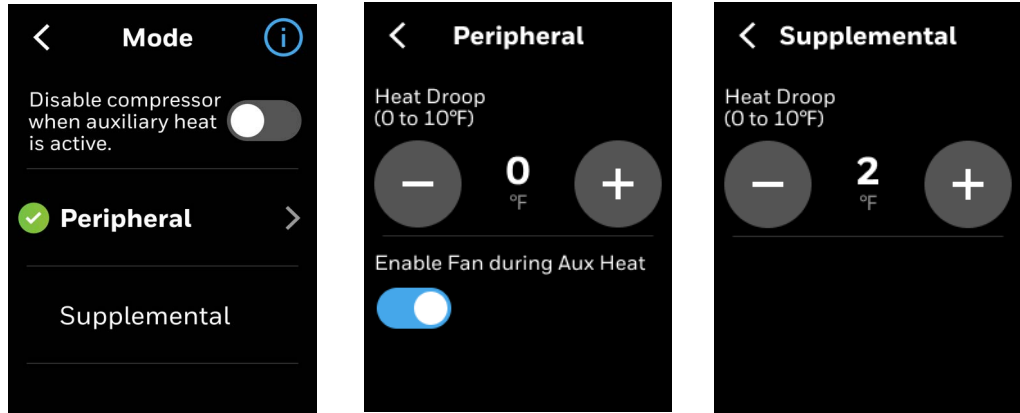

3. Set the Peripheral and Supplemental values.
Peripheral heat runs in conjunction with main fan heat cycle for improved comfort and is performed by external radiant or other heating resources.
Supplemental heat is a form of staged heating that is only initiated when primary fan coil heat function cannot maintain heating setpoint. It is also used in 2-pipe systems for heating whenever system mode is restricted to cooling only based on water temperature.

To configure Dehumidifier

1. Swipe left from the Home screen.
2. On the Quick access screen, tap  > **Equipment** > **Equipment & I/O** > **Equipment** > select **Dehumidifier**.

The Dehumidifier page appears.

Figure 63 Dehumidifier

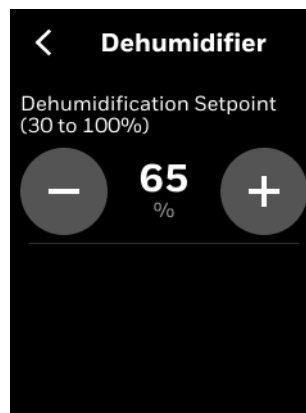

To configure Humidifier

Note: This feature is applicable only to TC300B/TC320B models.

1. Swipe left from the Home screen.
2. On the Quick access screen, tap  > **Equipment** > **Equipment & I/O** > **Equipment** > select **Humidifier**.

The Humidifier page appears.

Figure 64 Humidifier

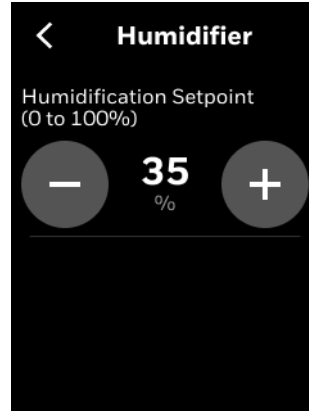

To configure Occupancy Output

Note: This feature is applicable only to TC300B/TC320B models.

1. Swipe left from the Home screen.
2. On the Quick access screen, tap  > **Equipment** > **Equipment & I/O** > **Equipment** > select **Occupancy Output**.

The Occupancy Output page appears.

Figure 65 Occupancy Output

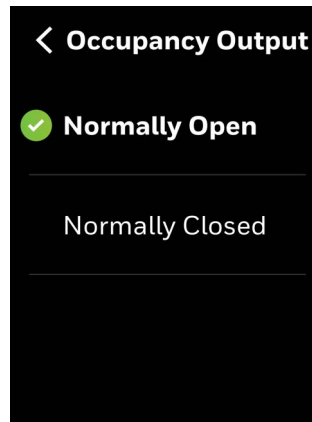

Coil Freeze Protection

To Configure Freeze Switch.

1. Swipe left from the Home screen.
2. On the Quick access screen, tap  > **Equipment** > **Sensor Settings** > **Sensor** > select **Freeze Switch**.

The Sensors screen appears.

Figure 66 Sensors

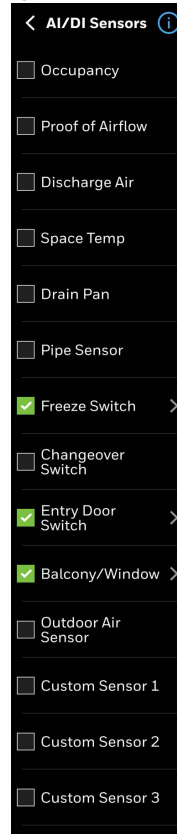

3. Drop down Freeze Switch Sensor, Freeze Switch screen appears. By default is Normally Closed.

Figure 67 Freeze Screen

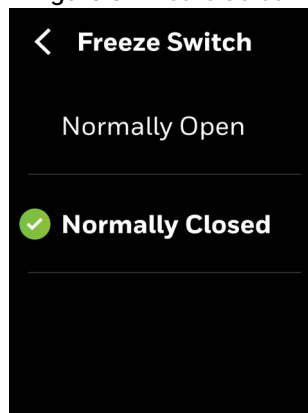

To configure I/O Assignment Freeze Switch.

4. Swipe left from the Home screen.
5. On the Quick access screen, tap  > **Equipment** > **Equipment & I/O** > **Freeze Switch**.
Select UIO1

Figure 68 I/O Assignment



To configure Alarm

6. Swipe left from the Home screen.
7. On the Quick access screen, tap  > **Alarm Preference** > **Alarm** > **Coil Freeze Protection Alarm**.
Select Coil Freeze Protection Alarm.

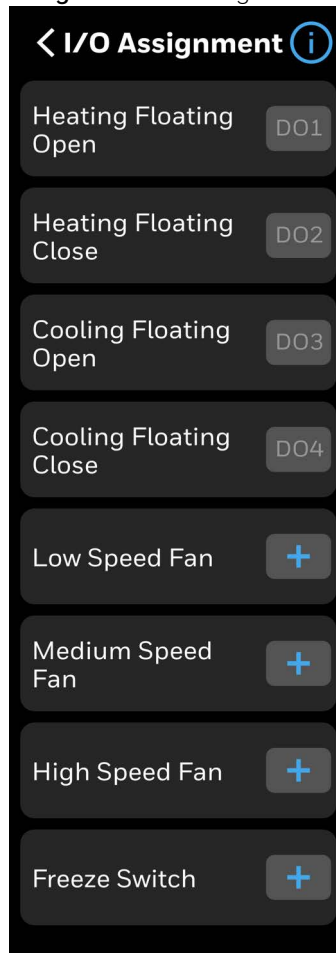
Figure 69 Alarm Preference

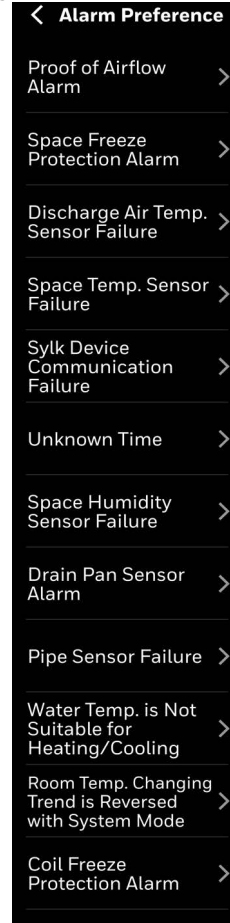

8. Coil Freeze Protection screen appears.

Figure 70 Coil Freeze Protection

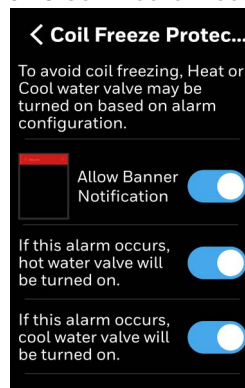

Entry Door Switch and Balcony/Window Sensor Configuration

For Hospitality Scenario, The user can configure DIO/UIO terminal as binary input to detect entry door open. When this binary input remains active for 120 seconds (30 to 300s, default 120s), Entry door open alarm will be triggered. (only for hospitality scenario). The user can configure the operation would be taken when entry door open alarm is detected.

No Action(default): This means the thermostat will not trigger an entry door open alarm. The sensor value is only used to participate in calculating the room's occupancy status.

Disable HVAC system: Besides being used in occupancy calculation, when the alarm is triggered, the thermostat will shut down all the heating, cooling and fan outputs.

Switch to Unoccupied mode: Besides being used in occupancy calculation, when the alarm is triggered, the room status will change to "Unoccupied," and the thermostat will operate in unoccupied mode.

Alarm Only: In this case, besides being used in occupancy calculation, the entry door open alarm will also be displayed, but it will not affect other control behaviors.

Figure 71 Entry Door Switch

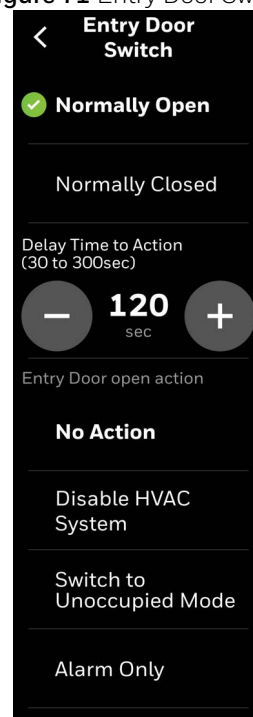

The user can configure DIO/UIO terminal as binary input to detect balcony/window open. When this binary input remains active for a certain time (30 to 300 seconds, default 120s), alarm will be triggered. The user can configure the operation would be taken when balcony/window open is detected

Disable HVAC system (default): When the alarm is triggered, the thermostat will shut down the heating, cooling, and fan outputs.

Switch to Unoccupied mode: When the alarm is triggered, the room status will change to "Unoccupied," and the thermostat will operate in unoccupied mode.

Alarm Only: In this case, the balcony/window open alarm will be displayed, but it will not affect other control behaviors.

Figure 72 Balcony/Window

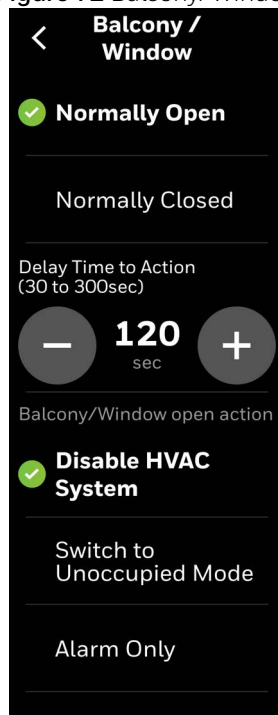

I/O terminal assignment

After connecting the thermostat to equipment, you must configure certain terminals in the thermostat so it can identify the correct purpose and apply the appropriate control schemes. The Configurable I/O tab provides options configure thermostat to the equipment and sensors wired to it. The B variant thermostats and C variant thermostats has different terminal types. For more information on terminal assignments, refer to [Terminal assignment 24 VAC \(TC300B/TC320B\)](#) section.

1. Swipe left from the Home screen.
2. On the Quick access screen, tap  > **Equipment** > **Equipment & I/O** > **I/O Assignment**
The I/O Assignment screen appears.

Figure 73 I/O Assignment

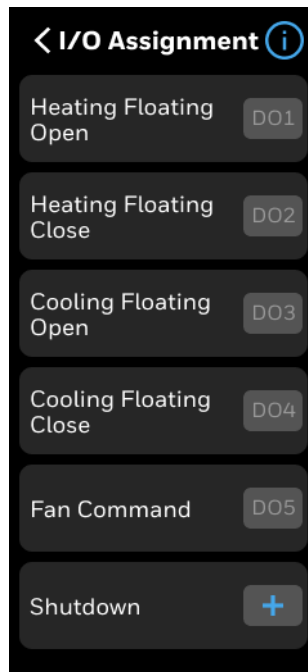

Note: The options available on the above screen varies based on the configured equipment.

3. Tap the plus button to assign the terminals.

Figure 74 Terminals for TC300B/TC320B thermostats

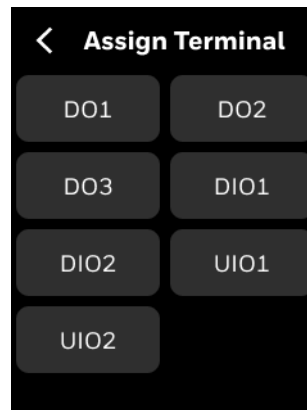
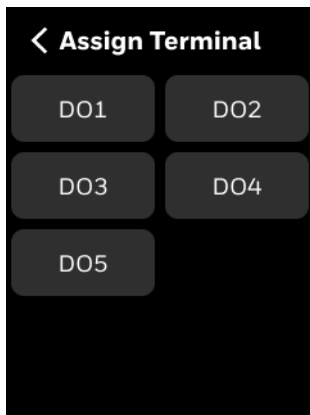
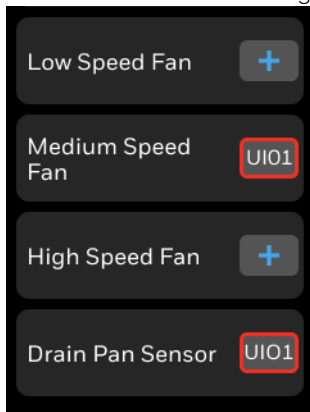

Figure 75 Terminals for TC300C/TC320C thermostats



- Based on selected equipment function the terminals will be pre-assigned. To override default terminal assignment select alternate(s) as required.
- If a terminal is assigned incorrect, then there will be a red box around the terminal button. Reassign the terminal.

Figure 76 Incorrect terminal assignment



- If the same terminal is assigned to two different functions, the user must resolve the conflict by reassigning the terminal.
- In the below example, user tried to assign UIO1 to Medium speed fan. But the terminal is already assigned to Drain pan sensor. To resolve this issue, tap the Resolve Conflict button. It opens the Drain pan sensor screen. Reassign the terminal for Drain pan sensor

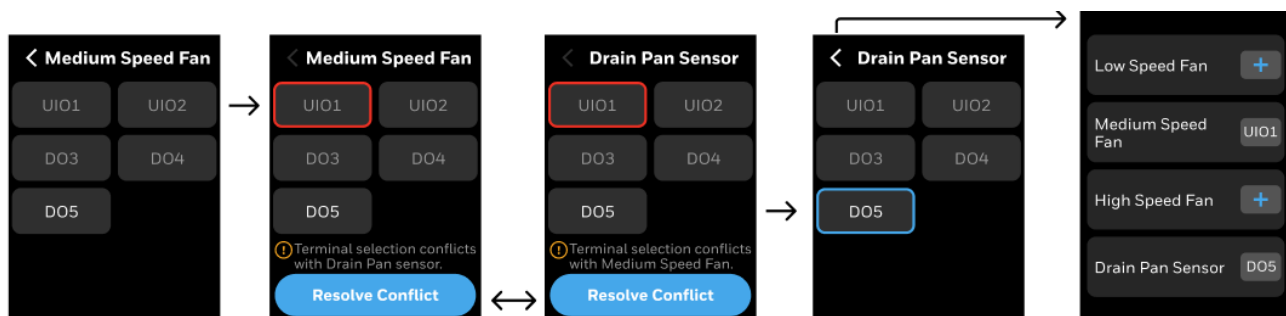

1. Tap the back button after assigning the terminals.
If the user tap the back button without modifying the terminal assignment then the following confirmation message appears.

Figure 77 Discard message

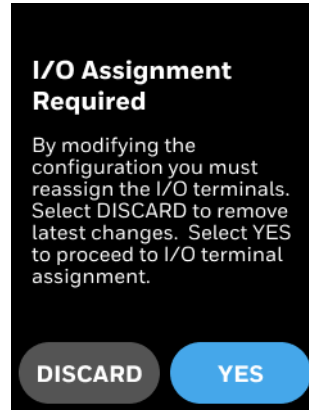

2. Tap **YES** or **DISCARD** as per the requirement.
3. A confirmation message appears, tap **YES** to confirm.

Figure 78 Typical IO assignment for equipment

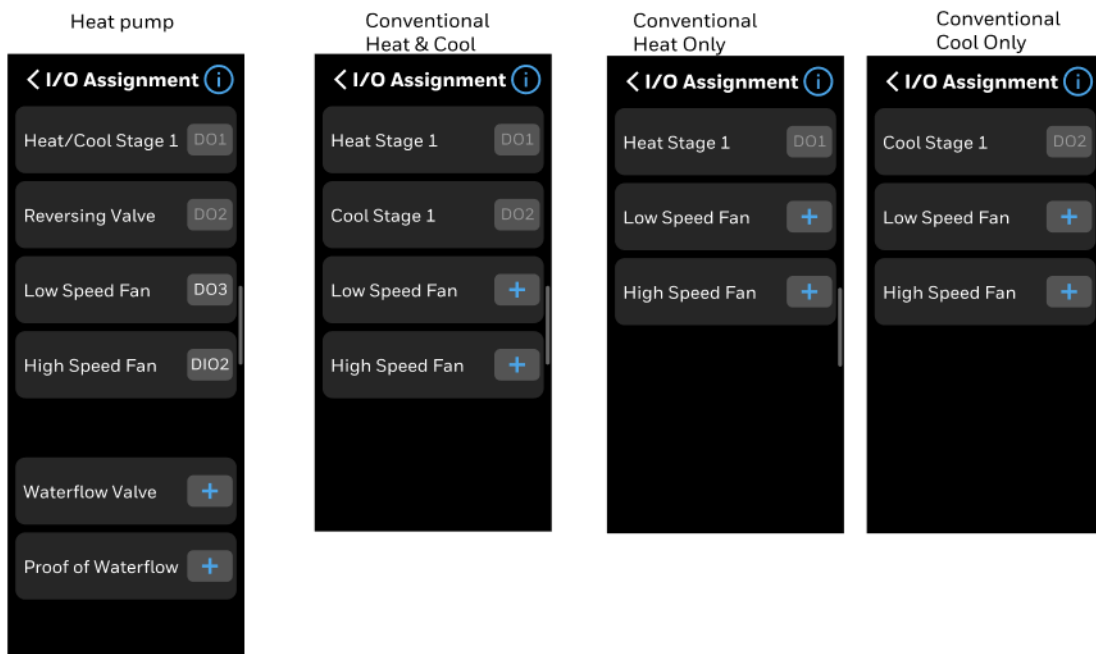

Sensors

Thermostat supports Sylk sensors and Control sensors (temperature and humidity only). In order to ensure proper operation and control, configure for Sylk devices only when using Honeywell compatible sensors.

To configure sensors

1. Swipe left from the Home screen.
2. On the Quick access screen, tap  > **Equipment** > **Sensor Settings**.
The Sensor Settings screen appears.

Figure 79 Sensor settings



3. Tap **Sensors**.
The Sensors screen appears.

Figure 80 Sensors screen

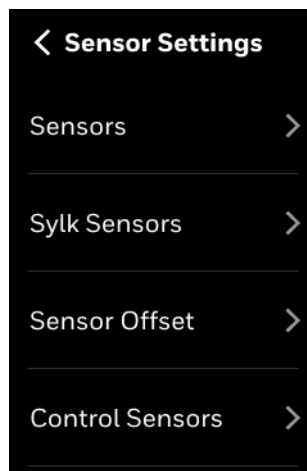
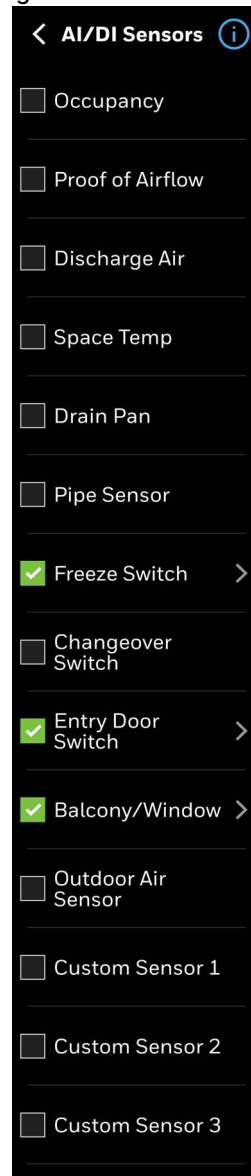

4. Scroll down to more sensors.
5. Tap the required sensor, relevant sub menu appears to select the settings.

Note: The desired option may be “grayed-out” whenever there are insufficient outputs to support this function. Verify I/O is configured appropriately.

To configure Sylk sensors

Make sure that the required Sylk devices are connected to the thermostat.

1. Swipe left from the Home screen.
2. On the Quick access screen, tap  > **Equipment** > **Sensor Settings** > **Sylk Sensors**.
A list of Sylk devices appear with the respective bus address corresponding to the address number listed in the thermostat listing.

Figure 81 Sylk devices



Note: The total number of Sylk Devices is restricted by Power and Communication bandwidth. In general, the number of Sylk devices cannot exceed the allowed limit. Contact the Honeywell Technical Support team for additional support.

3. Tap the right arrow in the menu option to view the dip switch bus address setting guide.

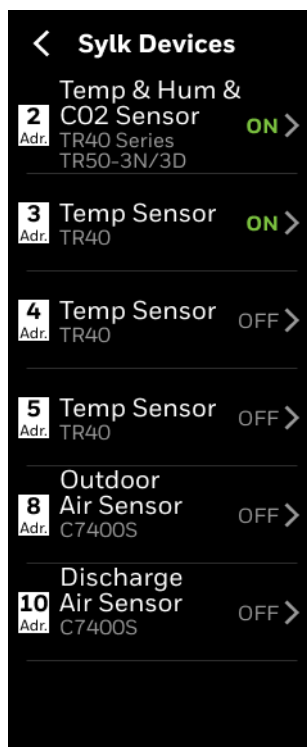
Table 26: Sylk device dip switches

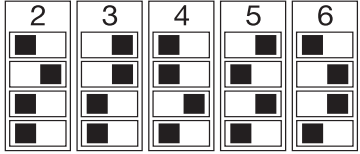
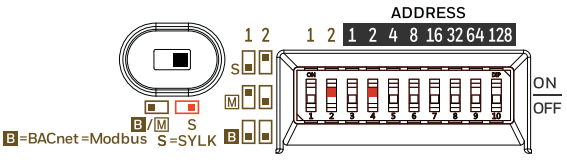
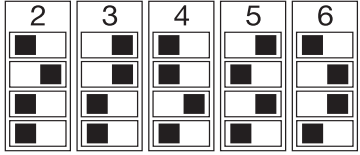
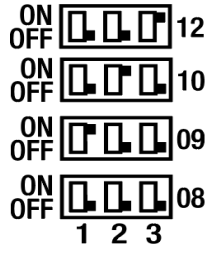
Sylk Address	Device Type	Sensors	DIP Switches
2	Sylk Temperature & Humidity & CO2 sensor	TR40 TR40-H TR40-CO2 TR40-H-CO2	
		TR50-3N TR50-3D	 <p>Note: Set the red colored switches to the position as shown in the above image</p>
3	Sylk Temperature sensor	TR40	
4	Sylk Temperature sensor	TR40	
5	Sylk Temperature sensor	TR40	
6	Sylk Wall Module	TR100 as TR75	
8	Outdoor Air Sensor	C7400S	
10	Discharge Air Sensor	C7400S	

4. Turn on the sensors.

To configure Sensor offset

1. Swipe left from the Home screen.
2. On the Quick access screen, tap  > **Equipment** > **Sensor Settings** > **Sensor Offset**.
The Sensor Offset screen appears.

Figure 82 Sensor offset

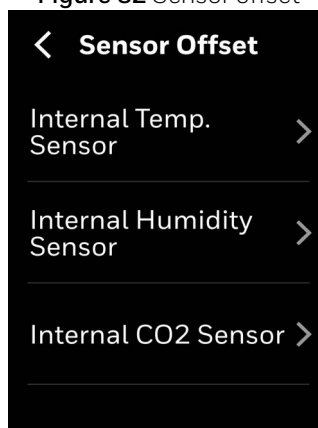

3. Set the offsets for Internal temperature sensor, Internal humidity sensor and Internal CO2 Sensor.

Figure 83 Offset screens for Temperature, Humidity and CO2

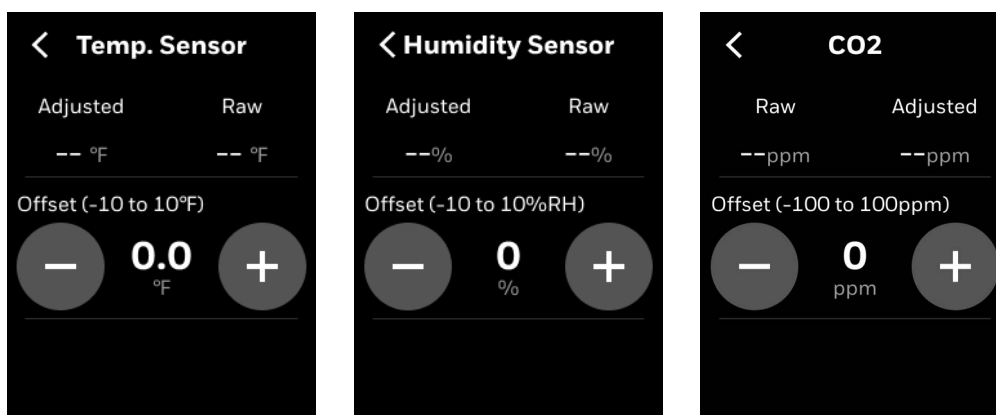

Note: These offsets should be used only when measured temperature, humidity or CO2 is verified with calibrated sensor located in same location.

To configure Control sensors

The thermostat support to configure control sensors for:Temp Humidity and CO2. The Control sensors of all three can be selected as Local sensor/Remote Sensor / Multi sensor.

Local Sensor: Internal TC300 temperature sensor. Installer can configure offsets to on-board temperature, humidity and CO2 sensors, if desired.

Remote Sensor: Space temperature sensor connected to UI/UIO terminal, or TR40 sensor configured at address 2. Remote Sensor can be configured with "suspend output" or "revert to onboard" when remote sensor fails.

Multi Sensor: Local Sensor, Terminal sensor and Sylk sensors at address 2, 3, 4, 5, 6 used together to calculate space temperature. Multi Sensor can select the multi sensors, and then configure the calculation methods.

1. Swipe left from the Home screen.
2. On the Quick access screen, tap  > **Equipment** > **Sensor** > **Control Sensors**.
The Control sensors screen appears. By default, it shows **Local Sensors**. If Remote Sensors are also configured then **Multi-Sensors** and **Remote Sensors** also appear.

Figure 84 Control sensors

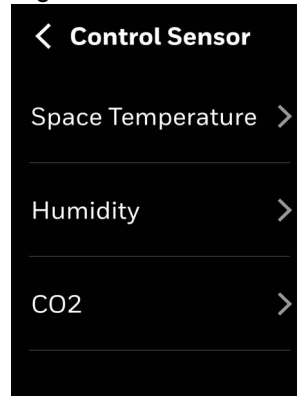

Note: If the relevant sensors not available then it will be grayed out.

Figure 85 Control Sensor screen for Space Temp, Humidity and CO2 Control

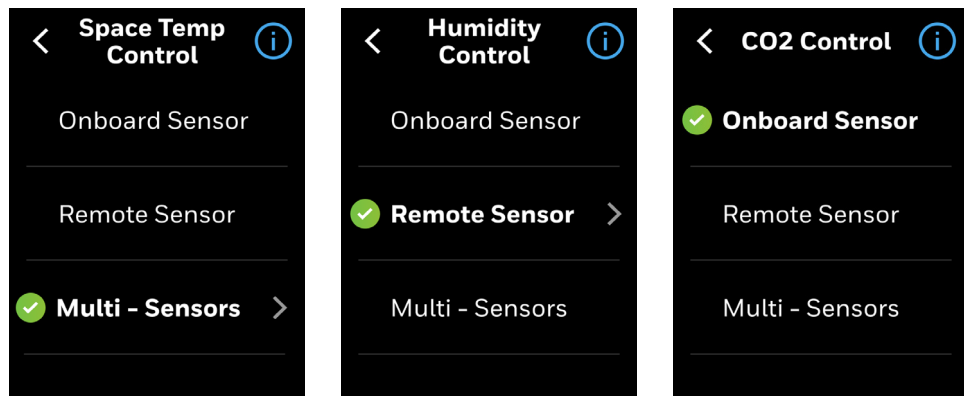

Discharge air control

The discharge air controller option is available only if the selected equipment type is Fan coil with the floating, modulating valve, or 6-way valves.

Enabling Discharge Air Temperature control will result in the thermostat regulating the floating or modulating valves to maintain discharge air temperatures (DAT) within the programmed heating or cooling limits. The discharge air temperature will automatically increase or decrease in proportion to heating or cooling demand.

During active cooling event the DAT will modulate between current cooling minus Cooling Initial Offset (default 0°F/C). Increasing cooling demand will decrease DAT until the minimum DAT setpoint is reached and then fan speed will gradually increase until maximum fan speed is reached. Cooling valves will be regulated to attempt to maintain minimum cooling DAT setpoint.

Sequence for heating is the same as cooling except initial DAT heating setpoint is setpoint plus Heating Initial Offset (default 0°F/C).

To configure Discharge air control

1. Swipe left from the Home screen.
2. On the Quick access screen, tap  > **Equipment** > **Discharge Air Control**.
The Discharge Air Control screen appears.
3. Enable the Discharge Air Control.

Figure 86 Discharge air control



4. Tap **Setpoints** to set the Maximum Heating, Heating Initial Offset, Maximum Cooling, and Cooling Initial Offset.
5. Tap **Heating Gains** to set Throttling Range and Heating Integral Time.
6. Tap **Cooling Gains** to set Throttling Range and Cooling Integral Time.

Figure 87 Discharge air control setpoints

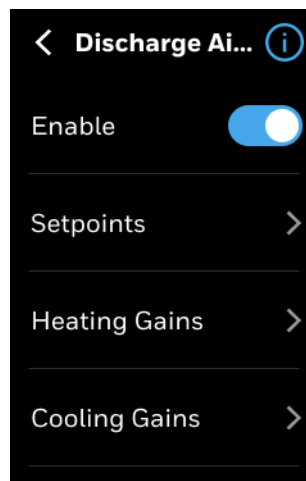
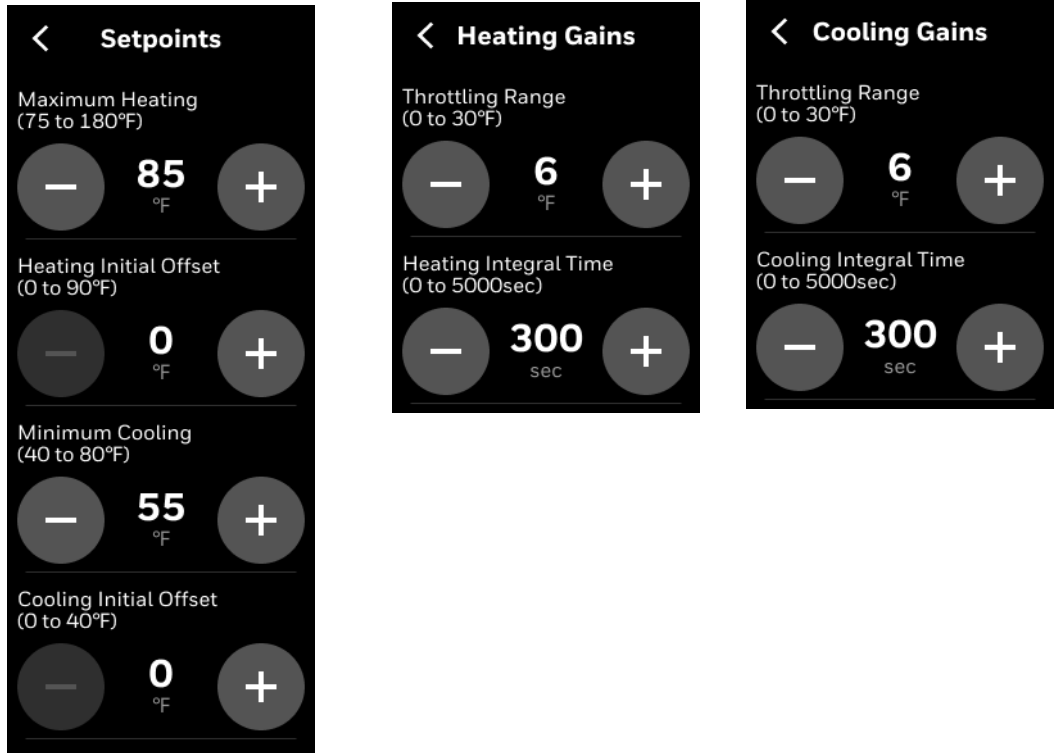

7. Tap the help icon to see the on-screen help.

Figure 88 On-screen help

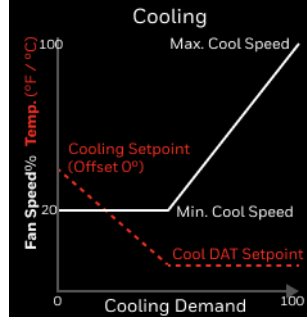

When a cooling call is initiated the DAT setpoint will start at the current cooling setpoint minus Cooling Initial Offset. As cooling demand increases the DAT setpoint will be decreased until Minimum Cooling DAT is reached. As demand increases the DAT will be maintained as the fan speed is increased until the maximum fan speed is reached.

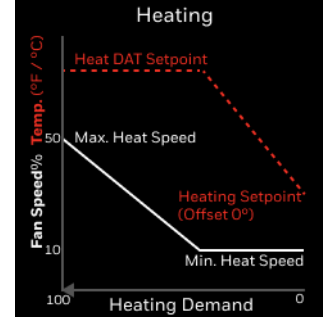

The sequence for heating is similar with the DAT setpoint starting at current heating setpoint plus Heating Initial Offset and increasing until Maximum Heating DAT is reached.

Dehumidification

Dehumidification function will maintain humidity below programmed setpoint using onboard humidity sensor. For systems without reheat the dehumidification function will allow cooling below the target setpoint based on programmed over cool offset. If humidity threshold cannot be achieved once lower space temperature threshold has been reached the dehumidification function will be suspended. For applications with reheat function setpoint will be maintained during dehumidification cycle by activating reheat using heating coil or via auxiliary heat (electric heat).

To configure dehumidification

1. Swipe left from the Home screen.
2. On the Quick access screen, tap  > **Equipment** > **Dehumidification**.
The Dehumidification screen appears. Enable the dehumidification

Figure 89 Dehumidification



Note: The Reheat option is applicable only for 4-pipe dual coil. Aux Heat for Reheat is applicable for both 4-pipe single coil and 2-pipe single coil.

3. The dehumidification icon appears on Home screen.

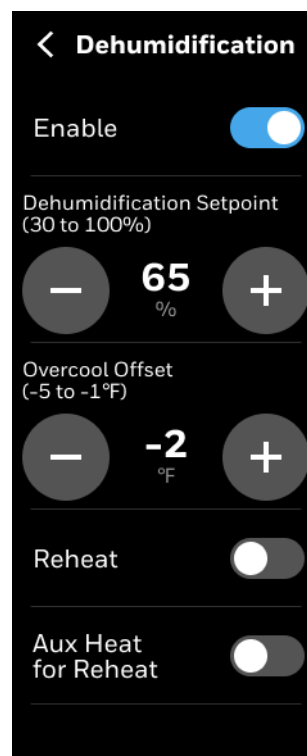
Valve cycle

Valve Cycle function is used to periodically cycle valve every 24 hours to minimize risk of sticking/binding.

To configure valve cycle

1. Swipe left from the Home screen.
2. On the Quick access screen, tap  > **Equipment** > **Valve Cycle**.
The Valve Cycle screen appears.

Figure 90 Valve cycle



Advanced configuration

The Advanced configuration screen displays all the advanced options of the thermostat.

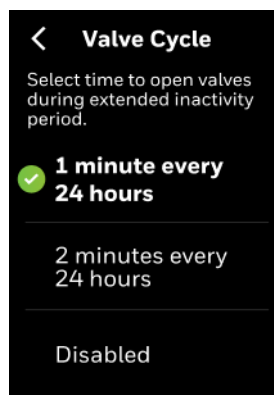
To view Advanced options

1. Swipe left from the Home screen.
2. On the Quick access screen, tap  > **Advanced**.

The Advanced configuration screen appears.

Figure 91 Advanced configuration - Equipment - Heat pump

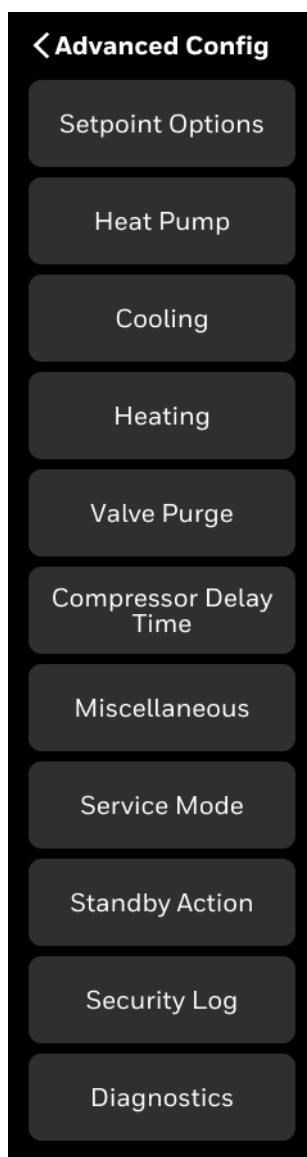

Note: The second option on the above screen changes as per equipment selected in the Equipment configuration. Also, the Cooling and the Heating tabs menus changes as per the equipment selection. Refer to [Equipment configuration](#).

Setpoint options - All equipment types

This option allows users to set the maximum or minimum temperature setpoints.

To configure setpoint options

1. Swipe left from the Home screen.
2. On the Quick access screen, tap  > **Advanced** > **Setpoint Options**.
The Setpoint options screen appears.

Figure 92 Setpoint options

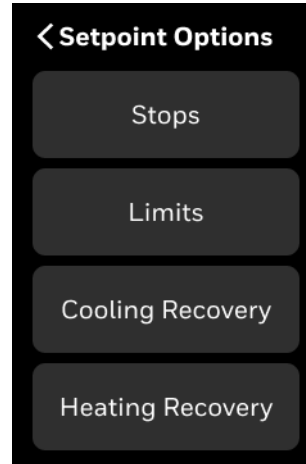

Table 27: Setpoint options

Operation	Configuration Type	Range	Description
Stops	Cooling Min. Setpoint	50-115°F (Default 90°F)	The minimum cool setpoint that can be set by the user
	Heating Max. Setpoint	40-105°F (Default 105°F)	The maximum heat setpoint can be set by the user
Limits	Thermostat Deadband	2°F-8°F (Default: 3°F)	Ensures that the heat setpoint and the cool setpoint maintain a differential minimum temperature span when the thermostat is in auto mode.
	Temporary Setpoint Limit	0°F - 45°F (Default 30°F)	The range above or below occupied setpoint by which the temperature may be altered by user from programmed scheduled setpoint in occupied state or when initiating temporary override of schedule. This includes scheduled occupancy or override of the scheduled occupancy (bypass override). During unoccupied and standby periods, the effective setpoint offset is set to 0 Δ°F. If an occupant wants to change the temporary setpoint, the occupant must first override the schedule to occupied and then the thermostat will allow the occupant to change the temporary setpoint

Table 27: Setpoint options

Operation	Configuration Type	Range	Description
Cooling Recovery	Setpoint Ramp	0 -20°F/hr (Default 6°F/hr)	When outside air temperature is available, the effective cool ramp rate is changed as the outdoor air temperature changes. When the outdoor air temperature is at the minimum cool ramp rate temperature (e.g. 90°F) and above, the effective cool ramp rate is at the minimum cool ramp (e.g. 2 Δ°F/hr). When the outdoor air temperature falls, the cool ramp rate is lowered until the maximum cool ramp temperature (e.g. 70°F) is reached or above, the effective cool ramp is at the maximum cool ramp rate (e.g. 6 Δ°F/hr).
Heating Recovery	Setpoint Ramp	0 -36°F/hr (Default 8°F/hr)	When outside air temperature is available, the effective heat ramp rate is changed as the outdoor air temperature changes. When the outdoor air temperature is at the minimum heat ramp rate temperature (e.g. 0°F) and below, the effect heat ramp rate is at the minimum heat ramp (e.g. 2 Δ°F/hr). When the outdoor air temperature is at the maximum heat ramp temperature (e.g. 60°F) and above, the effective heat ramp is at the maximum heat ramp rate (e.g. 8 Δ°F/hr).

Heat pump

Note: This feature is applicable only to TC300B/TC320B models. This option is available only when the equipment is configured as Heat pump. Refer to [Equipment configuration](#).

To configure Heat pump

1. Swipe left from the Home screen.
2. On the Quick access screen, tap  > **Advanced** > **Heat Pump**.
The Heat Pump screen appears.

Figure 93 Heat pump

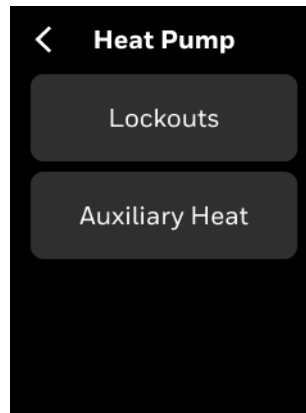

Table 28: Heat pump

Type	Configuration Type	Range	Description
Lockouts (only for air source heat pump)	Compressor Lockout	0 to 70°F (Default 30°F)	During heating mode, when the outside air temperature is below the Heat Pump Compressor Lockout setpoint, the compressor stages are disabled and the auxiliary heating is allowed to run.
	Auxiliary Heat Lockout	30 to 120°F (Default 65°F)	During heating mode, when the outside air temperature is above the Heat Pump Aux Heat Lockout setpoint, the auxiliary stages will be disabled. However, if the compressors are locked out by outside air temperature or the unit is commanded to emergency heat mode, the auxiliary heat stages are allowed to run.

Table 28: Heat pump

Type	Configuration Type	Range	Description
Auxiliary Heat	Aux Heat Ramp Factor	0 to 100 (Default 2)	Ramp is used when the thermostat is recovering from the unoccupied setpoint. To avoid the auxiliary heat stages from being used during this period, the user can specify an auxiliary heat ramp factor. This creates a second recovery ramp setpoint for the auxiliary heat. If the heat compressors cannot maintain its recovery ramp or are locked out when the outside air temperature is low, the auxiliary heat ramp will be used to allow auxiliary heat to recover before the occupied period.
	Enable Aux Heat Delay Aux Heat Delay	30 to 960 minutes (Default 30 min)	This timer starts when the highest stage of the previous heating equipment type turns on. Aux Heat will be used (if needed) when the timer expires.

Cooling options - For Heat pump & Conventional equipment

Note: This feature is applicable only to TC300B/TC320B models.

To configure cooling options

1. Swipe left from the Home screen.
2. On the Quick access screen, tap  > **Advanced** > **Cooling**.
The Cooling Options screen appears.

Figure 94 Cooling options-For Heat pump & Conventional equipment

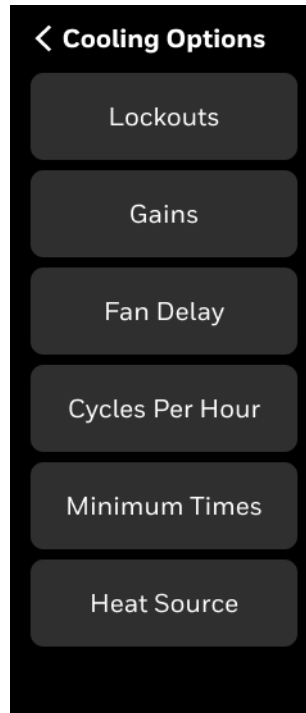

Table 29: Cooling options-For Heat pump & Conventional equipment

Cooling type	Configuration Type	Range	Description
Lockouts	DAT Cooling Low Limit	-40 to 60°F (Default 45°F)	When the discharge air temperature is below the discharge air low limit setpoint, the cooling control will turn off stages of cool until the discharge air temperature rises above it's setpoint plus a 2 °F differential.
	OAT Cooling Lockout	-40 to 120°F (Default 35°F)	When the outside air temperature is below the cooling lockout setpoint, the cooling control will be disabled. When the outside air temperature is above the cooling lockout setpoint plus 2 °F differential, the cooling control is enabled.

Table 29: Cooling options-For Heat pump & Conventional equipment

Cooling type	Configuration Type	Range	Description
Gains	Throttling Range	0 to 30°F (Default 4°F)	The throttling range is the amount of change in the sensed temperature required to drive the output from 0 to 100%. The throttling range must be narrow enough to provide good control without becoming unstable. The throttling range is determined by factors including: the control application, heating or cooling capacity of the equipment relative to the physical size of the space being controlled, and the control algorithm being used. The narrower (smaller) the throttling range, the more precise the control and the wider (larger) the throttling range, the more stable the control. The objective is setting the throttling range to achieve the optimum balance between precision and stability.
	Cooling Integral Time	0 to 5000 Sec (Default 2500 Sec)	The amount of time the error has continued uncorrected. Integral action corrects the temperature control errors of proportional-only control, but it is slower to react to large temperature or setpoint changes.
Fan Delay	Fan Off Delay Time	0-180 Sec	Fan run on time after all cooling outputs are turned off. May be used to run fan after all cooling outputs have turned off so that the cooling coil can warm up before the fan turns off to prevent condensation from evaporating into the space.
Cycles Per Hour	Cooling Cycles Per Hour	2 to 20CPCH (Default 3CPH)	The frequency at which the system starts and stops within one hour
Minimum Times	Cooling Min.Off Time	0 to 300 Sec (Default 60 Sec)	Cooling Stage Minimum On/Off Time: Wait before a Cooling Stage can be turned on/off after it has been turned off/on, to prevent possible damage if the compressor is restarted too quickly.
	Cooling Min.On Time	0 to 300 Sec (Default 120 Sec)	

Cooling options - For Fan coil equipment

To configure cooling options

1. Swipe left from the Home screen.
2. On the Quick access screen, tap  > **Advanced** > **Cooling**.
The Cooling Options screen appears.

Figure 95 Cooling options-For Fan coil equipment

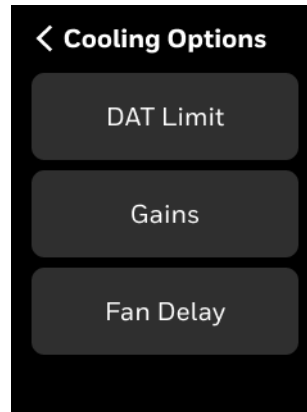

Table 30: Cooling options-For Fan coil equipment

Cooling type	Configuration Type	Range	Description
DAT Limit	DAT Cooling Low Limit	-40 to 60°F (Default 45°F)	When the discharge air temperature is below the discharge air low limit setpoint, the cooling control will turn off cooling physical output until the discharge air temperature rises above it's setpoint +2 °F differential.
Gains	Throttling Range	0 to 30°F (Default 10°F)	The throttling range is the amount of change in the sensed temperature required to drive the output from 0 to 100%. The throttling range must be narrow enough to provide good control without becoming unstable. The throttling range is determined by factors including: the control application, heating or cooling capacity of the equipment relative to the physical size of the space being controlled, and the control algorithm being used. The narrower (smaller) the throttling range, the more precise the control and the wider (larger) the throttling range, the more stable the control. The objective is setting the throttling range to achieve the optimum balance between precision and stability.
	Heating Integral Time/ Cooling Integral Time	0 to 5000 Sec (Default 2500 Sec)	The amount of time the error has continued uncorrected. Integral action corrects the temperature control errors of proportional-only control, but it is slower to react to large temperature or setpoint changes.

Table 30: Cooling options-For Fan coil equipment

Cooling type	Configuration Type	Range	Description
Fan Delay	Fan Off Delay Time	0-180 Sec	Fan run on time after all cooling outputs are turned off. May be used to run fan after all cooling outputs have turned off so that the cooling coil can warm up before the fan turns off to prevent condensation from evaporating into the space.

Heating options - For Heat Pump and Conventional equipment

Note: This feature is applicable only to TC300B/TC320B models.

To configure cooling options

1. Swipe left from the Home screen.
2. On the Quick access screen, tap  > **Advanced** > **Heating**.
The Heating Options screen appears.

Figure 96 Heating options - For Fan coil equipment

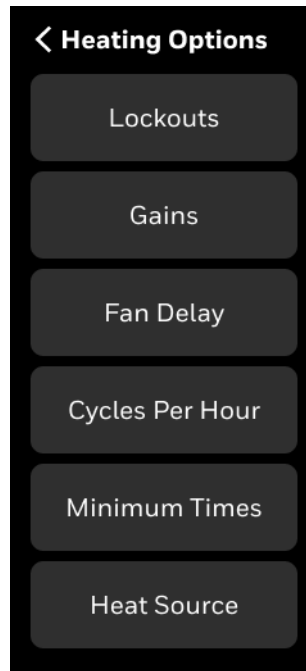

Table 31: Heating options-For Heat pump & Conventional equipment

Heating type	Configuration Type	Range	Description
Lockouts	DAT Heating High Limit	60 to 200°F (Default 150°F)	When the discharge air temperature is above the discharge air high limit setpoint, the heating control will turn off stages of heat until the discharge air temperature falls below its setpoint minus a 2 °F differential. This will help prevent the discharge air temperature from getting too hot and avoid tripping limits.
	OAT Heating Lockout	40 to 120°F (Default 70°F)	OAT Heating lockout set points defined as when outside air is above the lockout, it will not allow heating to be enabled. When the outside air temperature is below the heating lockout setpoint less a 2 °F differential, the heating control is enabled.

Table 31: Heating options-For Heat pump & Conventional equipment (Continued)

Heating type	Configuration Type	Range	Description
Gains	Throttling Range	0 to 30°F (Default 4°F)	The throttling range is the amount of change in the sensed temperature required to drive the output from 0 to 100%. The throttling range must be narrow enough to provide good control without becoming unstable. The throttling range is determined by factors including, the control application, the response time of the equipment being controlled, and the control algorithm being used. The narrower (smaller) the throttling range, the more precise the control and the wider (larger) the throttling range, the more stable the control. The objective is setting the throttling range to achieve the optimum balance between precision and stability.
	Heating Integral Time/ Cooling Integral Time	0 to 5000 Sec (Default 2500 Sec)	The amount of time the error has continued uncorrected. Integral action corrects the temperature control errors of proportional-only control, but it is slower to react to large temperature or setpoint changes
Fan Delay	Fan Off Delay Time	0 to 180 Sec (Default 120 Sec)	Fan run on time after all heating outputs are turned off. May be used to run fan after all heating outputs have turned off so that the heat coil can cool down before the fan turns off.
Cycles Per Hour	Heating Cycles Per Hour	2 to 20 CPH (Default 6 CPH)	Heating cycles per hour is a setting that determines how often the heating system turns on and off to maintain the desired temperature. It can be adjusted by the user to optimize comfort and energy efficiency.
Minimum Times	Heating Min.Off Time	0 to 300 Sec (Default 60 Sec)	Heating Stage Minimum On/Off Time: Wait before a Heating Stage can be turned on/off after it has been turned off/on, to prevent possible damage if the compressor is restarted too quickly.
	Heating Min.On Time	0 to 300 Sec (Default 120 Sec)	
Heat Source	Gas/Oil	2-20CPH (Default 6)	Heating cycles per hour is a setting that determines how often the heating system turns on and off to maintain the desired temperature. It can be adjusted by the user to optimize comfort and energy efficiency.
	Electric (Heating Cycles Per Hour)	2 to 20 CPH (Default 9)	

Heating options - For Fan coil equipment

To configure cooling options

1. Swipe left from the Home screen.
2. On the Quick access screen, tap  > **Advanced** > **Heating**.
The Heating Options screen appears.

Figure 97 Heating options - For Fan coil equipment



3. Tap **Fan Control**,
The Fan Control screen appears.

Figure 98 Fan Control

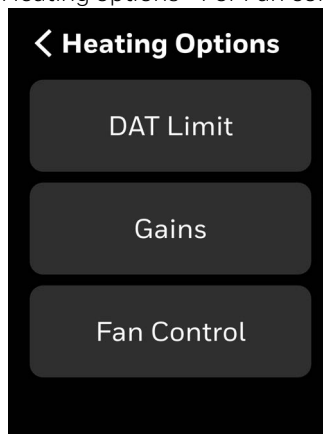
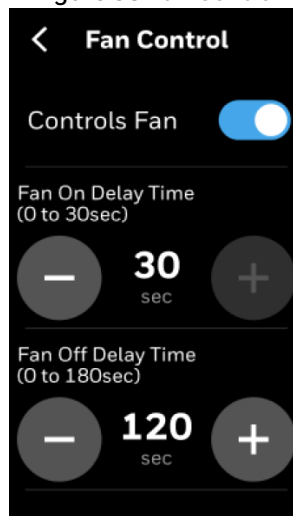

Table 32: Heating options-For Fan coil equipment

Heating type	Configuration Type	Range	Description
DAT Limit	DAT Heating High Limit	-60 to 200°F (Default 150°F)	When the discharge air temperature is above the discharge air high limit setpoint, the heating control will turn off heating physical output until the discharge air temperature falls below it's setpoint -2 °F differential. This will help prevent the discharge air temperature from getting too hot and avoid tripping limits.
Gains	Throttling Range	0 to 30°F (Default 10°F)	The throttling range is the amount of change in the sensed temperature required to drive the output from 0 to 100%. The throttling range must be narrow enough to provide good control without becoming unstable. The throttling range is determined by factors including, the control application, the response time of the equipment being controlled, and the control algorithm being used. The narrower (smaller) the throttling range, the more precise the control and the wider (larger) the throttling range, the more stable the control. The objective is setting the throttling range to achieve the optimum balance between precision and stability.
	Heating Integral Time/ Cooling Integral Time	0 to 5000 Sec (Default 2500 Sec)	The amount of time the error has continued uncorrected. Integral action corrects the temperature control errors of proportional-only control, but it is slower to react to large temperature or setpoint changes
Fan Delay	Fan On Delay Time	0 to 30 Sec (Default 30)	Fan on delay time after heating outputs are turned on. May be used to run fan after heating outputs have turned on for some times so that heating coil can warm up.
	Fan Off Delay Time	0 to 180 Sec (Default 120 Sec)	Fan run on time after all heating outputs are turned off. May be used to run fan after all heating outputs have turned off so that the heat coil can cool down before the fan turns off.

Pipe sensor thresholds

This feature is suitable for heating when pipe temperature is above threshold, and suitable for Cooling when pipe temperature is below threshold.

To configure Pipe sensor thresholds

1. Swipe left from the Home screen.
2. On the Quick access screen, tap  > **Advanced** > **Pipe Sensor Thresholds**.
The Pipe Sensor Thresholds screen appears.

Figure 99 Pipe Sensor Thresholds

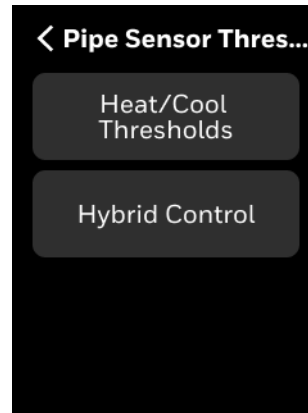

Table 33: Pipe sensor threshold

Operation	Configuration Type	Range	Description
Heat/Cool Thresholds (Standard)	Pipe Sensor Threshold for Heating	70 to 90°F (Default 80°F)	When the pipe temperature is above the threshold, it is suitable for heating.
	Pipe Sensor Threshold for Cooling	45 to 65°F (Default 60°F)	When the pipe temperature is below the threshold, it is suitable for cooling.

Table 33: Pipe sensor threshold (Continued)

Operation	Configuration Type	Range	Description
Hybrid Control	Temp Offset (Heat)	5 to 10°F (Default 5°F)	When the pipe temperature is above the space temperature and the hybrid control is enabled, than the offset is suitable for heating.
	Timeout Timer (Heat)	1 to 4 hours (Default 4 hours)	When the configured timer expires, the pipe sensor reading is compared to the threshold setting, if the pipe sensor reading is above the threshold, it will generate water temperature. No heating alarm will be raised.
	Temp Offset (Cool)	-10 to -5°F (Default -5°F)	When the pipe temperature is below the space temperature and the hybrid control is enabled, than the offset is suitable for cooling.
	Timeout Timer (Cool)	1 to 4 hours (Default 4 hours)	When the configured timer expires, the pipe sensor reading is compared to the threshold setting, if the pipe sensor reading is below the threshold, it will generate water temperature. No cooling alarm will be raised.

Valve purge

This setting for 2-pipe systems cycles valve to ensure accurate changeover temperature sensor reading if there are infrequent heating or cooling cycles.

To configure Valve purge

1. Swipe left from the Home screen.
2. On the Quick access screen, tap  > **Advanced** > **Valve Purge**.
The Valve Purge screen appears.

Figure 100 Valve purge



3. Set the purge time and interval.

Compressor delay time

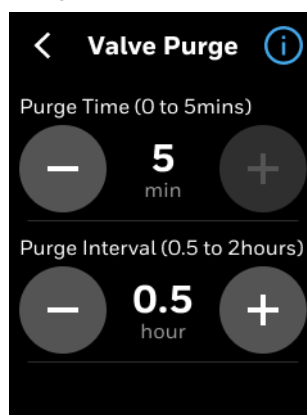
Note: This feature is applicable only to TC300B/TC320B models.

For water source heat pump applications the compressor delay time ensures the water valve can be fully opened when controlled by thermostat before activating the compressor heat or cool command.

To configure compressor delay time

1. Swipe left from the Home screen.
2. On the Quick access screen, tap  > **Advanced** > **Compressor Delay Time**.
The Compressor Delay screen appears.

Figure 101 Compressor delay time

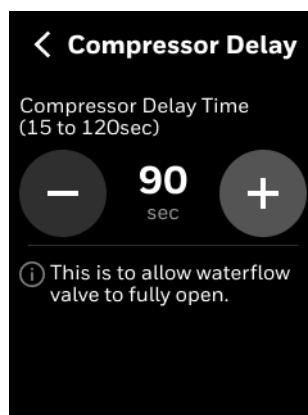

Miscellaneous

To configure miscellaneous

1. Swipe left from the Home screen.
2. On the Quick access screen, tap  > **Advanced** > **Miscellaneous**.
The Miscellaneous screen appears.

Figure 102 Miscellaneous



3. Power Up Delay Time - The thermostat will perform a delayed after controller power up. User can set 0 to 300 Sec delay. The default is 10 seconds.
4. Force Exit Provisional - After updating the firmware, the device enters a provisional stage for approximately 35 minutes to ensure stable system operation. During this time, it is not possible to perform another firmware upgrade. However, there is an option to force the device to exit the provisional stage, allowing for continuous firmware upgrades.

Caution: Exercise caution when using the Force Exit Provisional option at your site.

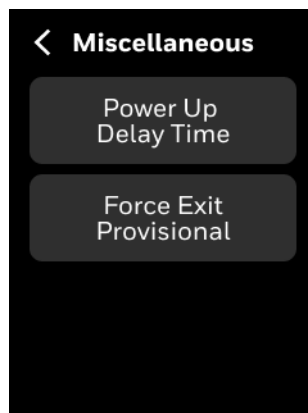
Service mode

Service mode disables all control algorithms to perform service of the equipment. It also provides options to test the terminals for intended output by connecting the test equipment to the terminal and run the algorithm manually.

To enable service mode

1. Swipe left from the Home screen.
2. On the Quick access screen, tap  > **Advanced** > **Service Mode**.
The Service mode YES or NO screen appears, tap YES to enable Service mode.

Figure 103 Service mode enabling

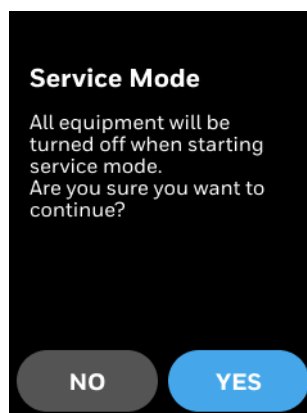

- The Service Mode screen appears, tap Occupancy sensor.

Figure 104 Service Mode

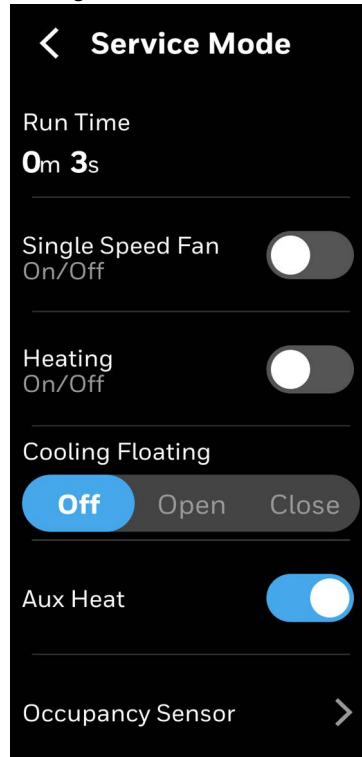

- The Occupancy Sensor YES or NO screen appears, tap YES to enable Occupancy Sensor test mode.

Figure 105 Occupancy Sensor Enabling

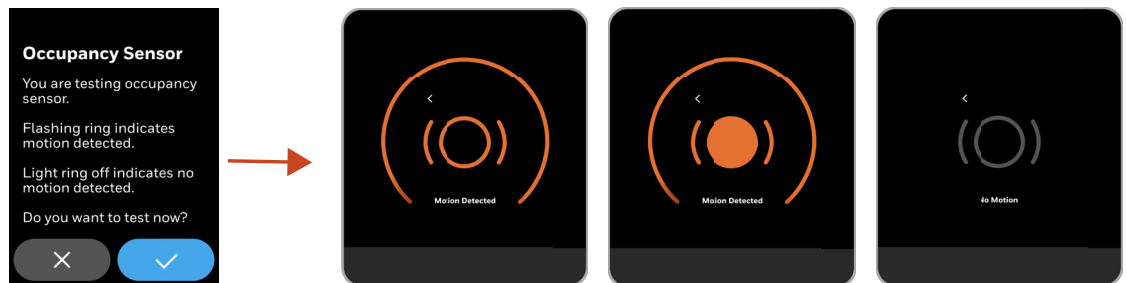

Based on terminal configuration, the following screen displays different options for manual testing. For example, in below screen, single speed fan, Heating equipments, Cooling floating, and Aux heat equipments are configured. Connect these test equipment to the relevant terminals and test for actual output.

Figure 106 Service mode

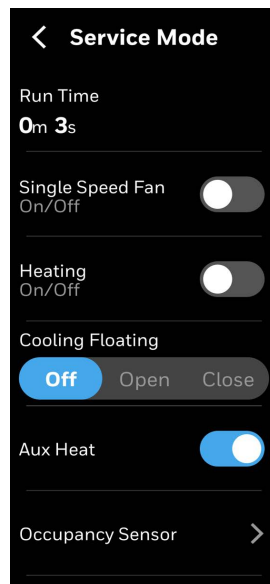

5. Connect the relevant equipment to the terminal and test its functionality.
6. For more examples, in below images, typical options for two speed fan, variable fan, modulating heat, 6-way valve to test its functionality.

Figure 107 Typical service mode options

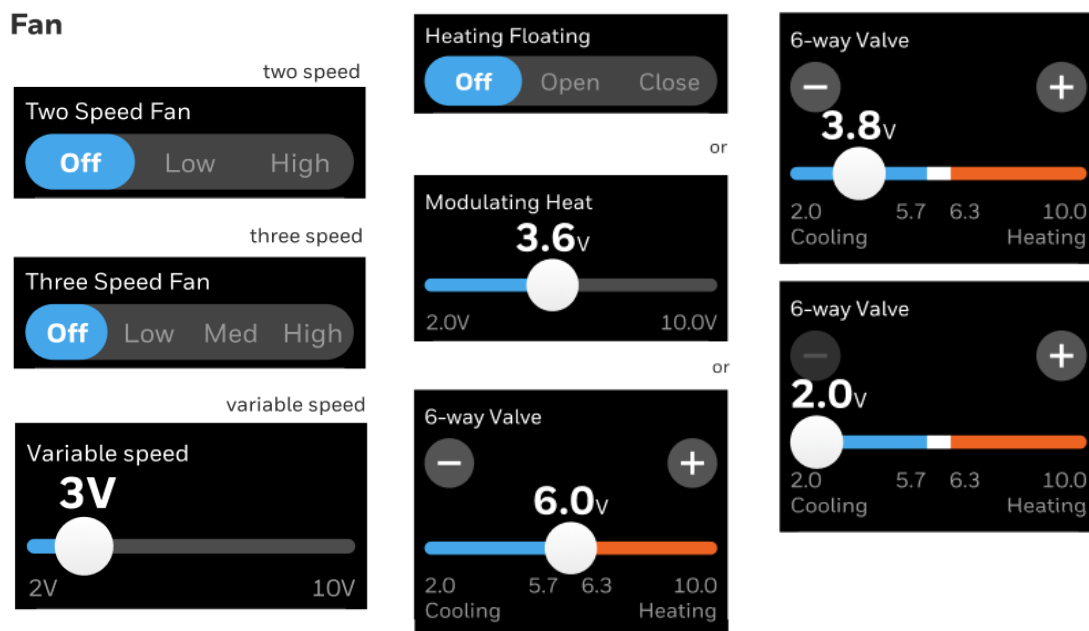

7. To exit the service mode, on the service mode screen, tap the back arrow button. A confirmation message appears.

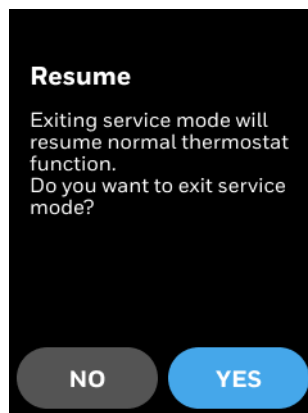
Figure 108 Service mode exit

8. Tap **YES**.
The service mode will exit and thermostat resume normal function.

Standby action

The Standby Action refers to which mode setpoints to be used while the thermostat is in Standby mode. You can select either Occupied mode or Unoccupied mode.

To set up Standby action

1. Swipe left from the Home screen.
2. On the Quick access screen, tap  > **Advanced** > **Standby Action**.
The Standby Action screen appears.

Figure 109 Standby action

3. Tap Treat as Occupied or Treat as Unoccupied.

Security log

The security log contains records of the critical security events such as password change, user role switch, firmware upgrade Cooling integral time, DAT Heating high limit, standby action, OTA Lockout, Service Mode and so on.

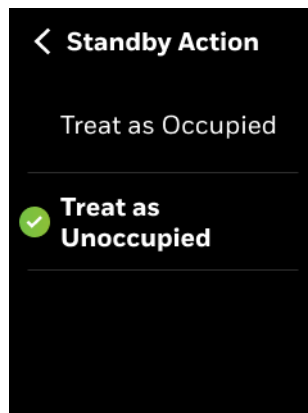
To view the security log

1. Swipe left from the Home screen.
2. On the Quick access screen, tap  > **Advanced** > **Security Log**.
The Security Log screen appears.

Figure 110 Security log



Diagnostics

The diagnostics information of the thermostat helps to service the device based on the log information.

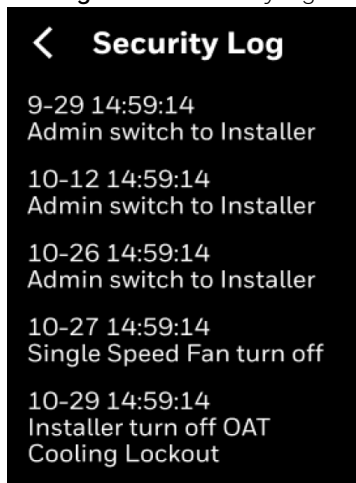
To view the Diagnostics

1. Swipe left from the Home screen.
2. On the Quick access screen, tap  > **Advanced** > **Diagnostics**.
The Diagnostics screen appears.

Figure 111 Diagnostics



3. Forge - Cloud registration information
4. Azure - Azure connection and upgrade information.
5. Log info - Log info of thermostat like device restart and other exception issues.
6. Memory Usage - Memory usage of the firmware.
7. Application Info - Application info shows DDC runtime.
8. Thermal Info - Thermal information of the connected devices.
9. Application Restore - Tap to restore the application that is loaded into the thermostat. It will restore the application by removing all existing configurations.

Connection

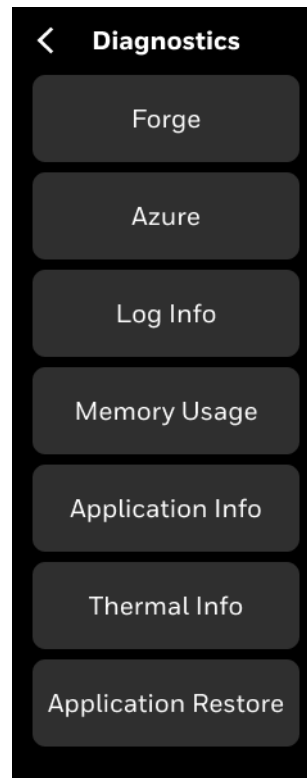
All TC300 thermostats may be connected via RS485 and wired connections. The Wi-Fi connections support Internet and BACnet IP simultaneously or separately. The wired connections support BACnet MS/TP and Modbus connections separately.

TC320 models support Wi-Fi connectivity. This includes simultaneous BACnet IP and mobile app cloud connectivity plus Over-The-Air (OTA) firmware updates. Bluetooth is used for cybersecurity device protection during registration. For the supported connection types in the various thermostat models, please refer to [TC300 Models](#).

Notes:

- BACnet MS/TP cannot be enabled when Modbus is enabled and vice versa.
- BACnet MSTP cannot be enabled when BACnet IP is enabled and vice versa.
- BACnet IP and Modbus can be enabled simultaneously.
- Internet (via Wi-Fi) and BACnet MST/TP can enabled simultaneously.
- Internet (via Wi-Fi) and Modbus can enabled simultaneously.

To enable Wi-Fi and connecting to Internet

1. Swipe left from the Home screen.
2. On the Quick access screen, tap  > **Connection**.
The Connection screen appears.

Figure 112 BACnet MS/TP connection



3. Tap the **Wi-Fi**.
4. Enable Wi-Fi.
The Wi-Fi page appears.

Figure 113 Wi-Fi

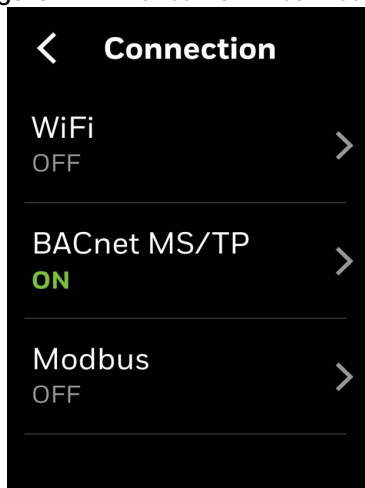
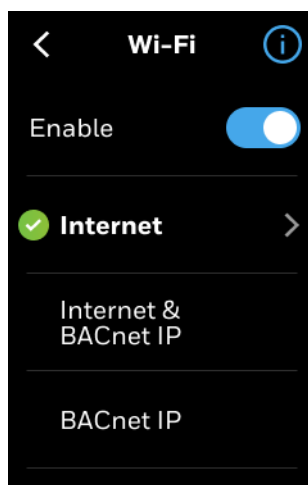

5. Tap **Internet**, to set the Internet configuration.
The Internet page appears where you can configure the DHCP and Static IP configuration.

Figure 114 Internet configuration

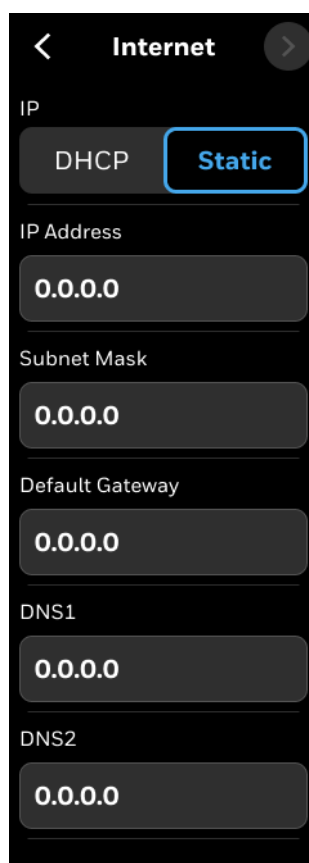

6. Either select **DHCP** or **Static**.
7. If Static is selected, then set up the given network parameters of the thermostat. This will be used to connect with the Wi-Fi network.

8. After required parameters are set, tap the right arrow button on the top of the page.
The Wi-Fi scans the network followed by displaying a list of available Wi-Fi in your premises.

Figure 115 Wi-Fi list

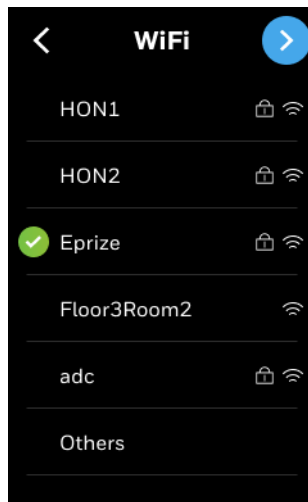

9. Tap a Wi-Fi to which you want to connect your thermostat.
10. Enter the SSID password.
11. Tap **Join**.
The Successful message appears.

To connect thermostat via BACnet IP

1. Swipe left from the Home screen.
2. On the Quick access screen, tap  > **Connection**.
The Connection screen appears.

Figure 116 BACnet MS/TP connection



3. Tap the **Wi-Fi**.
4. Enable Wi-Fi.
The Wi-Fi page appears.

Figure 117 Wi-Fi BACnet IP

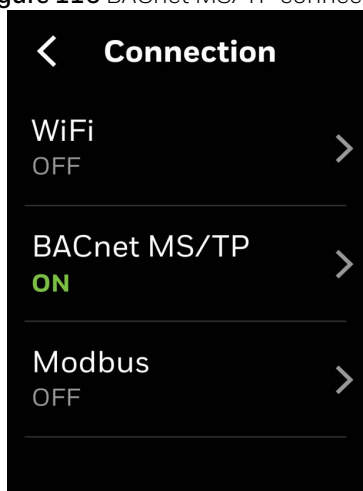
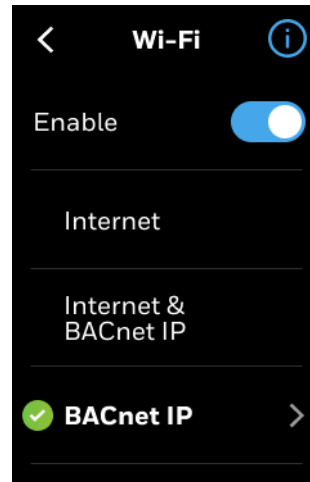

5. Tap **BACnet IP**, to connect to BACnet IP.
The BACnet IP page appears.

Figure 118 BACnet IP

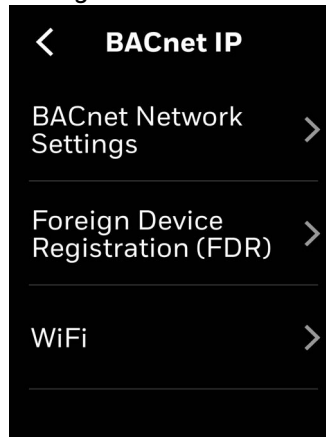

6. Tap **BACnet Network Settings**.

Figure 119 BACnet IP network settings



7. **Device ID** is a unique identifier for a BACnet device on a network. Enter a number within the given range.

8. **Network Number** is a numeric identifier for a BACnet network that allows devices to communicate across different subnets or media types. Enter a number between 1 to 65534 to assign as a unique network identifier for routing and addressing purposes
9. **UDP Port** number is a numeric identifier for a UDP communication endpoint. Enter a number to assign as a UDP port number to use for UDP protocol communication.
10. Navigate back to the BACnet settings page.
11. Tap **Wi-Fi**.

Figure 120 Internet configuration

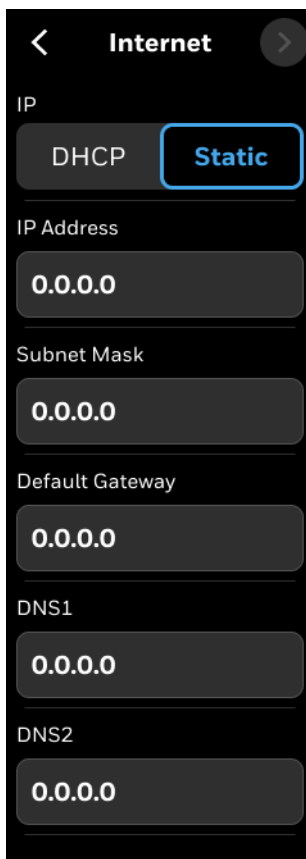

12. Either select **DHCP** or **Static**.
13. If **Static** is selected, then set up the given network parameters of the thermostat. This will be used to connect with the Wi-Fi network.
14. After required parameters are set, tap the right arrow button on the top of the page. The Wi-Fi scans the network followed by displaying a list of available Wi-Fi in your premises.

To connect thermostat via Internet & BACnet IP

1. Swipe left from the Home screen.
2. On the Quick access screen, tap  > **Connection**.
The Connection screen appears.

Figure 121 BACnet MS/TP connection



3. Tap the **Wi-Fi**.
4. Enable Wi-Fi.
The Wi-Fi page appears.

Figure 122 Internet IP & BACnet.

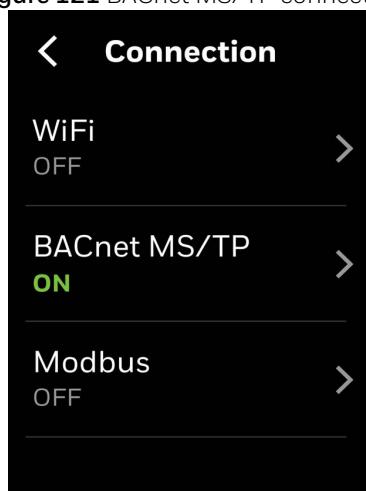
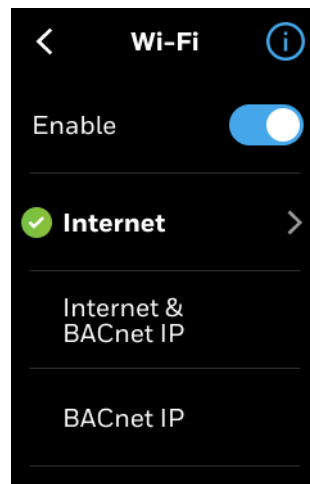

5. Tap **Internet & BACnet IP**, to connect to both Internet and BACnet IP.
The BACnet IP page appears.

Figure 123 BACnet IP

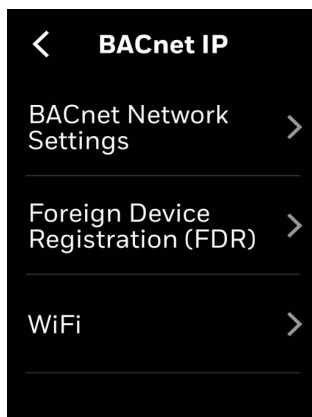

6. Tap **BACnet Network Settings**.

Figure 124 BACnet IP network settings



7. **Device ID** is a unique identifier for a BACnet device on a network. Enter a number within the given range.
8. **Network Number** is a numeric identifier for a BACnet network that allows devices to communicate across different subnets or media types. Enter a number between 1 to 65534 to assign as a unique network identifier for routing and addressing purposes.
9. **UDP Port** number is a numeric identifier for a UDP communication endpoint. Enter a number to assign as a UDP port number to use for UDP protocol communication.
10. Navigate back to the BACnet settings page.
11. Tap **Wi-Fi**.

Figure 125 Internet configuration

The screenshot shows a mobile application interface for configuring internet settings. At the top, there is a title bar with a left arrow, the word "Internet", and a right arrow. Below this, there are two buttons: "DHCP" and "Static". The "Static" button is highlighted with a blue border, indicating it is the selected option. Underneath, there are five input fields, each with a label and a value of "0.0.0.0": "IP Address", "Subnet Mask", "Default Gateway", "DNS1", and "DNS2".

12. Either select **DHCP** or **Static**.
13. If Static is selected, then set up the given network parameters of the thermostat. This will be used to connect with the Wi-Fi network.
14. After required parameters are set, tap the right arrow button on the top of the page. The Wi-Fi scans the network followed by displaying a list of available Wi-Fi in your premises.

To connect thermostat via BACnet MS/TP

1. Swipe left from the Home screen.
2. On the Quick access screen, tap  > **Connection**.
The Connection screen appears.

Figure 126 BACnet MS/TP connection



3. Tap the **BACnet MS/TP**.
The BACnet MS/TP screen appears.

Figure 127 BACnet MS/TP

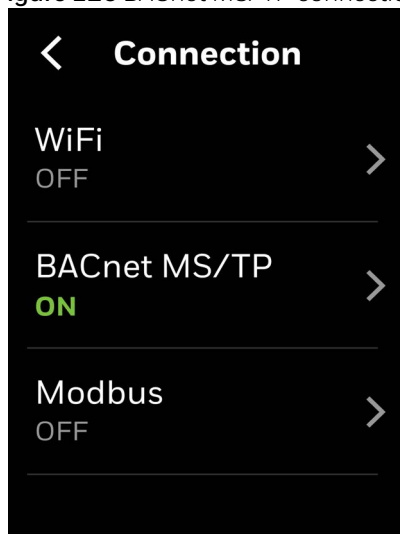
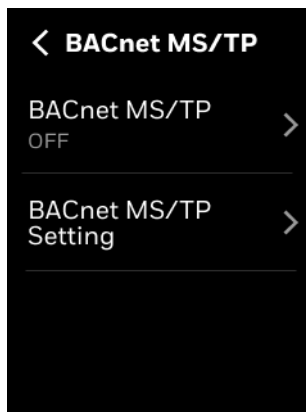

4. Tap **BACnet MS/TP** and enable it.
The **Disable BACnet IP** caution message appears.
5. Read the message and tap **Yes** to continue.
The BACnet MS/TP range screen appears.

Figure 128 BACnet MS/TP

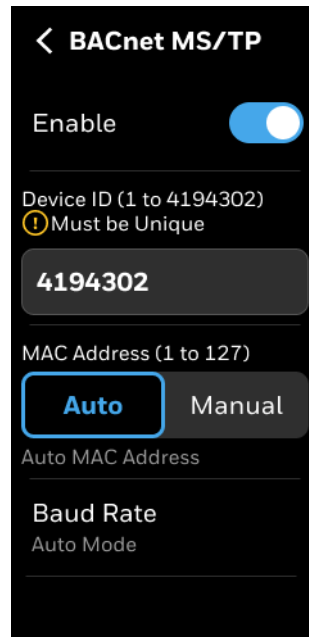

6. The device automatically adapts to the baud rate of the MS/TP network. You can also manually select the Baudrate
7. Enter a unique Device ID for the thermostat. It should be different from other TC300 thermostats.
8. Auto-MAC addressing is enabled by default, Installer can also manually set a unique MAC address for the TC300 thermostats.

Note: *The baud rate can be manually configured only after initial 5 minute delay.*

9. To do manual configuration, tap **Manual**.
A text box appears below to enter the manual MAC address.
10. Tap **Baud Rate**, to select a desired baud rate from the list.

Figure 129 Baud Rate

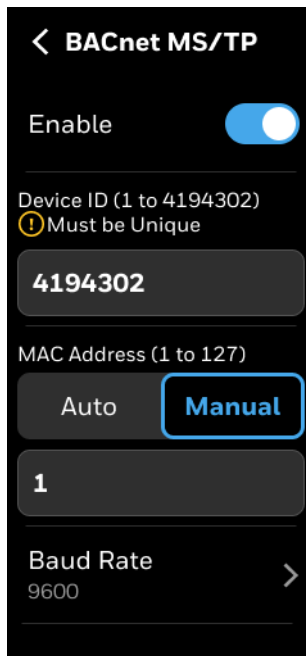

11. Tap the back arrow button to navigate back to BACnet MS/TP setting screen.
12. Tap **BACnet MS/TP Setting**.
The BACnet MS/TP setting screen appears.

Figure 130 BACnet MS/TP Setting

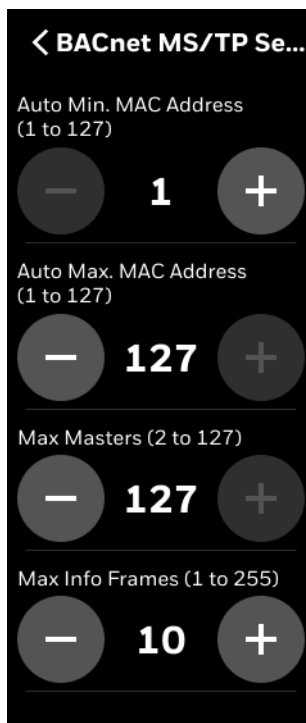

13. Set the desired parameters and tap the back arrow button to navigate back to the connection screen.

TC300 thermostats will try to adapt to the Baudrate of the MS/TP network in the first 4 minutes after startup or MS/TP is enabled. If no Baudrate could be determined, for example, there is a single device on the network, then TC300 thermostats will choose the default Baudrate of 76800. After that, the Installer can manually change it to another value.

To connect thermostat via Modbus

1. On the Connection screen, tap **Modbus** and enable it.
The Modbus setting screen appears.

Figure 131 Modbus

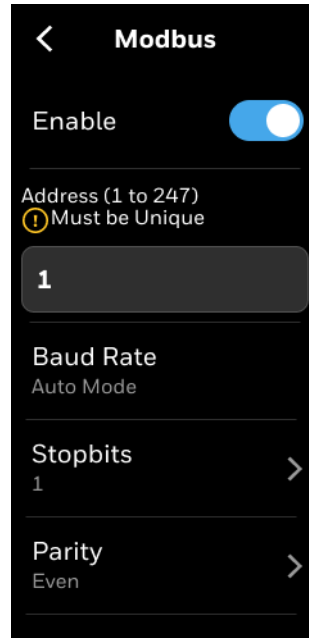

2. Enter a unique address for the thermostat. It should be different from other TC300 thermostats.
3. Set the Baud Rate, Stopbits, and Parity from the list.
4. Tap the back arrow button to navigate back to the connection screen.

To configure Foreign Device Registration (FDR)

1. Swipe left from the Home screen.
2. On the Quick access screen, tap  > **Connection** > **Wifi**
Enable by sliding the toggle switch to right.

Figure 132 Wifi



3. Select **BACnet IP** > **Foreign Device Registration (FDR)**

Figure 133 FDR Settings

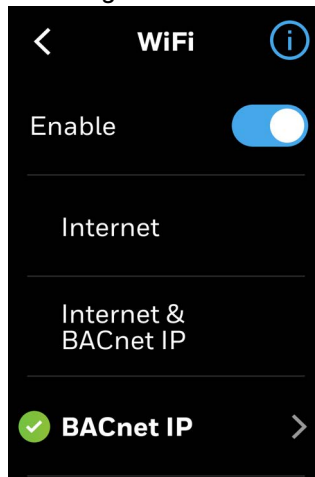
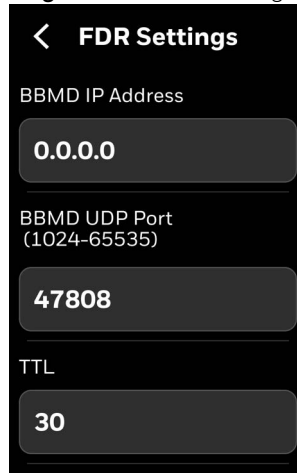

Mobile App Connection

Mobile App Connection is a feature that allows the thermostat to connect to the Forge cloud and access the cloud features and services.

To enable the Mobile App Connection

1. Swipe left from the Home screen.
2. On the Quick access screen, tap  > **Configuration**.
The Configuration screen appears.
Tap **Mobile App Connection**

Figure 134 Configuration



3. **Mobile App Connection** have two options Contractor Mobile App and User Mobile App.

Figure 135 Mobile App Connection

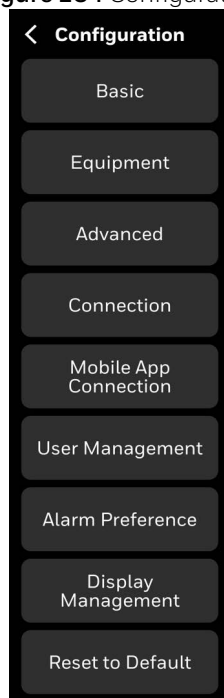
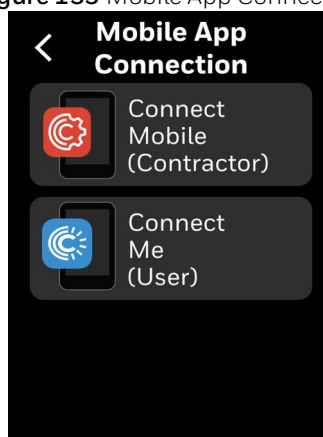

4. Tap Connect Me (User).

Figure 136 User App

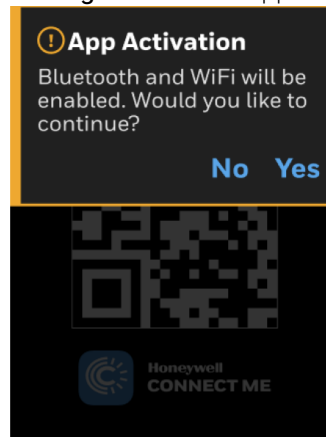

5. The Mobile App Connection caution message appears if Bluetooth and Wi-Fi are disabled.
Tap **Yes** to continue.
The Bluetooth scan QR code appears.

Figure 137 Bluetooth scan code for mobile app



6. Install the Honeywell CONNECT ME mobile app. Refer to [Integrating with occupant app and cloud registration](#).
7. Open the mobile app, scan the QR code to connect with the mobile app.
While connecting to app, the Wi-Fi connection, Cloud registration, and Cloud connection happens sequentially.

Figure 138 Cloud connection

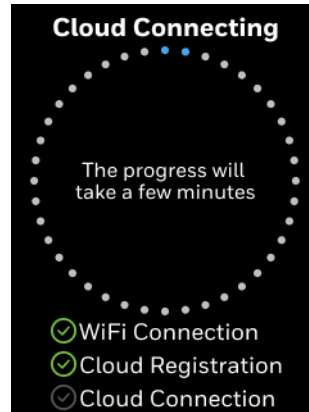

After successful connection, the Cloud Connection Successful! message appears.

Figure 139 Cloud connection successful

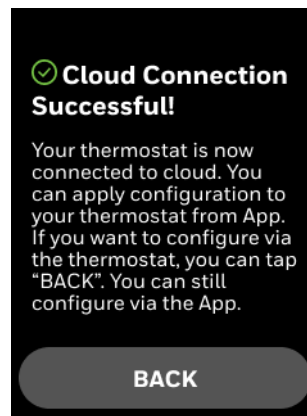

For Contractor App

1. From Mobile App Connection, select Contractor App. Contractor App QR scan appears

Figure 140 Contractor App

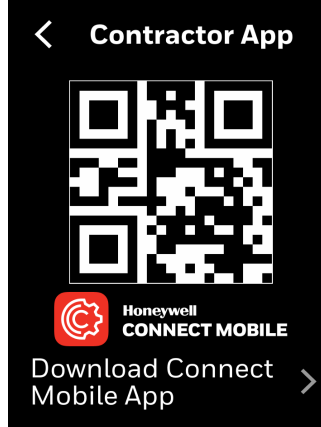

2. Install the Honeywell CONNECT ME mobile app. Refer to [Integrating with occupant app and cloud registration](#).

Figure 141 Connected with Connect Mobile



Integrating with occupant app and cloud registration

Authorized users may remotely monitor and control thermostats using the Connect Me app. Administrators may also use app to manage sites and users. This mobile app integration also helps to register the thermostat with the Cloud network and subsequently supports Over-The-air (OTA) firmware upgrade.

Prerequisites

- Go to the app store and search for “Honeywell Connect Me” to download the app. or, scan the QR code given below. Install the app on your mobile device, then create an account, and create a site.



To integrate with the Occupant app and Cloud registration

1. Turn on Bluetooth on the thermostat. Refer to [Bluetooth](#).
2. On the Occupant app, after app registration and site creation, you will be prompted to add a thermostat.

The following page appears.

Figure 142 Occupant app - Adding thermostat

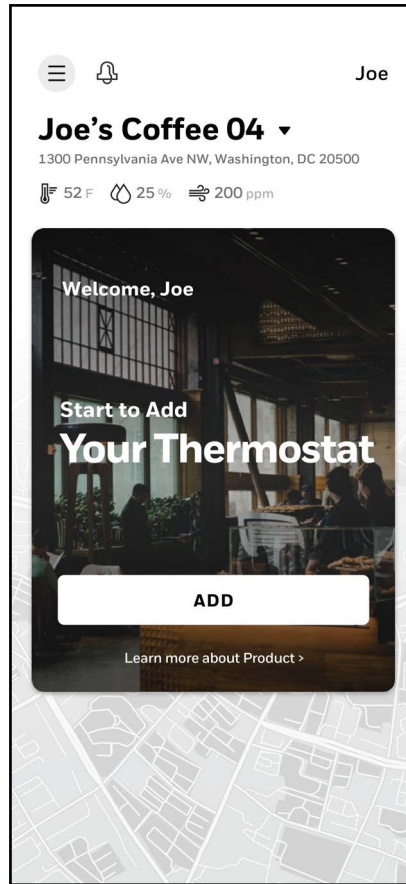

3. Select **Add**.
4. Select **SCAN TO CONNECT**.
5. Scan the QR code that appears on the thermostat Bluetooth page.

Figure 143 Thermostat - Bluetooth page

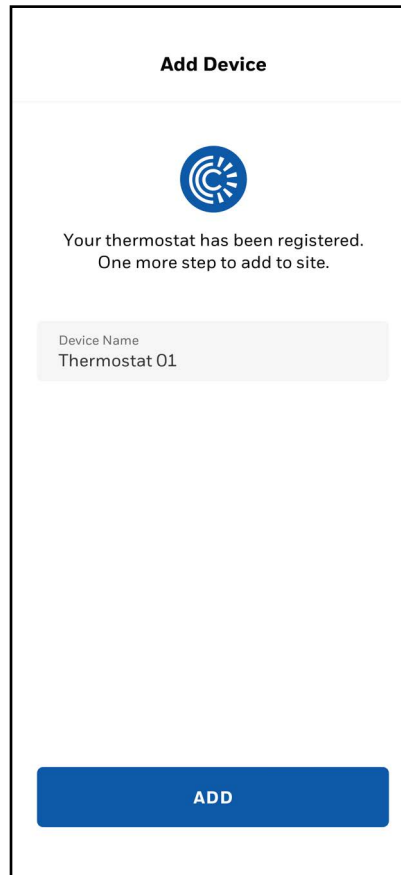

6. The **Successfully Connected** message appears on the Occupant app if connected successfully.
Subsequently, the thermostat will be registered to the cloud and registration message appears. Then, the Add Device page appears.

Figure 144 Add Device - Naming thermostat

7. You can rename the device name, then select **ADD**. This will update the thermostat name in the actual thermostat itself.
If the thermostat name is renamed then the Updated thermostat name appears.
After a successful connection, the "Your thermostat is added and ready to use" message appears.

Figure 145 Thermostat is added to the Occupant app

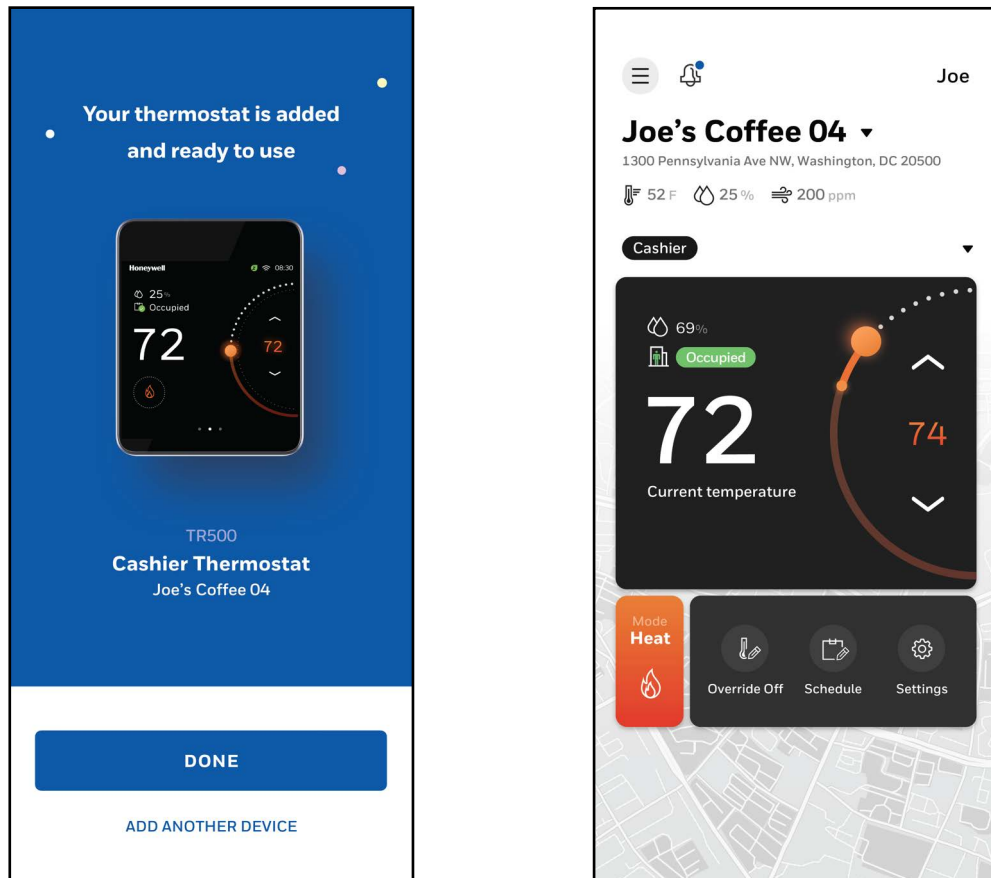

8. Select **DONE**.
Registered thermostat home page appears on your mobile.
To remove the registration, refer to [Home page \(Display Management\)](#).

User management

The TC300 thermostats support four kinds of user identities as identified in Table 34 with limited privileges as noted. Except for the Installer role these privileges can be reduced in the user settings menu.

Table 34: User roles and permissions

	Visitor	Basic User	Admin	Installer
System Mode		✓	✓	✓
Override		✓	✓	✓
View Alarm		✓	✓	✓
Temperature Units		✓	✓	✓
Fan Speed Configuration		✓	✓	✓
Brightness		✓	✓	✓
Schedule			✓	✓
Setpoint			✓	✓
Basic Configuration			✓	✓
Advanced Configuration				✓
Equipment				✓
Wifi			✓	✓
language			✓	✓

Passcode rules

All the user accounts are passcode protected. When creating the passcode, follow the passcode rules given below.

- Passcode length must be between 4 to 12 characters
- Do not use spaces
- Do not use the same passcode used for other users (across all user types)
- If no passcode is entered for basic or Admin, the thermostat will remain at the highest level of access, installer, and will not require a passcode for access.

User roles

To configure user management

1. Swipe left from the Home screen.
2. On the Quick access screen, tap  > **User Management**.
The User Management screen appears.

Figure 146 User management



3. Tap the help icon to view the access limitation of each user role.

Visitor

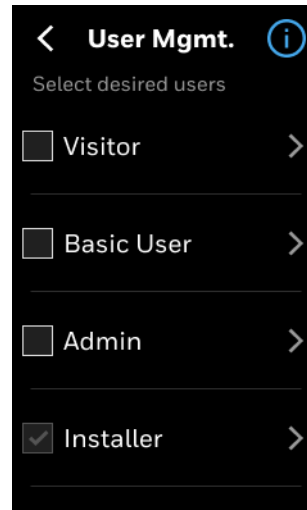
To view the Visitor user role

1. On the User Management screen, select **Visitor**.
2. Tap  to go to the previous screen.

Basic user

To manage the Basic User role

1. On the User Management screen, select **Basic User**, and tap .
The Basic User screen appears.
2. Set a passcode and user permission. The passcode will be used by the user to access the thermostat. Refer to [Passcode rules](#).

Note: The *Passcode* button appears only if the pass is set for the Basic user.

Figure 147 Basic user

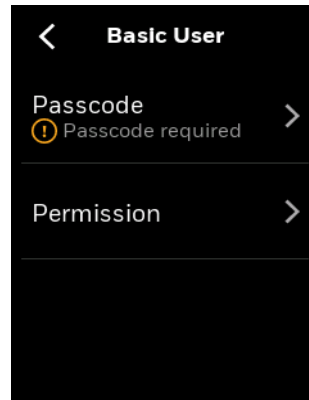

3. Tap **Permission**.
The Permission screen appears.

Figure 148 Basic user permission.

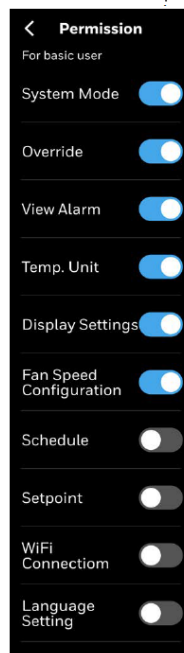

4. Toggle the undesired Permissions to "Off" position.

Admin

To manage the Admin role

1. On the User Management screen, select **Admin**, and tap .
The Admin User screen appears.
2. Set a passcode and user permission. The passcode will be used by the Admin user to access the thermostat. Refer to [Passcode rules](#).

Figure 149 Admin user



3. Tap **Permission**.
The Permission screen appears.

Figure 150 Admin user permission.

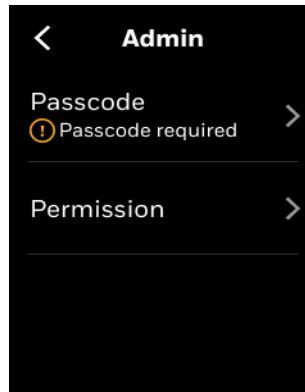
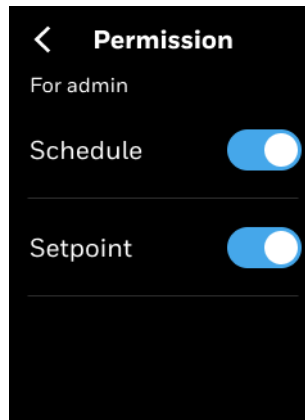

4. Toggle the undesired Permissions to “Off” position.

Installer

To manage the Installer role

1. On the User Management screen, select **Installer**, and tap .
2. Set or change a Passcode. Refer to [Passcode rules](#).

Figure 151 Installer



Home screen (Display management)

This section explains managing the icons displayed on the Home screen and Ambiance screen of thermostat. It is applicable at the device level so any changes on the display management will be applied to all user accounts.

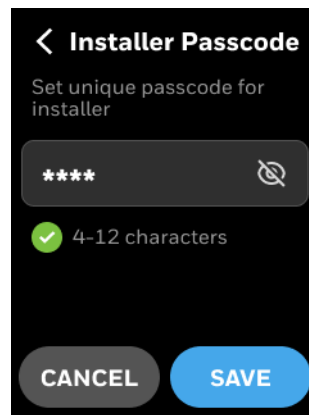
To configure the home screen

1. Swipe left from the Home screen.
2. On the Quick access screen, tap  > **Display Management**.
The Display Management screen appears.

Figure 152 Display management



All icons are enabled by default. You can turn it off by sliding the toggle button to the left.

3. Tap **Branding** to select a brand name that will be displayed on the home screen.
4. Scroll down to see more options.

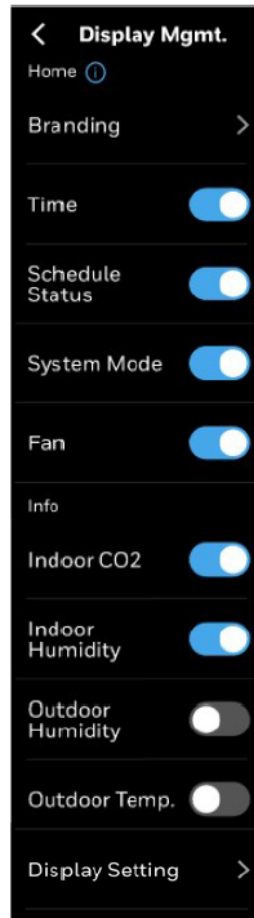
Note: Tap the information icon to view the icon names.

Display settings

Display settings of the thermostat includes increasing/reducing display brightness and settings to off the display, dim the display, or show only ring when the display is on sleep mode.

To manage display settings

1. Swipe left from the Home screen.

Figure 153 Quick access screen

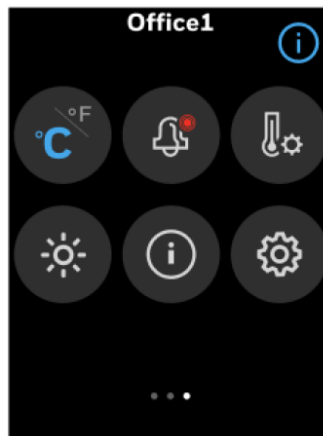

2. Tap **Display Setting**
The Management Settings screen appears.

Figure 154 Display settings

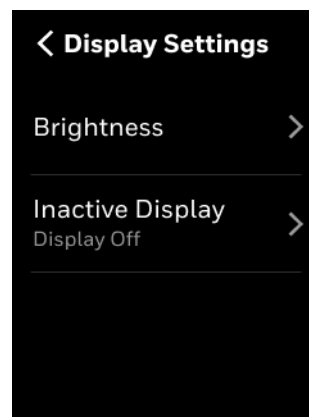

3. Tap **Brightness**.
The Brightness screen appears.

Figure 155 Brightness

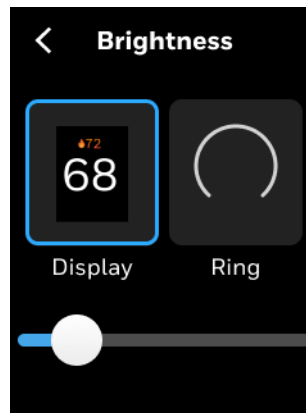

4. Tap Display and move the slider to right to increase the brightness of the display.
5. Tap Ring and move the slider to the right to increase the brightness of the ring.
6. Navigate back to the Display settings screen to configure Inactive display.
7. Tap **Inactive Display**.

The Inactive Display screen appears.

The inactive display is when there is no user action on the display. User either can set the display always on or always off.

Figure 156 Inactive display



8. Tap **Display Off** to set the display off. However, the ring LED breaths to show the system mode. Or, tap **Always On** to show both display and ring LED. Or, tap **Always Off** to keep both ring LED and display off.

Reset to default

User can reset the entire thermostat to the factory default or reset only temperature setpoints and schedule to factory default.

To reset the factory default setting

1. Swipe left from the Home screen.
2. On the Quick access screen, tap  > **Reset to default**.
The Reset to Default screen appears.

Figure 157 Reset to default



3. Tap **Reset Weekly Schedule & Setpoint** to only reset the temperature and schedule setpoint. It retains other configurations.
4. Tap **Reset All** to fully reset the thermostat. It deletes all the configurations and user data.
5. Tap **Clear BLE PIN Code** to clear the Bluetooth PIN. After reset, the existing PIN become invalid. Go to Honeywell Connect Mobile or Honeywell Connect Me app to create BLE PIN CODE.
6. Tap **Reset Registration** to clear the registration files. The device will restart.
7. Tap **Restart Device** to restart the device without deleting any data.

Figure 158 Weekly reset and confirmation message

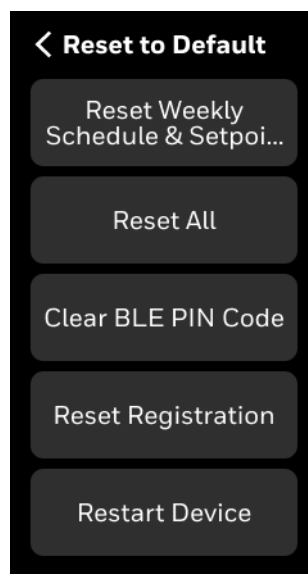
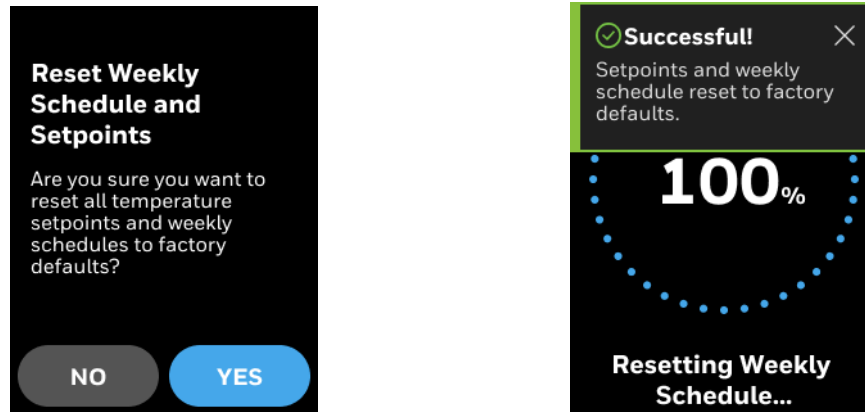

8. Upon successful reset, user will be notified by a notification banner.

System status

The system status shows device information, live status and readings of the sensors that are operated or connected with the thermostat. These values are view only.

To view system status

1. Swipe left from the Home screen.

Figure 159 Quick access screen

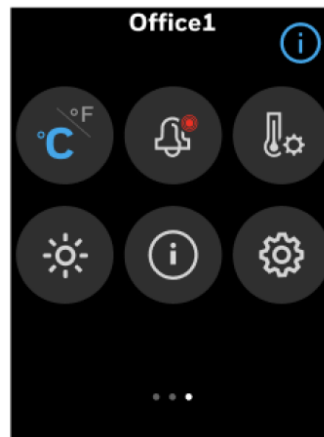

2. On the Quick access screen, tap .
The System status screen appears.

Figure 160 System status

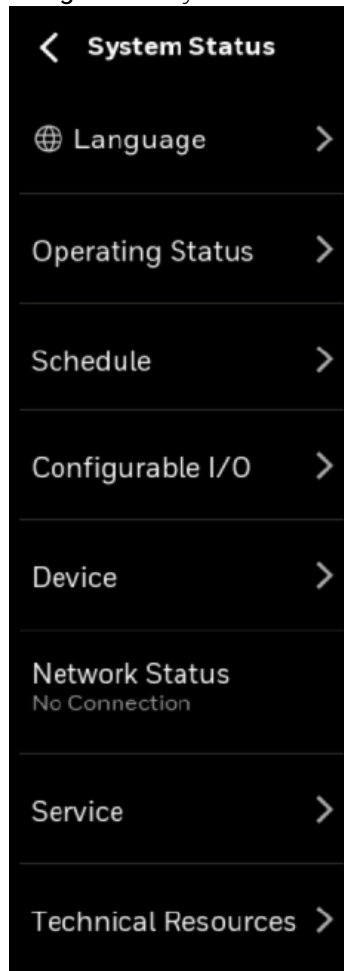



Table 35: System status

Displays Language settings	total five languages are available English, Spanish, French, Italian, and German
Operating status	Equipment type, Current operating mode, Heat status, Cool status, Aux heat, Fan status, Indoor temperature, Outside temperature, Indoor setpoint, Indoor humidity, Indoor CO2, Discharge air temperature, Discharge air control setpoint, Pipe temperature, Recovery status, Override remaining, Run time, Restart reason, Terminal load, UTC offset
Schedule	Current schedule time, Current occupancy state, Current schedule state, Next schedule state, Time to next schedule state,
Configurable I/O	All terminals ON/OFF status.
Device	Model name, Boot loader version, Firmware version, Application version, UUID, Serial No.
Network status	For BACnet MS/TP: Device ID, MAC address, Baud rate. For Modbus: Address, Baud rate, Parity, Stopbits. For Wi-Fi: Network, Connection Status, Wi-Fi MAC Address, Wi-Fi SSD, Wi-Fi IP Address.
Service	Service personnel name and phone number.

Table 35: System status

<p>Technical Resource</p>	<p>Displays a QR code. Scan it using mobile camera to access the technical literature.</p> 
---------------------------	---

Setpoints

To configure setpoint settings

1. Swipe left from the Home screen.

Figure 161 Quick access screen

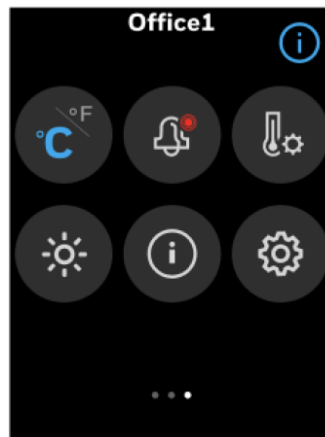

2. On the Quick access screen, tap . The Setpoint screen appears.

Figure 162 Define the setpoints



- On the **Setpoints** screen, tap **Occupied**, **Standby**, or **Unoccupied**
The Occupied screen appears.

Figure 163 Occupied

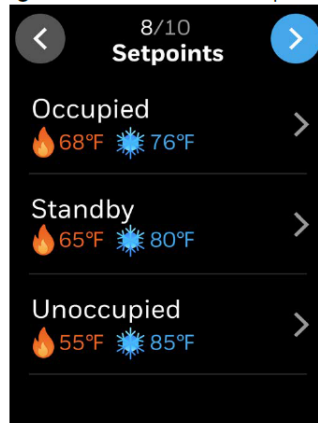
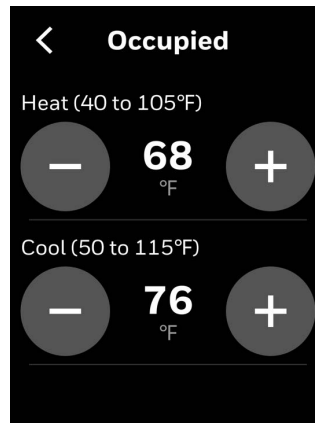

Tip: Long press the +/- button to quickly increase or decrease the value.

- Configure the required setpoint limits for Occupied, Standby, and Unoccupied modes. Thermostat performs limit checking on all temperature setpoints, in case setpoint relationships are violated.
 - Occupied mode treats the building space as occupied and configured with comfort setpoints.
 - Unoccupied mode treats the building space as not occupied and configured with energy savings setpoints.
 - Standby mode setpoints are configured in a way that target setpoint levels can be achieved quickly with the onset of the next occupied period.
 - Temporary mode allows the user to change the temperature setpoints of the Occupied mode after the user switches to the temporary mode from the Occupied mode. This is not possible in Unoccupied mode and Standby mode.
 - Minimum cool setpoint and maximum heat setpoint can be adjusted, default minimum cool setpoint is 50°F, maximum heat setpoint is 105°F. Heat setpoint range: 40°F-105°F; Cool setpoint range: 50°F-115°F.
 - While configuring the temperature range make sure that the unoccupied heat \leq standby heat \leq occupied heat $<$ occupied cool \leq standby cool \leq unoccupied cool.
 - Occupied cool setpoint should be at least a deadband value bigger than occupied heat setpoint.

Occupancy sensor behavior

- The occupancy sensor only affects the effective occupancy when the scheduled occupancy state is Occupied:
- When occupancy sensor state is occupied, the effective occupancy will act as occupied.

Figure 164 Occupancy Sensor Delay

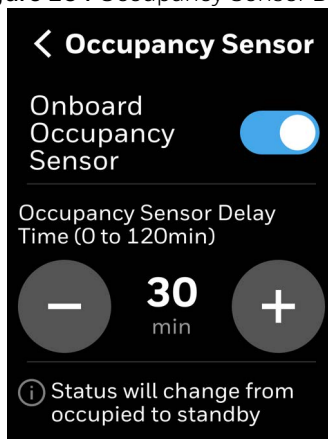

- When the occupied sensor status is unoccupied throughout delay time period, the effective occupancy will change to standby.
- When the scheduled occupancy state is unoccupied or standby, the effective occupancy will follow scheduled occupancy state, will ignore the occupancy sensor's value.
- For models with an on-board occupancy sensor (TC3x2/TC3x3), users can configure whether to enable the occupancy sensor. By default, it is enabled.

System mode

To change the system mode

1. On the Home screen, tap mode icon, for example . The Mode screen appears.

Figure 165 System mode



2. Select a mode and tap the back arrow button. The mode is changed.

Fan speed

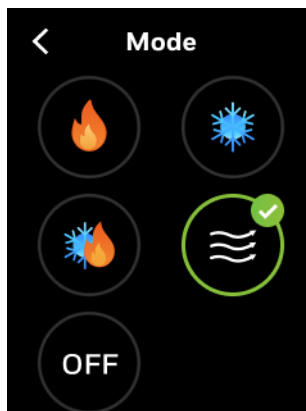
To change the fan speed

1. On the Home screen, tap mode icon.
The Fan Speed screen appears.

Figure 166 Fan speed

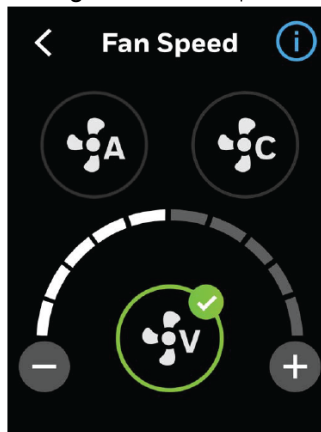

2. Select a fan speed and tap the back arrow button.
The fan speed is changed.
Auto fan can be selected only during Standby or Unoccupied status.
During dehumidification, the fan speed will be limited to low speed automatically.
3. Tap the help icon to view the fan mode description.

Figure 167 Fan speed help

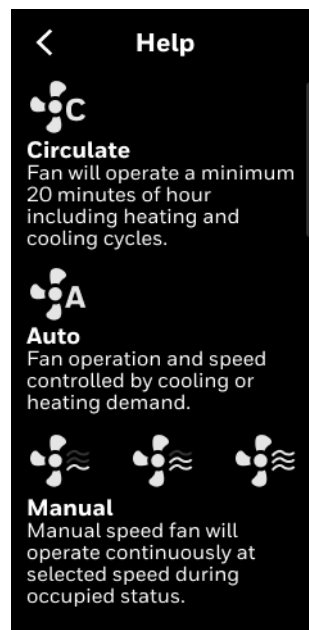

Auto firmware update

The TC300 thermostats, if connected to the Internet, automatically download and install the latest firmware version from the cloud.

Figure 168 Auto firmware update

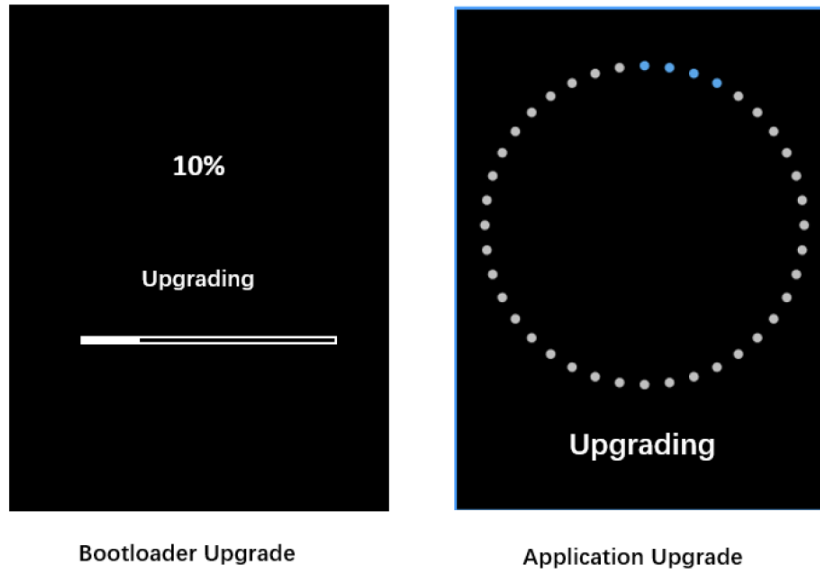

Sylk Device support TR100 as TR75

To utilize the value form Sylk Wall Module after connecting TR100 emulating TR75 to the Sylk address 6

To add Sylk 6 Wall Module.

1. Swipe left from the Home screen.
2. On the Quick access screen, tap  > **Equipment** > **Sensor Setting** > **Sylk Sensors**.
The Sylk Sensors screen appears.
3. Select TR100 as TR75 at Sylk address 6.

Figure 169 Sylk Sensors



4. Address 6 screen appears.
Enable it by sliding the toggle button to left and choose the Humidity.

Figure 170 Adr.6

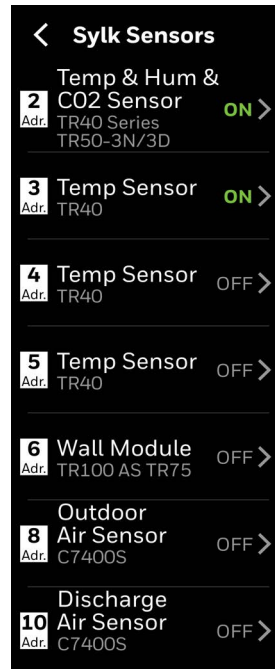
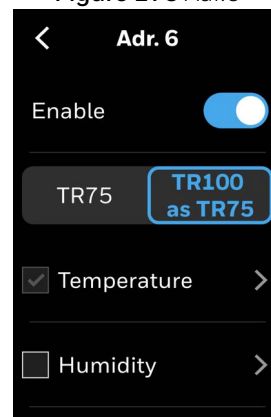

TC300 Support Wall Module "TR100 Using TR75 Emulation" on Sylk Addr.6 Limitations

System Mode

TC300:

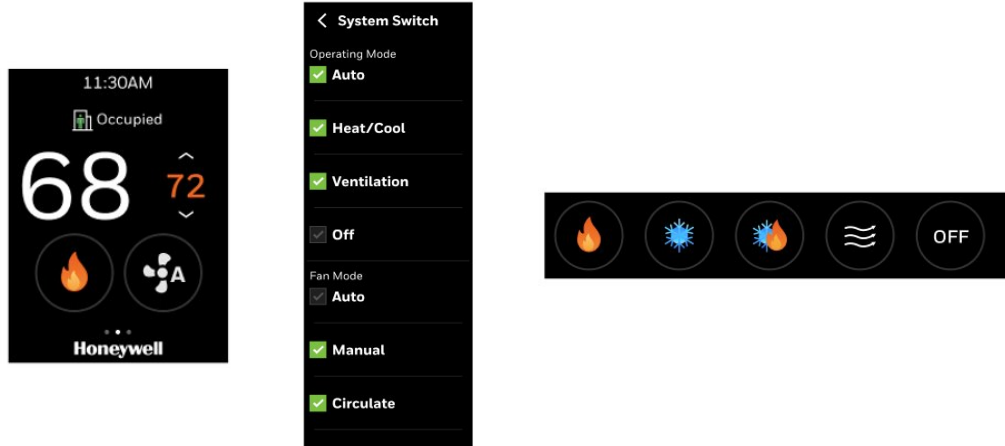

TR100 doesn't have Fan Only mode, if TC300 change to Fan Only, TC300 configure successful, TR100 remain unchanged.

TR100 Using TR75 Emulation

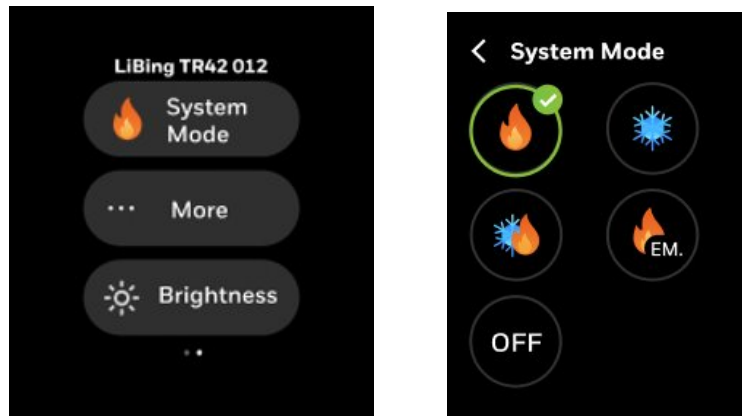

If TR100 change to some mode TC300 don't support, for example: heat only equipment, but TR100 change to cool mode. TC300 will remain unchanged. Then, TR100 Set unsuccessful, TR100 fall back to last mode.

Fan Speed

TC300

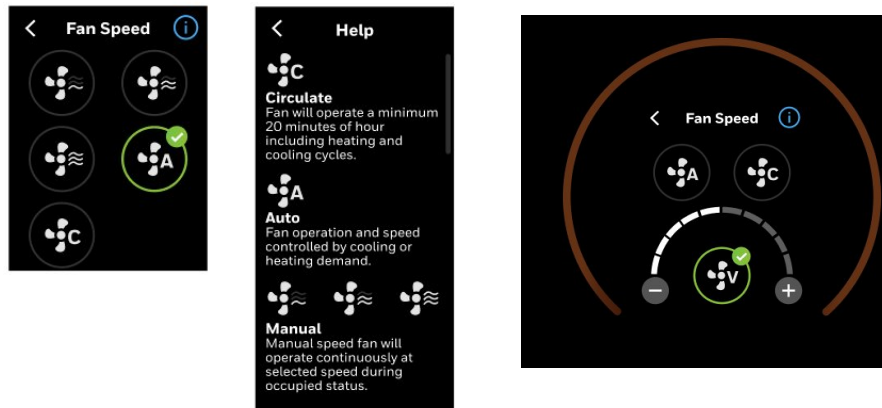

TR100 has No Circulate, No Variable,

If TC300 change to Circulate and Variable, TC300 configure successful, TR100 will remain unchanged. Yes

TR100 Using TR75 Emulation:

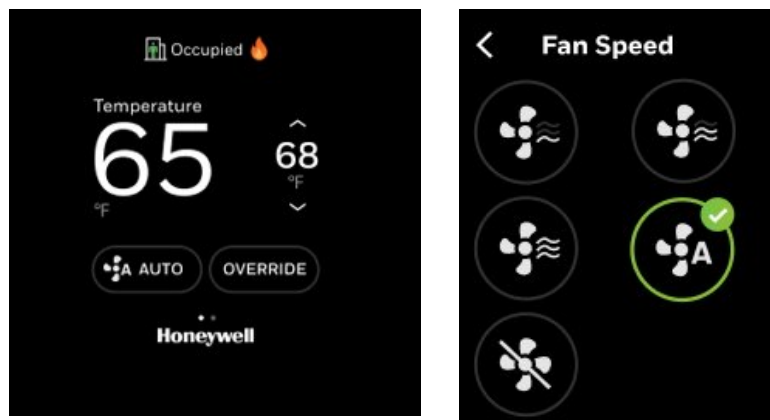

TC300 doesn't have Fan Off. If TR100 configure to fan speed which TC300 doesn't support, for example Fan Off or TR100 set 3-speed but TC300 only has 2-speed fan. TC300 will remain unchanged. Then, TR100 Set unsuccessful, TR100 fall back to last mode.

Override

TC300:

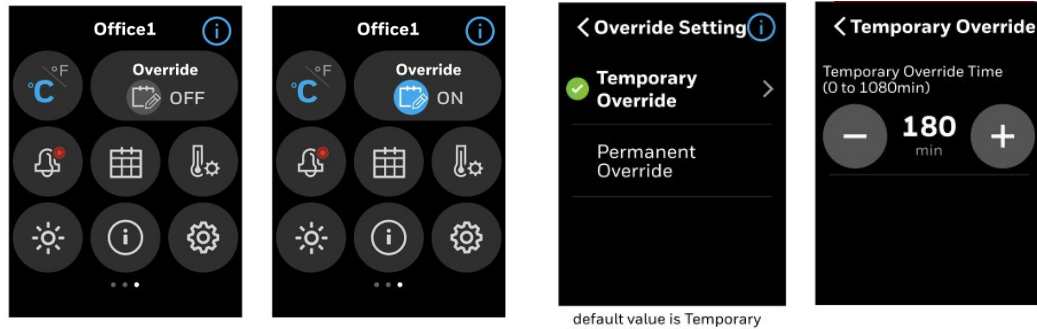

If temporary override, TC300's Temporary override can be synchronized to TR100 as TR75 (Bypass timer)

If permanent override, TR100 cannot support permanent override. TC300 will send Bypass timer with a very large value to TR100 as TR75.

TR100 Using TR75 Emulation:

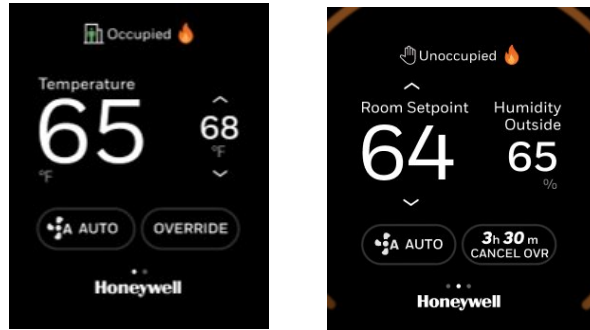

Enable/disable Override from TR100-> can sync to TC300

Enable/disable Override from TC300-> cannot sync to TR100

During override, TC300 switch schedule type to others, TC300 override canceled but TR100 still Override On

Schedule (Commercial)

TC300:

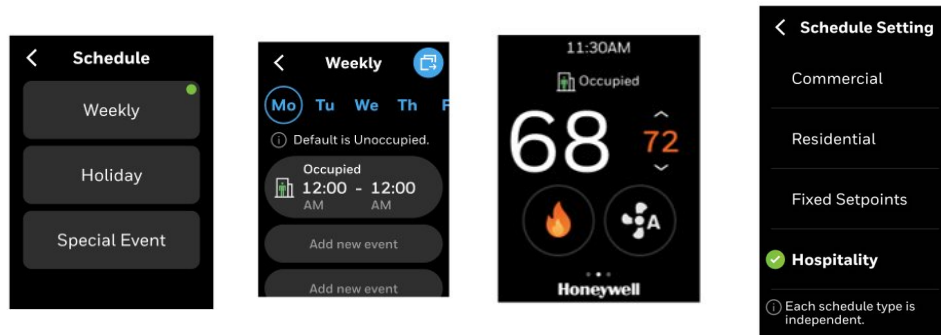

If TC300 is in commercial schedule, schedule will be synchronized between TC300 and TR100.

If TC300 is configured with residential schedule or in fixed setpoint mode, the setpoint will be synchronized with TR100, but the schedule will be empty.

TR100 Using TR75 Emulation:

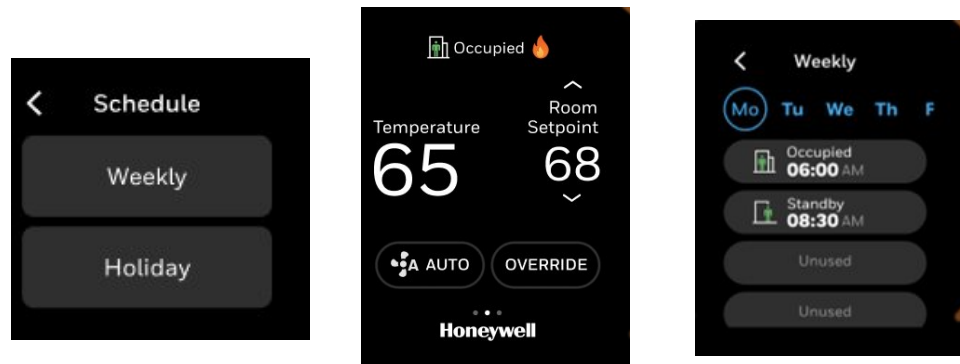

If TC300 is not in commercial schedule, TR100 still show commercial schedule. when user configure schedule from TR100 HMI, this newly configured schedule cannot be sync to TC300, TR100 schedule show. when next time TC300 change to commercial schedule, will be synchronized from TR100.

TR100 supports Contractor mode whereby contractor can configure display appearance using "More" menu accessed by long-press of Honeywell brand logo.

TC300 Using Hospitality Mode

Note: TR100 is incompatible with TC300 when using hospitality mode.

Including:

when TC300 is in ADR mode, or Ventilation mode, or Off mode, TR100 cannot change setpoint when TC300 is in Fixed Setpoint mode. It may only initiate temporary override.

After restoring to the scenario where synchronization is possible, once either of them has configuration changes, the new configuration will be synchronized normally.

Auto Demand Response

To Configure Response Demand

1. Swipe left from the Home screen.
2. On the Quick access screen, tap  > **Auto Demand Response** > **ADR**.
The ADR Sensors screen appears.
3. Enable ADR by sliding the toggle button to left.

Figure 171 ADR



4. Tap the help icon to view the ADR help information.

Figure 172 ADR Help Information

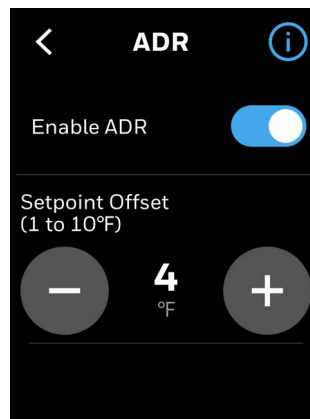
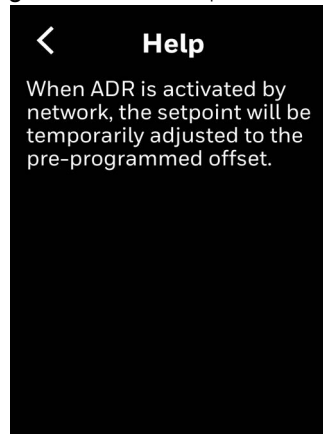

This chapter explains alarms and their configuration procedures.

Related topics

[Alarms](#)

[Alarm notification signs](#)

[Alarm notification](#)

[Alarm preference](#)

[Unacknowledged alarms](#)

[List of alarms and their severity](#)

[Managing the alarms](#)



Alarms

In the TC300 thermostats, alarms are configured for predefined set values. When the values are breached, the alarms are triggered and displayed on the home screen as banner notification, dot notification, and on the Alarm button. You can view the triggered alarms and acknowledge them.

Alarm notification signs

The alarm menu notification icon has two color codes to indicate the severity of the alarm. The following table describes the available signs with color codes of the alarm screens.

Alarm notification

Icons	Description
	High
	Medium

The alarms can be configured as banner notification or dot notification as per the alarm configuration. The banner notification is pop-up on the home screen whereas the dot notification appears beside the time. For alarm configuration, refer to [Alarm preference](#).

Figure 173 Alarm banner notification

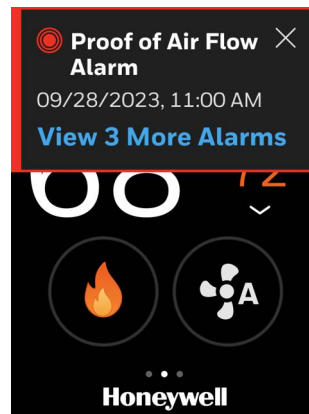

You can tap the banner notification to view the alarm and acknowledge it. If multiple alarms are triggered then the latest one (high) will be displayed on the home screen. After tapping the banner, it takes you to the **Alarm** screen.

- High - Red color banner
- Medium - Orange color banner

Alarm preference

Alarm preference is a feature that allows the user to configure the alarm priority and behavior for different types of alarms on the device.

To create alarm preference

1. Swipe left from the Home screen.
2. On the Quick access screen, tap  > **Alarm Preference**.
The Alarm preference screen appears.

Figure 174 Alarm preference



3. Tap **Alarm**.
A list of alarm types appears.

Figure 175 Alarm types

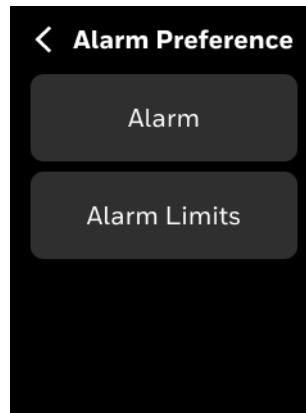
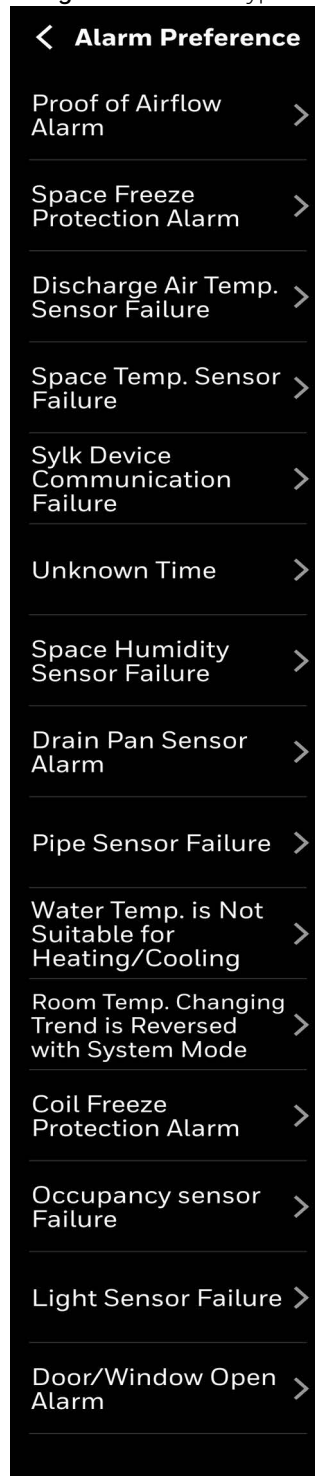

4. Tap an alarm type, for example, Proof of air flow alarm. The configuration screen of the alarm type appears.

Figure 176 Alarm configuration screen

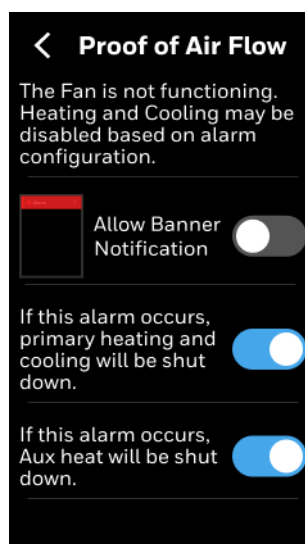

The description of the alarm reason is displayed on the screen. You can select the banner notification for this alarm if required.

In addition, option to enable banner notification and couple of follow-up actions are provided that will triggered when alarm occurs based on the user selection. These follow-up actions vary depending on the type of alarm.

5. Toggle the **Allow Banner Notification** to on to get the banner notification of the this type of alarm on the home screen.

Note: *Dot notification of alarm is default. The dot will appear on Alarm bell icon on the home screen and Configuration screen.*

6. Toggle the follow up actions such primary heating and cooling shutdown, and Aux heat shutdown for this alarm if required.

To configure alarm limits

Alarm limits are the settings that determine when an alarm is triggered on the device. For example, the shutdown alarm sensor can be configured to be normally open or normally closed, and the space temperature sensor can have different alarm priorities and actions.

1. On the **Alarm Preference** screen, tap **Alarm Limits**.
The Alarm Limits screen appears.

Figure 177 Alarm limits

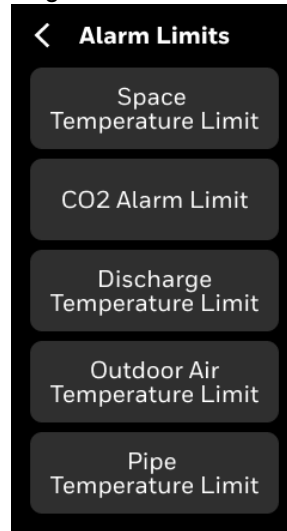

2. Tap **Space Temperature Limits** to set the limits for space temperature, when its break, alarm will be raised.
3. Tap **CO2 Alarm Limit** to set the limit for CO2 Alarm, When the CO2 concentration rises above the CO2 alarm limit, Space CO2 limit exceeded alarm will be triggered.
4. Tap **Discharge Temperature Limits** to set the limits for DAT, when its break, alarm will be raised.
5. Tap **Outdoor Air Temperature Limits** to set the limits for OAT, when its break, alarm will be raised.
6. Tap **Pipe Temperature Limits** to set the limits for pipe temperature, when its break, alarm will be raised.

Figure 178 Alarm limits

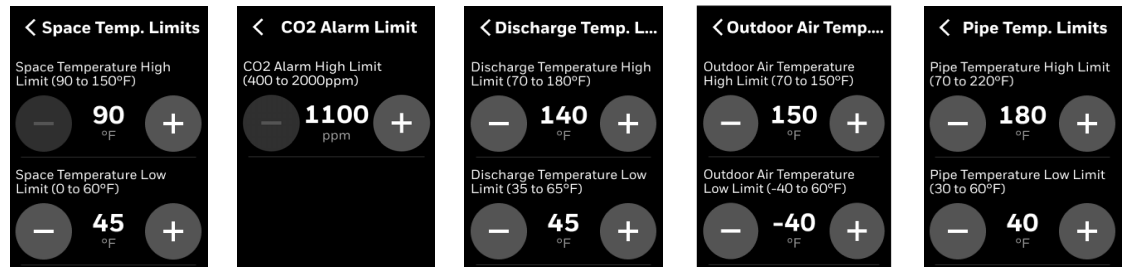

Unacknowledged alarms

In addition to the banner notification, all other alarms (for which the notification is not configured) can be viewed and acknowledged under the Alarm screen. The Alarm tab displays the alarms that have not been acknowledged by the user. If there are unacknowledged alarms, the Alarm button will have a visual dot notification as per the severity of the alarm.

To view the unacknowledged alarms

1. Swipe left from the Home screen.
2. On the Quick access screen, tap the bell (Alarm) icon.

Figure 179 Home screen - Alarm Tab

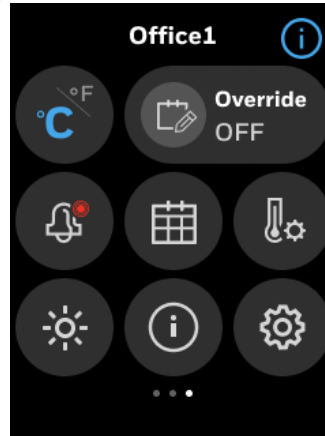

The Alarm Preference screen appears.

Figure 180 Alarm preference - Alarm

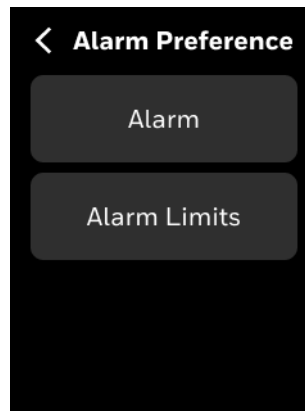

3. Tap **Alarm**.
A list of unacknowledged alarms appears.

Figure 181 Unacknowledged alarms

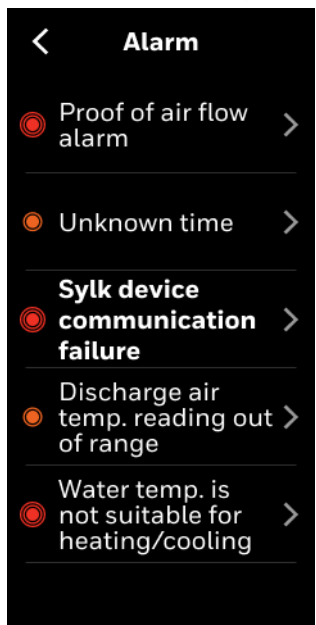

- 4. Tap an Alarm name.
The corresponding alarm property screen appears. The alarm property screen describes the nature of event state transition.

Figure 182 Alarm detail

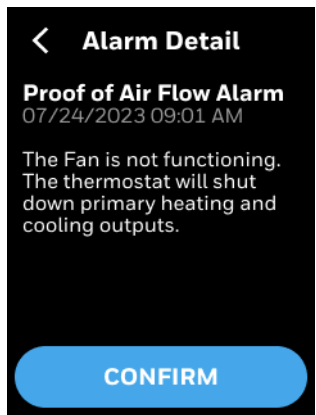

- 5. Tap **CONFIRM**.
The Alarm Detail screen appears.

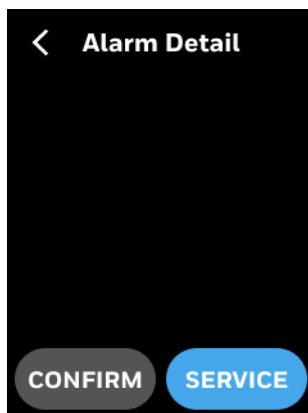
Figure 183 Alarm detail

6. Tap **SERVICE** to see the service phone number.

List of alarms and their severity

The list of alarms in the Commercial Connected thermostat is as follows.

Alarms	Severity
Proof of Air Flow Alarm	High
Space Freeze Protection Alarm	High
Space Temperature Sensor Failure	High/Medium
Space Temperature Out of Range	High/Medium
Space Humidity Sensor Failure	High/Medium
Discharge Air Temp. Sensor Failure	High
Discharge Air Temperature out of range alarm	Medium
Drain Pan Sensor Alarm	High
Sylk Device Communication Failure	High
Pipe Sensor Failure	High
Pipe Sensor Out of Range	High
Water Temperature is Not Suitable for Heating/Cooling	High
Room Temperature Changing Trend is Reversed with System Mode	High
Unknown Time	Medium
*Proof of Water Flow Alarm	High
Shutdown Alarm	High
*Heat Pump Disable Alarm	High
Outdoor Air Temp. Sensor Failure	High
Outdoor Air Temp. Out of Range	Medium
Wi-Fi Connection Lost Alarm	Low
Wi-Fi Network Not Configured Alarm	Medium
Honeywell Cloud Connection Failure Alarm	High
Cloud Connection Is Not Detected Alarm	Medium
Occupancy Sensor Failure Alarm	High
Entry Door Open Detected Alarm	High
Light Sensor Failure Alarm	High
Balcony/Window Open Detected Alarm	High
CO2 Sensor Failure Alarm	High
Space CO2 limit exceeded Alarm	Medium

Note: * This feature is applicable only to TC300B/TC320B models.

Managing the alarms

S.NO	Alarm	Trigger Scenario	Action	Level
1	Proof of Air Flow Alarm (fan state)	<p>An input (e.g., a current switch or differential pressure switch) should be available to monitor proof of air flow in the Fan Coil Unit. When configured, the control system will check this digital input once per second. If the fan is supposed to be on but is not, an alarm should be generated.</p> <p>For example, users can configure a DIO/UIO terminal as a binary input to detect the fan's status. When DIO2 is set as the Fan Command, and the device sets DIO2 to 'on,' if the digital input indicates no air flow for 60 consecutive seconds, a 'Proof of Air Flow' alarm will be triggered.</p>	<p>Depending on the alarm configuration:</p> <ol style="list-style-type: none"> 1. Display Only: An alarm will be generated, and an alarm indicator will be displayed. 2. The control system will shut down both heating and cooling outputs. The fan speed will follow the fan control logic. <ol style="list-style-type: none"> (1) The fan will remain on if there is still a call for heating or cooling. (2) In other scenarios where the fan should be on, the fan will operate based on the scheduled status: when the fan speed is set to low/medium/high, it will be on if the schedule status is 'occupied,' 'temporary,' or 'permanent.' If the fan speed is set to 'circulate,' the fan will run for at least 20 minutes per hour. 3. Upon Alarm: Dehumidification will be disabled. Both cooling and heating outputs, as well as the fan, will be turned off. 	High
2	Proof of water flow alarm (Applicable only to TC300B/TC320B models)	<p>An input (e.g., a current switch or pressure switch) should be available to monitor proof of water flow in the heat exchanger loop. When configured, the control system will check this digital input once per second.</p> <p>For example, users can configure a DIO/UIO terminal as a binary input to detect the water flow status. Set DIO2 as the proof of water flow sensor and configure the sensor as Normally Open. When there is a heating/cooling command and the water flow valve is none or open, if the digital input indicates 'Inactive' ('Active' if Normally Closed Sensor) for 120 consecutive seconds, a 'Proof of Water Flow' alarm will be triggered.</p>	<p>If a water flow alarm is detected, the compressor will be disabled.</p> <p>Depending on the alarm configuration:</p> <ol style="list-style-type: none"> 1. Display Only: An alarm will be generated, and an alarm indicator will be displayed. 2. Interlock Stage: The controller will disable the heat pump compressor and report an alarm. (The thermostat will shut down the compressor after a 120-second delay, and this function is enabled by default.) <p>Auxiliary heat will still be available. The fan will continue to operate normally.</p> <p>If there is still a call for heating/cooling, the water flow valve will remain open.</p>	High

S.NO	Alarm	Trigger Scenario	Action	Level
3	Space Freeze Protection Alarm	When the space temperature falls below 42.8°F (6°C) for more than 2 minutes, a frost alarm will be triggered. If the controller is disabled, in test mode, or in any other higher-priority mode defined by the application, the frost alarm will not be activated.	1. If the system mode is set to OFF, the freeze protection feature will activate, utilizing the effective heating setpoint, until the room temperature reaches either the heating setpoint or 8°C (46°F). 2. If the system mode isn't set to OFF, it will operate based on the standard control logic.	High
4	Sylk Device Communication Failure	If any of the Sylk sensors experience a malfunction, an alarm will be activated. This alarm will provide detailed failure information sourced from Sylk, such as 'addr10: DAT sensor malfunction'.	In case a sensor malfunctions, the thermostat will deactivate all control functions linked with that sensor, behaving as if that sensor had never been set up.	High
5	Discharge Air Temperature sensor failure	1. DAT sensor fault: An open/short limit is detected on the Discharge Air sensor (DIO1/DIO2/UIO1/UIO2). 2. DAT reading is outside of the following range (which can be set on the Alarm Limits screen): High Limit: Default 80°F (range: 70°F to 180°F) Low Limit: Default 45°F (range: 35°F to 65°F)	1. DAT sensor fault: The thermostat will deactivate all control functions related to the failed sensor, meaning it will function as though the sensor wasn't configured. 2. DAT out of range: The thermostat will not deactivate the control function. The user needs to check the equipment for correct operation.	High (failure)/ Medium (out of range)
6	Space Temperature Sensor Failure	1. When the Local Space temperature is used as the main control, a sensor fault is detected. 2. When the Remote Space temperature is used as the main control, a sensor fault is detected. 3. When multiple space temperature sensors are used as the main control, faults have been detected in one or more of these sensors. 4. When the network input space temperature value is below -40°F or above 150°F.	1. If the sensor is utilized for the control loop and network input of temperature is available, the thermostat will only trigger an alarm. 2. If the sensor is used for the control loop and the network input of temperature/humidity is not available, the thermostat will turn off all output controls for the heating and cooling equipment. The fan will continue to operate normally. 3. When the remote sensor fails, the thermostat will suspend all equipment functions.	High (Action 2)/ Medium (Action 1)
7	Space Temperature out of range alarm	The space temperature has exceeded the defined range (which can be set on the alarm limits screen). This applies to any sensor acting as the space temperature sensor, including network inputs.	Thermostat triggers an alarm.	Medium

S.NO	Alarm	Trigger Scenario	Action	Level
8	Space Humidity Sensor Failure	<p>1. The Local Space Humidity sensor is used as the primary data source for control, and a fault has been detected in this sensor.</p> <p>2. The Remote Space Humidity sensor is used as the primary data source for control, and a fault has been detected in this sensor.</p> <p>3. When multiple Space Humidity sensors are used as the primary data sources for control, faults have been detected in one or more of these sensors.</p>	<p>1. If the sensor is utilized for control loops and network input for temperature/humidity is available, the thermostat will only trigger an alarm.</p> <p>2. If network input for temperature/humidity is not available, the thermostat will disable all control functions (e.g., humidity control for humidification or dehumidification) related to the malfunctioning sensor.</p>	High (Action 2)/ Medium (Action 1)
9	Unknown Time	The thermostat has been disconnected from power for an extended period, causing the real-time clock (RTC) to reset.	Update the date and time.	Medium
10	Drain pan sensor alarm	The user can set up the DIO/UIO terminal as a binary input to monitor water leakage. When this input is activated, a drain pan alarm will be initiated.	<p>Users can configure the actions to be taken when a drain pan alarm is detected:</p> <ol style="list-style-type: none"> 1. Disable cooling. 2. Disable heating. 3. Disable fan 	High
11	Pipe sensor failure/out of range	<p>If a fault is detected with the pipe sensor, or if the pipe temperature falls outside the specified range, the system will respond accordingly. Configurable range settings can be adjusted in the 'Alarm Limits' section:</p> <p>High Limit: Default at 180 °F (range: 70 °F to 220 °F). Low Limit: Default at 40 °F (range: 30 °F to 60 °F)</p>	Both heating and cooling functions will be deactivated.	High

S.NO	Alarm	Trigger Scenario	Action	Level
12	Water temperature is not suitable for Heating/ Cooling	<p>Applicable only for Dual-Pipe FCU Heating/Cooling Systems.</p> <p>1. Based on the Pipe Sensor transition mode:</p> <p>a. If Hybrid Control is set to Off:</p> <p>For heating: If the Pipe Sensor reading is below the Pipe Sensor Threshold for Heating.</p> <p>For cooling: If the Pipe Sensor reading is above the Pipe Sensor Threshold for Cooling.</p> <p>b. If Hybrid Control is set to On:</p> <p>For either heating or cooling: Even if the Pipe Sensor reading is below or above the corresponding threshold, no alarm is triggered if it is within 5°F (configurable Temp Offset) of the space temperature. However, if it remains below or above the respective threshold for 4 hours (configurable Timeout Timer), an alarm is triggered..</p> <p>2. Based on Network Input Changeover Mode: If ni_pipetempmode is opposite to the current heating or cooling mode or is set to 'no use'.</p> <p>3. Based on Changeover Switch Mode: If the switch is set to heating while the current mode is cooling, or if the switch is set to cooling while the current mode is heating.</p>	The heating/cooling valve will be closed, and the fan will run based on the fan speed configuration. During the alarm, use a purge interval of 0.5 to perform a pipe purge.	High
13	Room temperature changing trend is reversed with system mode	<p>1. If heating is enabled, but the temperature drops by $\geq 1^{\circ}\text{F}$ or more within 30 minutes, an alarm will be triggered.</p> <p>2. If cooling is enabled, but the temperature increases by $\geq 1^{\circ}\text{F}$ or more within 30 minutes, an alarm will be triggered.</p>	<p>Depend on the alarm configuration:</p> <p>1. If the toggle button is turned off, only the alarm will be reported.</p> <p>2. If the toggle button is turned on, both heating and cooling will be deactivated.</p>	High
14	Shutdown alarm	If the shutdown signal is active, it is received either from an external source or from the wired shutdown sensor.	All control outputs, including the freeze protection heat, will be turned off.	High
15	Heat pump disabled alarm	"When the water source heat pump is configured, this alarm is triggered only by the network input ni_WSHPEnableState. This network input determines the status of the water source heat pump. When this BACnet point is valid and its value is 1, it will trigger the 'heat pump system disabled' alarm.	If a heat pump system disabled alarm is detected, the compressor output will be disabled, and the water flow valve will turn off. However, the PID (terminal load) will continue to run when there is a heating or cooling demand. Auxiliary heat will still be available, and the fan will continue to operate normally.	High

S.NO	Alarm	Trigger Scenario	Action	Level
16	Outdoor air temp sensor failure	Open/short limit is detected on outdoor air sensor(TC500:UI1/UI2/UIO1/UIO2);; TC300: UIO1-UIO3/DIO1/DIO2/Sylk address 8)	The application shall disable all control functions associated with the failed sensor. The thermostat will react as if the sensor was not configured. OAT/Compressor/Aux lockout will have no effect. Recovery Ramp Rate: Since the outdoor air temperature affects the setpoint recovery ramp, the thermostat will recalculate the recovery ramp rate.	High
17	Outdoor air temp out of range	Outdoor Air Temp out of Range, and high/ low limits can be configured: Low(-40 to 60 °F), High(70 to 150 °F). default low: -40 °F, high: 150 °F.	The control function will not be disabled. Please check the equipment for proper operation.	Medium
18	Wi-Fi connection lost Alarm.	When the Wi-Fi connection lost with disconnect of Internet/BACnet IP.	Wi-Fi connection lost alarm notification banner will appear on the home screen if enabled. Alarm details can be viewed on the alarm detail page.	Low
19	Wi-Fi network not configured Alarm	When user tries connect the thermostat to a Wi-Fi network without Wi-Fi configuration in the thermostat. The Wi-Fi connection will not be established.	Wi-Fi network not configured and alarm notification banner will appear on the home screen if enabled. Alarm details can be viewed on the alarm detail page.	Medium
20	Honeywell Cloud Connection Failure Alarm	The thermostat is already registered with the Forge cloud but lost the connection to the cloud and mobile app.	Thermostat cannot communicate with Forge cloud and Mobile app. Cloud connection failure alarm notification banner will appear on the home screen if enabled. Alarm details can be viewed on the alarm detail page.	High
21	Cloud Connection Is Not Detected Alarm	Thermostat is connected to the Wi-Fi but cloud registration is not performed.	Cloud connection is not detected alarm notification banner will appear on the home screen if enabled. Alarm details can be viewed on the alarm detail page.	Medium
22	Occupancy Sensor Failure Alarm	For a TC300 which has an onboard occupancy sensor, when the sensor failure is detected, will trigger this alarm.	Thermostat will react as if the sensor was not configured. For hospitality scenario: If there are other valid occupancy value from remote sensor and network input, the thermostat will use these valid values to calculate. Once all the occupancy sensor values are lost, the thermostat cannot calculate occupancy status. It will remain unoccupied until the next "UDI" Usage, Door or Ingress. After that, it will REMAIN occupied and not begin the next unoccupied transition.	High

S.NO	Alarm	Trigger Scenario	Action	Level
23	Entry Door Open Detected Alarm	User can configure DIO/UIO terminal as binary input to detect entry door open. When this binary input remains active for a certain time (30 to 300 seconds, default 120s), Entry door open alarm will be triggered. (only for hospitality)	<p>Thermostat will trigger an alarm then act follow configured action</p> <p>User can configure the operation would be taken when entry door open alarm is detected</p> <p>No Action(default)</p> <p>Disable HVAC system</p> <p>Switch to Unoccupied mode</p> <p>Alarm Only</p> <p>Actions related control logic:</p> <p>No Action (default): This means the thermostat will not trigger an entry door open alarm. The sensor value is only used to participate in calculating the room's occupancy status.</p> <p>Alarm Only: In this case, besides being used in occupancy calculation, the entry door open alarm will also be displayed, but it will not affect other control behaviors.</p> <p>Disable HVAC System: Besides being used in occupancy calculation, after the alarm is triggered, the thermostat will shut down the heating (include aux heat), cooling, and fan outputs.</p> <p>Switch to Unoccupied Mode: Besides being used in occupancy calculation, when the alarm is triggered, the room status will change to "unoccupied," and the thermostat will operate in unoccupied mode.</p>	High
24	Light Sensor Failure Alarm	For a TC300 which has an onboard light sensor, when the sensor failure is detected, will trigger this alarm.	<p>Thermostat will react as if the sensor was not configured.</p> <p>For hospitality scenario:</p> <p>When light sensor values are lost, the thermostat cannot know which point per minute to use between wake and sleep points. It will use Room dark "21 points per minute" to do motion only logic.</p>	High

S.NO	Alarm	Trigger Scenario	Action	Level
25	Balcony/ Window Open Detected Alarm	User can configure DIO/UIO terminal as binary input to detect balcony/window open. When this binary input remains active for a certain time (30 to 300 seconds, default 120s), alarm will be triggered.	<p>Thermostat will trigger an alarm then act follow configured action</p> <p>User can configure the operation would be taken when balcony/window open is detected</p> <p>Disable HVAC system(default)</p> <p>Switch to Unoccupied mode</p> <p>Alarm Only</p> <p>Actions related control logic:</p> <p>Alarm Only: In this case, the balcony/window open alarm will be displayed, but it will not affect other control behaviors.</p> <p>Disable HVAC System: after the alarm is triggered, the thermostat will shut down the heating(include aux heat), cooling, and fan outputs. However, if the room temperature reaches the freeze protection alarm threshold, the heating will re-enabled until the temperature rises above the threshold and the freeze protection alarm is cleared. Once the freeze protection alarm is cleared, the HVAC system will return to the window open alarm shutdown state unless the window is closed and the alarm is reset.</p> <p>Switch to Unoccupied Mode: when the alarm is triggered, the room status will change to "unoccupied," and the thermostat will operate in unoccupied mode.</p> <p>*For residential and fix setpoint, don't support "Switch to Unoccupied Mode".</p> <p>if original is "switch to Unoccupied" then change schedule to fixed setpoint/residential, the action option should be back to "disable HVAC system"</p>	High

S.NO	Alarm	Trigger Scenario	Action	Level
26	CO2 Sensor Failure Alarm.	<p>Precondition When the CO2 sensor malfunctions or fails, the system should be capable of promptly issuing an alert to ensure indoor air quality and the health safety of users.</p> <p>Onboard CO2 sensor fails.</p> <p>If the Space CO2 sensor value is invalid the sensor is considered to have failed</p>	<p>CO2 sensor bad, sensor fault alarm with high priority.</p> <p>The application shall disable all control functions associated with the failed sensor; i.e. it will react as if the sensor was not configured.</p>	High
27	Space CO2 limit exceeded Alarm.	<p>Precondition: user can configure CO2 Alarm limit:400 to 2000ppm, default 1100, step 50.</p> <p>if a binary CO2 Output has been configured, the Minimum value of the CO2 alarm limit cannot be lower than CO2 output threshold limit.</p>	<p>Add option under Display Options to Display Alert (Alert will display on main screen – recommended once/ 10 minutes for 10 seconds dimming)</p> <p>Fixed hysteresis(deadband) of 100 ppm</p> <p>Visual alert will continue as long as threshold is exceeded.</p>	Medium

About schedule

TC300 thermostats enable you to plan operations based on the time of day and holidays.

This scheduling structure allows you to control day-to-day operations with the standard schedule. The holiday schedule controls days or times when a facility is typically unoccupied. The event schedule controls periods outside normal occupied times. The holiday schedule overrides the standard schedule and the event schedule overrides the holiday and standard schedules within a schedule set.

Schedules use the setpoint configuration of Occupied, Unoccupied, or Standby modes.

Occupied mode treats the building space as occupied and configured with comfort setpoints.

Unoccupied mode treats the building space as not occupied and configured with energy savings setpoints.

Standby mode setpoints are configured in a way that the setpoints can quickly change to the Occupied mode when switched. Standby mode setpoint saves energy higher than occupied mode and lesser than the Unoccupied mode.

Temporary mode allows the user to change the temperature setpoints of the Occupied mode after the user switches to the temporary mode from the Occupied mode. This is not possible in Unoccupied mode and Standby mode.

When a schedule uses the Occupied mode but the Occupancy sensor reads unoccupied, then the thermostat switches automatically to the Standby mode. In other scenarios, the thermostat follows the schedule status and the occupancy sensor's value has no impact on it.

How schedules works

When you set up schedules, it is important to understand the relationship of the schedules in the schedule set and how to use each one.

- **Standard schedule:** Use the weekly schedule to program occupied and standby periods for each of the week.
- **Holiday schedule:** Use holiday schedules to set holidays that “Recurring” or occur on a fixed date each year. Up to 10 holidays can be created.

- **Special event:** Use Special event to create up to 10 special events.
- **Vacation:** Use Vacation Schedules to set the vacation that “Recurring” or occur on a fixed date each year.

Note: *Holiday schedules automatically write a 12:00 AM OFF time, which is in effect unless it is overridden by an event schedule.*

Related topics

[Commercial schedule](#)

[Holiday schedule](#)

[Special event](#)

[Residential Schedule](#)

[Vacation Mode](#)

[Fixed Setpoints](#)

[Hospitality](#)

Commercial schedule

Weekly Schedule

To add a new time value to a weekly schedule

1. Swipe left from the Home screen.
The Quick access screen appears.

Figure 184 Quick access screen

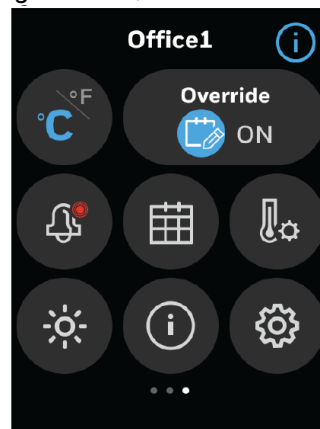

2. On the Quick access screen, tap  **Schedule**.
The schedule main screen appears which lists all types of schedules available in the thermostat.

Figure 185 Schedule types



3. Tap **Weekly** to add a new schedule.
The Weekly screen appears.

Figure 186 Weekly schedule screen

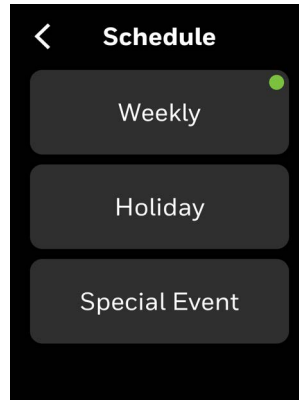
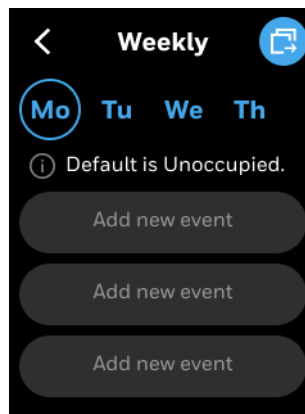

4. Select a day when to apply the weekly schedule.
5. Tap **Add new event**
The Create screen appears.
It displays two event types for scheduling. Occupied and Standby.

Figure 187 Weekly event screen

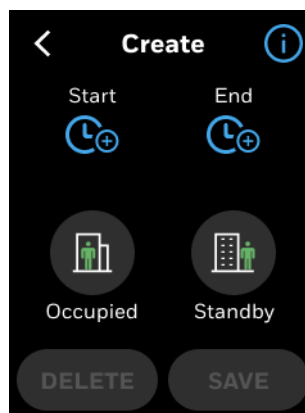

6. Tap the information icon to read the schedule events limits.

Figure 188 Weekly Schedule help information

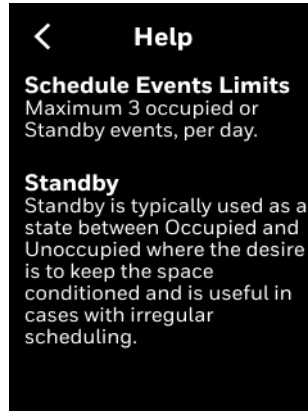

7. Set the start and end time for the event.
8. Tap an event type (Occupied or Standby).
9. Tap **SAVE**.

The Weekly screen appears. It displays the created schedule under Monday. You can copy the schedule to other days. Refer to [Copy the schedules from one day to another](#).

Figure 189 Weekly schedule.

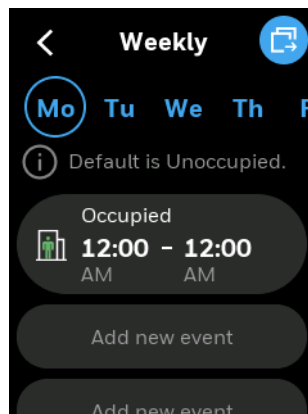

Note: *Scroll horizontally to view the entire screen.*

10. To add another schedule, tap **Add new event**.
11. Tap the back button to exit the scheduling.

Note: *System would be unoccupied automatically outside the scheduled time slot.*

Edit or delete weekly schedules

The existing weekly schedules can be edited from the Weekly schedule screen.

To change or delete an existing weekly schedule

1. On the **Weekly schedule** screen, tap the schedule to be modified.
The Edit screen will appear.

Figure 190 Editing a regular schedule

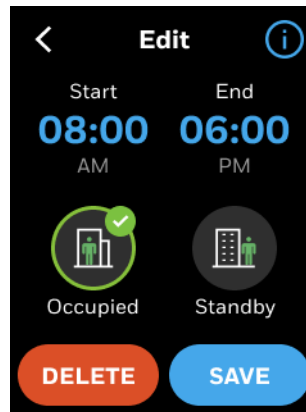

2. Select the new Start and End time and mode.
3. Tap **SAVE** to save changes or Tap **DELETE** to delete the schedule.

Copy the schedules from one day to another

The TC300 thermostats enable the user to copy an existing regular schedule.

To copy a schedule from one day to another

1. Navigate to the Weekly schedule screen from where the schedule is to be copied. Select a day to copy.
2. Tap  to copy schedules from Monday. Copy screen will appear.

Figure 191 Copy Schedule



3. Tap on the days of the week for which schedule is to be copied.

Figure 192 Select Days

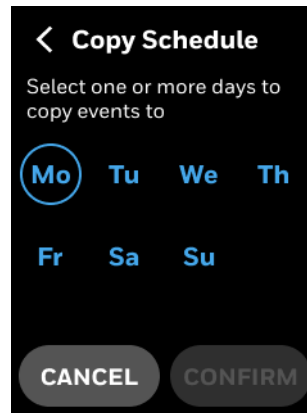
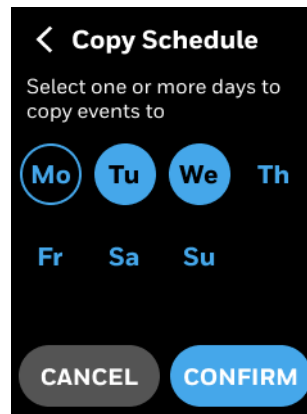

4. Tap **CONFIRM**.
Schedule copied successful confirmation message appears.

Figure 193 Copy successful

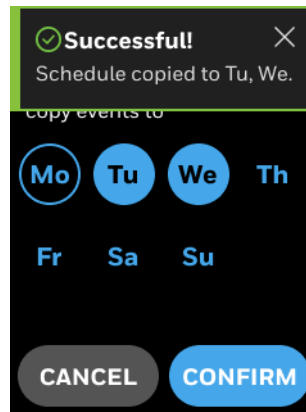

Holiday schedule

Holidays are defined as reoccurring events that are different from the weekly schedule, can be Occupied or Standby, or by default Unoccupied. So the Unoccupied/Standby mode setpoints will be executed on the holidays. There are two holiday types available to choose. There are **Floating date** and **Specific date**. Only one day can be selected for the floating holiday type whereas multiple days can be selected for Specific date type.

A maximum of 10 holiday events can be created.

To schedule a holiday

1. Swipe left from the Home screen.
The Quick access screen appears.

Figure 194 Quick access screen

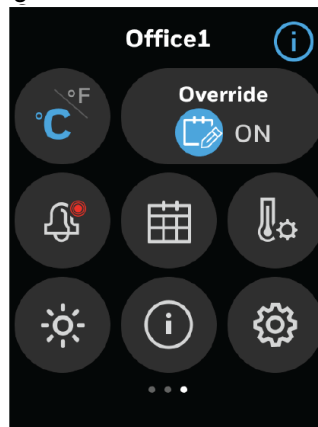

2. On the Quick access screen, tap  **Schedule**.

Figure 195 Schedule types

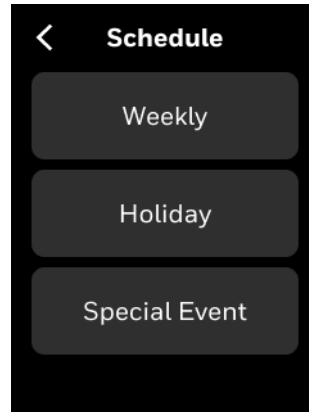

3. Tap **Holiday** to add a new holiday schedule.
The Holiday screen appears.

Figure 196 Holiday screen

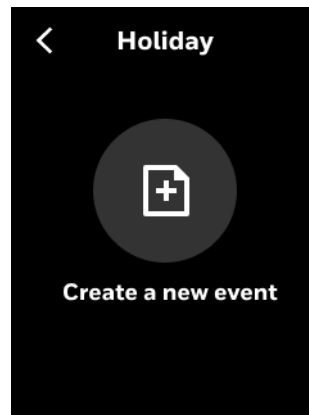

4. Tap the add button to add a Holiday.
The Create Holiday screen appears.

Figure 197 Creating Holiday

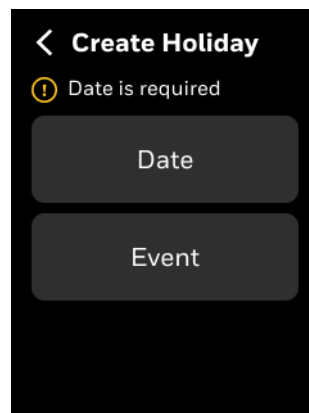

5. Tap **Date**.
The Set Date screen appears.

Figure 198 Set Date

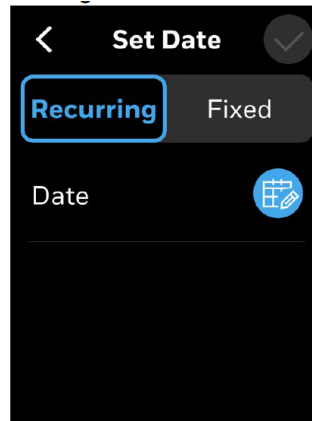

6. Tap **Recurring Date** to schedule a Recurring date as a holiday (Organization related holidays) or tap Fixed Date to schedule festival holidays, government holidays, or public holidays.
If Recurring date is selected, then you can choose only one day to create an event.
7. Tap the clock icon.
8. Select a date.
9. Tap **CONFIRM**.
The Set Date screen appears. If you are configuring a Specific Date holiday type, then you can add multiple days by tapping the **How is the holiday** with first date is fixed date.
10. Tap **Save**.
The Create Holiday screen appears.
11. Tap **Event** to configure the actions to be executed on the configured holiday (s).
12. Tap **Set Event**.
Event list screen for the set date appears. You can add a maximum of four events.

Figure 199 Date screen for special events

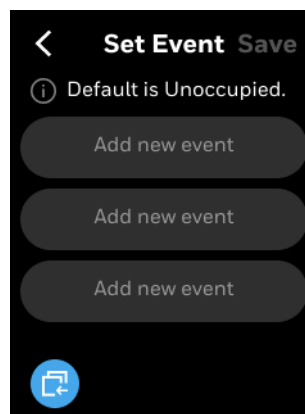

13. Tap **Add new event**.
The Create screen appears.

Figure 200 Create holiday vent screen

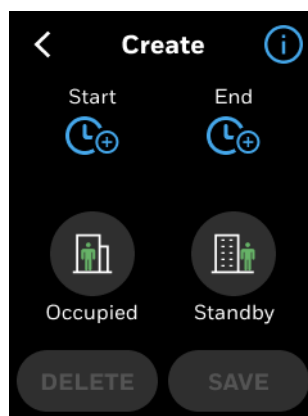

14. Tap the Start clock icon to set the event start time.
15. Set the start time and then tap **CONFIRM**.
16. Tap the End clock icon.
17. Set the event end time and then tap **CONFIRM**.
18. Tap **Occupied** or **Standby** based on your requirement.
19. Tap **SAVE**.
The created event appears on the Holiday screen.
20. Tap **SAVE**.
21. Tap **Done**.
The holiday creation successful message appears.

Edit or delete Holiday

The existing weekly Holidays can be edited from the Holiday screen.

To change or delete an existing holiday

1. On the **Holiday** screen, tap the schedule to be modified.
The Edit screen will appear.

Figure 201 Editing a regular Holiday

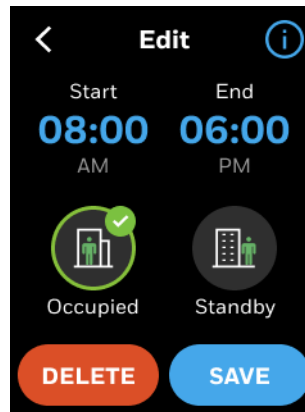

2. Select the new Start and End time and mode.
3. Tap **SAVE** to save changes or Tap **DELETE** to delete the schedule.

Copy the Holiday events from one day to another

The TC300 thermostats enable the user to copy an existing holidays.

To copy a schedule from one day to another

1. Navigate to the Holiday screen from where the holiday is to be copied.
Select a day to copy.
2. Tap  to copy holiday from Monday.
Copy screen will appear.

Figure 202 Copy holiday



3. Tap on the days of the week for which schedule is to be copied.

Figure 203 Select Days

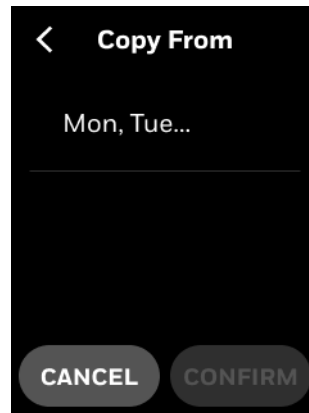
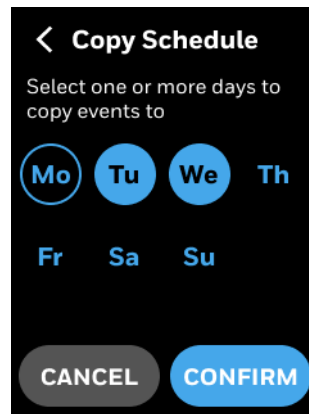

4. Tap **CONFIRM**.
Holiday copied successful confirmation message appears.

Figure 204 Copy successful

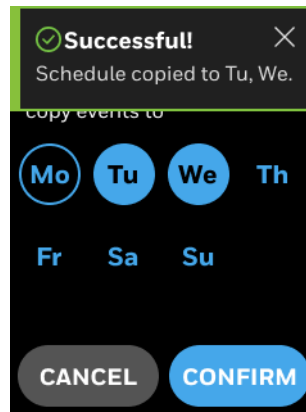

Special event

Special events are one time events that are different from the weekly schedule. A maximum of 10 special events can be created.

To create a special event

1. Right swipe the home screen.
2. On the Quick access screen, tap **Schedule** and then tap **Special Event**. The Special Event screen appears.

Figure 205 Special event screen

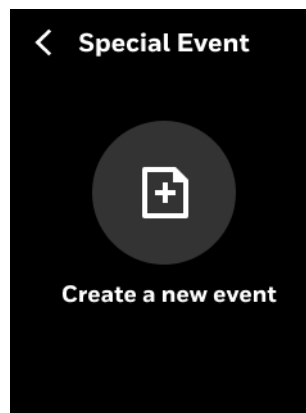

3. Tap the add button. The **Create Special Event** screen appears. Date is mandatory to create a special event.

Figure 206 Create special event

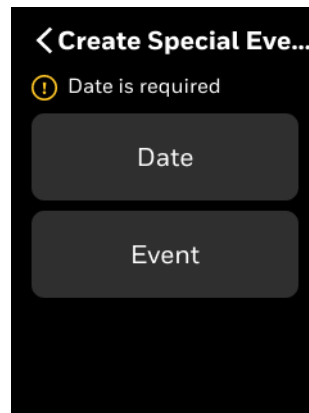

4. Tap **Date**.
The Set Date screen appears.

Figure 207 Set date screen

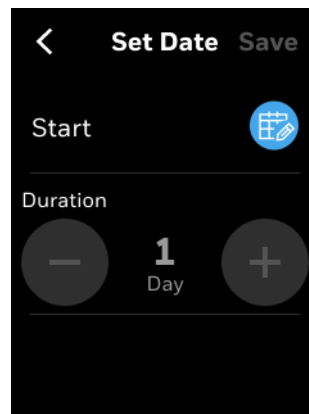

5. Select a date.

Note: *The thermostat supports special event configuration only for three years from the current date.*

If the special event reoccurs on multiple days, then increase the holiday count.

6. Tap **Done**.
The **Create Special Event** screen appears.
7. Tap **Event**.
Event list screen for the set date appears. You can add a maximum of four special events for the particular date.

Figure 208 Adding new event

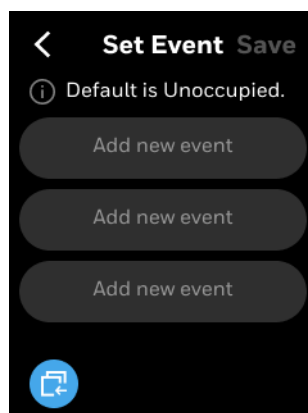

8. Tap **Add new event**.
The Create Event screen appears.
9. Tap the clock icon for Start.
10. Set the special event start time and then tap **CONFIRM**.
11. Tap the clock for End.
12. Set the special event end time and then tap **CONFIRM**.
13. Tap Occupied or Standby based on your requirement.
14. Tap **SAVE**.
The created special event appears under the special event date screen.
15. Tap **Save**.
16. Tap **Done**.
You have created a special event.

To delete a special event

1. On the special event screen, tap a special event.
A confirmation message appears.
2. Tap **DELETE**.
The special event is deleted.

Note: *Elapsed Special Events will automatically be deleted by the system.*

Residential Schedule

The Residential Schedule feature allows you to set and manage temperature adjustments based on your daily and weekly routines, ensuring both comfort and energy efficiency.

Key Features:

1 Schedule Event Types:

Wake: Set the temperature to the desired comfort level upon wake-up.

Away: Automatically adjust the temperature when leaving home to conserve energy.

Return: Configure the temperature to the preferred comfort level in preparation for return home.

Sleep: Maintain a comfortable sleeping temperature throughout the night.

Custom Event: Create a scheduled event with a specific name, temperature, and fan mode. For example, a “Weekend” event can be established with a distinct temperature setpoint.

Weekly Schedule

To add a new time value to a weekly schedule

1. Swipe left from the Home screen.
The Quick access screen appears.

Figure 209 Quick access screen

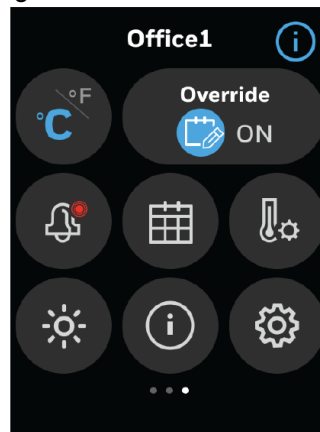

2. On the Quick access screen, Tap  Schedule to edit the weekly/vacation schedule.
The all types of schedule list available under Configuration - Basic configuration - Schedule Setting.

Figure 210 Schedule types



3. Tap **Weekly** to add a new schedule.
The Weekly screen appears.

Fig 211. Weekly schedule screen

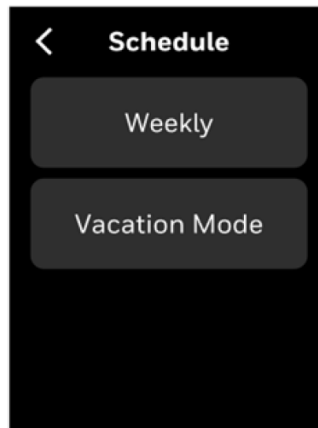
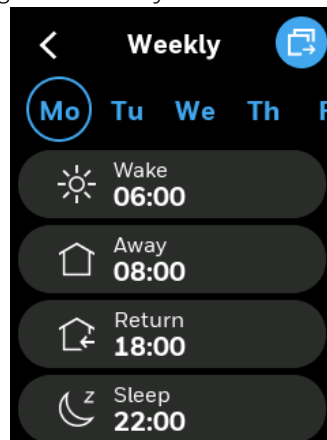

4. Select a day when to apply the weekly schedule.
5. Tap **Add new event**
The Create screen appears.
It displays two event types for scheduling. Occupied and Standby.

Figure 212 Weekly event screen

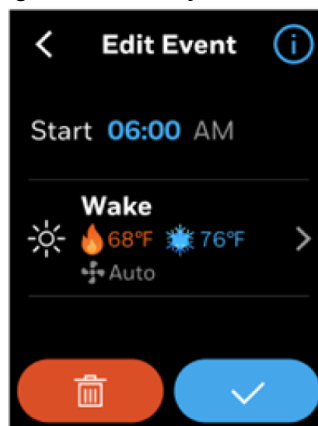

6. Tap the information icon to read the schedule events limits.

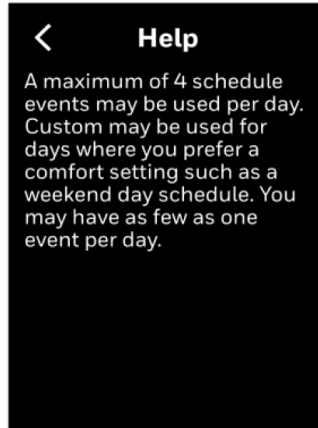
Figure 213 Weekly Schedule help information

7. Set the start and end time for the event.
8. Tap an event type (Occupied or Standby).
9. Tap **SAVE**.

The Weekly screen appears. It displays the created schedule under Monday. You can copy the schedule to other days. Refer to [Copy the schedules from one day to another](#).

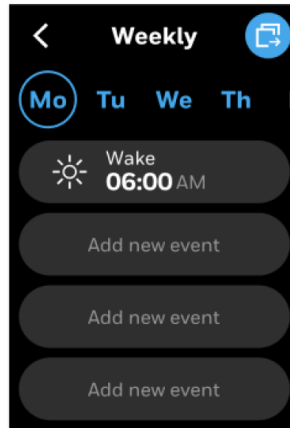
Figure 214 Weekly schedule.

Note: Scroll horizontally to view the entire screen.

10. To add another schedule, tap Add new event.
11. Tap the back button to exit the scheduling.

Note: System would be unoccupied automatically outside the scheduled time slot.

Edit or delete weekly schedules

The existing weekly schedules can be edited from the Weekly schedule screen.

To change or delete an existing weekly schedule

1. On the Weekly schedule screen, tap the schedule to be modified.
The Edit screen will appear.

Figure 215 Editing a regular schedule

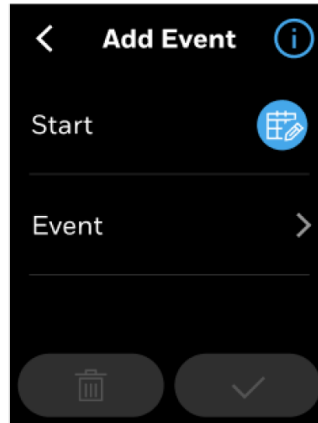

2. Select the new Start and End time and mode.
3. Tap SAVE to save changes or Tap DELETE to delete the schedule.

Figure 216 Delete weekly Schedules

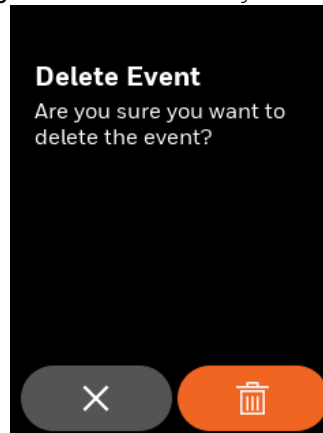

Copy the schedules from one day to another

The TC300 thermostats enable the user to copy an existing regular schedule.

To copy a schedule from one day to another

1. Navigate to the Weekly schedule screen from where the schedule is to be copied. Select a day to copy.
2. Tap  to copy schedules from Monday. Copy screen will appear.

Figure 217 Copy Schedule



3. Tap on the days of the week for which schedule is to be copied.

Figure 218 Select Days

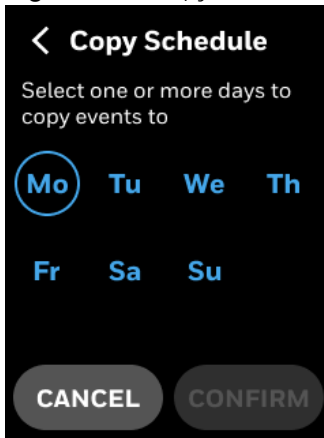
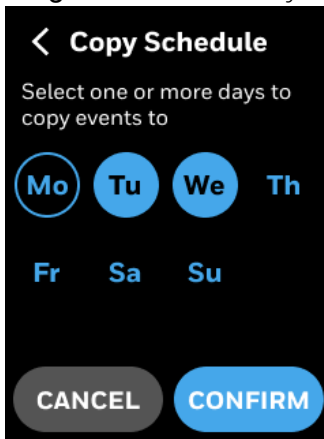

4. Tap **CONFIRM**.
Schedule copied successful confirmation message appears.

Figure 219 Copy successful

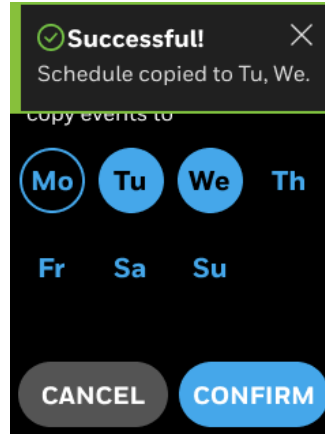

Vacation Mode

If you're going on vacation, you can set a special vacation period that overrides your regular schedule, ensuring energy savings while you're away.

To schedule a Vacation.

1. Swipe left from the Home screen.
The Quick access screen appears.

Figure 220 Quick access screen

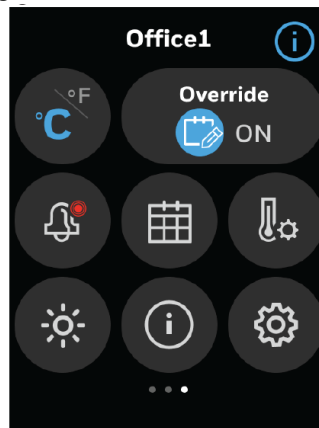

2. On the Quick access screen, tap  Schedule.

Figure 221 Schedule types

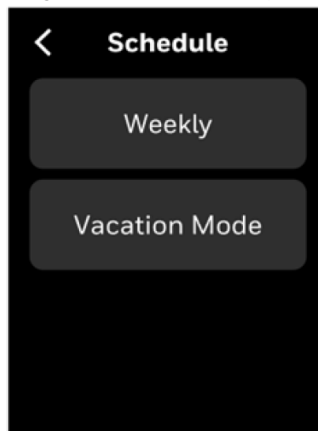

3. Tap **Create a New Vacation** event.
new vacation screen appears.

Figure 222 Set Vacation

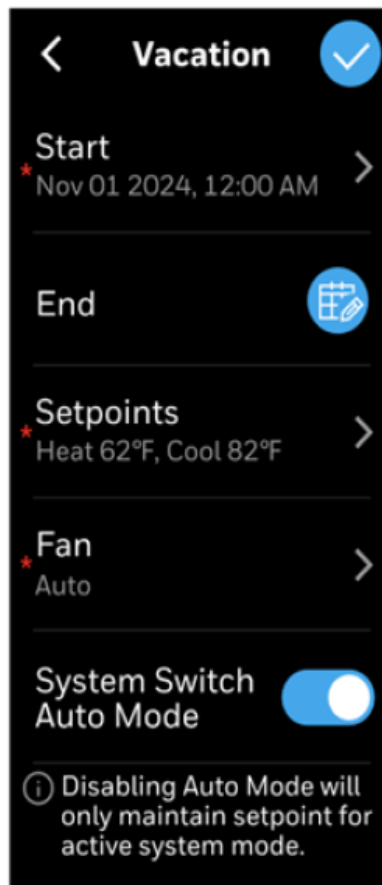

Set a Vacation then click ✓

4. Click **HOME** button will back to home screen.

Figure 223 Vacation

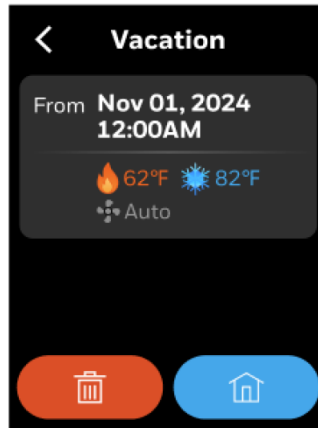

5. During Vacation period, Home Screen will show "Vacation"

Figure 224 Vacation period

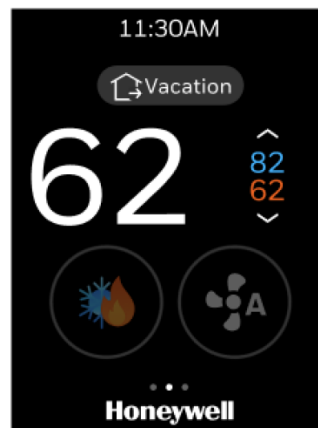

To delete a special event

1. On the vacation screen, tap a Vacation.
A confirmation message appears.

Figure 225 Vacation

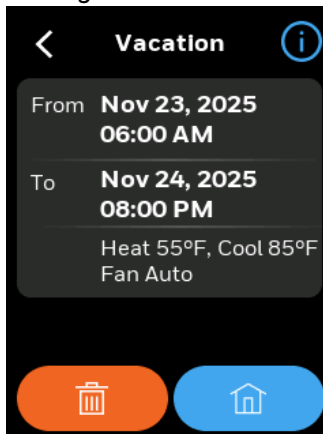

2. Tap **DELETE**.
The vacation is deleted.

Figure 226 Delete Event

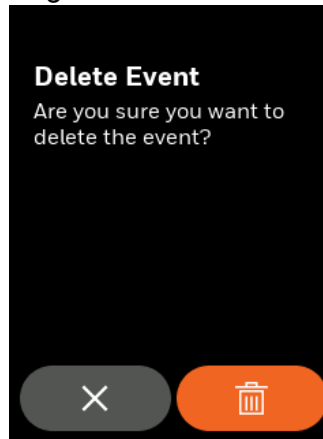

Fixed Setpoints

For each schedule event, you can assign specific temperature setpoints and fan modes to optimize both comfort and energy efficiency.

The 'Fixed Setpoint' provides simple, non-programmable temperature control, ensuring a constant temperature 24/7 without the need for scheduling configurations. This mode is ideal for users who prefer to maintain a fixed temperature at all times, without the need for automatic adjustments based on time of day or occupancy.

In Fixed Setpoint mode, you can easily adjust the temperature directly from the home screen. Any adjustment you make becomes the active setpoint, and the thermostat will maintain that temperature continuously until you change it again. There are no scheduled events or programming features in this mode, making it straightforward and easy to use for those who want consistent comfort at all times.

Fixed Setpoint workflow:

1. Choose the "**Fixed Setpoints**" option to start the setup process.

Figure 227 Fixed Setpoints

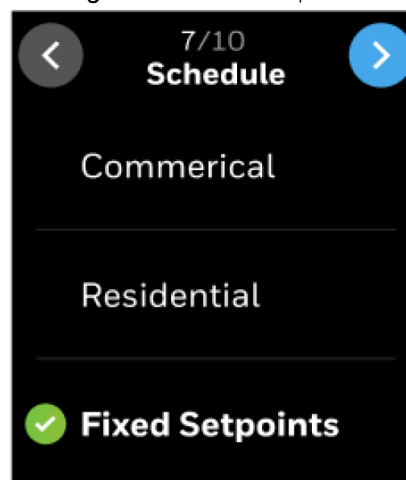

2. After selecting Fixed Setpoints, you will enter the setpoint configuration screen. Here, configure your desired **heat** and **cool** setpoints:

- Heat: Adjust the setting to your preferred temperature within the range of 40°F to 105°F.
- Cool: Adjust the setting to your preferred temperature within the range of 50°F to 115°F.

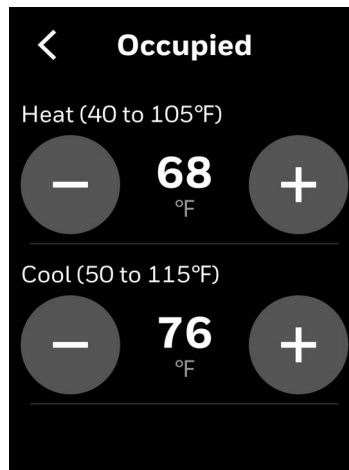
Figure 228 Heat/Cool setpoint

3. Once the setpoints are configured, you will be directed to the Home Screen. The temperature and setpoint are shown on this screen.

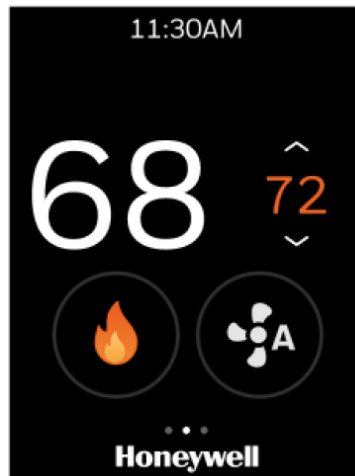
Figure 229 Home Screen Display

4. schedule and override buttons are hidden. This simplification is intended for easy access to your temperature settings.

Figure 230 Fixed Setpoint

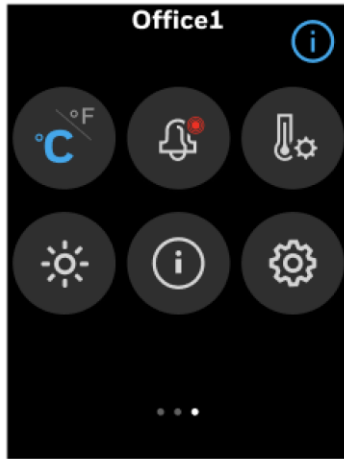

Hospitality

The Hospitality feature is designed to enhance energy efficiency and guest comfort in hotels. By integrating inputs from occupancy sensors, light sensors, and entry door switches, based on room occupancy status, the system automatically adjusts HVAC settings and lighting to reduce energy consumption while ensuring a pleasant environment.

1. Swipe left from the Home screen.
The Quick access screen appears.

Figure 231 Quick access screen

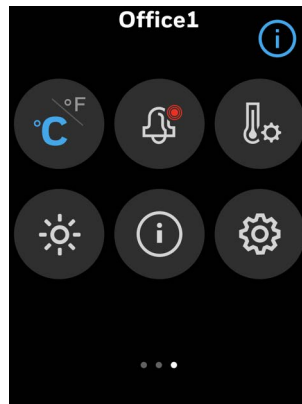

- The all types of schedule list available under Configuration > Basic configuration > Schedule Setting.
Choose Hospitality.

Figure 232 Hospitality

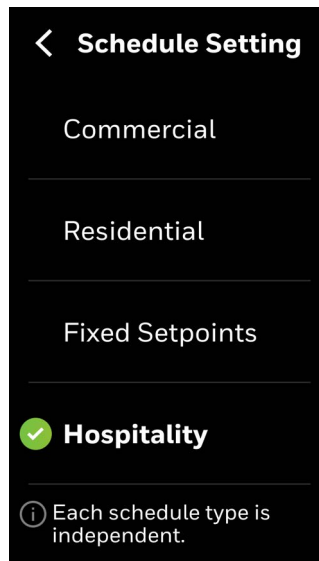

- The Setpoints screen appears.

Figure 233 Setpoints

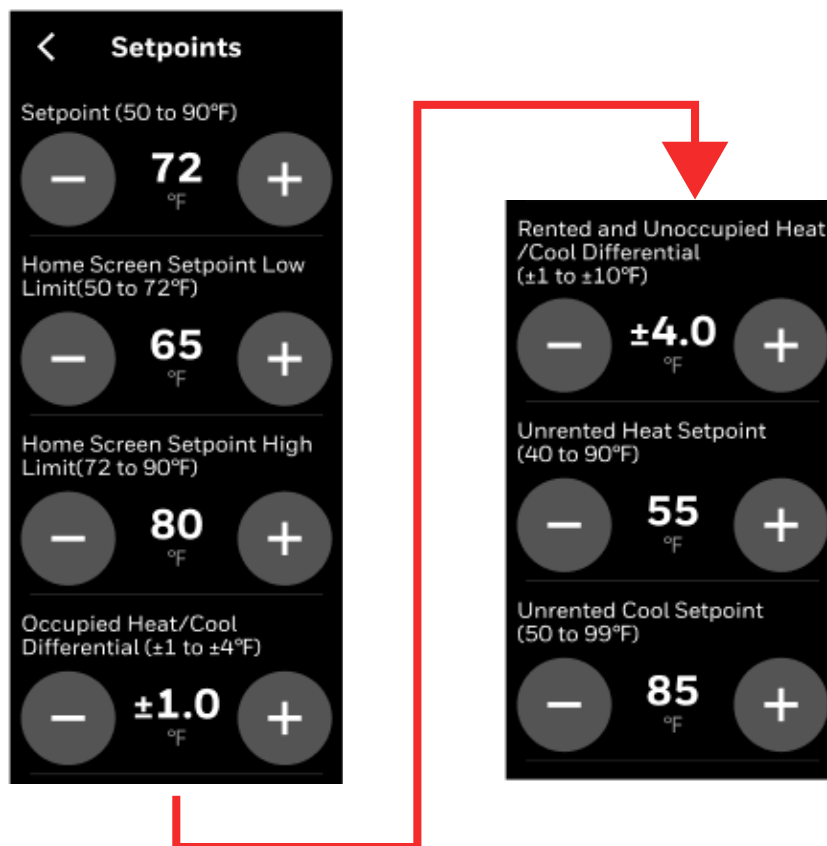

4. Tap “<” to return Home screen.

Figure 234 Home Screen

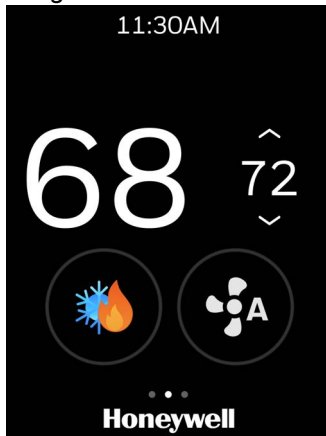

Manual Checkout for Unrented Status

Two Configuration Methods:

- Configuration through BAS and network variable.
- Manual configuration through the user interface (standalone implementation).

Rented Status Triggered Automatically:

- Activation triggered by both the door switch and motion sensor.
- Motion sensor activation only.

Figure 235 Home Screen

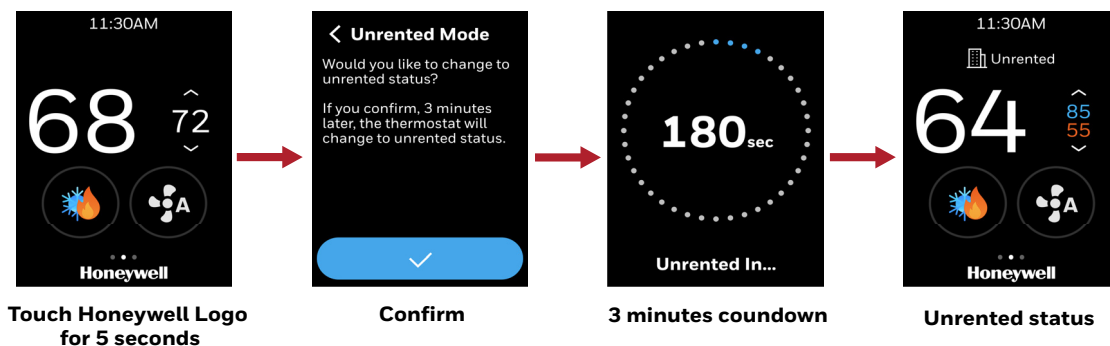

Table 36: Logic Table

Room State	Defination	Trigger Conditions
Rented & Occupied	The guest is physically present in the room.	The thermostat calculates this state based on Occupancy Status Change Logic confirming presence and activity.
Rented & Unoccupied	Guest has checked in, but the room is currently empty.	The thermostat calculates this state based on Occupancy Status Change Logic indicating no current activity.
Unrented	Room is vacant and has no active reservation.	Automatically set by Occupancy Status Change Logic or Manually checkout by a hotel staff long pressing Branding on main screen for 5 seconds.

Hospitality Mode Setting

1. Swipe left from the Home screen.

On the Quick access, tap  > **Configuration > Advanced > Hospitality**

Figure 236 Hospitality

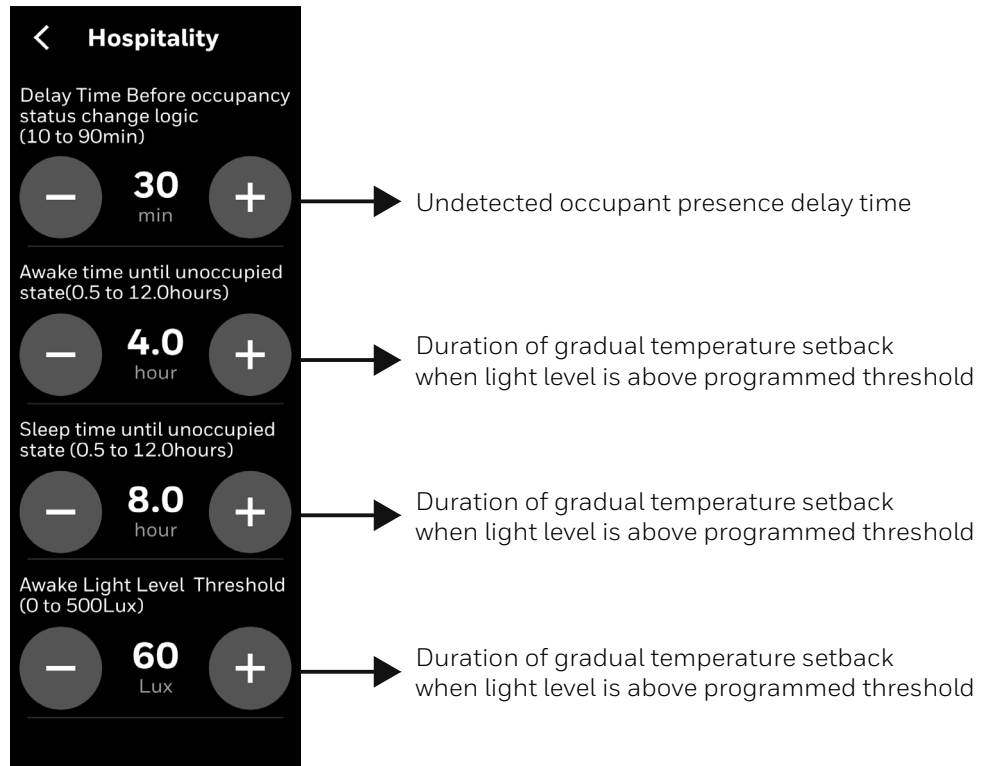

Light level setting in Lux is minimum light level threshold that triggers sleep time temperature setback algorithm.

Table 37: Logic Table

Hospitality Configuration	Description
Delay time before occupancy status change logic	Delay time to transfer from Occupied to the Occupancy Status Change Logic
Awake time until unoccupied state	Times for transitioning to an "Unoccupied" state in a bright room
Sleep time until unoccupied state	Times for transitioning to an "Unoccupied" state in a dark room
Awake light level threshold	Defines at what room illumination level we should consider the possibility that the occupant is sleeping or otherwise engaged

Setpoint Configuration

Guests can modify the target temperature directly from the Home Screen. When the room status changes, the thermostat automatically adjusts heating and cooling Setpoints according to predefined configurations.

The Setpoints Configuration screen lists settings in this order:

- Default target Setpoint for the Home Screen
- High/low adjustment limits for the Home Screen
- Differential for “Occupied” and “Rented and Unoccupied” states
- Heating/cooling Setpoint for the “Unrented” state

Lighting Control Output

User can Configure a lighting control output for controlling the lights in the room. When the room state changes to or remains Occupied, the lighting output remains Active. When the room state changes from Occupied to Unoccupied, the lighting output will remain active for 2 minutes delay time and then turn to Inactive. When the room status remains Unoccupied/Unrented, the lighting output remains Inactive.

Figure 237 Equipment

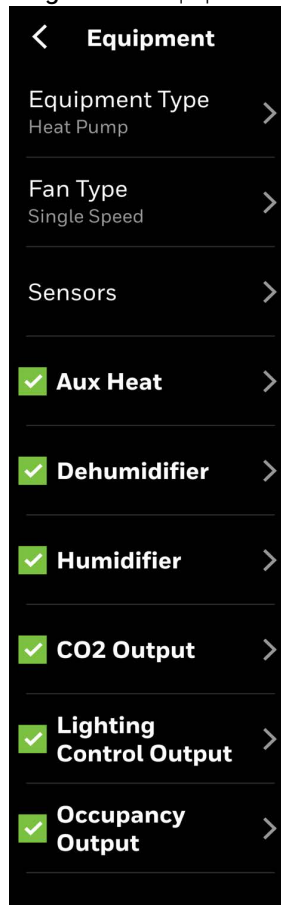

If the schedule type is Hospitality, users can configure a digital output as Lighting Control Output.

The lighting control output is configured to transfer the occupancy status to control room lighting.

A dedicated digital output terminal (available DO or DIO) is required to handle the occupancy signal:

The output logic should be as follows:

Occupied: Output should be ON (active) immediately.

Unoccupied and Unrented: Output should be OFF (inactive) after delay time.

Figure 238 Lighting Control Output

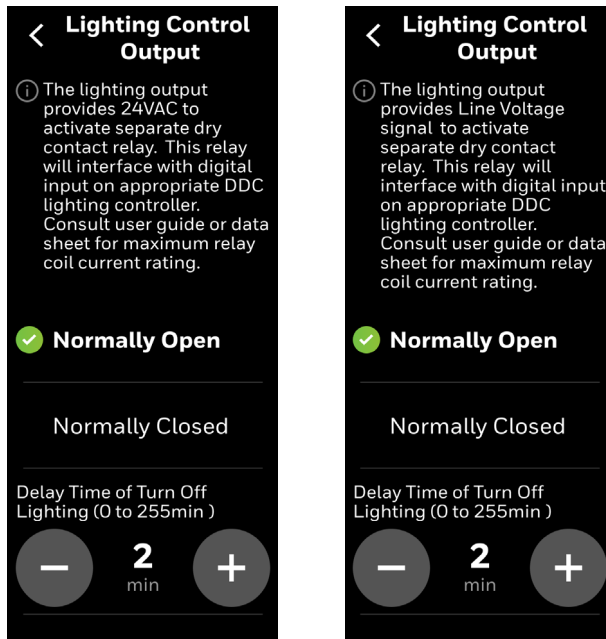

TC3xxB-G: The lighting output provides 24VAC signal to activate separate dry contact relay.

TC3xxC-G: The lighting output provides Line Voltage signal to activate separate dry contact relay.

This relay will interface with digital input on appropriate DDC lighting controller. For maximum relay coil current, please refer to TC300 Commercial Thermostats Datasheet (31-00645).

Figure 239 Lighting Relay Schematic

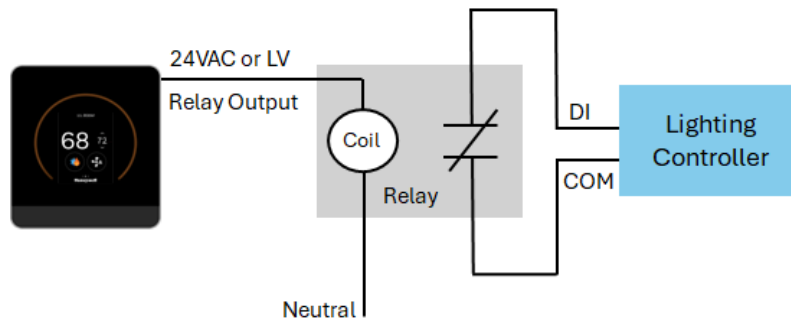

Honeywell | Building Automation

715 Peachtree Street, N.E.,
Atlanta, GA 30308,
United States.
[Buildings.honeywell.com](https://buildings.honeywell.com)

* U.S. Registered Trademark
© 2025 Honeywell International Inc.
31-00644-05 | Rev 11-25

