

S7999D1048 Combustion System Operator Interface Display

INSTALLATION INSTRUCTIONS

APPLICATION

The S7999D Combustion System Operator Interface (OI) reduces burner/boiler setup time by allowing the user to create a fuel/air modulation curve (profile) for ControLinks™ (Fuel/Air Ratio Control) that allows for safe and efficient operation at all points along the modulation curve. The OI uses a wizard like process to assist the user through the commissioning process. The S7999D can be used on systems with one or two fuels and on systems with or without flue gas re-circulation (FGR). The S7999D has two RS485 com ports that can be configured to provide:

- Fuel/Air Ratio Control commissioning and monitoring
- One or more boiler/burner systems monitoring (up to 99 burner/burner systems). Each burner control, Fuel/Air Ratio Control, and Expanded Annunciator present on each burner system can be viewed individually to determine its status.
- Local display to a System Monitor
- System Monitor to one or more Local displays
- Gateway for ModBus Master (BAS)

Universal Digital Controllers (UDC 2500/3200/3500 with modbus) can be used for several burner/boiler applications, and the S7999D can control the UDCs during their operation. Applications supported include:

- Stack temperature
- Water/steam PID load control
- Steam/fuel flow monitoring
- Thermal shock
- Feed pump level control

The S7999D is a multiple language OI; English and Spanish selectable.

The S7999D can be flush mount or behind mounted into a panel cutout.

Wiring connections to the S7999D are through a removable 8-pin wiring connector.

The S7999D also has a USB port that can be used for:

- Transfer screenshot images
- Transfer Trend Analysis Reports

- To upload:
 - (1) System OI application software revisions (when provided by Honeywell)
 - (2) Home page background image
 - (3) Home page logo
 - (4) Screen saver image

This document provides installation and initial setup instructions. Other applicable publications are:

- 65-0321 Combustion System Operator Interface Product Data manual

Documents can be viewed or downloaded at: <http://customer.honeywell.com>

SPECIFICATIONS

Electrical Ratings:

Input Voltage: 18 – 30 Vac (24Vac nominal), 50/60 Hz
 Input Current: 500 mA max
 Power consumption: 12W max

Operating Temperature: -4 to 158 °F (-20 to 70 °C)

Storage/Shipping Temperature: -22 to 176 °F (-30 to 80 °C)

Humidity: 90% RH, non condensing

Enclosure rating: IP10 / NEMA 1

Approvals:

FCC Part 15, Class A Digital Device
 Underwriter's Laboratories, Inc. (UL) (cUL)
 Component Recognized (for non-continuous operation):
 File Number MH17367 (MJAT2, MJAT8).

Dimensions: See Fig. 16

Replacement Parts

50063482-001 Bag assembly includes:

- 8-pin connector
- CR2032 coin battery
- Mounting hardware
- 3 clamp filters (1 for 24V power and 1 for each Modbus)



SAFETY FEATURES

The S7999D Display contains software that incorporates many features that are designed to guide you safely through the commissioning process. Safety, however, is your responsibility.

Read all documentation carefully and respond appropriately to all error messages

WARNING

Explosion Hazard.
Improper configuration can cause fuel buildup and explosion.

Improper user operation may result in PROPERTY LOSS, PHYSICAL INJURY or DEATH.

Using the S7999D Displays to change parameters, must be attempted by **only experienced and/or licensed burner/boiler operators and mechanics.**

INSTALLATION INSTRUCTIONS

The S7999D Display can be mounted on the door panel of an electrical enclosure.

1. Select the location on the door panel to mount the display; note that the device will extend into the enclosure at least one inch past the mounting surface.
2. Provide an opening in the panel door 8" wide X 5 1/2" high (for front panel mount) or 7 1/8" wide X 4 11/16" high (for rear panel mount). Use cutout templates provided in Fig. 17 and Fig. 18.
3. Place the S7999D Display in the opening and use it as a template to mark the location of the four mounting screw holes. Remove the device.
4. Using pilot holes as guides, drill 1/4 in. holes through the door panel.
5. Place the display in the opening, aligning the mounting holes in the device with the drilled holes in the panel.
6. Secure the display to the panel with four #6-32 screws and nuts provided.
7. Wire the 24 Vac power supply and the RS-485 cables using the wiring diagram in Fig. 1.

8. Ensure the 8-pin connector plug is aligned with the header pins when inserting the 8-pin connector plug back onto the Display. Secure firmly.

WIRING

The S7999D Display must be appropriately wired for both power and communications.

An external 24Vac power source must be supplied for the S7999D OI.

The communication is done over two RS-485 bus ports:

- COM1 and COM2 are universal and can be configured to provide:
 - Fuel/Air Ratio Control commissioning and monitoring
 - One or more boiler/burner systems monitoring (up to 99 burner/burner systems). Each burner control, Fuel/Air Ratio Control, and Expanded Annunciator present on each burner system can be viewed individually to determine its status.
 - Local display to a System Monitor
 - System Monitor to one or more Local displays
 - Gateway for ModBus Master (BAS)
- Refer to 65-0231 for complete networking options for the S7999D1048 Combustion System OI.

Table 1. 8-pin Connector Terminals.

Pin #	Function
1	COM1 A
2	COM1 B
3	COM1 C*
4	COM2 A
5	COM2 B
6	COM2 C*
7	24 Vac Common *
8	24 Vac Power

*These 3 terminals are connected internally and can be connected to earth ground.

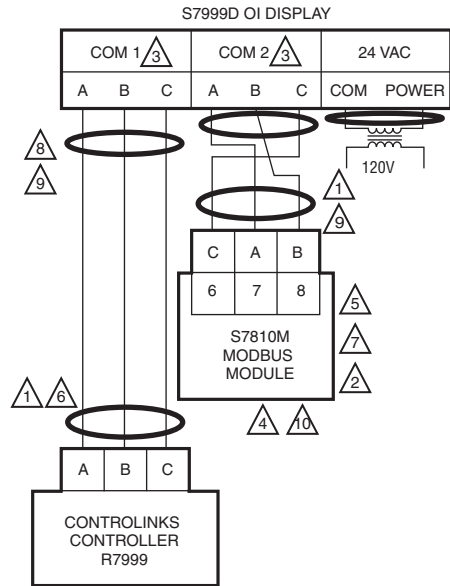

- 1 CONNECT SHIELD TO EARTH GROUND.
 - 2 SEE 65-0249 FOR CONTROL BUS (LOCAL RS-485 COMMUNICATION BUS) WIRING.
 - 3 "C" TERMINALS ARE CONNECTED INTERNALLY TO 24 VAC "COM".
 - 4 SEE 65-0249 FOR MULTIPLE S7810M NETWORK CONNECTIONS.
 - 5 MODBUS BAUD RATE SET FOR 19200 (COM2) AND 4800 (COM1).
 - 6 SEE 65-0238 FOR R7999 WIRING.
 - 7 120 Ω, 1/4 WATT RESISTOR BETWEEN TERMINALS A AND B OF THE MODBUS AT THE FARTHEST S7810M MAY BE NECESSARY FOR LONG RS-485 RUNS.
 - 8 TO PROTECT AGAINST CONDUCTED AND RADIATED TRANSIENT NOISE, USE CLAMP FILTERS (INCLUDED IN 50063482-001 BAG ASSEMBLY) AS ILLUSTRATED IN FIGURES 2 AND 3.
 - 9 RS485 WIRING: MAXIMUM 4,000 FEET WITHOUT RS485 REPEATERS.
 - 10 THE S7810M MODBUS MODULE MUST BE CONNECTED TO A 7800 SERIES BURNER CONTROL. (THE 7800 SERIES BURNER CONTROL GENERATES THE START BIT FOR THE MODBUS POLLING OF THE MEMBERS ON THE LOCAL MODBUS NETWORK).
- M33554

Fig. 1. S7999D basic wiring diagram

In this example, COM 1 is configured for commission fuel/Air Ratio Control, and COM 2 is configured for one or more burner/burner systems monitoring.) For network wiring and setup of the R7999, RM7800/S7810M, S7830 and UDC2500/3200/3500 with the S7999D, refer to 65-0231.

Clamp Filters

To protect against conducted and radiated transient noise, use clamp filters (included in 50063482-001 Bag Assembly). Install clamp filters on 24V, COM1, and COM2 wires. See Fig. 2 and 3.

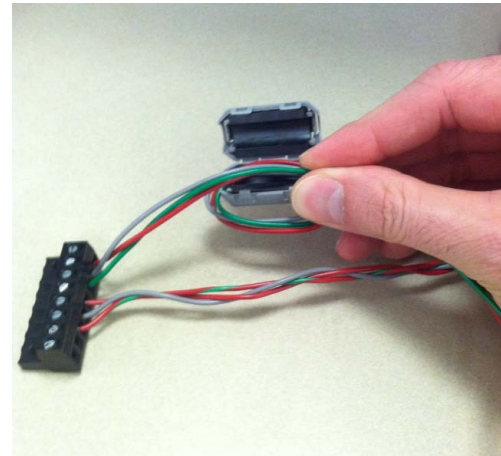

Fig. 2. Install clamp filters on 24V, COM1, and COM 2 wires.



Fig. 3. Clamp filter in place.

Battery

1. Remove battery compartment cover on back of the display.



Fig. 4. Battery compartment.

2. Install CR2032 coin battery (included in 50063482-001 Bag Assembly). Be sure to follow polarity markings on the display.



Fig. 5. Install CR2032 coin battery.

3. Replace battery compartment cover.

QUICK SETUP

Refer to 65-0321 Combustion System Operator Interface Product Data manual for complete OI setup and operation.

1. Make sure the S7999D 8-pin connector is properly aligned and pressed firmly in place.
2. Make sure the wires between the 8-pin connector and the controller are properly wired and secured.
3. Make sure the power supply is connected securely to the power source.



WARNING

Electrical Shock Hazard.

Can cause severe injury, death or equipment damage.

Line voltage is present at the 120 Vac power supply.

STARTING THE S7999D DISPLAY

Power-up Validation

The Home page will appear when the device is properly powered. Select the Setup button to adjust backlight and sound as desired. If the screen is dim, check Pin 7 and 8 wiring connections.

A “camera” icon on the left top corner is for screen snapshot use. Up to 16 snapshots can be stored in the display and can be copied to a USB memory stick.

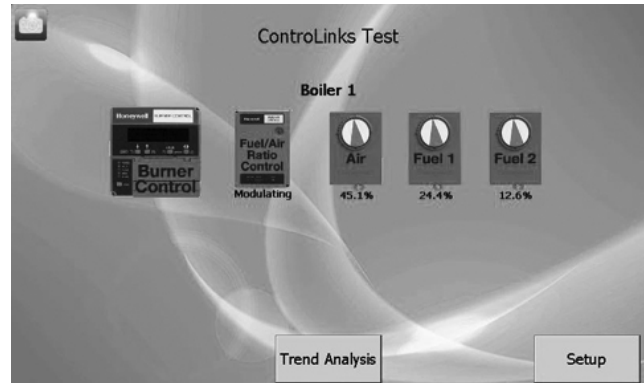

Fig. 6. S7999D Home Page (Burner 1 in normal operation).

NOTE: If no controllers or the OI has not synchronized with the Fuel/Air Ratio Control or the boiler/boiler network, then there will be no control icons on the Home Page.

SETTING UP S7999D DISPLAY

1. At Home Page, touch Setup Button. The Setup Page is displayed.

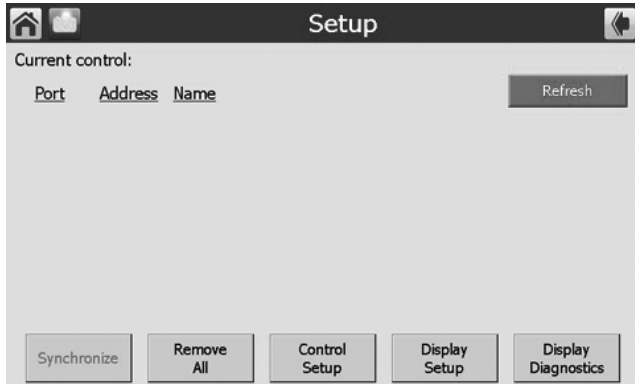

Fig. 7. Setup Page.

2. At Setup Page, touch Display Setup Button. The Display Setup Page is displayed.

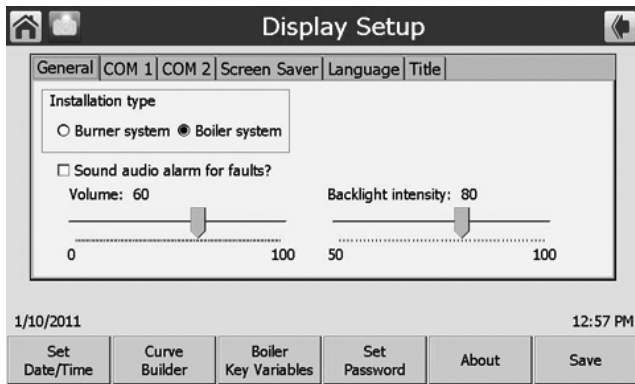

Fig. 8. Display Setup Page.

3. At Display Setup, touch Set Date/Time Button. The Set Date/Time Page is displayed. Also the Volume level (for touch audio feedback and alarm), Backlight intensity, Sound alarm for faults, Installation type (icon displayed when IO is connected to a network of multiple burner/boiler controls) can be adjusted.

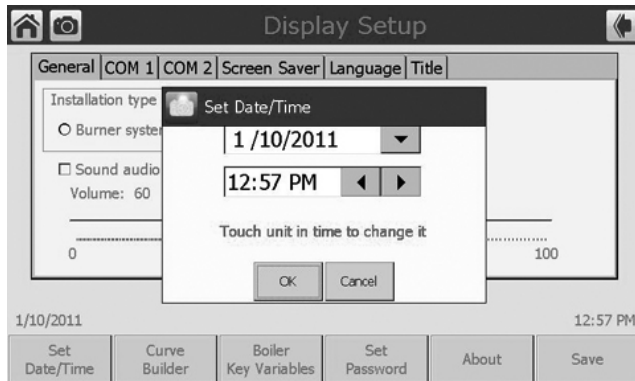

Fig. 9. Set Date/Time Page.

4. Set the Date and Time and touch OK.
5. Select Com 1 Tab to setup Com 1 port. In this example, Com 1 has been setup for commissioning of the ControlLinks R7999 F/A ratio controller (the baud rate will default to 4800 baud, this baud rate is required to be able to commission ControlLinks). Refer to 65-0231 for complete networking options.

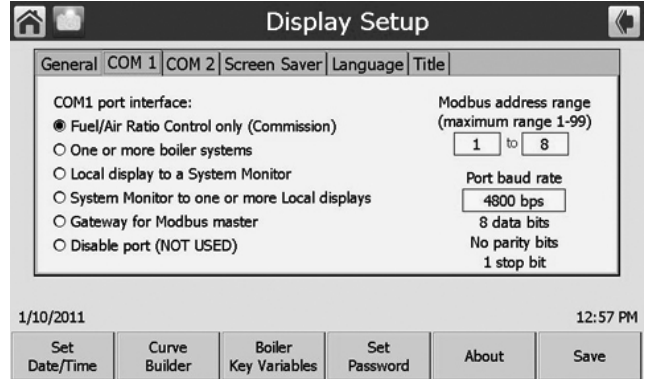

Fig. 10. COM 1 tab.

6. Select Com 2 Tab to setup Com 2. In this example, Com 2 has been set to monitor a boiler system. The baud rate must match the baud settings of the S7810M (9200 baud or 19200 baud). Ensure the Modbus Address range is set high enough for the address(es) of the S7810M Modbus Module(s) connected to Com 2.

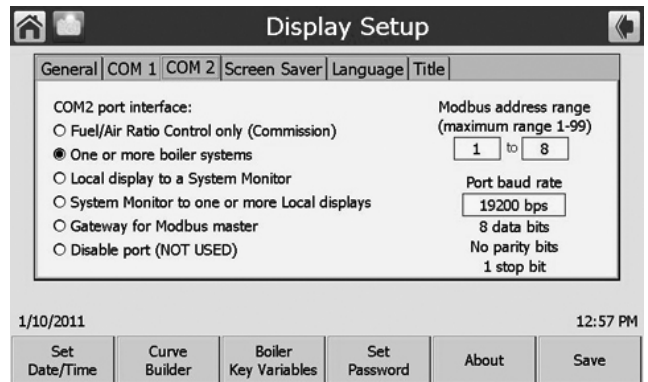

Fig. 11. COM 2 tab.

The other tabs allow selection of a screen saver option, Language option (English or Spanish), and the ability to add a title to the Home Page.

Refer to Product Data Manual 65-0321 for additional information for the Curve Builder, Boiler Key Variables, and Set Password Buttons.

If a Com port is not being used, select the Disable port option.

IMPORTANT

Once completed with Display Setup, touch the Save button.

7. Touch the “page back” button (arrow button in the upper right hand corner).

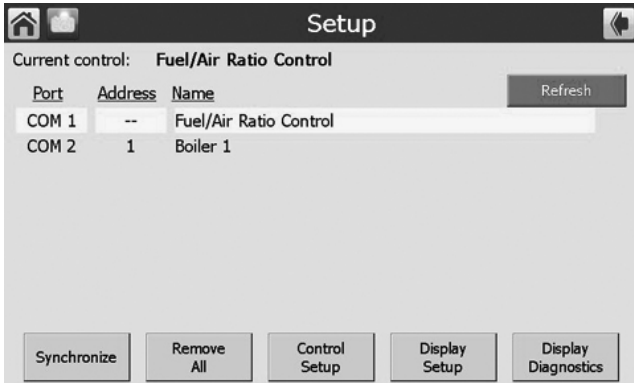

Fig. 12. Setup Page.

8. Touch the Refresh button to connect the S7999 to the device(s) connected to the Com Port(s). In this example, Com 1 is connected to a ControlLinks R7999 F/A Ratio Controller for commissioning or monitoring and Com 2 is connected to a boiler system.
9. Touch the Home Page button (House icon in the upper left corner).

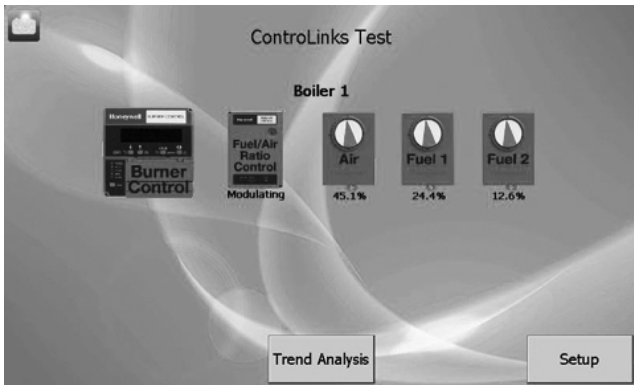

Fig. 13. Home Page.

Home Page showing the devices that are communicating with the S7999D display; RM7800 through the S7810M Modbus Module (Com 2 in this example) and the ControlLinks R7999 F/A ratio controller (Com 1 in this example).

10. Touch the device icon to monitor or commission the various devices shown on the Home page.

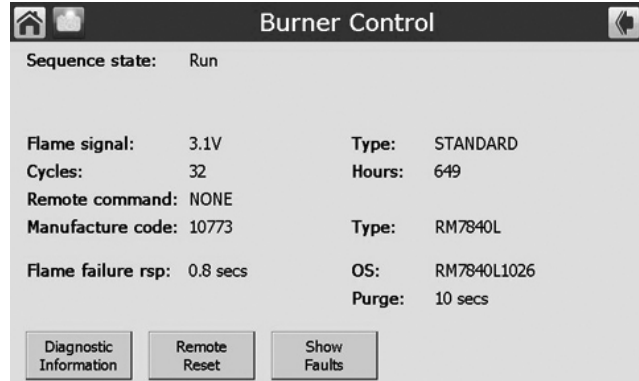

Fig. 14. Burner Control Status Page.

11. Touch the Fuel/Air Ratio Control for monitoring or commissioning the ControlLinks R7999 controller.

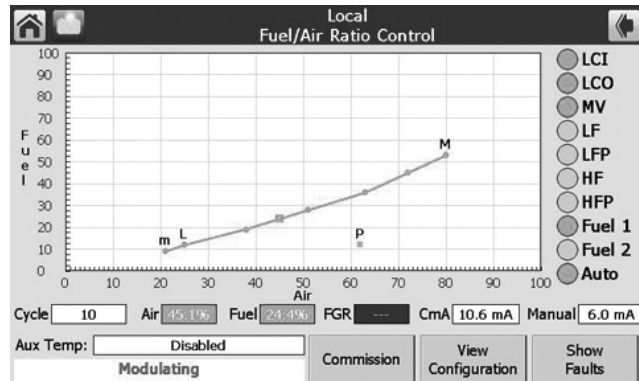

Fig. 15. Fuel/Air Ratio Control Status Page.

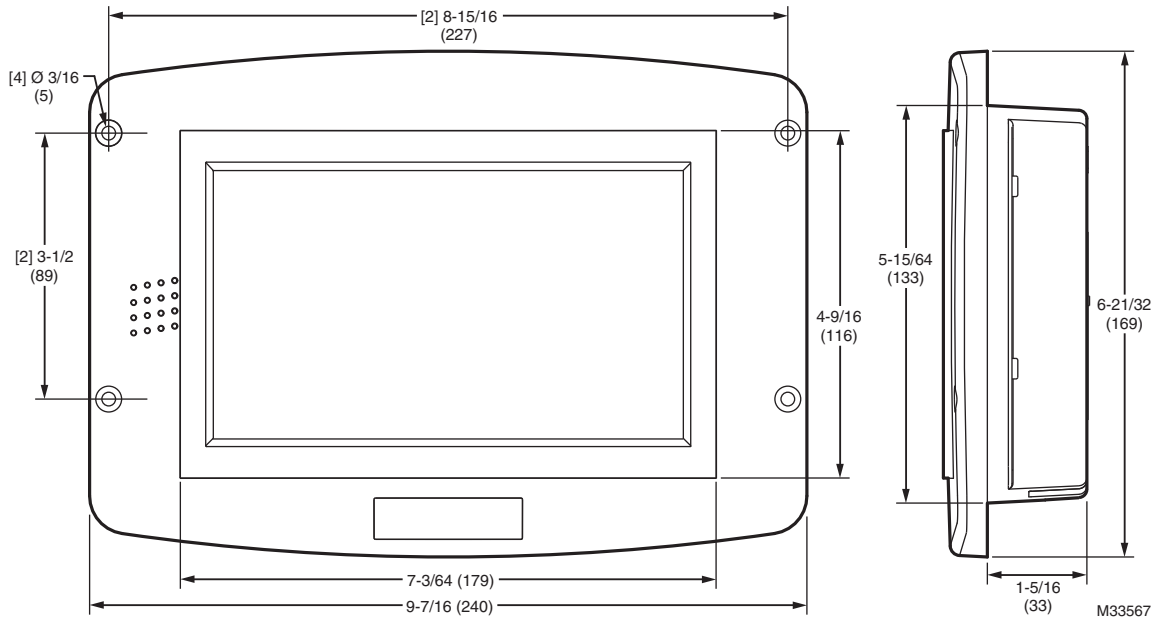

Fig. 16. S7999D dimensions in in. (mm).

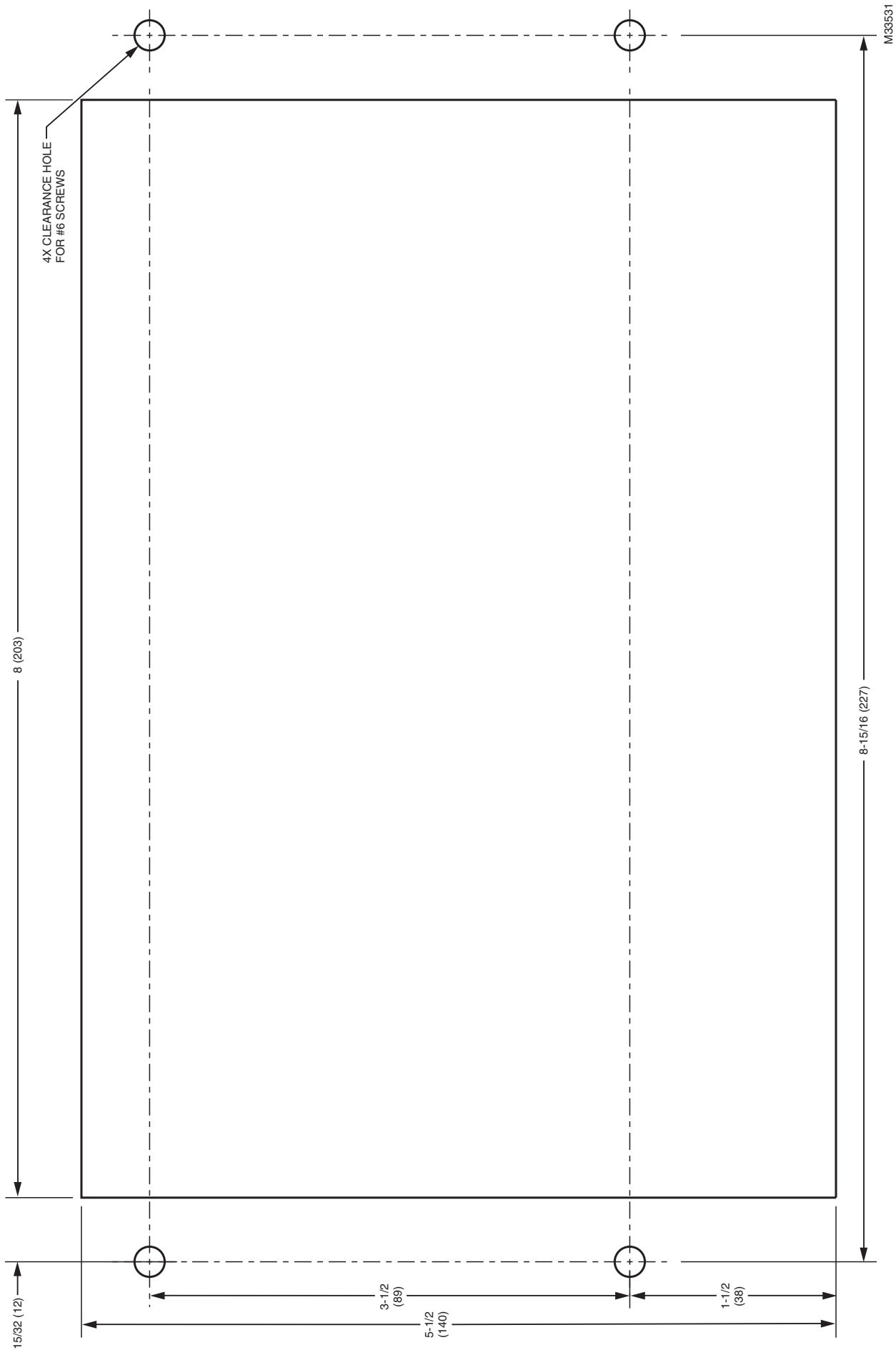

Fig. 17. S7999D front-mount cutout template.

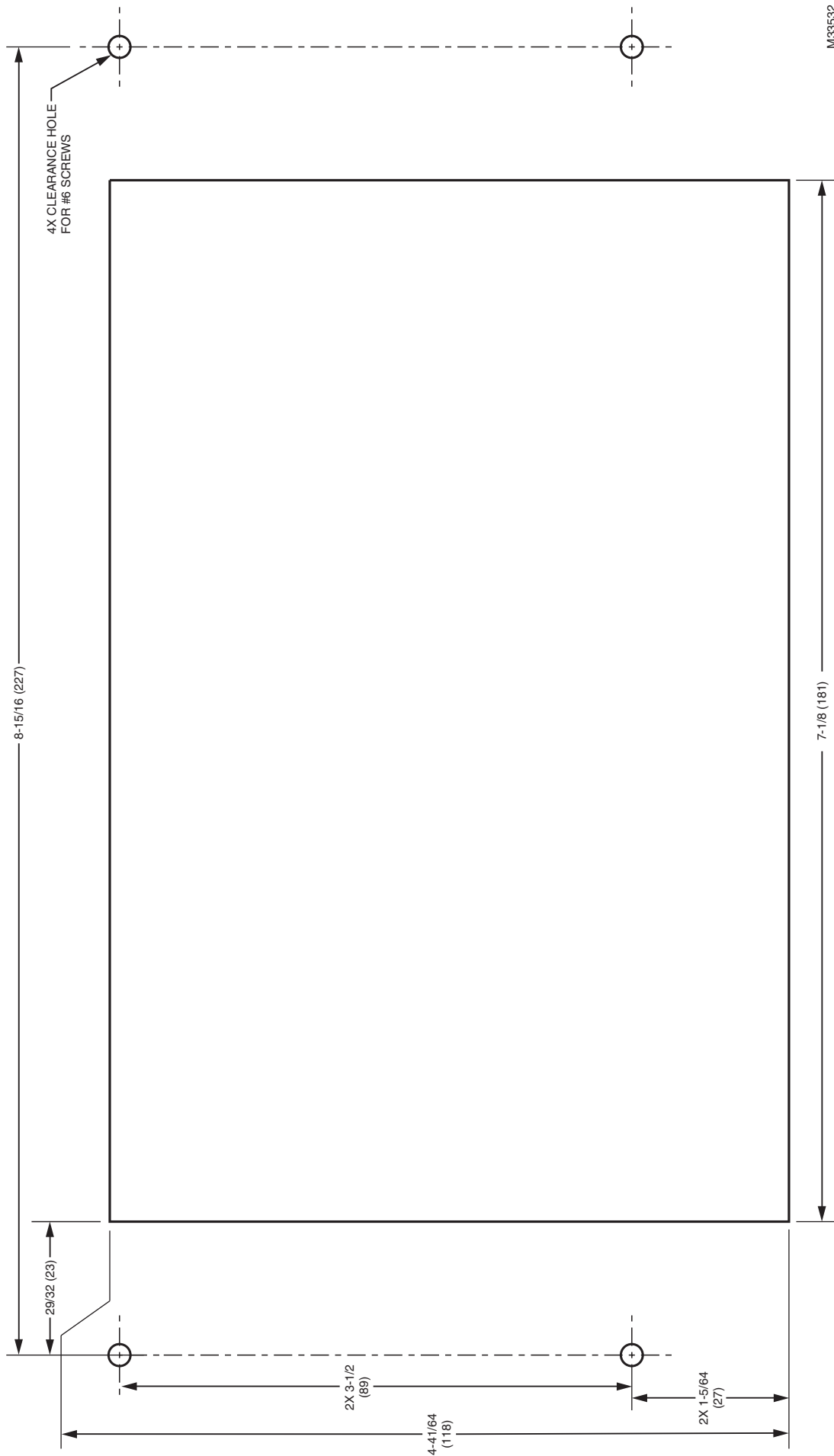

Fig. 18. S7999D rear-mount cutout template.

Automation and Control Solutions

Honeywell International Inc.
1985 Douglas Drive North
Golden Valley, MN 55422
customer.honeywell.com

© U.S. Registered Trademark
© 2012 Honeywell International Inc.
66-1200—01 M.S. 04-12
Printed in United States

Honeywell