

HS8/HS88 Series
January 6, 1986

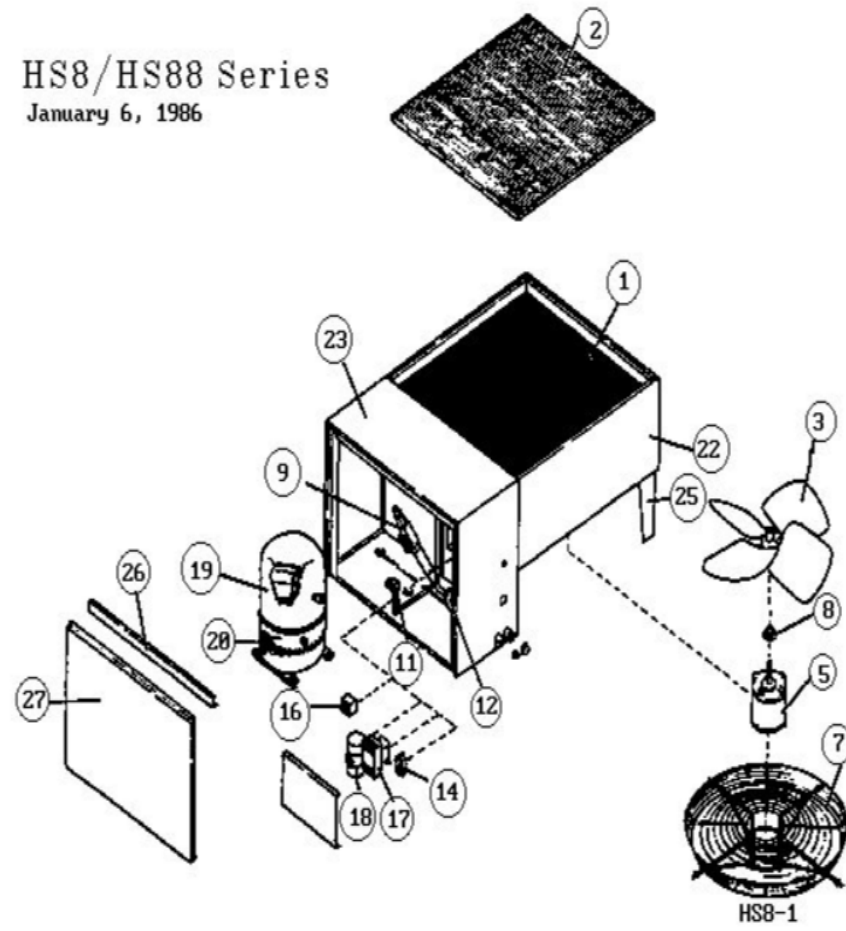

Revision Number - 4

CABINET PARTS

Callout	Name	Quantity	Description
	PANEL Cat #: LB-41720BC Model/Part #: LB-41720BC	1	ORIFICE PANEL W/MOUNTED LEGS
	COVER-CONTROL BOX Cat #: LB-60174 Model/Part #: LB-60174	1	COVER-CONTROL BOX
	BASE-COMPRESSOR Cat #: LB-8104 Model/Part #: LB-8104	1	COMPRESSOR
22	WRAPPER Cat #: 53483 Model/Part #: LB-41719BD	1	CONDENSER
23	WRAPPER-COMP Cat #: LB-8105C Model/Part #: LB-8105C	1	WRAPPER-COMP
25	LEG Cat #: 86627 Model/Part #: LB-8593D	2	ORIFICE PANEL
26	STRIP-TOP Cat #: LB-8111D Model/Part #: LB-8111D	1	STRIP-TOP
27	PANEL-ACCESS Cat #: LB-8109 Model/Part #: LB-8109	1	ACCESS

CONTROL PANEL PARTS

Callout	Name	Quantity	Description
17	CONTACTOR Cat #: 66441 Model/Part #: P-8-1454	1	"DPST,24V(230V UNITS)"
17	CONTACTOR Cat #: 38393 Model/Part #: P-8-7736	1	"3PDT,24V(208V- 1PH UNITS)"
18	CAPACITOR Cat #: 53H02 Model/Part #: P-8-1379	1	"5MFD,370VAC"

COOLING PARTS

Callout	Name	Quantity	Description
	HEATER-CRANKCASECOMP- INTERNAL(FOOTNOTE 1 Cat #: Model/Part #:	1	
	MOUNT PKG-COMP Cat #: 49A67 Model/Part #: 49A7001PR	1	49A7001PR COMP MT PK
	WASHER Cat #: P-8-5029 Model/Part #: P-8-5029	4	WASHER, 7/16 ID X 1.0 OD X .083 THK FLAT
	VALVE-SERVICE Cat #: 38401 Model/Part #: P-8-8467	1	"LIQUID,1/2""
	CAPACITOR-RUN Cat #: 38319 Model/Part #: P-8-8708	1	"35MFD,440VAC"
	PLUG-RUBBER Cat #: 86494 Model/Part #: P-8-8713	4	RUBBER
1	COIL-OUTDOOR Cat #: 8-6-7481B Model/Part #: 8-6-7481B	1	W/MANIFOLD
2	GUARD-COIL Cat #: 53660 Model/Part #: LB-43286BB	1	GUARD-OUTDOOR COIL
3	FAN Cat #: 61105 Model/Part #: P-8-8038	1	"1/2""BORE,20""DIA,4 BLADE"
5	MOTOR-FAN Cat #: 61106 Model/Part #: P-8-8041	1	"1/3HP,1050RPM,208- 230/60/1"
7	MOUNT-MOTOR Cat #: 86060 Model/Part #: P-8-8042	1	BRACKET
8	SHIELD-RAIN Cat #: 32621 Model/Part #: P-8-6142	1	SHIELD, MOTOR
9	VALVE-SERVICE Cat #: 55G00 Model/Part #: P-8-8472	1	"SUCTION,3/4""
12	DRIER Cat #: 68831 Model/Part #: P-8-8416	1	DRIER
19	COMPRESSOR Cat #: 72L45 Model/Part #: P-8-8785	1	"3TON,230/60/1,COPE"

Note:

Note1: SEE FIELD REPLACEMENT CRANKCASE HEATER CHART ON CRL CARD.