

# CMBE, CMBE TWIN

Horizontal, multistage centrifugal boosters

North America

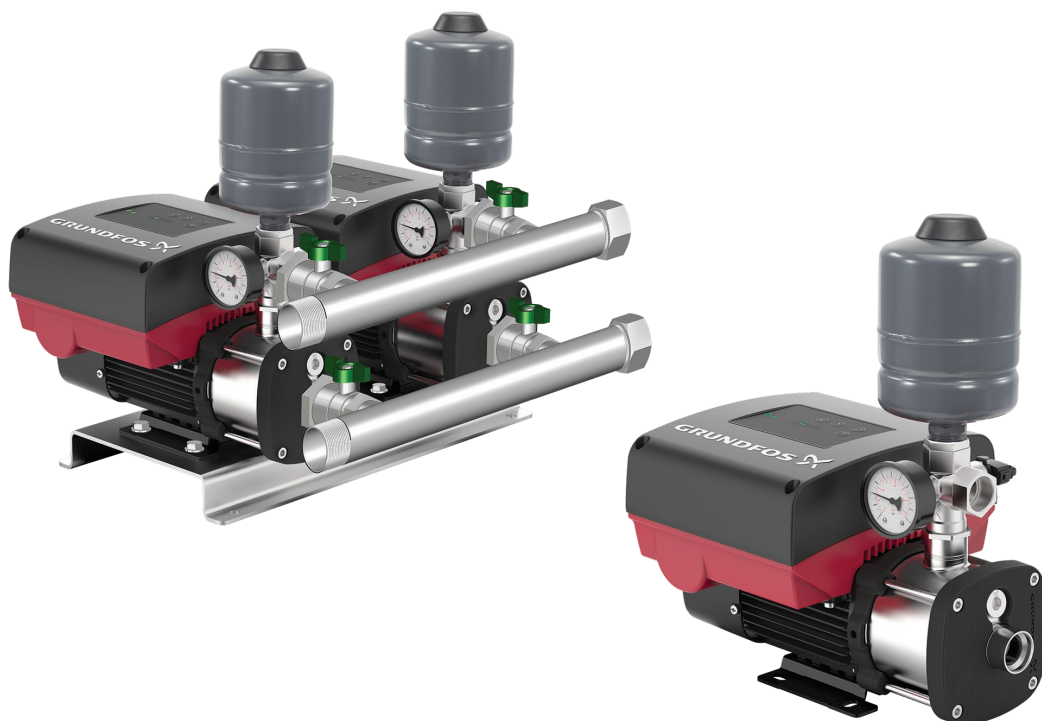

**1. Product introduction . . . . . 3**

    Applications . . . . . 3

    Pumped liquids . . . . . 3

    Identification . . . . . 4

    Standard operating panel . . . . . 6

    Operating conditions . . . . . 8

    Pressure . . . . . 8

    Materials . . . . . 8

    Approvals and markings . . . . . 8

    Performance range . . . . . 9

    Selection guide for residential applications . . . . . 10

    Mechanical installation . . . . . 11

    Electrical installation . . . . . 11

    Installation examples . . . . . 12

**2. CMBE . . . . . 14**

    Applications . . . . . 14

    Product description . . . . . 14

    Motor . . . . . 15

    Electrical data . . . . . 15

    Dimensions . . . . . 16

    Performance curves . . . . . 17

**3. CMBE TWIN . . . . . 18**

    Applications . . . . . 18

    Product description . . . . . 18

    Electrical data . . . . . 19

    Dimensions . . . . . 20

    Performance curve . . . . . 21

**4. Product numbers . . . . . 22**

**5. Grundfos Product Center . . . . . 23**

**6. Document quality feedback . . . . . 24**

# 1. Product introduction



CMBE

TM090441

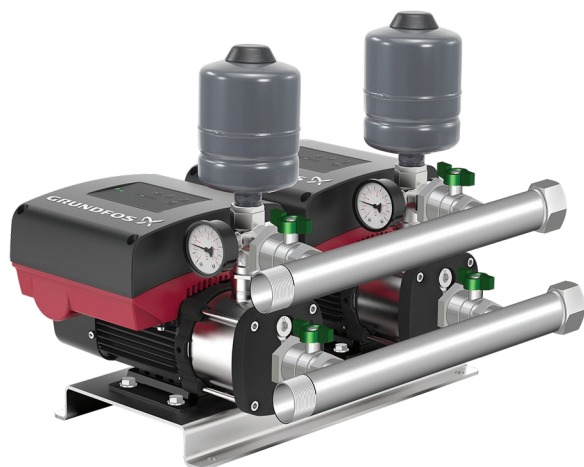

CMBE TWIN

TM090442

The compact Grundfos CMBE and CMBE TWIN boosters ensure optimal water pressure for domestic and commercial applications, such as clean-water and raw-water supply, pressure boosting, irrigation and dewatering.

Each pump is delivered complete with 5-way fittings, non-return valves, diaphragm tank, pressure sensor and pressure gauge.

CMBE features a variable-speed motor, enabling constant pressure, high comfort and noiseless operation. The built-in protection against dry running, overload and over temperature ensure long product life. CMBE consists of a Grundfos CME pump and a pressure control unit. The pressure control unit allows the pump to start and stop automatically according to demand.

CMBE TWIN has two CMBE pumps that operate in parallel. The two pumps are mounted on a common base plate. Both pumps run when there is need for a higher flow to maintain a constant pressure.

## Applications

The pumps are designed to cover a wide range of applications from domestic installations to small commercial applications.

Typical applications for CMBE:

- pressure boosting for home and gardening
- water supply for agriculture and irrigation
- transfer and pressure boosting from break tank and rainwater applications.

Typical applications for CMBE TWIN:

- apartment buildings
- hospitals, hotels and small industrial plants
- domestic fire suppression.

## Pumped liquids

The product is suitable for pumping clean, thin, non-aggressive and non-explosive liquids without solid particles or fibres. Examples:

- drinking or tap water
- rainwater and condensate
- groundwater
- river and lake water
- boiler feed water and district heating water
- chlorinated water
- softened water
- washing and cleaning.

The product must not be used for transfer of diesel oil or other oil-containing liquids. Sand and other impurities in the water can cause wear to the product.

## Identification

### Type key example

**Note:** The type key cannot be used for ordering as not all combinations are possible.

Example: CMBE 10-54 I-U-C-E-D-G

Code	Designation	Explanation
CMBE TWIN	CMBE TWIN Booster with cascade control and pump alternation	Type range
CMBE	CMBE Booster with integrated frequency converter	
10		Rated flow rate [m <sup>3</sup> /h]
- 54		Max. head [m]
I	Sleeve - EN 1.4301/AISI 304 Pump shaft - EN 1.4301/AISI 304 Impellers/chambers - EN 1.4301/AISI 304 Pressure sensor - Corrosion-resistant coating, PPS, EPDM or FKM fitting ISO 7/1-R1/2" and NPT 1/2", EN 1.4408 AISI 316 Pressure tank - EPDM/steel/PP/Butyl 5-way valve - EN 1.4301/AISI 304	Materials in contact with the pumped liquid
U	1 × 200-240 V, 50/60 Hz	Supply voltage [V]
X	1 × 110-115 V, 60 Hz	
C	High-efficiency motor with variable frequency drive (IP55)	Motor
B	4.9 ft (1.5 m) cable with US plug <sup>1)</sup>	Main cable and plug
E	No cable or plug	
D	Integrated variable frequency drive	
E	NPT 1	Thread
G	NPT 1 1/2	
H	NPT 2	

<sup>1)</sup> CMBE has 4.9 ft (1.5 m) cable with US plug. CMBE TWIN is for fuse box connection and has 15 ft (4.5 m) cable (no plug).

Nameplate example, CMBE

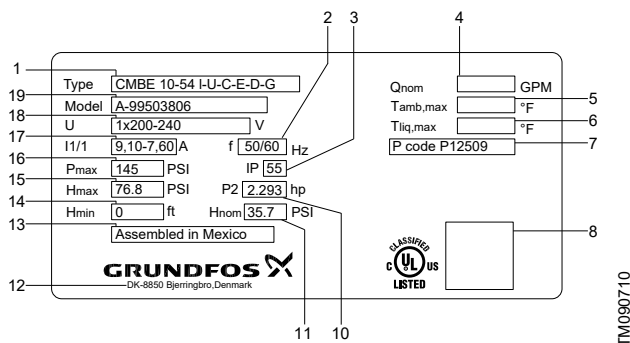

Pos.	Description
1	Product type
2	Frequency
3	IP class
4	Nominal flow rate [gpm]
5	Max. ambient temperature [(°F)]
6	Max. liquid temperature [(°F)]
7	EFF
8	QR code
9	Approvals
10	Power input [hp]
11	Nominal head [psi]
12	Manufacturer
13	Country of origin
14	Min. head [psi]
15	Max. head [psi]
16	Max. system pressure [psi]
17	Full load Amps
18	Supply voltage
19	Model

Related information

[Recommended setpoint](#)

Nameplate example, CMBE TWIN



Pos.	Description
1	Manufacturer
2	Product type
3	Product number and serial number
4	Model
5	Supply voltage
6	Max. system pressure [psi]
7	Liquid temperature [°F]
8	Control panel product number
9	Net weight
10	Country of origin
11	QR code
12	Approvals
13	Nominal head/Max. nominal head
14	Nominal flow rate/Max. nominal flow rate [gpm]
15	Production code

Related information

[Recommended setpoint](#)

## Standard operating panel

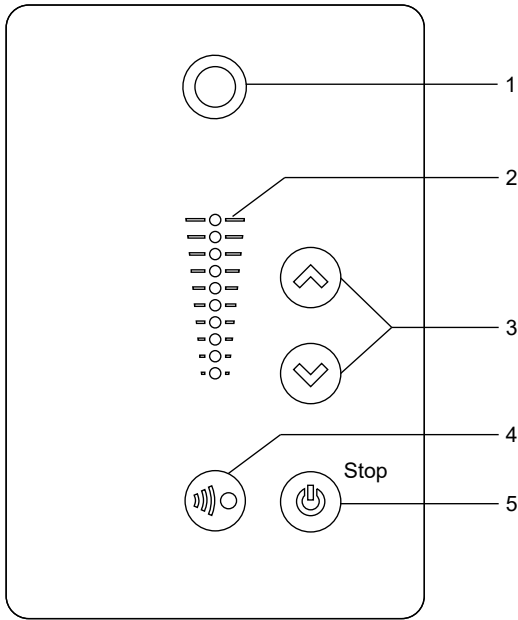

TM054848

Pos.	Symbol	Description
1		<b>Grundfos Eye:</b> The indicator light shows the operating status of the product.
2	-	Light fields for indication of the setpoint
3		<b>Up/Down:</b> The buttons change the setpoint.
4		<b>Radio communication:</b> The button enables radio communication with the Grundfos GO and other products of the same type.
5		<p><b>Start/Stop:</b> Press the button to make the product ready for operation or to start and stop the product.</p> <p><b>Start:</b> If you press the button when the product is stopped, the product starts if no other functions with higher priority have been enabled.</p> <p><b>Stop:</b> If you press the button when the product is running, the product always stops. When you press the button, the stop icon appears at the bottom of the display.</p>

## Recommended setpoint

The desired setpoint of the pump is set by pressing the up and down buttons. The light fields on the operating panel will indicate the chosen setpoint.

The following example applies to a pump in an application where a pressure sensor gives feedback to the pump. If the sensor is retrofitted to the pump, it must be set up manually as the pump does not automatically register a connected sensor. The figure below shows that the light fields 5 and 6 are activated, indicating a desired setpoint of 72.5 psi (5 bar) with a sensor measuring range from 0 to 145 psi (0 to 10 bar). The setting range is equal to the sensor measuring range.

The setpoint must not be set higher than the maximum head of the pump. Refer to the nameplate for the maximum head

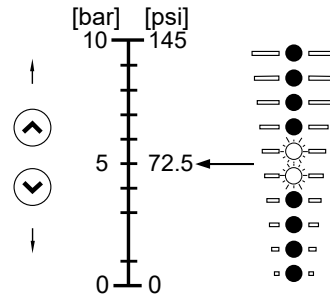

TM060692

## Related information

[Nameplate example, CMBE](#)

[Nameplate example, CMBE TWIN](#)

### Grundfos GO

The product is designed for wireless radio communication with Grundfos GO.

Grundfos GO enables you to set functions and gives you access to status overviews, technical product information and current operating parameters.

Use Grundfos GO together with the following mobile interface:

Grundfos MI 301.

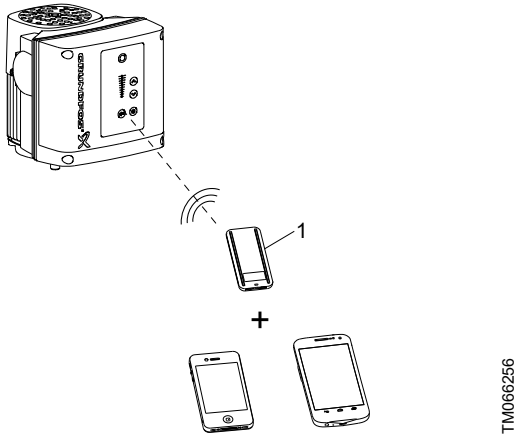

---

**Pos. Description**

Grundfos MI 301 is a separate module enabling radio communication.

- 1 Use the module together with an Android or iOS-based smart device via a Bluetooth connection.
- 

To learn more about MI 301, use your smart device to scan the QR codes below:

**Grundfos MI 301 Installation and operating instructions**



QR\_92555648

**Grundfos MI 301 Quick guide**



QR\_98133720

---

## Operating conditions

System pressure	Max. 145 psi (10 bar) (1 MPa)
Suction lift	Max. 3.28 ft (1 m), including suction-pipe pressure loss at a liquid temperature of 68 °F (+20 °C)
Min./max. operating temperature	-4 °F to 122 °F (-20/+50 °C) <sup>2)</sup>
Liquid temperature	32-140 °F (0-60 °C)
Max. ambient temperature	131 °F (+55 °C)
Min. ambient temperature	-4 °F/ (-20 °C)
Relative humidity	Max. 95 %
Enclosure class	Pump: IP55 Pressure sensor IP54
Insulation class	F
Sound pressure level	≤ 55 dB(A) <sup>3)</sup>
Supply voltage	1 × 115 V, 60 Hz 1 × 200-240 V, 60 Hz
Start/stop frequency	Max. 100 per hour
Cut-in pressure	7.25 psi (0.5 bar) below setpoint

<sup>2)</sup> The motor can operate with the rated power output (P<sub>2</sub>) at 122 °F (50 °C), but continuous operation at higher temperatures reduces the expected product life. If the motor is to operate at ambient temperatures between 122 °F (50 °C) and 140 °F (60 °C), an oversized motor must be selected. Contact Grundfos for further information.

<sup>3)</sup> For CMBE TWIN, the sound pressure level may be higher.

## Pressure

Designation	psi	[bar]	[MPa]
Min. inlet pressure (relative) without pressure sensor	Observe local regulations.		
Min. inlet pressure with pressure sensor	Observe local regulations.		
Max. outlet pressure	145	10	1
Max. operating pressure	145	10	1

## Materials

Designation	Material
Terminal box	Composite PC/ASA and silumin (Alu)
Stator housing	Silumin (Alu)
Fan cover	Composite PBT/PC
Pump housing	Stainless steel, EN 1.4301/AISI 304
Shaft and impeller	Stainless steel, EN 1.4301/AISI 304
Flange	Cast iron

## Approvals and markings

### Drinking water approval



TM076608

UL electrical:

1 × 230 V CMBE models: UL listed packaged pumping system.

### Wetted parts



TM057110

Designation	Material	Technical description
Pump sleeve	Stainless steel	AISI 304 / EN 1.4301
Impeller	Stainless steel	AISI 304 / EN 1.4301
Diffuser	Technopolymer	PP 20 % Talc
Ejector	Technopolymer	PPE/PS 20 % GF
Nozzle	Stainless steel	AISI 304 / EN 1.4301
Shaft	Stainless steel	AISI 304 / EN 1.4301
Shaft seal	Carbon with resin/ ceramic	CVBP
Filling plug	Technopolymer	PES 30 % GF
Drain plug	Technopolymer	PES 30 % GF
Pressure sensor	Corrosion-resistant coating, PPS, EPDM or FKM fitting	ISO 7/1-R1/2" and NPT 1/2", EN 1.4408 AISI 316

Performange range

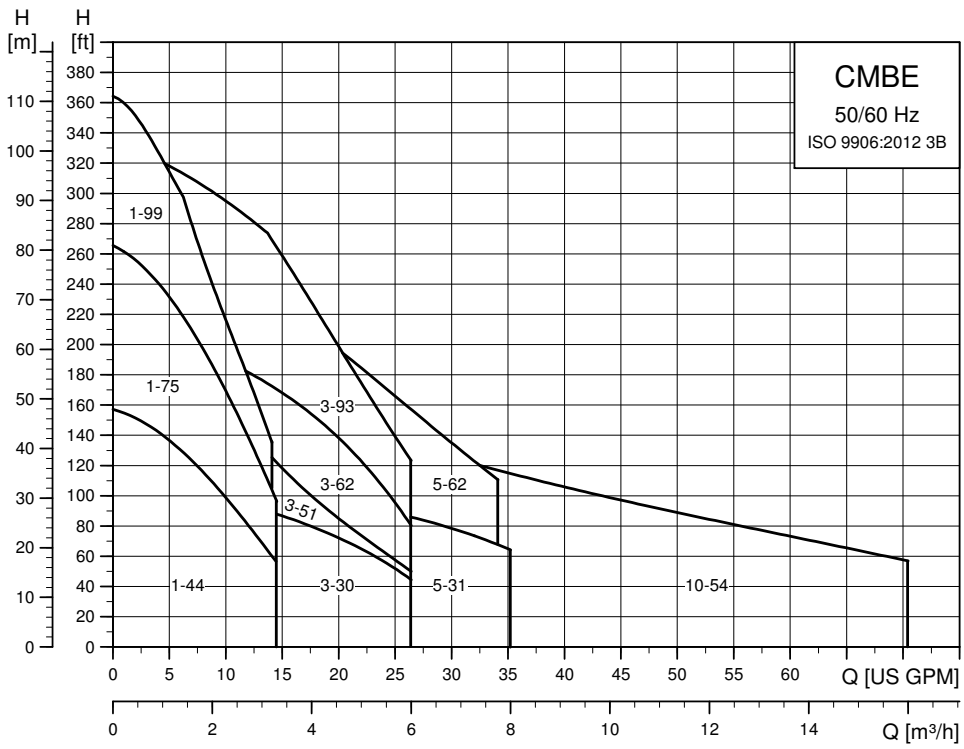

TM090716

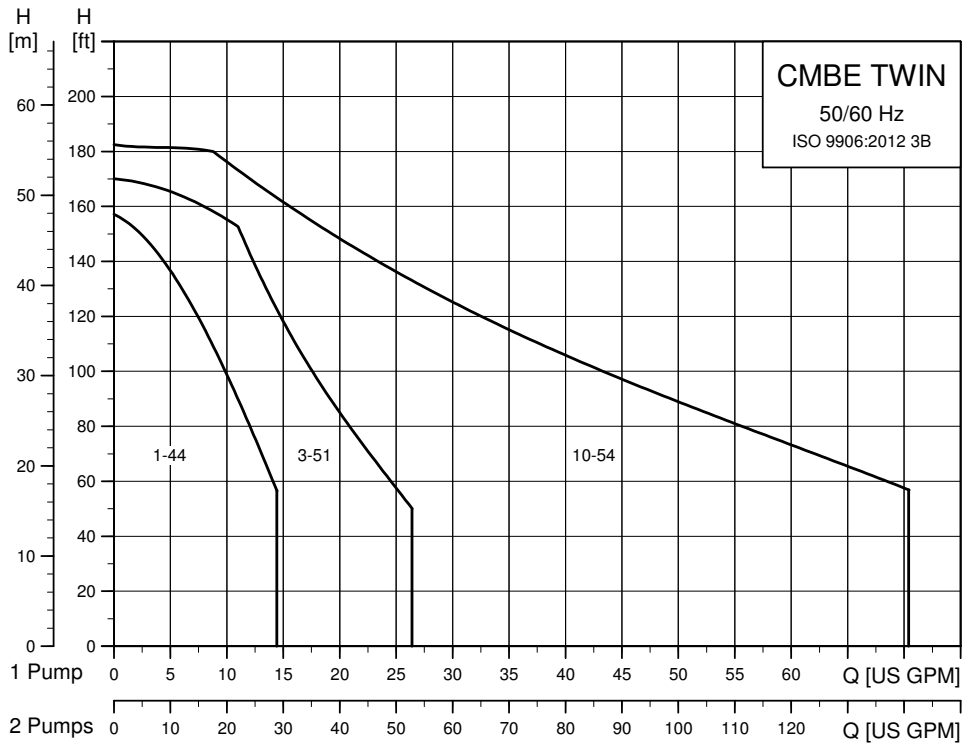

TM090715

## Selection guide for residential applications

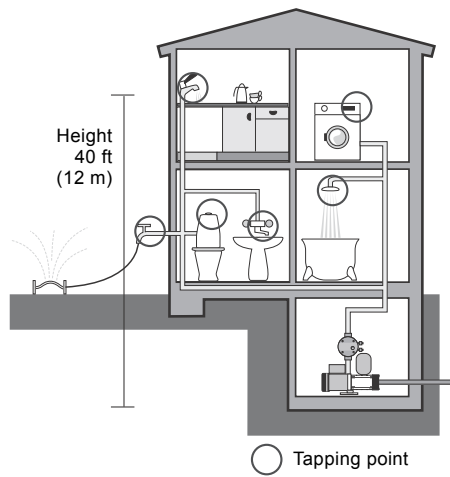

Number of floors	1-5 taps	6-10 taps	11-20 taps	21-50 taps
4	CMBE 1-75	CMBE 1-75	CMBE 3-62	CMBE 3-93
3	CMBE 1-44	CMBE 1-75	CMBE 3-62	CMBE 3-62
2	CMBE 1-44	CMBE 1-44	CMBE 3-62	CMBE 3-62
1	CMBE 1-44	CMBE 1-44	CMBE 3-30	CMBE 3-62

### A: Required comfort level

- Adjustable constant pressure.

### B: Find the right booster

- How many taps? 6.
- How many floors? 3.

**Result: CMBE 1-75**

TM090724

### Sizing and selection example

## Charts for selecting supply power flow rates

### 1 × 230 V

PSI boost	0-15 gpm	0-25 gpm	0-30 gpm	0-45 gpm	0-55 gpm	0-65 gpm
20	CMBE 1-44	CMBE 3-30	CMBE 5-31	CMBE 10-54	CMBE 10-54	CMBE 10-54
25	CMBE 1-44	CMBE 3-30	CMBE 5-31	CMBE 10-54	CMBE 10-54	CMBE 10-54
30	CMBE 1-75	CMBE 5-31	CMBE 5-31	CMBE 10-54	CMBE 10-54	CMBE 10-54
35	CMBE 1-75	CMBE 3-62	CMBE 5-31	CMBE 10-54	CMBE 10-54	-
40	CMBE 1-75	CMBE 3-62	CMBE 5-62	CMBE 10-54	-	-
45	CMBE 1-75	CMBE 3-62	CMBE 5-62	CMBE 10-54	-	-
50	CMBE 1-99	CMBE 3-62	CMBE 5-62	-	-	-
55	CMBE 1-99	CMBE 3-93	CMBE 5-62	-	-	-
60	CMBE 1-99	CMBE 3-93	CMBE 5-62	-	-	-
65	CMBE 1-99	CMBE 5-62	-	-	-	-
70	CMBE 3-93	CMBE 5-62	-	-	-	-
75	CMBE 3-93	CMBE 5-62	-	-	-	-
80	CMBE 3-93	CMBE 5-62	-	-	-	-

### 1 × 115 V

PSI boost	0-10 gpm	0-15 gpm	0-20 gpm
20	CMBE 1-44	CMBE 1-44	CMBE 3-30
25	CMBE 1-44	CMBE 3-30	CMBE 3-30
30	CMBE 1-44	CMBE 3-30	CMBE 3-51
35	CMBE 1-44	CMBE 3-51	CMBE 3-51 <sup>4)</sup>
40	CMBE 1-44	CMBE 3-51	-
45	CMBE 1-44	CMBE 3-51	-
50	CMBE 1-75	CMBE 3-51	-
55	CMBE 1-75 <sup>4)</sup>	-	-
60	CMBE 1-75 <sup>4)</sup>	-	-

<sup>4)</sup> Indicated pump may be 5-10 % undersized on flow at desired pressure.

### Mechanical installation

Placing the pump above ground offers a convenient solution for establishing a reliable water or rainwater supply. For optimal performance, several installation considerations are recommended.

- Locate the pump close to the water supply to minimize the length of the inlet pipe. This can enhance efficiency and reduce suction loss.
- Use a non-collapsible hose to maintain consistent flow when using a hose as the inlet pipe. A strainer at the inlet end helps prevent solid particles from entering the pump.
- Place the pump on a flat, stable surface. Proper fixation helps prevent displacement during startup and operation. The inlet connection must be oriented horizontally.
- Install the pump so that inspection, maintenance and service are easily performed.
- Installed the pump in a well-ventilated location. For outdoor installations, a protective cover is required. The cover must be large enough to shield the motor from direct sunlight, rain, and snow.
- Installed the inlet pipe in such a way that bends, airlocks and any unnecessary restrictions to the flow are avoided. See the figure below.

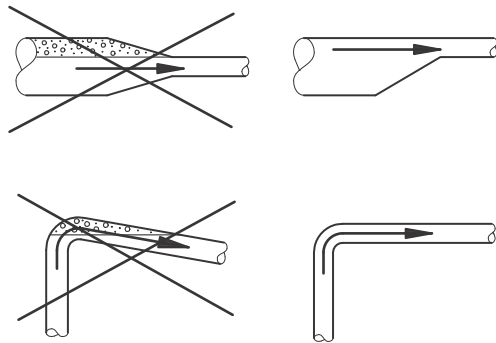

TM090717

#### Pipe recommendations

Long inlet pipes affect the performance of the pump. The diameter of the inlet pipe must not be smaller than that of the inlet port

### Electrical installation

The electrical connection and protection must be carried out in accordance with local regulations.

The pump must be connected to an external main switch with a minimum contact gap of 0.1 in (3 mm) in all poles.

Make sure that the pump is suitable for the power supply to which it is to be connected.

The pump and pressure control unit must always be correctly grounded.

Single-phase CMBE requires no external motor protection.

The variable-speed motor incorporates thermal protection against slow overloading and blocking.

## Installation examples

We recommend that you follow the installation examples.

Valves are not supplied with the pump.

### Flooded suction from a tank

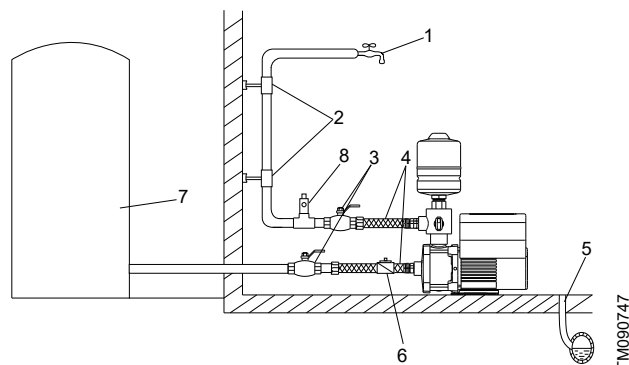

*Flooded suction from a tank*

Pos.	Description
1	Highest tapping point
2	Pipe hangers
3	Isolating valves
4	Flexible hoses
5	Drain to sewer
6	Non-return valve
7	Freshwater tank
8	Optional pressure-relief valve on the outlet side if the pressure can exceed 10 bar (145 psi).

### Mains water pressure boosting

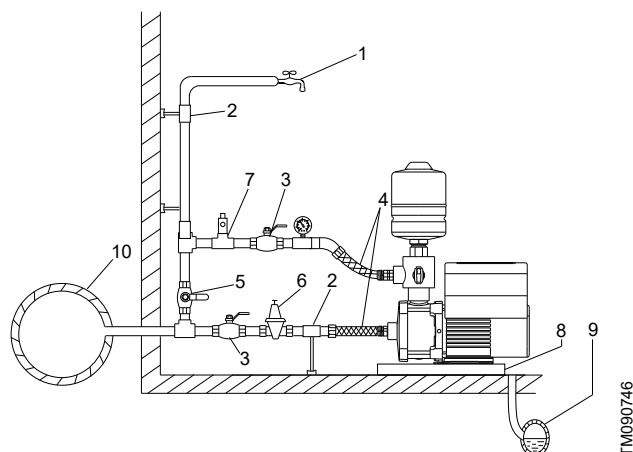

Pos.	Description
1	Highest tapping point
2	Pipe hangers and supports
3	Isolating valves
4	Flexible hoses
5	Bypass valve
6	Optional pressure-reducing valve on the inlet side.
7	Optional pressure-relief valve on the outlet side if the pressure can exceed 10 bar (145 psi).
8	Install the pump on a small stand to prevent the ventilation holes from being flooded.
9	Drain to sewer
10	Mains water pipe

**Thermal expansion**

When using the product in installations with water heaters, you must use a non-return valve, pressure-relief valve or a thermal expansion tank between pump and the water heater. This prevents the backflow pressure from exceeding the 10 bar pressure limit the pump is designed for.

When water is heated in a closed-loop system, its volume increases. A thermal expansion tank is most often used to absorb the additional volume created by this process.

Always consult the applicable water heater manufacturer specifications as installations may vary.

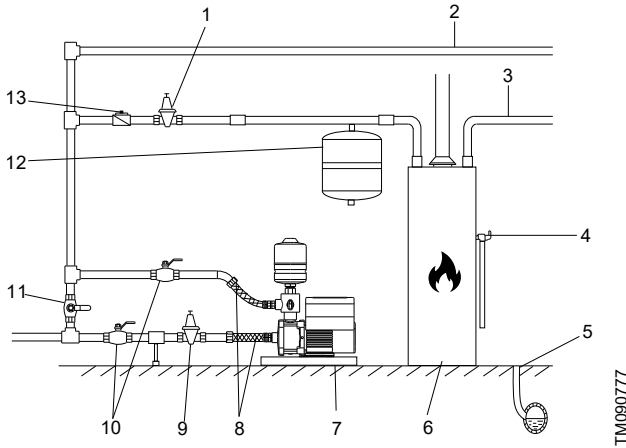

*Installation example*

Pos.	Description
1	Pressure-relief valve (optional)
2	Cold water
3	Hot water
4	Temperature and pressure valve
5	Drain to sewer
6	Water heater
7	Install the pump on a small stand to prevent the ventilation holes from being flooded.
8	Flexible hoses
9	Optional pressure-reducing valve on the inlet side if the pressure can exceed 10 bar (145 psi).
10	Isolating valves
11	Bypass valve
12	Expansion tank
13	Non-return valve

## 2. CMBE



TM090441

### Applications

The compact Grundfos CMBE Booster is suitable for clean water supply and pressure boosting in domestic and light commercial applications.

The CMBE Booster keeps a constant pressure in the pipe system and is mainly used in places such as:

Application	CMBE 1	CMBE 3	CMBE 5	CMBE 10
Single-family houses	●	●	○	○
Two-family houses	○	●	●	●
Cluster homes		●	●	●
Blocks of flats		●	●	●
Schools		●	●	●
Small hotels/guest houses		●	●	●
Small office buildings		●	●	●
Agriculture		○	●	●
Irrigation		○	●	●

● Recommended

○ Applicable

### Product description

The Grundfos CMBE booster is a compact booster system for water supply in domestic applications. The integrated speed controller enables the CMBE booster to keep constant pressure in the pipe system. A pressure sensor monitoring changes in the water consumption signals the speed controller to change motor speed to adapt performance to the new state.

The CMBE booster is very easy to install. When the system has been connected to the pipes, it is all a matter of inserting the plug into a power supply socket, and the system is operational.

The CMBE booster consists of the following:

- CME pump with integrated frequency converter
- five-way valve
- expansion tank (green or grey depending on the local drinking water legislation)
- outlet pressure gauge
- outlet pressure sensor

The Grundfos CMBE booster requires no external motor protection.

The MGE motor incorporates thermal protection against slow overloading and blocking (IEC 34.11: TP 211).

The Grundfos CMBE booster is mainly used for domestic and light commercial water supply or booster systems.

Suction lift: maximum 1 m, including inlet pipe pressure loss at a liquid temperature of 20 °C (not self-priming).

### CMBE components

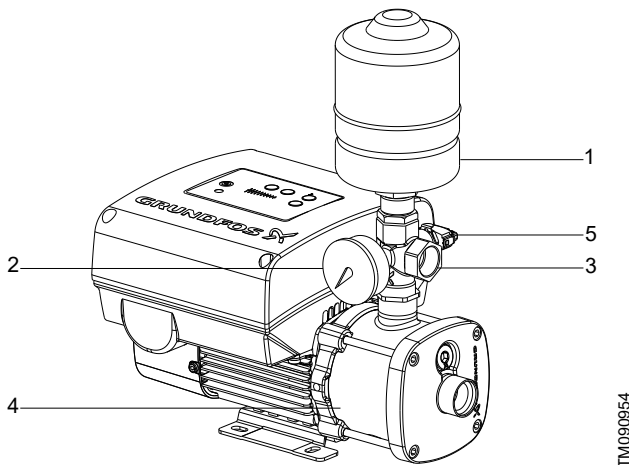

TM090954

Pos.	Description
1	Diaphragm tank
2	Pressure gauge
3	Five-way fitting with integrated non-return valve
4	CMBE pump
5	Pressure sensor

### Motor

No external motor protection is required. The MGE motor incorporates thermal protection against slow overloading and blocking (TP 211 according to IEC 34.11).

### Features

- Premium efficiency IE5 motors
- constant pressure, integrated speed control
- resistant to corrosion
- frequency controller: Up to 40 % energy savings
- compact and fully equipped
- low noise level: 55 dB(A)
- user-friendly interface with LED indicators
- dry-running protection
- thermal overload protection: built-in thermal protection
- easy installation.

### Constant pressure

The integrated speed controller keeps a constant pressure in the pipe system. A pressure sensor monitors changes in the water consumption and signals to the speed controller to adjust the motor speed up or down.

### Dry-running protection

Dry-running protection is very important as dry running may damage the bearings and shaft seals. The inlet pressure of the system or the water level in a possible tank on the inlet side is monitored. Lack of inlet pressure or water shortage is indicated by the motor speed. When dry running is detected, the CMBE Booster will stop and go into alarm mode. The pump will attempt 5 restarts at 10 second intervals. If there is no water shortage, it will attempt 8 restarts at 5 minute intervals. If this is not successful, the cycle will be repeated after 24 hours.

### Easy installation

The booster is easy to install. When the booster has been connected to the pipes, it is all a matter of plugging the plug into a socket, and the system is operational.

Please ensure that you follow the relevant codes of practice for drinking water installations.

### Electrical data

#### CMBE 1 × 200-240 V

Pump type	Max. rated current [A]	P1 [HP]	P1 [W]
CMBE 1-44	3.5	0.825	615
CMBE 1-75	6.7	1.338	998
CMBE 1-99	6.7	1.676	1250
CMBE 3-30	6.7	0.917	684
CMBE 3-62	6.7	1.623	1210
CMBE 3-93	9.1	2.307	1720
CMBE 5-31	6.7	1.462	1090
CMBE 5-62	9.1	2.307	1720
CMBE 10-54	9.1	2.293	1710

#### CMBE 1 × 115 V

Pump type	Max. rated current [A]	P1 [HP]	P1 [W]
CMBE 1-44	8.0	0.838	625
CMBE 1-75	8.0	1.338	998
CMBE 3-30	8.0	0.878	655
CMBE 3-51	8.0	1.176	877

## Dimensions

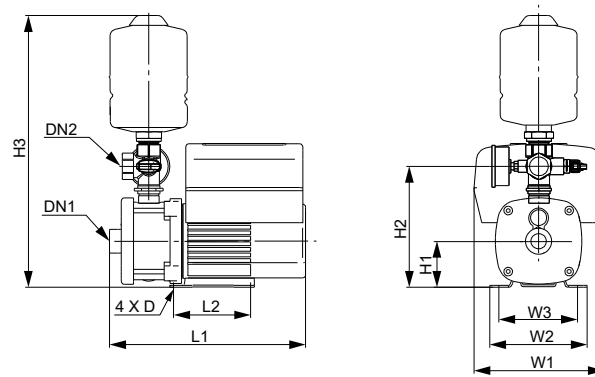

TM083212

Pump type	L1 [inch] [mm]	L2 [inch] [mm]	W1 [inch] [mm]	W2 [inch] [mm]	W3 [inch] [mm]	H1 [inch] [mm]	H2 [inch] [mm]	H3 [inch] [mm]	D [inch] [mm]	DN1	DN2
CMBE 1-44	12.83 (326)	3.74 (95)	8.54 (217)	6.22 (158)	4.92 (125)	2.95 (75)	7.87 (200)	17.32 (440)	0.4 (10)	1 NPT	1 NPT
CMBE 1-75	12.83 (326)	3.74 (95)	8.54 (217)	6.22 (158)	4.92 (125)	2.95 (75)	7.87 (200)	17.32 (440)	0.4 (10)	1 NPT	1 NPT
CMBE 1-99	15.66 (398)	3.74 (95)	8.54 (217)	6.22 (158)	4.92 (125)	2.95 (75)	7.87 (200)	17.32 (440)	0.4 (10)	1 NPT	1 NPT
CMBE 3-30	12.83 (326)	3.74 (95)	8.54 (217)	6.22 (158)	4.92 (125)	2.95 (75)	7.87 (200)	17.32 (440)	0.4 (10)	1 NPT	1 NPT
CMBE 3-51	12.83 (326)	3.74 (95)	8.54 (217)	6.22 (158)	4.92 (125)	2.95 (75)	7.87 (200)	17.32 (440)	0.4 (10)	1 NPT	1 NPT
CMBE 3-62	13.54 (344)	3.74 (95)	8.54 (217)	6.22 (158)	4.92 (125)	2.95 (75)	7.87 (200)	17.32 (440)	0.4 (10)	1 NPT	1 NPT
CMBE 3-93	15.90 (404)	4.92 (125)	8.54 (217)	7.01 (178)	5.82 (148)	3.54 (90)	8.46 (215)	17.91 (455)	0.4 (10)	1 NPT	1 NPT
CMBE 5-31	12.83 (326)	3.74 (95)	8.54 (217)	6.22 (158)	4.92 (125)	2.95 (75)	7.87 (200)	17.32 (440)	0.4 (10)	1 NPT	1 1/4 NPT
CMBE 5-62	13.77 (350)	4.92 (125)	8.54 (217)	7.00 (178)	5.82 (148)	3.54 (90)	8.46 (215)	17.91 (455)	0.4 (10)	1 NPT	1 1/4 NPT
CMBE 10-54	14.84 (377)	4.92 (125)	9.13 (232)	7.00 (178)	5.82 (148)	3.62 (92)	9.96 (253)	20.07 (510)	0.4 (10)	1 1/2 NPT	1 1/2 NPT

Performance curves

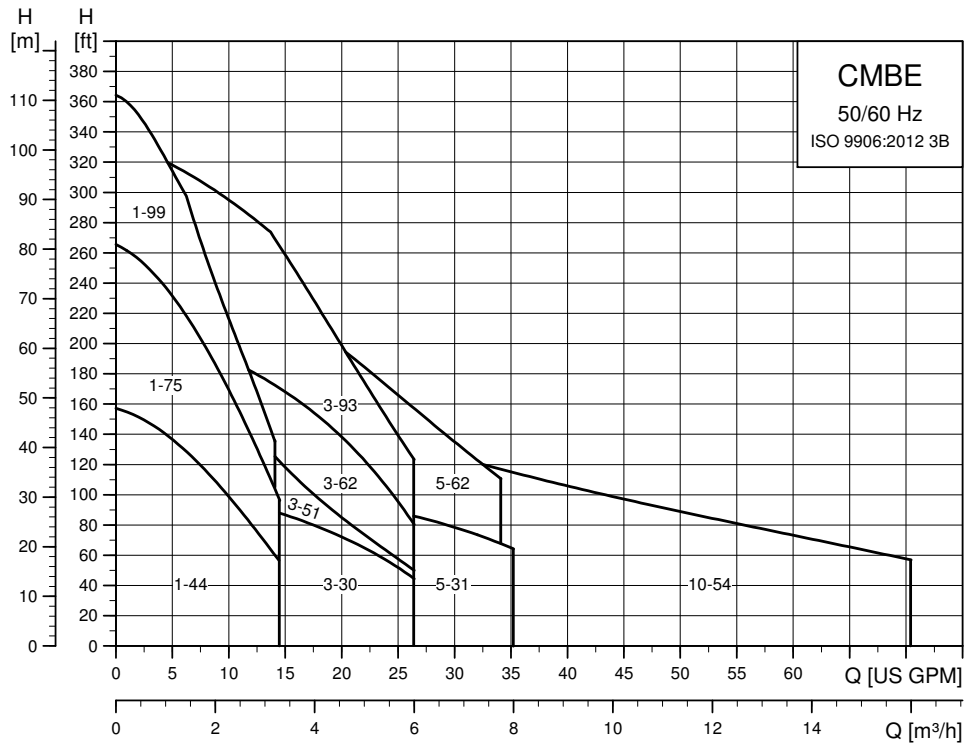

TM090716

## 3. CMBE TWIN

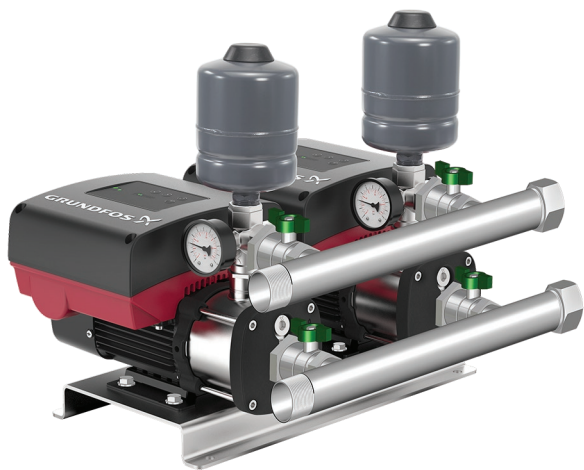

TM090442

### Applications

The compact Grundfos CMBE TWIN Booster is suitable for clean water supply and pressure boosting in domestic and commercial applications. The CMBE TWIN Booster keeps a constant pressure in the pipe system and is mainly used in places such as:

- two-family houses
- cluster homes
- blocks of flats
- schools
- small hotels
- small office buildings
- small industrial plants and businesses
- hospitals
- agriculture and irrigation.

### Product description

The CMBE TWIN system consists of two CMBE pumps connected in parallel and mounted on a common base plate with a manifold set. Each CMBE pump includes a Grundfos integrated variable frequency drive (VFD). Each CMBE pump is delivered complete with 5-way fittings, non-return valves, diaphragm tank, pressure sensor and pressure gauge.

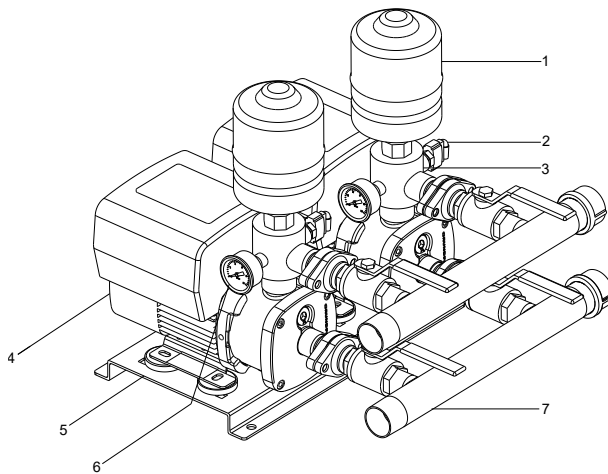

TM090713

Pos.	Description
1	Diaphragm tank
2	Pressure sensor
3	5-way fitting with integrated non-return valve
4	CME pump
5	Base plate
6	Pressure gauge
7	Inlet/outlet pipes with ball valves and unions (manifold set)

### Motor

No external motor protection is required. The MGE motor incorporates thermal protection against slow overloading and blocking (TP 211 according to IEC 34.11).

**Features**

- Constant pressure via integrated speed control
- cascade control and pump alternation
- dry-running protection
- compact
- robust, stainless-steel design
- easy installation
- low energy consumption
- noise level < 55 dB(A) and even lower at controlled speed.

**Constant pressure**

The integrated speed controller keeps a constant pressure in the pipe system. A pressure sensor monitors changes in the water consumption and signals to the speed controller to adjust the motor speed up or down.

**Cascade control**

Cascade control ensures that the performance of the booster system is automatically adapted to the consumption by switching pumps on or off and by changing the speed of the pumps in operation. The system runs as energy-efficiently as possible with a constant pressure and only the number of pumps required.

**Pump alternation**

Pump alternation ensures that the operating hours are distributed evenly on the pumps over time. CMBE TWIN Booster automatically alternates the pumps and will start the available pump with the lowest number of running hours since the last time the power was switched off.

**Dry-running protection**

Dry-running protection is very important as dry running may damage the bearings and shaft seals. The inlet pressure of the system or the water level in a possible tank on the inlet side is monitored. Lack of inlet pressure or water shortage is indicated by the motor speed. When dry running is detected, the CMBE Booster will stop and go into alarm mode. The pump will attempt 5 restarts at 10 second intervals. If there is no water shortage, it will attempt 8 restarts at 5 minute intervals. If this is not successful, the cycle will be repeated after 24 hours.

**Easy installation**

The booster is easy to install. When the booster has been connected to the pipes, it is all a matter of plugging the plug into a socket, and the system is operational.

Please ensure that you follow the relevant codes of practice for drinking water installations.

**Electrical data**

The values below are for one-pump operation.

Pump type	Supply voltage 60 Hz	Max. rated current [A]	P1 max [HP]	P1 max [W]
CMBE TWIN 1-44	1 × 115 V	8.0	0.838	625
CMBE TWIN 3-51	1 × 115 V	8.0	1.176	877
CMBE TWIN 10-54	1 × 200-240 V	9.1	2.293	1710

Plug type: CMBE TWIN is for fuse box connection and has 15 ft (4.5 m) cable and no plug.

## Dimensions

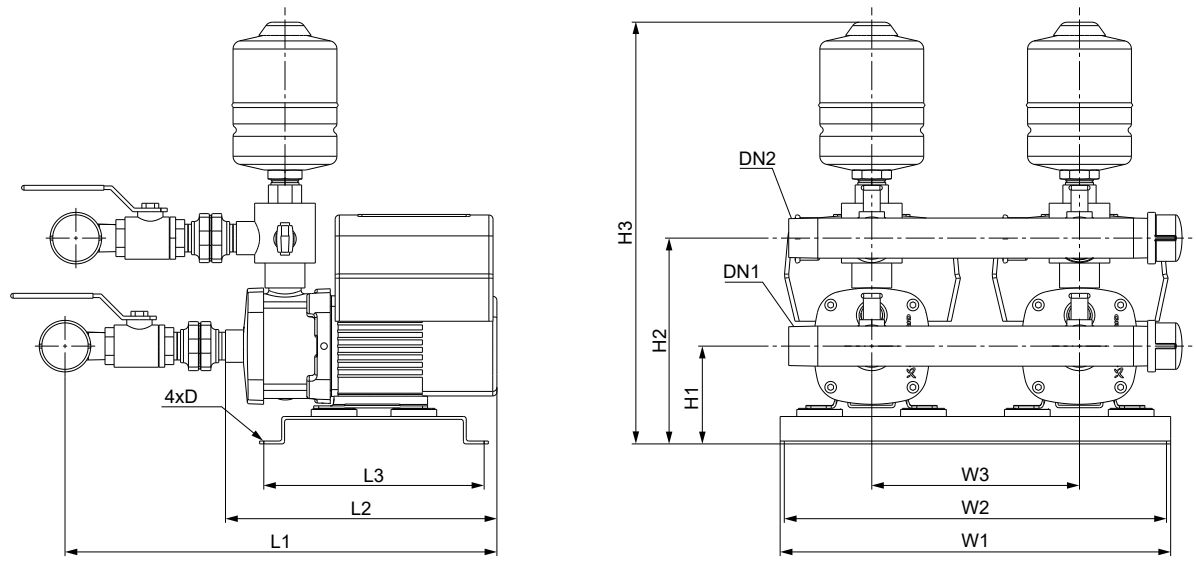

TM090712

### Dimensions of CMBE TWIN

	L1	L2	L3	W1	W2	W3	H1	H2	H3	D	DN1	DN2	Weight
	[inch]	[inch]	[inch]	[inch]	[inch]	[inch]	[inch]	[inch]	[inch]	[inch]			[lb]
	[mm]	[mm]	[mm]	[mm]	[mm]	[mm]	[mm]	[mm]	[mm]	[mm]			[kg]
CMBE TWIN 1-44	20.4 (517)	13 (313)	9.8 (249)	19.6 (498)	18.5 (470)	9.9 (250)	4.3 (108)	9.3 (235)	19.6 (498)	0.49 (12.5)	1 1/2 NPT	1 1/2 NPT	120 (54.5)
CMBE TWIN 3-51	20.4 (517)	12.3 (313)	9.8 (249)	19.6 (498)	18.5 (470)	9.9 (250)	4.3 (108)	9.3 (235)	19.6 (498)	0.49 (12.5)	1 1/2 NPT	1 1/2 NPT	55.8 (123)
CMBE TWIN 10-54	26.8 (681)	16.3 (414)	9.8 (249)	21.1 (536)	20.5 (520)	11.8 (300)	4.6 (117)	11.0 (280)	22.0 (559)	0.49 (12.5)	2 NPT	2 NPT	81.7 (180)

Performance curve

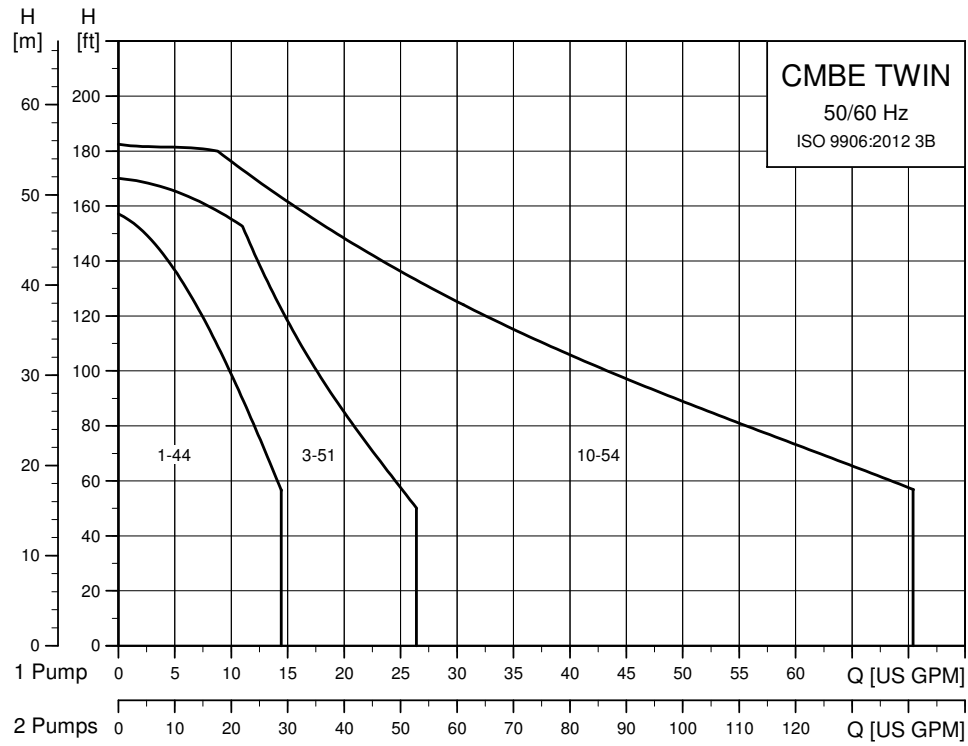

TM090949

## 4. Product numbers

All models have integrated variable frequency drive.

### CMBE TWIN, 1 × 220-240 V, 60 Hz

Pump type	Product number
CMBE TWIN 10-54	99503875

### CMBE TWIN, 1 × 115 V, 60 Hz

Pump type	Product number
CMBE TWIN 1-44	99503861
CMBE TWIN 3-51	99503873

### CMBE, 1 × 200-240 V, 60 Hz

Pump type	Product number
CMBE 1-44	98548109
CMBE 1-75	98548110
CMBE 1-99	98548111
CMBE 3-30	98548112
CMBE 3-62	98548113
CMBE 3-93	98548114
CMBE 5-31	98548115
CMBE 5-62	98548116
CMBE 10-54	98548118

### CMBE, 1 × 115 V, 60 Hz

Pump type	Product number
CMBE 1-44	98810910
CMBE 1-75	98810921
CMBE 3-30	98810922
CMBE 3-51	98810924

## 5. Grundfos Product Center

Online search and sizing tool to help you make the right choice.

From the international view, you can select your specific country to view the product range available to you.

International view: <http://product-selection.grundfos.com>

### All the information you need in one place

Performance curves, technical specifications, pictures, dimensional drawings, motor curves, wiring diagrams, spare parts, service kits, 3D drawings, documents, system parts. The Product Center displays any recent and saved items - including complete projects - right on the main page.

### Downloads

On the product pages, you can download installation and operating instructions, data booklets, service instructions, etc., in PDF format.

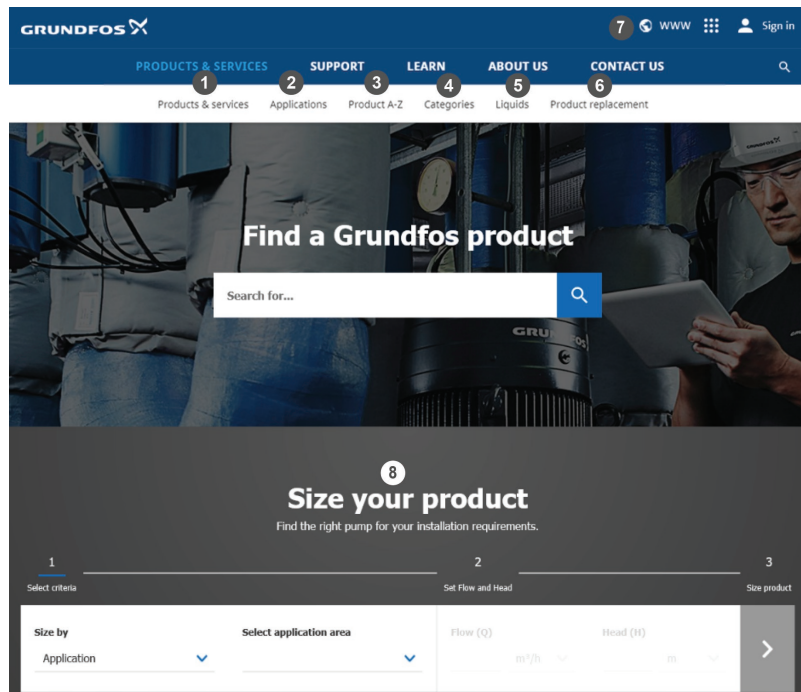
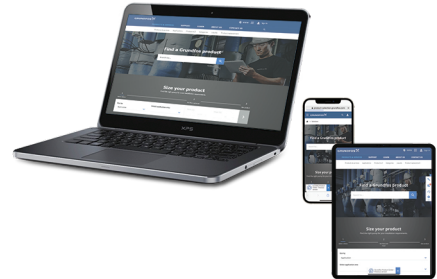

When you select your country, you will see the menus below. Note that some menus may not be available depending on the country.

Example: <https://product-selection.grundfos.com/uk>

Pos.	Description
1	<b>Products &amp; services</b> enables you to find products and documents by typing a product number or name into the search field.
2	<b>Applications</b> enables you to choose an application to see how Grundfos can help you design and optimize your system.
3	<b>Products A-Z</b> enables you to look through a list of all the Grundfos products.
4	<b>Categories</b> enables you to look for a product category.
5	<b>Liquids</b> enables you to find pumps designed for aggressive, flammable or other special liquids.
6	<b>Product replacement</b> enables you to find a suitable replacement.
7	<b>WWW</b> enables you to select the country, which changes the language, the available product range and the structure of the website.
8	<b>Sizing</b> enables you to size a product based on your application and operating conditions.

## 6. Document quality feedback

To provide feedback about this document, use your smart device to scan the QR code.



FEEDBACK\_98647967

[Click here to submit your feedback](#)

<b>98647967</b> 10.2025
ECM: 1427758

**GRUNDFOS Holding A/S**  
Poul Due Jensens Vej 7  
DK-8850 Bjerringbro  
Tel: +45 87 50 14 00  
[www.grundfos.com](http://www.grundfos.com)

