

MAGNA3

From Model D

Circulator pumps

50/60 Hz



1. Product description	3	12. Product numbers	68
Type key	4	Single-head pumps	68
Model type	4	Twin-head pumps	68
Pump heads in twin-head pumps	4		
Performance range, MAGNA3	5	13. Grundfos Product Center	69
Performance range, MAGNA3 D single-head operation	5	Grundfos GO	70
	6		
Performance range, MAGNA3 D twin-head operation	6		
2. Product range	7		
Pump selection	7		
3. System applications	9		
Heating systems	9		
Cooling systems	11		
Ground source heat pump systems (GSHP)	13		
Solar-heating systems	13		
4. Functions	14		
Control modes: Quick overview	15		
Operating modes	17		
Control modes	17		
Additional control mode features	22		
Multipump modes	24		
Flow estimation accuracy	24		
Readings on the pump	25		
5. Operating conditions	34		
General recommendations	34		
Closed valve operation	35		
Pumped liquids	35		
Electrical data	36		
6. Construction	37		
7. Installation	39		
Mechanical installation	39		
Electrical installation	39		
Connection to power supply, terminal-connected versions	40		
8. Operating the product	42		
Operating panel	42		
Grundfos GO Remote	42		
9. Curve conditions	43		
Performance curves	43		
QR code on the pump nameplate	43		
Markings and approvals	44		
10. Performance curves and technical data	45		
11. Accessories	63		
Insulating kits for applications with ice buildup	63		
CIM modules	63		
Grundfos GO Remote	64		
External Grundfos sensors	65		
Cable for sensors	66		
Blanking flange	66		
Pipe connections	67		

1. Product description



TM05 8894 2813

The Grundfos MAGNA3 model D circulator pumps are designed for circulating liquids in systems with variable flow requirements where you want to optimize the setting of the pump duty point, thus reducing energy costs.

Applications

- Heating systems
 - main pump
 - mixing loops
 - heating surfaces
- air-conditioning and cooling systems
- domestic hot-water systems
- ground source heat-pump systems
- solar-heating systems.

The MAGNA3 circulator pump is perfect for both new systems as well as for replacement. The pump is ideal when operating in systems requiring an automated adjustment of pressure. This pump range is the best choice as it eliminates the need for expensive bypass valves and similar components.

Furthermore, the pump is appropriate for systems with hot-water priority as an external signal can immediately force the pump to operate according to the maximum curve, for example in solar-heating systems. When using the pumps in domestic hot-water systems, please observe local legislation regarding pump house material. Grundfos strongly recommends that you use stainless-steel pumps in domestic hot-water applications to avoid corrosion.

Application wizard

MAGNA3 features a built-in application wizard, which is accessed via the pump's operating panel. By specifying your system step by step, the application wizard identifies the best suited control mode for your application.

See [Application wizard](#), page 42.

Duty range

Data	MAGNA3 (N) Single-head pumps	MAGNA3 D Twin-head pumps
Maximum flow rate	345 gpm (78.5 m ³ /h)	484 gpm (110 m ³ /h)
Maximum head	60 ft (18 m)	
Maximum system pressure	175 psi (1.2 MPa) (12 bar)	
Liquid temperature	14 to 230 °F (-10 to +110 °C)	

To ensure correct operation, it is important that the duty points in the system match the duty range of the pump.

Characteristic features

- AUTO_{ADAPT}.
- FLOW_{LIMIT}.
- FLOW_{ADAPT} - a combination of the AUTO_{ADAPT} control mode and FLOW_{LIMIT} function.
- Built-in Grundfos differential-pressure and temperature sensor.
- Proportional-pressure control.
- Constant-pressure control.
- Constant-temperature control.
- Constant-curve duty.
- Maximum or minimum curve duty.
- Automatic night setback.
- Self-explanatory user interface with TFT display and high quality silicone push-buttons.
- Heat energy monitor.
- Wireless multipump function.

The complete range is available for a maximum system pressure of 175 psi (12 bar, 1.2 MPa), PN 12.

Benefits

- Low energy consumption due to the AUTO_{ADAPT} function, allowing the pump to adjust automatically to external factors, such as outside temperatures and consumption patterns.
- Simple installation.
- No maintenance and long life.
- Operating log history.
- Easy and simple system optimization.
- External control and monitoring enabled via add-on modules.
- No external motor protection required.
- Insulating shells for heating systems supplied with single-head pumps.
- Wide temperature range due to thermal separation of the control box and pump media.

Type key

Code	Example	MAGNA3	(D)	80	-120	(F)	(N)	360
	Type range MAGNA3							
D	Single-head pump Twin-head pump							
	Nominal diameter (DN) of inlet and outlet ports [mm]							
	Maximum head [dm]							
F	Pipe connection Flange							
	Pump housing material Cast iron Stainless steel							
	Port-to-port length [mm]							

Model type

This data booklet covers MAGNA3 from model D. The model version is stated on the nameplate. See fig. 1.



Fig. 1 Model type on pump nameplate

TM06 7734 4017

Pump heads in twin-head pumps

The twin-head pump housing has a flap valve on the outlet side. The flap valve seals off the port of the idle pump housing to prevent the pumped liquid from running back to the inlet side. See fig. 2. Due to the flap valve, there is a difference in the hydraulics between the two heads. See fig. 3.



Fig. 2 Twin-head pump housing with flap valve

TM06 1565 2514

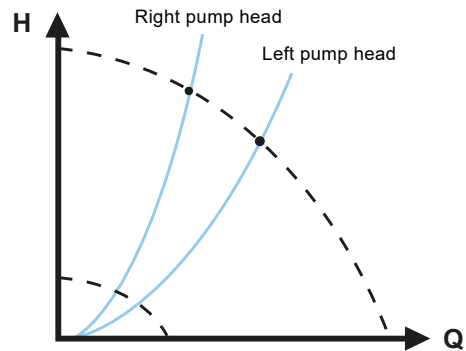

Fig. 3 Hydraulic difference between the two heads

TM06 1566 2514

Performance range, MAGNA3

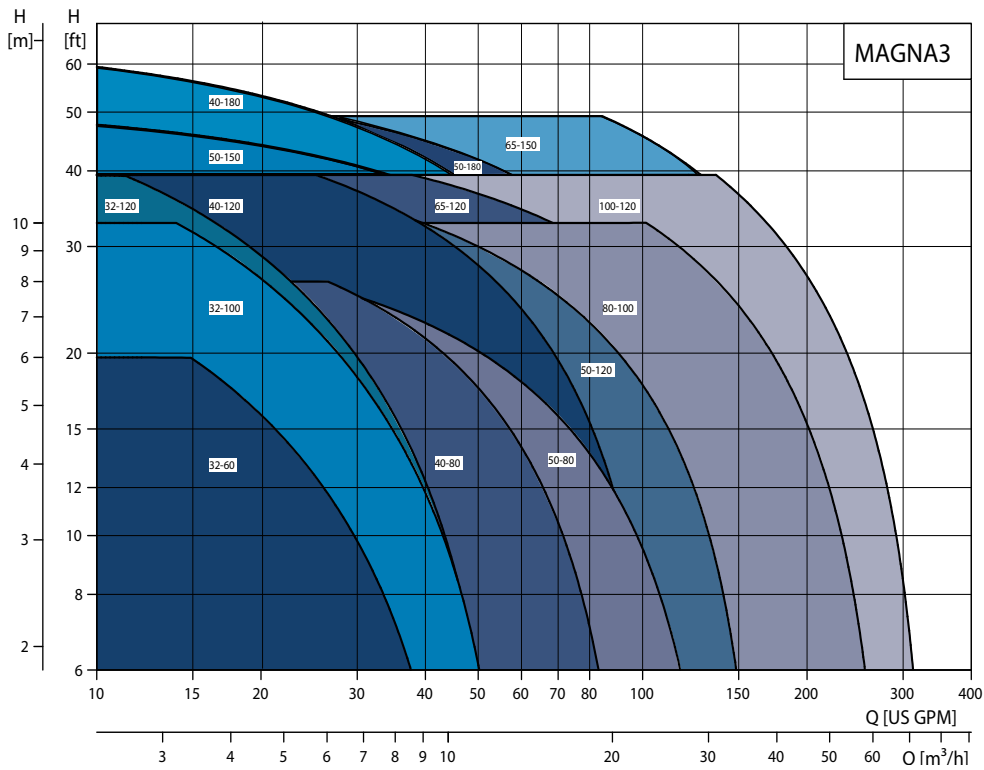

Fig. 4 Performance range, MAGNA3

TM05 7654 2818

Performance range, MAGNA3 D single-head operation

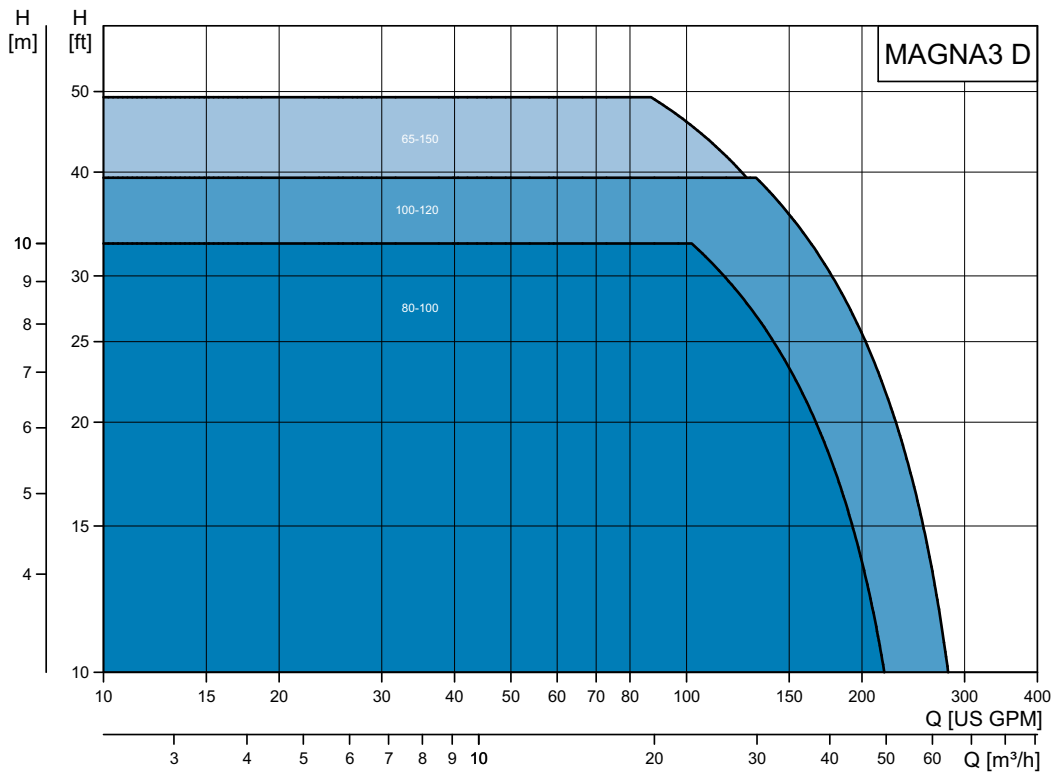

Fig. 5 Performance range, MAGNA3 D single-head operation

TM05 7655 2818

Performance range, MAGNA3 D twin-head operation

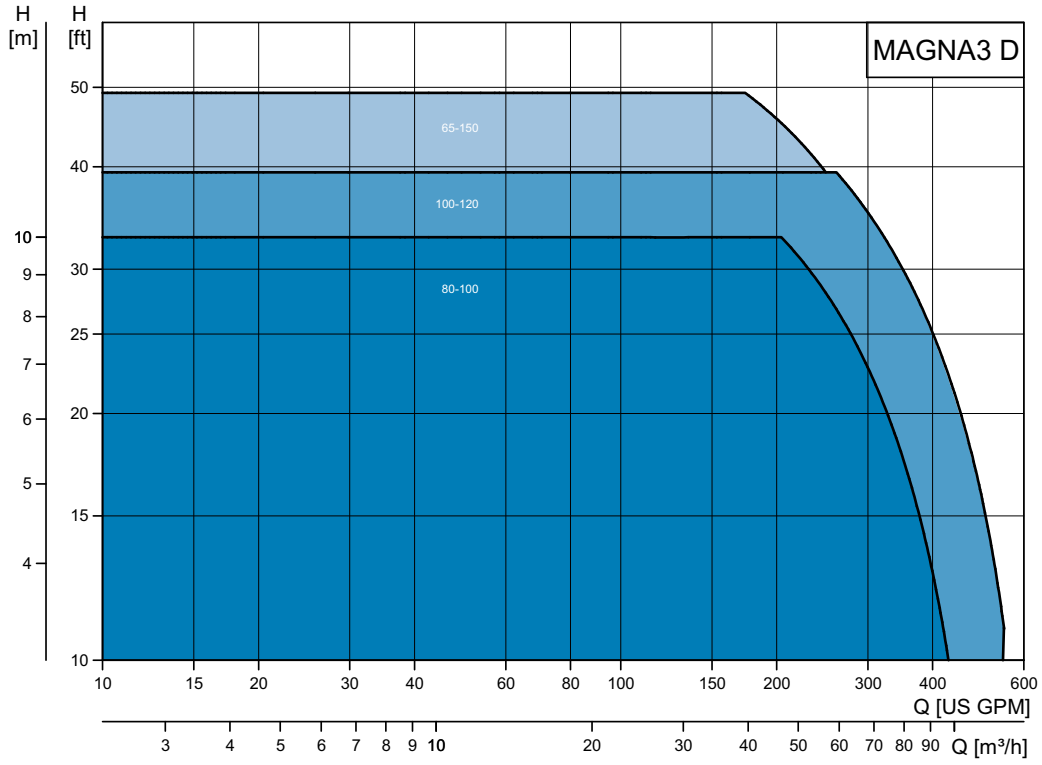

Fig. 6 Performance range, MAGNA3 D twin-head operation

TM05 7656 2818

2. Product range

	Port-to-port length [in. (mm)]	Cast iron		Stainless steel (N)		Page reference
		115 V	230 V	115 V	230 V	
Single-head pump models						
MAGNA3 32-60 F (N)	6 - 1/2 (165)	•	•	•	•	46
MAGNA3 32-100 F (N)	6 - 1/2 (165)	•	•	•	•	47
MAGNA3 32-120 F (N)	6 - 1/2 (165)	•	•	•	•	48
MAGNA3 40-80 F (N)	8 - 9/16 (216)	•	•	•	•	49
MAGNA3 40-120 F (N)	8 - 9/16 (216)	•	•	•	•	50
MAGNA3 40-180 F (N)	8 - 9/16 (216)	•	•	•	•	51
MAGNA3 50-80 F (N)	9 - 1/2 (240)	•	•	•	•	52
MAGNA3 50-120 F (N)	11 - 1/16 (280)	•	•	•	•	53
MAGNA3 50-150 F (N)	11 - 1/16 (280)	•	•	•	•	54
MAGNA3 50-180 F (N)	11 - 1/16 (280)	•	•	•	•	55
MAGNA3 65-120 F (N)	13 - 7/16 (340)	•	•	•	•	56
MAGNA3 65-150 F (N)	13 - 7/16 (340)		•		•	57
MAGNA3 80-100 F (N)	14 - 3/16 (360)		•		•	59
MAGNA3 100-120 F (N)	17 - 3/4 (450)		•		•	61
Twin-head pump models						
MAGNA3 D 65-150 F			•			58
MAGNA3 D 80-100 F			•			60
MAGNA3 D 100-120 F			•			62

Pump selection

All pumps have a "best point" (η_{\max}), indicating where the pump is working most efficiently.

Consider the parameters in the following section.

Pump size

The system characteristic is used together with the performance curve of the pump for sizing and correct pump selection.

The selection of pump size must be based on the following:

- required maximum flow
- maximum pressure loss in the system.

Refer to the system characteristics to determine the duty point. See fig. 7.

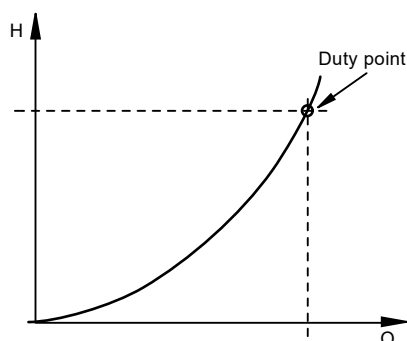

Fig. 7 System characteristic

TM02 2040 3301

Operating conditions

You must check whether the operating conditions are fulfilled, i.e.:

- liquid quality and temperature
- ambient conditions
- minimum inlet pressure
- maximum operating pressure.

See also [Operating conditions](#), page 34.

Control modes

- $AUTO_{ADAPT}$ (factory setting) which is suitable for most installations.
- $FLOW_{ADAPT}$ in systems where flow limitation is required.
- Proportional-pressure control in systems with considerable pressure losses in relation to large flow variations.
- Constant-pressure control in systems with insignificant pressure losses in relation to large flow variations.
- Constant-temperature control in systems with a fixed system characteristic, for example domestic hot-water systems.
- Differential-temperature control in heating and cooling systems.
- Constant flow in systems where a constant flow is required independently of the head.
- Constant-curve duty.

For further information on control and operating modes, see [Functions](#), page 14.

Automatic determination of the setpoint

If you know the duty point, you can enter the value on the display when setting the pump. The pump then automatically calculates the corresponding setpoint. See fig. 8.

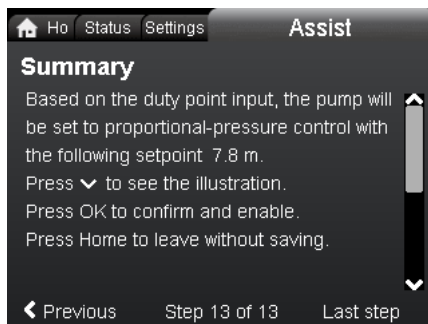

4.1.1.0.0.0 - 13A

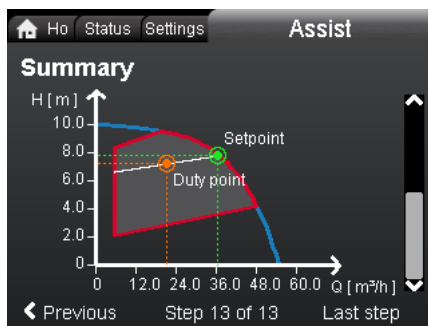

4.1.1.0.0.0 - 13B

Fig. 8 Example of setpoint calculation based on a chosen control mode and entered Q and H values

Communication

The Grundfos CIM modules (Communication Interface Module) enable the MAGNA3 to connect to standard fieldbus networks, offering substantial benefits:

- complete process control and monitoring
- modular design, prepared for future requirements
- based on standard functional profiles
- simple configuration and easy installation
- open communication standards
- reading warning and alarm indications.

For further details, see [CIM modules](#), page 27.

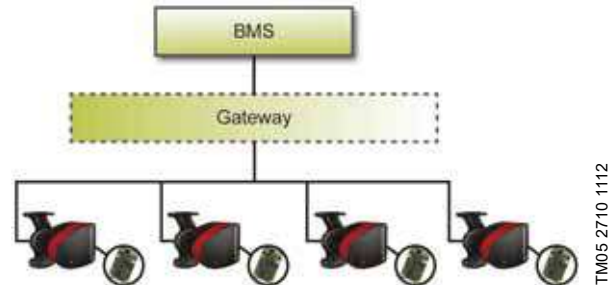

TM05 2710 1112

Fig. 9 Example of a typical building management system (BMS)

Note: A gateway is a device that facilitates the transfer of data between two different networks based on different communication protocols.

3. System applications

Heating systems

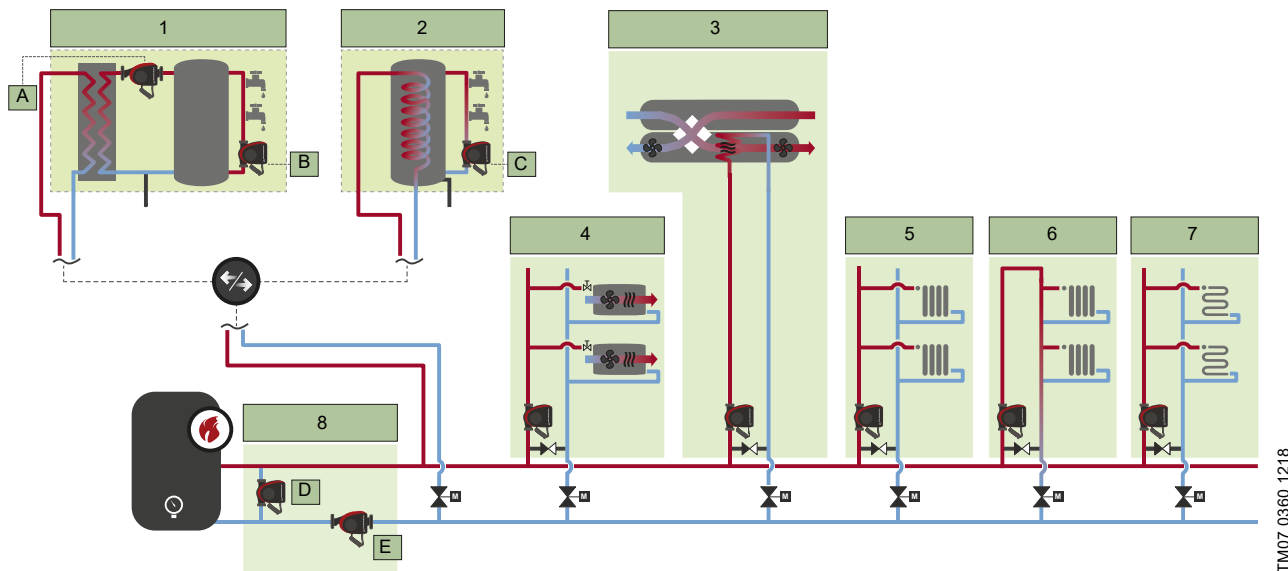

Fig. 10 Functional drawing of a heating system in a commercial building

Pos.	Description
1	Hot water
1A	Charging pump
1B	Recirculation
2	Hot water
2A	Recirculation
3	Air handling unit
4	Fan coil unit
5	Radiator two-pipe system
6	Radiator one-pipe system
7	Underfloor/ceiling
8	Boiler pump
8D	Shunt/buffer
8E	'Primary only' system

The following sections provide recommendations on which control mode to choose according to your application and where the pump is placed in the system.

In addition, you can use MAGNA3's built-in application wizard to help you identify which control mode is best suited your application. See [Application wizard](#), page 42.

1A. Hot water, charging pump

Hot-water applications often have an external controller, which starts the pump when the temperature falls below a desired setpoint. The pump will run until the temperature in the tank is back up.

If the design flow is known, it can be set directly on the pump. The suitable control mode is constant flow.

If only the desired differential temperature across the plate heat exchanger is known, constant speed curves can be chosen and adjusted to reach the desired delta T.

See [Constant flow](#), page 21, and [Constant curve](#), page 21.

1B. Hot water, recirculation

The constant-temperature control mode together with the pump's internal temperature sensor makes it possible to maintain any given temperature of the return water. The desired temperature setpoint is set directly on the pump.

If you want to maintain a certain temperature at a critical point furthest out in the system, the constant-temperature control mode can be used in combination with an external temperature sensor.

See [Constant temperature](#), page 20.

2A. Hot water, recirculation

See [1B. Hot water, recirculation](#).

3. Air handling unit

Constant flow

If the air flow temperature and thereby the heat output is controlled by for example a motorised valve, the system is typically operating with constant flow. Therefore, we recommend that the pump operates in the constant-flow control mode.

See [Constant curve](#), page 21.

Variable flow

Normally, the distance between the pump and the air handling unit is short, eliminating pressure losses almost completely even if the flow varies. Therefore, the constant-pressure control mode is suitable in this type of application.

See [Constant pressure](#), page 19.

4. Fan coil unit

Typically, fan coil units are situated at a considerable distance from the pump.

Therefore, depending on how many fan coils are operating and at which demand, large variations in pressure loss will occur.

In such applications proportional pressure is the recommended control mode.

If the pressure losses are unknown, you can choose the $AUTO_{ADAPT}$ control mode, which will automatically adjust the pump performance to the actual system characteristic.

See [Proportional pressure](#), page 19, and [AUTO_{ADAPT}](#), page 17.

5. Radiator, two pipe

Since these applications have varying pressure losses due to the distance between the pump and radiators, we recommend that the pump operates in the proportional-pressure control mode.

If the pressure losses are unknown, it is possible to use the $AUTO_{ADAPT}$ control mode, which will automatically adjust the pump performance to the actual system characteristic.

See [Proportional pressure](#), page 19, and [AUTO_{ADAPT}](#), page 17.

6. Radiator, one pipe

In one-pipe radiator systems the flow is typically constant, making the pressure losses constant as well. Therefore, pumps in these applications are best suited to operate in constant-pressure control mode.

Because these applications are often designed with a specific differential temperature, it is possible to adjust the constant-pressure setpoint until this differential temperature is achieved.

See [Constant pressure](#), page 19.

7. Underfloor/ceiling

In these systems the flow will vary depending on how many rooms are in operation. However, since the distance is short between the pump and manifold, to which the pipes are connected, there is no variation in pressure losses. Because of this the constant-pressure control mode is the optimum choice. See [Constant pressure](#), page 19.

8D. Shunt/buffer

Constant temperature with internal sensor

If both the return temperature and the desired minimum temperature back to the boiler are known, you can calculate the required flow temperature supplied by the shunt pump.

The calculated flow temperature is set directly on the pump, when setting the control mode to constant temperature.

See [Constant temperature](#), page 20.

Constant temperature with external sensor

The minimum required return temperature back to the boiler can be measured and controlled by the use of an external temperature sensor placed close to the boiler. This temperature can then be set directly on the pump together with the constant-temperature control mode.

See [Constant temperature](#), page 20.

Constant differential temperature

If the purpose of the boiler shunt pump is to secure that a maximum differential temperature across a boiler is not exceeded, choose the differential temperature control mode. Despite load variations, the differential temperature is then kept on a desired level. This requires an additional temperature sensor.

8E. 'Primary only' system

These pumps are characterised by operating with large variations in flow. Depending on the distance between the pump and the last branch served by the pump, either constant-pressure or proportional-pressure control modes can be chosen.

Typically, proportional pressure will be the better option if the pressure is above 5 m or the distance between the pump and the last branch exceeds 10 m.

On the other hand, if pressure loss variations are limited because all branches are connected closer to the pump, constant pressure will be the recommended control mode.

See [Proportional pressure](#), page 19, and [Constant pressure](#), page 19.

Cooling systems

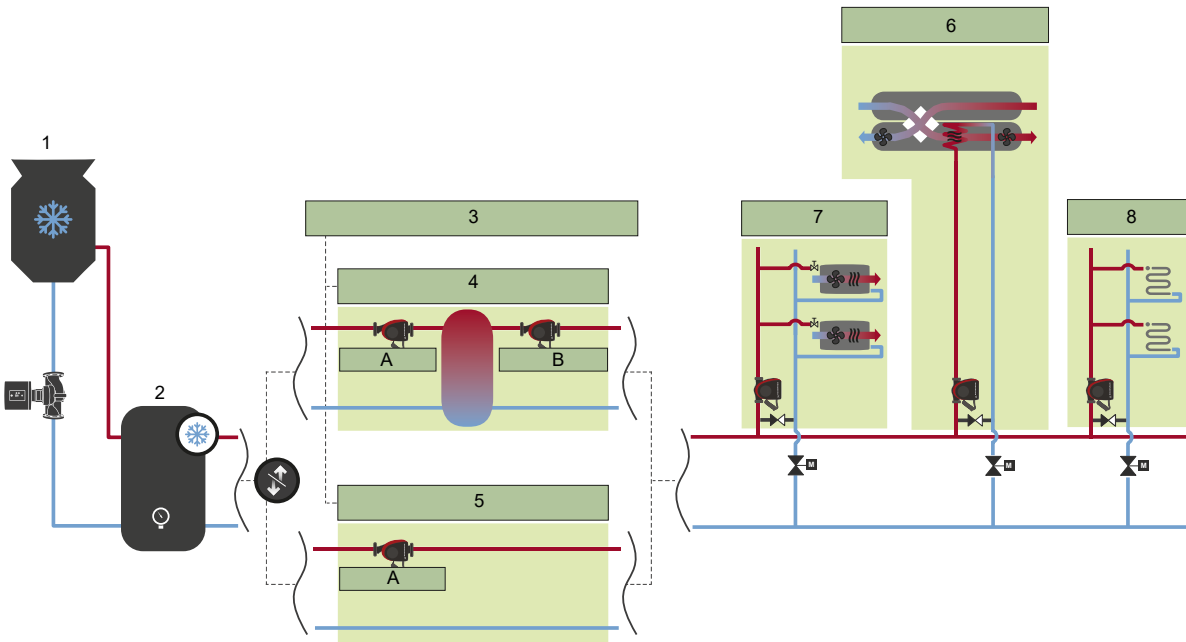

TM07 0358 1218

Fig. 11 Functional drawing of a cooling system in a commercial building

Pos.	Description
1	Cooling tower
2	Cooling source
3	Chiller pump
4	Primary/secondary system
4A	Primary pump
4B	Secondary pump
5	"Primary only" system
5A	Primary pump
6	Air handling unit
7	Fan coil unit
8	Underfloor/ceiling

The following sections provide recommendations on which control mode to choose according to your application and where the pump is placed in the system.

In addition, you can use MAGNA3's built-in application wizard to help you identify which control mode is best suited your application. See [Application wizard](#), page 42.

4A. Primary/secondary system, primary pump

Constant temperature

If the setpoint temperature from the chiller is known and the aim is to maintain this temperature all the way to the buffer tank, the constant-temperature control mode can be chosen.

Depending on the position of the pump, the internal or an external temperature sensor can be used to measure the temperature.

See [Constant temperature](#), page 20.

Differential temperature

If the design differential temperature across the chiller is known, the differential temperature control mode can be selected. This requires an additional temperature sensor.

See [Differential temperature](#), page 20.

Constant flow

In cases where the chiller is not varying, the pump is typically started and stopped by the chiller. This indicates a requirement for constant flow, hence this being the optimum control mode.

See [Constant curve](#), page 21.

Constant curve

In cases where the chiller is not varying and the required delta-T is known, the constant-curve control mode can be used. Here, the constant curve is adjusted until the desired delta-T is obtained.

See [Constant curve](#), page 21.

4B. Primary/secondary system, secondary pump

Secondary pumps are exposed to large variations in flow and pressure losses due to load variations in the system. For this reason, proportional pressure is the recommended control mode.

If the pressure losses are below 5 mWc, the constant pressure control mode is a good alternative.

If the pressure losses are unknown, you can choose the AUTO_{ADAPT} control mode, which will automatically adjust the pump performance to the actual system characteristic.

See [Proportional pressure](#), page 19, [Constant pressure](#), page 19, and [AUTO_{ADAPT}](#), page 17.

5A. 'Primary only' system, primary pump

These pumps are exposed to large variations in flow and pressure losses due to load variations in the system. For this reason, proportional pressure is the recommended control mode.

If the pressure losses are below 5 mWc, the constant-pressure control mode is a good alternative.

If the pressure losses are unknown, you can choose the AUTO_{ADAPT} control mode, which will automatically adjust the pump performance to the actual system characteristic.

See [Proportional pressure](#), page 19, [Constant pressure](#), page 19, and [AUTO_{ADAPT}](#), page 17.

6. Air handling unit

If the required flow in the coil is known, constant flow is the preferred control mode. Here, the pump will adjust to the needed pressure.

The actual heat supply is controlled by the motorised valves as shown in fig. 11.

If the pressure loss in the coil is known, constant pressure is a suitable control mode. This control mode ensures that the pump is able to overcome the pressure loss.

See [Constant curve](#), page 21 and [Constant pressure](#), page 19.

7. Fan coil unit

Fan coil applications are characterised by variable flow due to a varying number of coils in operation. The more coils in operation the higher the pressure loss.

Therefore, proportional pressure is the optimum control mode.

See [Proportional pressure](#), page 19.

8. Underfloor/ceiling

In an underfloor/ceiling application the circuits are individually balanced according to pressure loss. This means that all circuits have the same pressure loss even though they may differ in length.

Even if the flow varies, the pressure loss will remain the same, and for this reason constant pressure is the recommended control mode.

See [Constant pressure](#), page 19.

Ground source heat pump systems (GSHP)

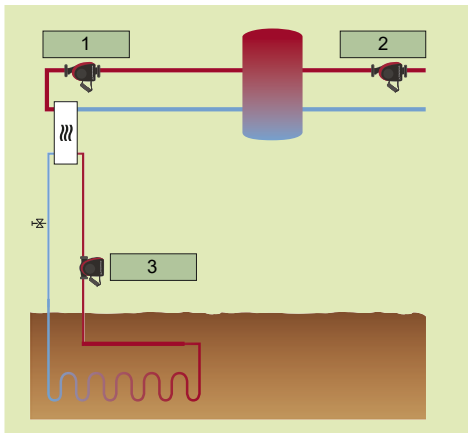

TM07 0359 1218

Fig. 12 Ground source heat pump system in a commercial building

Pos.	Description
1	Charging pump
2	Distribution side
3	Ground loop

The following sections provide recommendations on which control mode to choose according to your application and where the pump is placed in the system.

In addition, you can use MAGNA3's built-in application wizard to help you identify which control mode is best suited your application. See [Application wizard](#), page 42.

1. Charging pump

If the temperature in the tank falls below a certain threshold, the charging pump starts. The pump operates until the tank temperature is back up at the desired level.

As this is a closed circuit with no flow variations, constant-flow or constant-curve operation are suitable control modes.

See [Constant flow](#), page 21 and [Constant curve](#), page 21.

2. Distribution side

If the distribution pump is connected to a radiator system, proportional pressure is the optimum control mode. If underfloor heating is connected right after the pump, constant pressure is preferred.

See [Proportional pressure](#), page 19, and [Constant pressure](#), page 19.

3. Ground loop

Since the ground loop is a closed system with no variations in flow, the most suitable control modes are constant flow and constant curve.

See [Constant flow](#), page 21 and [Constant curve](#), page 21.

Solar-heating systems

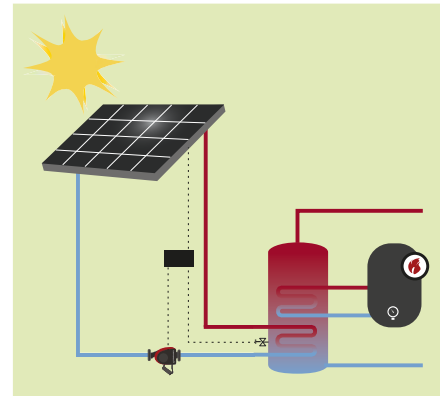

TM07 0367 1218

Fig. 13 Functional drawing of a solar-heating system

We recommend that the main pump in a solar-heating system operates with the constant-curve control mode or as recommended by the solar system provider.

Alternative control modes, like constant temperature or differential temperature, can be viable options, but the must only be chosen based on dialogue with the solar system provider.

See [Constant curve](#), page 21, [Constant temperature](#), page 20, and [Differential temperature](#), page 20.

4. Functions

	Page
Operating modes	17
Normal (control modes enabled)	17
Stop	17
Minimum curve	17
Maximum curve	17
Control modes	17
AUTO _{ADAPT} (factory setting)	17
FLOW _{ADAPT}	18
Proportional pressure	19
Constant pressure	19
Constant temperature	20
Differential temperature	20
Constant flow	21
Constant curve	21
Additional control mode features	22
FLOW _{LIMIT}	22
Automatic Night Setback	23
Multipump modes	24
Alternating operation	24
Backup operation	24
Cascade operation	24
Readings and settings on the pump	25
Operating panel and display	25
Operating status	25
Pump performance	25
Warning and alarm	25
Heat energy monitor	25
Operating log	26
Grundfos Eye (status indicator)	26
Communication	26
Wireless Grundfos GO	26
Wireless GENlair connection	27
Pump information to BMS via CIM modules	27
Bus via GENibus	28
Bus via LonWorks	28
Bus via PROFIBUS DP	28
Bus via Modbus RTU	28
Bus via BACnet MS/TP	28
Digital inputs	30
Relay outputs	31
Analog input for external sensor	31
External setpoint function	33

Control modes: Quick overview

AUTO_{ADAPT}

- We recommend this control mode for most heating systems.
- During operation, the pump automatically makes the necessary adjustment to the actual system characteristic.

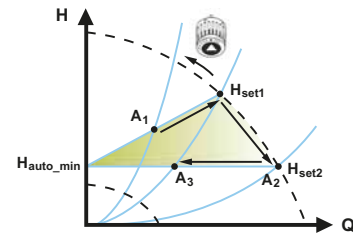

FLOW_{ADAPT}

The FLOW_{ADAPT} control mode combines a control mode and a function:

- The pump is running in AUTO_{ADAPT}.
- The delivered flow from the pump will never exceed a selected FLOW_{LIMIT}.

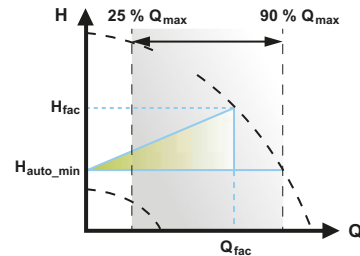

Proportional pressure

- Used in systems with relatively large pressure losses in the distribution pipes.
- The head of the pump will increase proportionally to the flow in the system to compensate for the large pressure losses in the distribution pipes.

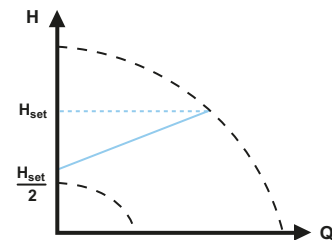

Constant pressure

- We recommend this control mode in systems with relatively small pressure losses.
- The pump head is kept constant, independent of the flow in the system.

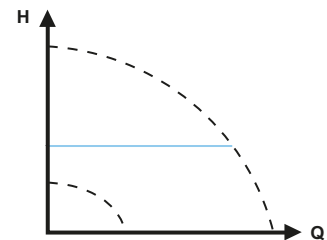

Constant temperature

In systems with a fixed system characteristic, for example domestic hot-water systems, the control of the pump according to a constant return-pipe temperature is relevant.

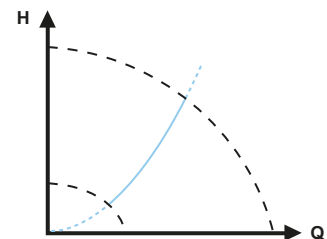

Differential temperature

- Ensures a constant differential temperature drop across heating and cooling systems.
- The pump will maintain a constant differential temperature between the pump and the external sensor.

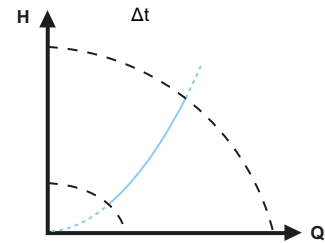

Constant flow

Note: Available for pumps with production code from 1838.

- The pump maintains a constant flow in the system independently of the head.
- It is not possible to use an external sensor, instead, the pump uses its internal sensor.

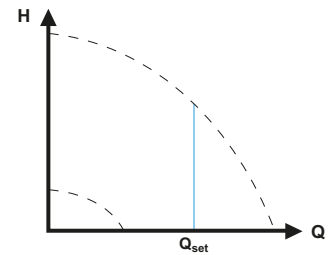

Constant curve

- The pump can be set to operate according to a constant curve, like an uncontrolled pump.
- Set the desired speed in % of the maximum speed in the range from minimum to 100 %.

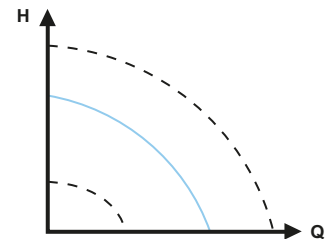

For multipump modes, see [Multipump modes](#), page 24.

Operating modes

Normal

The pump runs according to the selected control mode.

Note: You can select the control mode and setpoint even if the pump is not running in Normal mode.

Stop

The pump stops.

Min.

You can use the minimum curve mode in periods where a minimum flow rate is required.

This operating mode is for instance suitable for manual night setback if automatic night setback is not desired.

The minimum curve can be adjusted by defining the pump's operating range.

Max.

You can use the maximum curve mode in periods where a maximum flow rate is required.

This operating mode is for instance suitable for hot-water priority.

You can select the normal, stop, min. and max. operating modes directly by use of the built-in digital inputs. See [Connection to power supply, terminal-connected versions](#), page 40.

The maximum curve can be adjusted by defining the pump's operating range.

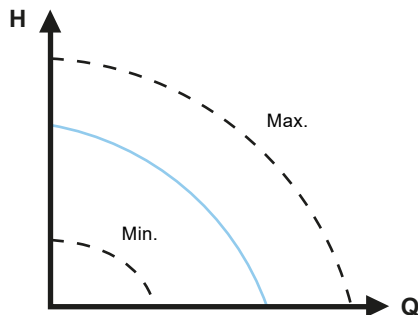

Fig. 14 Maximum and minimum curves

Control modes

Factory setting

The pumps have been factory-set to $AUTO_{ADAPT}$ without automatic night setback, which is suitable for most installations.

The setpoint has been factory-set. See [Readings on the pump](#), page 25.

$AUTO_{ADAPT}$

We recommend the $AUTO_{ADAPT}$ control mode for most heating systems, especially in systems with relatively large pressure losses in the distribution pipes, and in replacement situations where the proportional-pressure duty point is unknown.

This control mode has been developed specifically for heating systems and we do not recommend it for air-conditioning and cooling systems.

Characteristics and key benefits

- Automatically adjusts the pump to actual system characteristics.
- Ensures minimum energy consumption and a low noise level.
- Reduced operating costs and increased comfort .

Technical specifications

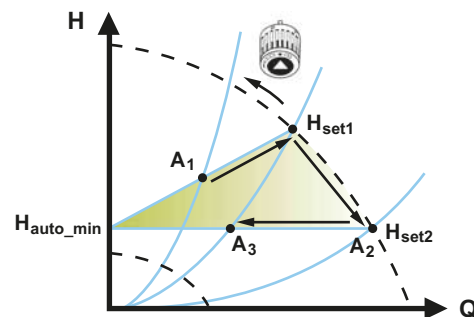

Fig. 15 $AUTO_{ADAPT}$ control

- A_1 : Original duty point
- A_2 : Lower registered head on the max. curve
- A_3 : New duty point after $AUTO_{ADAPT}$ control
- H_{set1} : Original setpoint
- H_{set2} : New setpoint after $AUTO_{ADAPT}$ control
- H_{fac} : See page 25
- H_{auto_min} : A fixed value of 1.5 m

The $AUTO_{ADAPT}$ control mode is a form of proportional-pressure control where the control curves have a fixed origin, H_{auto_min} .

When you have enabled $AUTO_{ADAPT}$, the pump will start with the factory setting, $H_{fac} = H_{set1}$, corresponding to approximately 55 % of its maximum head, and then adjust its performance to A_1 . See fig. 15.

When the pump registers a lower head on the maximum curve, A_2 , the $AUTO_{ADAPT}$ function automatically selects a correspondingly lower control curve, H_{set2} . If the valves in the system close, the pump adjusts its performance to A_3 . See fig. 15.

Note: Manual setting of the setpoint is not possible.

TM05 2446 5111

TM05 2452 1312

FLOW_{ADAPT}

The FLOW_{ADAPT} control mode combines AUTO_{ADAPT} and FLOW_{LIMIT}, meaning that the pump runs AUTO_{ADAPT} while at the same time ensuring that the flow rate never exceeds the entered FLOW_{LIMIT} value. This control mode is suitable for systems where a maximum flow limit is desired and where a steady flow through the boiler in a boiler system is required. Here, no extra energy is used for pumping too much liquid into the system.

In systems with mixing loops, you can use FLOW_{ADAPT} to control the flow in each loop.

Characteristics and key benefits

- The dimensioned flow for each zone (required heat energy) is determined by the flow from the pump. This flow rate can be set precisely in the FLOW_{ADAPT} control mode without using throttling valves.
- When the flow rate is set lower than the balancing valve setting, the pump will ramp down instead of losing energy by pumping against a balancing valve.
- Cooling surfaces in air-conditioning systems can operate at high pressure and low flow rate.

Note: The pump cannot reduce the flow rate on the inlet side, but is able to control that the flow rate on the outlet side is at least the same as on the inlet side, as the pump has no built-in valve.

Technical specifications

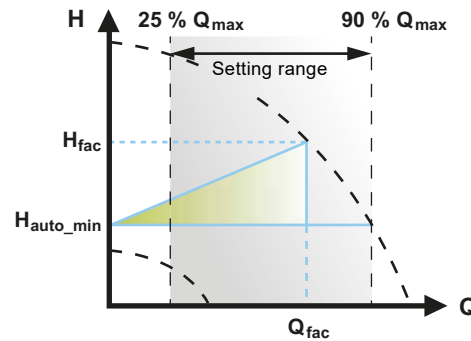

Fig. 16 FLOW_{ADAPT} control

The factory setting of the FLOW_{ADAPT} is the flow rate where the AUTO_{ADAPT} factory setting meets the maximum curve. See fig. 16.

The typical pump selection is based on the required flow rate and calculated pressure losses. The pump is typically oversized by 30 to 40 % to ensure that it can overcome the pressure losses in the system. Under these conditions, the full benefit of AUTO_{ADAPT} cannot be obtained.

To adjust the maximum flow rate of this "oversized" pump, balancing valves are built into the circuit to increase the resistance and thus reduce the flow rate.

The FLOW_{ADAPT} function reduces the need for a pump throttling valve, see fig. 17, but does not eliminate the need for balancing valves in heating systems.

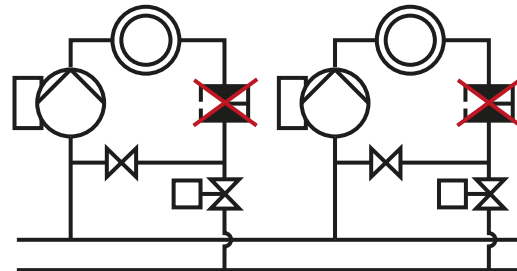

Fig. 17 Reduced need for a pump throttling valve

TM05 3334 1312

TM05 2685 1212

Proportional pressure

Proportional pressure is suitable in systems with relatively large pressure losses in the distribution pipes and in air-conditioning and cooling systems:

- Two-pipe heating systems with thermostatic valves and the following:
 - very long distribution pipes
 - strongly throttled pipe balancing valves
 - differential-pressure regulators
 - large pressure losses in the parts of the system through which the entire amount of water flows, for example a boiler, heat exchanger and distribution pipe up to the first branching.
- Primary circuit pumps in systems with large pressure losses in the primary circuit.
- Air-conditioning systems with the following:
 - heat exchangers (fan coils)
 - cooling ceilings
 - cooling surfaces.

Characteristics and key benefits

- The head of the pump increases proportionally to the flow rate in the system.
- Compensates for large pressure losses in the distribution pipes.

Technical specifications

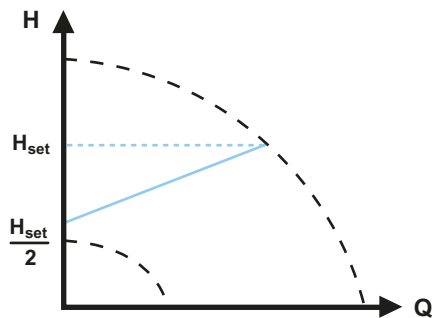

Fig. 18 Proportional-pressure control

The head against a closed valve is half the setpoint H_{set} .

TM05 2448 1212

Constant pressure

A constant pressure is advantageous in systems with relatively small pressure losses in the distribution pipes:

- Two-pipe heating systems with thermostatic valves:
 - dimensioned for natural circulation
 - small pressure losses in the parts of the system through which the entire amount of water flows, for example a boiler, heat exchanger and distribution pipe up to the first branching.
 - modified to a high differential temperature between the flow pipe and the return pipe (for example district heating).
- Underfloor heating systems with thermostatic valves.
- One-pipe heating systems with thermostatic valves or pipe balancing valves.
- Primary circuit pumps in systems with small pressure losses in the primary circuit.

Characteristics and key benefits

- The pump pressure is kept constant, independent of the flow in the system.

Technical specifications

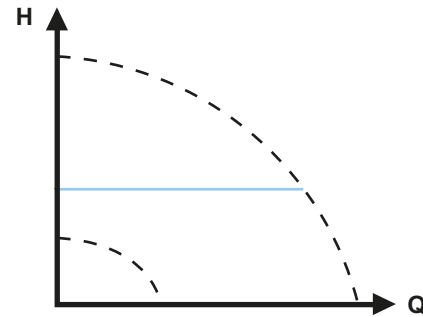

Fig. 19 Constant-pressure control

TM05 2449 0312

Constant temperature

This control mode is suitable in systems with a fixed system characteristic, for example domestic hot-water systems, where the control of the pump according to a constant return-pipe temperature is relevant.

The pump is from factory set to operate in a heating system with a controller gain, K_p , equal to 1. If the pump operates in a cooling system, the gain must be changed to a negative value, for example -1. This is done via the operating panel of the pump.

Characteristics and key benefits

- The temperature is kept constant.
- $FLOW_{LIMIT}$ is used to control the maximum circulation flow rate.

Technical specifications

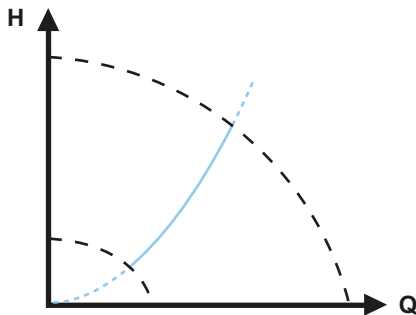

Fig. 20 Constant-temperature control

The inverse control for cooling application is available from model B.

Temperature sensor

If the pump is installed in the flow pipe, install an external temperature sensor in the return pipe of the system. See fig. 21. Install the sensor as close as possible to the consumer (radiator, heat exchanger, etc.).

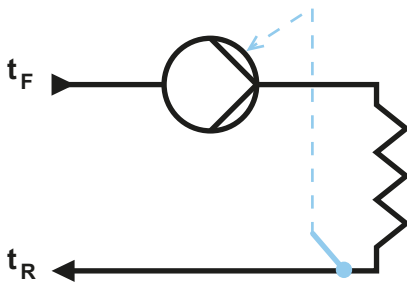

Fig. 21 Pump with an external sensor

If the pump is installed in the return pipe of the system, you can use the internal temperature sensor. In this case, install the pump as close as possible to the consumer (radiator, heat exchanger, etc.).

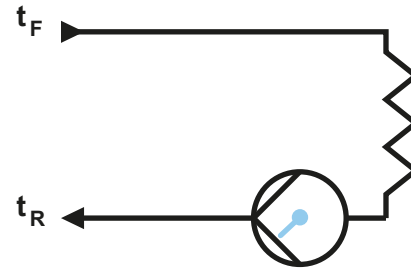

Fig. 22 Pump with an internal sensor

Differential temperature

Select this control mode if the pump performance is to be controlled according to a differential temperature in the system where the pump is installed.

Characteristics and key benefits

- Ensures a constant differential temperature drop across heating and cooling systems.
- Ensures a constant differential temperature between the pump and the external sensor, see figs 23 and 24.
- Requires two temperature sensors, the internal temperature sensor together with an external sensor.

Technical specifications

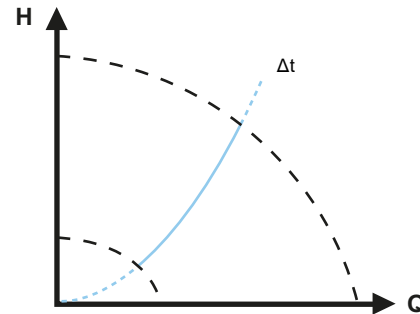

Fig. 23 Differential temperature

Temperature sensor

To measure the temperature difference of the flow pipe and the return pipe, you must use both the internal sensor and an external sensor. If the pump is installed in the flow pipe, the external sensor must be installed in the return pipe and vice versa. Always install the sensor as close as possible to the consumer (radiator, heat exchanger, etc.). See fig. 24.

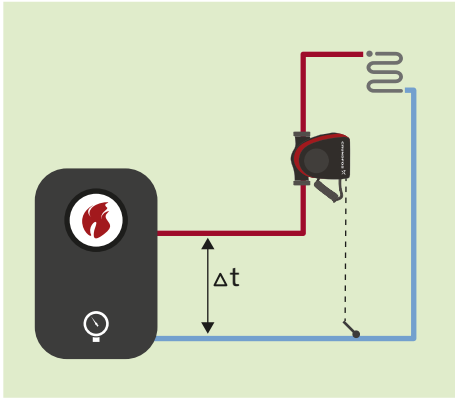

Fig. 24 Differential temperature

TM05 8236 2113

Constant flow

Note: Available for pumps with production code from 1838.

The pump maintains a constant flow in the system independently of the head. See fig. 25.

Constant flow is suitable in applications such as air handling units, hot-water systems and ground-source heating systems.

Characteristics and key benefits

- It is not possible to use an external sensor, instead, the pump uses its internal sensor.
- In multipump systems constant flow is only available in alternating and backup operation, not cascade operation.

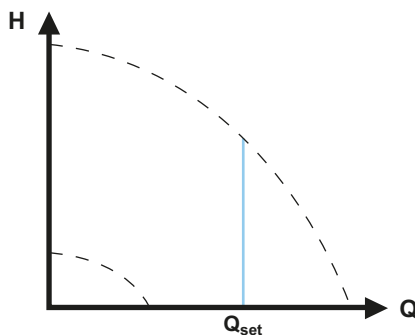

Fig. 25 Constant flow rate

TM05 7955 1713

Constant curve

A constant curve is suitable for systems, where both a constant flow rate and a constant head are required, i.e.:

- Heat surfaces
- cooling surfaces
- heating systems with 3-way valves
- air condition system with 3-way-valve
- chiller pumps

Characteristics and key benefits

- If an external controller is installed, the pump is able to change from one constant curve to another, depending on the value of the external signal.
- Depending on your preferences, the pump can be controlled according to either a maximum or minimum curve.

Technical specifications

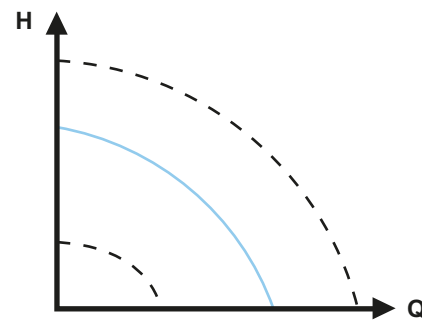

Fig. 26 Constant-curve duty

The pump can be set to operate according to a constant curve, like an uncontrolled pump. See fig. 26.

TM05 2446 5111

Depending on the pump model, you can set the desired speed in % of the maximum speed. The span of control depends on the minimum speed, power and pressure limitation of the pump.

Note: If the pump speed is set in the range between minimum and maximum, the power and pressure are limited when the pump is running on the maximum curve. This means that the maximum performance can be achieved at a speed lower than 100 %. See fig. 27.

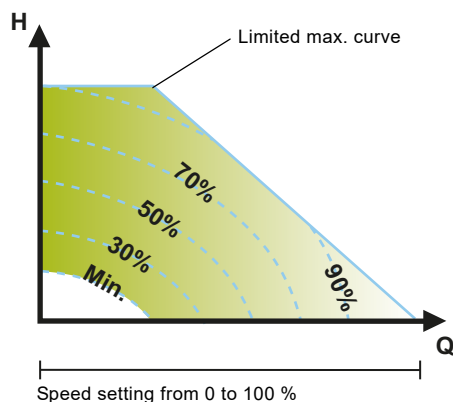

TM05 4266 2212

Fig. 27 Power and pressure limitations influencing the maximum curve

You can also set the pump to operate according to the maximum or minimum curve, like an uncontrolled pump:

- You can use the maximum curve mode in periods where a maximum flow rate is required. This operating mode is for instance suitable for hot-water priority.
- You can use the minimum curve mode in periods where a minimum flow rate is required. This operating mode is for instance suitable for manual night setback if automatic night setback is not desired.

You can select these two operating modes via the digital inputs.

In the control mode constant curve, you can obtain a constant flow by choosing a setpoint at 100 % and choosing the desired value for the flow rate with the $FLOW_{LIMIT}$ function. Take the accuracy of the flow rate estimation into consideration.

Additional control mode features

MAGNA3 offers additional features for the control modes to meet specific demands.

$FLOW_{LIMIT}$

The feature is an integrated part of the $FLOW_{ADAPT}$ control mode, but is also advantageous in:

- proportional-pressure mode
- constant-pressure mode
- constant-temperature mode
- constant-curve mode
- differential-temperature mode.

Characteristics and key benefits

- A control mode feature that, when activated, ensures that the rated maximum flow is never exceeded.
- By enabling $FLOW_{LIMIT}$ in systems where MAGNA3 has full authority, the rated flow is never exceeded, thus eliminating the need for throttling valves.

Technical specifications

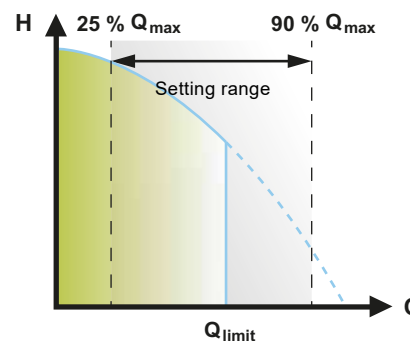

TM05 2445 1312

Fig. 28 $FLOW_{LIMIT}$

The setting range for the $FLOW_{LIMIT}$ is 25 to 90 % of the Q_{max} of the pump.

Note: Do not set the $FLOW_{LIMIT}$ lower than the dimensioned duty point.

In the flow rate range between 0 and Q_{limit} , the pump will run according to the selected control mode.

When Q_{limit} is reached, the $FLOW_{LIMIT}$ function will reduce the pump speed to ensure that the flow rate never exceeds the $FLOW_{LIMIT}$ set, no matter if the system requires a higher flow rate due to an increased resistance in the system. See figs 29, 30 and 31.

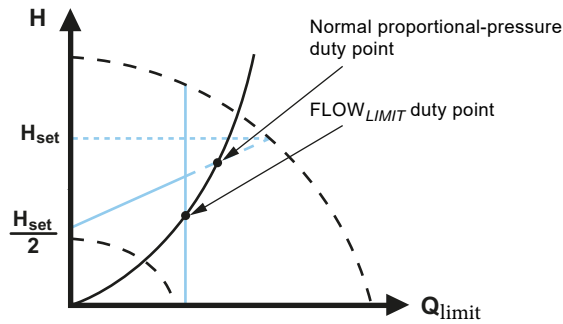

Fig. 29 Proportional-pressure control with $FLOW_{LIMIT}$

TM05 2543 0412

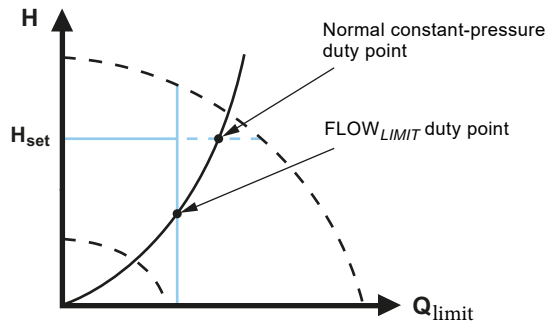

Fig. 30 Constant-pressure control with $FLOW_{LIMIT}$

TM05 2444 0312

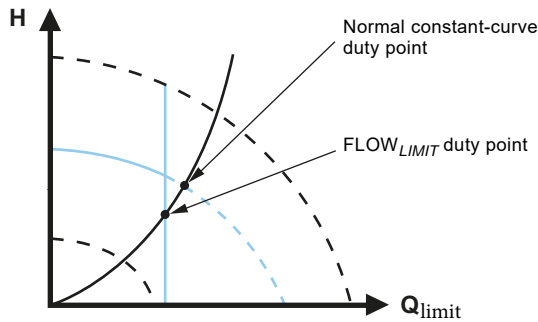

Fig. 31 Constant curve with $FLOW_{LIMIT}$

TM05 2542 0412

Automatic night setback

A night setback system is often integrated into a building management system (BMS), or as part of an equivalent electronic control system, which has a built-in timer.

The feature is not beneficial in rooms with underfloor heating because of the regulating inertia of the underfloor heating.

Characteristics and key benefits

- Automatic night setback lowers the room temperature at night, which reduces heating costs.
- The pump automatically changes between normal duty and night setback (duty at low demand), depending on the flow pipe temperature.
- Once activated, the pump runs on the minimum curve.

Technical specifications

The pump automatically changes to night setback when the built-in sensor registers a flow-pipe temperature drop of more than 18 to 27 °F (10 to 15 °C) within approximately two hours. The temperature drop must be at least 0.18 °F/min (0.1 °C/min).

Changeover to normal duty takes place without time lag when the temperature has increased by approximately 18 °F (10 °C).

Note: You cannot enable automatic night setback when the pump is in constant-curve mode.

Multipump modes

Multipump function

The multipump function enables control of single-head pumps connected in parallel and twin-head pumps without the use of external controllers. The pumps in a multipump system communicate with each other via the wireless GENair connection.

Pump system:

- Twin-head pump.
- Two single-head pumps connected in parallel. The pumps must be of equal size and type. Each pump requires a non-return valve in series with the pump.

A multipump system is set via a selected pump, i.e. the master pump (first selected pump). The multipump functions are described in the following sections.

Alternating operation

Only one pump is operating at a time. The change from one pump to the other depends on time or energy. If a pump fails, the other pump will take over automatically.

Backup operation

One pump is operating continuously. The backup pump is operated at intervals to prevent seizing up. If the duty pump stops due to a fault, the backup pump will start automatically.

Cascade operation

Cascade operation ensures that the pump performance is automatically adapted to the consumption by switching pumps on or off. The system thus runs as energy-efficiently as possible with a constant pressure and a limited number of pumps.

The slave pump starts when the master pump either runs at 90 % of the maximum speed or runs on the maximum curve.

The slave pump stops if one of the following conditions are fulfilled:

- One of the two pumps runs on minimum curve.
- One of the two pumps runs below 50 % of the maximum speed and at the same time runs below 50 % of the maximum power consumption.

Cascade operation is available in constant speed and constant pressure. You can with advantage choose a twin-head pump as the backup pump will start for a short period in peak-load situations.

All pumps in operation will run at equal speed. Pump changeover is automatic and depends on speed, operating hours and faults.

Flow estimation accuracy

The calculated flow rate has a typical accuracy of $\pm 5\%$ of Q_{max} . The less flow through the pump, the less accurate the reading will be. In worst case scenarios, such as closed valve operation, the accuracy can be up to 10 % of Q_{max} .

See also [Heat energy monitor](#), page 25.

Example:

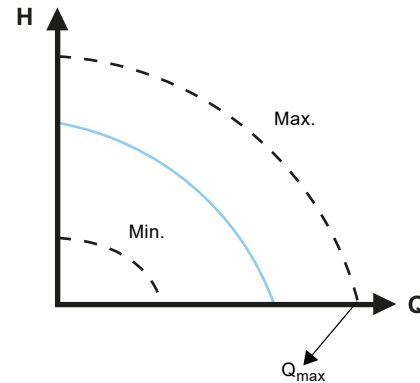

Fig. 32 Q_{max}

1. MAGNA3 65-60 has a Q_{max} of 40 m³/h. A typical 5 % accuracy means 2 m³/h inaccuracy of $Q_{max} \pm 2$ m³/h.
2. This accuracy is valid for the entire QH area. If the pump indicates 10 m³/h, the measurement is 10 ± 2 m³/h.
3. The flow rate can be 8-12 m³/h.

Note: Use of a water/ethylene glycol mixture will decrease the accuracy.

Low flow indication

The pump can experience low flow due to for example valves being shut. In cases where the flow is below 10 % of the maximum flow, thus too low for the pump's internal sensor to measure, it will be stated on the MAGNA3 display. A speed measurement will tell you that the pump is still running.

When the flow is high enough for the pump to measure, the MAGNA3 display returns to normal.

TM05 2448 5111

Readings on the pump

Performance overview

The home menu allows you to quickly gain an overview of the main settings of up to four user-defined parameters or view a graphical illustration of a QH performance curve.

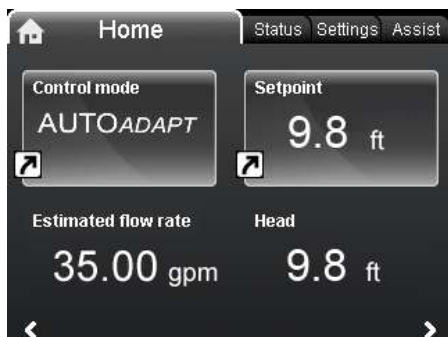

Fig. 33 Example of Home menu with overview of settings and performance

Operating status and pump performance

The status menu shows the current operating mode and the selected control mode, if any. Here, you can also review the performance of the pump:

- QH graph showing current duty point, flow rate, head, power and liquid temperature.
- "Resulting setpoint" showing the setpoint set on the pump, the external influence and the resulting setpoint.
- Liquid temperature.
- Speed.
- Operating hours.

Warning and alarm

The Warning and alarm menu provides information on:

- actual warning or alarm, if any
- information about when the warning or alarm occurred, disappeared and about corrective actions
- Warning and alarm logs.

Heat energy monitor

Heat energy monitor is a monitoring function which makes it possible to track the heat energy distribution and consumption within a system. This prevents excessive energy costs caused by system imbalances.

The pump requires a temperature sensor in the flow pipe or the return pipe. This temperature sensor is not supplied with the pump.

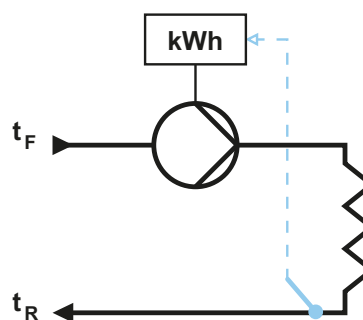

Fig. 34 MAGNA3 with built-in heat energy monitor

Note: MAGNA3 incorporates a calculator for flow and media temperature, see [External Grundfos sensors](#), page 65.

Heat consumption accuracy

The built-in flow estimation needed for the calculation has a typical accuracy of $\pm 5\%$ of Q_{max} . The less flow through the pump, the less accurate the reading will be. In worst case scenarios such as closed valve operation, the accuracy can be up to 10% of Q_{max} . The actual accuracy in a duty point will be shown in the MAGNA3 display (this feature is available for pumps with production code from 1838).

The temperature measurement accuracy also depends on the sensor type. Therefore, you cannot use the heat energy value for billing purposes. However, the value is perfect for optimisation purposes in order to prevent excessive energy costs. See also [Readings on the pump](#), page 25.

To counterbalance any inaccuracy on either the internal and external sensor, it is possible to manually enter a temperature offset. The offset is entered in integers, for example 2 degrees.

Note: Temperature sensor offset is available for pumps with production code from 1838.

Operating log

The Operating log is the perfect tool for pump optimization, replacement and fault finding as it offers the following:

- All duty points and operating conditions are tracked and stored in the pump.
- The 3D work log and duty curve (over time) provide instant overviews of historical pump performance and operating conditions.

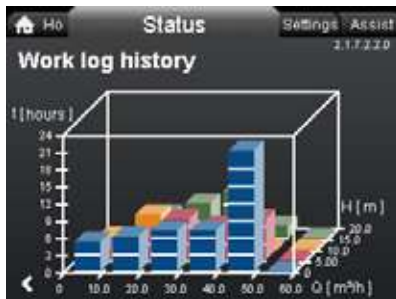

Fig. 35 Example of Operating log

Help and guidance

The Assist menu guides you through the setup of the pump and offers the following:

- step-by-step instructions in how to set the pump
- a short description of the six control modes and recommended applications
- assistance with fault correction
- fault advice
- multipump setup
- setup, analog input
- description of control mode.

Grundfos Eye

Grundfos Eye at the top of the operating panel is a pump status indicator light providing information about the pump operating status.

The indicator light will flash in different sequences and provide information about the following:

- power on or off
- pump warnings
- pump alarms
- remote control
- pump running or stopped.

The function of Grundfos Eye is described in detail in the installation and operating instructions.



Fig. 36 Grundfos Eye

Communication

MAGNA3 enables communication via the following:

- wireless Grundfos GO
- fieldbus communication via CIM modules
- digital inputs
- relay outputs
- analog input.

Grundfos GO Remote

With Grundfos GO Remote, you can monitor your pump, change settings, collect data and make reports.

A user-friendly interface provides you with all the information and help you need, as well as live pump data monitoring and easy-to-follow tips and guides.

For further details, see [Grundfos GO Remote](#), page 64.

TM05 3810 1612

Wireless GENIair

The pump is designed for multipump connection via the wireless GENIair connection.

The built-in wireless GENIair module enables communication between pumps and with Grundfos GO without the use of add-on modules:

- Multipump function.
See [Multipump function](#), page 24.
- Grundfos GO.
See [Grundfos GO Remote](#), page 64.

CIM modules



TM05 3811 1612





Fig. 37 Grundfos CIM modules



A CIM module is an add-on Communication Interface Module. The CIM module enables data transmission between the pump and an external system, for example a BMS (Building Management System) or SCADA system.

The CIM module communicates via fieldbus protocols.

See [Available CIM modules](#), page 28.

Available CIM modules

Module	Fieldbus protocol	Description	Functions
<p>CIM 050</p> 	<p>GENIbus</p> <p>TM06 7238 3416</p>	<p>CIM 050 is a Grundfos communication interface module used for communication with a GENIbus network.</p>	<p>CIM 050 has terminals for the GENIbus connection.</p>
<p>CIM 100</p> 	<p>LonWorks</p> <p>TM06 7279 3416</p>	<p>CIM 100 is a Grundfos communication interface module used for communication with a LonWorks network.</p>	<p>CIM 100 has terminals for the LonWorks connection.</p> <p>Two LEDs are used to indicate the actual status of the CIM 100 communication. One LED is used for indication of correct connection to the pump, and the other is used to indicate LonWorks communication status.</p>
<p>CIM 200</p> 	<p>Modbus RTU</p> <p>TM06 7281 3416</p>	<p>CIM 200 is a Grundfos communication interface module used for communication with a Modbus RTU network.</p>	<p>CIM 200 has terminals for the Modbus connection.</p> <p>DIP switches are used to select parity and stop bits, to select transmission speed and to set line termination.</p> <p>Two hexadecimal rotary switches are used to set the Modbus address.</p> <p>Two LEDs are used to indicate the actual status of the CIM 200 communication. One LED is used for indication of correct connection to the pump, and the other is used to indicate Modbus communication status.</p>
<p>CIM 260</p> 	<p>US 3G/4G</p>	<p>CIM 260 is a Grundfos communication interface module, which communicates using Modbus TCP via cellular data transmission to a SCADA system or SMS communication to mobile phones.</p>	<p>CIM 260 has a SIM-card slot and an SMA connection to the cellular antenna.</p> <p>CIM 260 can be fitted with a lithium-ion battery.</p> <p>Two LEDs are used to indicate the actual status of the CIM 260 communication. One LED is used for indication of correct connection to the pump, and the other is used to indicate cellular communication status.</p> <p>Note: The SIM card is not supplied with CIM 260.</p>
<p>CIM 280</p> 	<p>GRM 3G/4G</p>	<p>CIM 280 is a Grundfos communication interface module which communicates via cellular network to Grundfos Remote Management.</p>	<p>CIM 280 has a SIM-card slot and an SMA connection to the cellular antenna.</p> <p>CIM 280 can be fitted with a lithium-ion battery.</p> <p>Two LEDs are used to indicate the actual status of the CIM 260 communication. One LED is used for indication of correct connection to the pump, and the other is used to indicate cellular communication status.</p> <p>Note: The SIM card is not supplied with CIM 280.</p>

Module	Fieldbus protocol	Description	Functions
<p>CIM 300</p> 	<p>BACnet MS/TP</p> <p>TM06 7281 3416</p>	<p>CIM 300 is a Grundfos communication interface module used for communication with a BACnet MS/TP network.</p>	<p>CIM 300 has terminals for the BACnet MS/TP connection. DIP switches are used to set transmission speed and line termination and to select the custom Device Object Instance Number. Two hexadecimal rotary switches are used to set the BACnet address. Two LEDs are used to indicate the actual status of the CIM 300 communication. One LED is used for indication of correct connection to the pump, and the other is used to indicate BACnet communication status.</p>
<p>CIM 500</p> 	<p>Ethernet</p> <p>TM06 7283 3416</p>	<p>CIM 500 is a Grundfos communication interface module used for data transmission between an industrial Ethernet network and a Grundfos product. CIM 500 supports various industrial Ethernet protocols:</p> <ul style="list-style-type: none"> • PROFINET • Modbus TCP • BACnet/IP • Ethernet/IP • GRM IP • Grundfos iSolutions Cloud (GiC). 	<p>CIM 500 supports various industrial Ethernet protocols. CIM 500 is configured via the built-in web server. CIM 500 is configured via the built-in web server, using a standard web browser on a PC. See the specific functional profile on the DVD-ROM supplied with the Grundfos CIM module.</p>

For product numbers, see [CIM modules](#), page 63.

Grundfos Remote Management

Grundfos Remote Management is an easy-to-install, low-cost solution for wireless monitoring and management of Grundfos products. GRM is based on a centrally hosted database and a web server with wireless data collection via GSM/GPRS modem. The system only requires an internet connection, a web browser, a GRM modem and an antenna as well as a contract with Grundfos allowing you to monitor and manage Grundfos pump systems.

You have wireless access to your account anywhere and anytime you have an internet connection, for example via a smartphone, tablet PC, laptop or computer. Warnings and alarms can be sent by email or SMS to your mobile phone or computer.

For information about the CIM communication interface module and GSM antennas, see [Grundfos Remote Management](#), page 131.

Digital inputs

You can use the digital input for external control of start or stop or forced maximum or minimum curve.

Note: If no external on and off switch is connected, maintain the jumper between the Start/Stop (S/S) and frame (\perp) terminals. This connection is the factory setting.

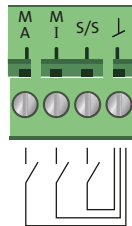
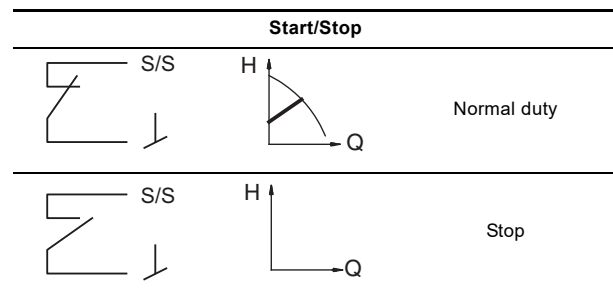

Fig. 38 Digital input in control box

Contact symbol	Function
M A	Maximum curve
M I	Minimum curve
S/S	Start/Stop
\perp	Frame connection

External start or stop

You can start and stop the pump via the digital input.



External forced maximum or minimum curve

You can force the pump to operate on the maximum or minimum curve via the digital input.

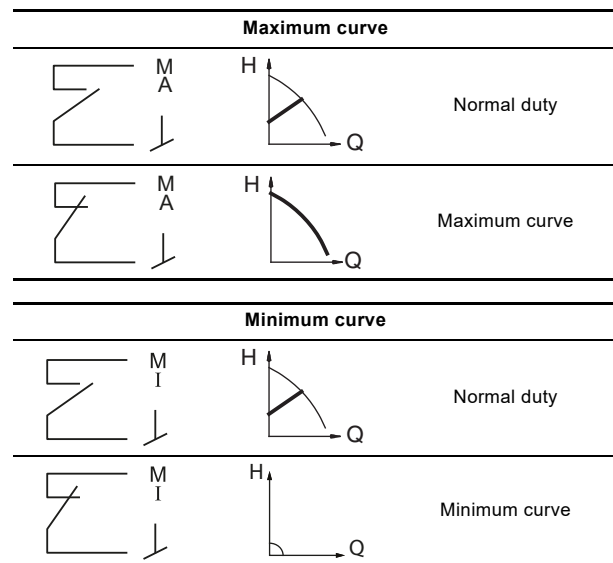

TM05 3343 1212

Relay outputs

The pump has two signal relays with a potential-free changeover contact for external fault indication. You can set the function of the signal relay to Alarm, Ready or Operation on the pump operating panel or with Grundfos GO.

Factory settings of relays:

Relay	Function
1	Operation signal
2	Alarm signal

Note: You can configure both relays to "ready, alarm or operating".

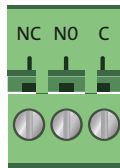

Fig. 39 Relay output in the control box

TM05 3343 1212

Contact symbol	Function
NC	Normally closed
NO	Normally open
C	Common

The functions of the signal relays are as shown in the table below:

Signal relay	Alarm signal
	Not activated: <ul style="list-style-type: none"> The power supply has been switched off. The pump has not registered a fault.
	Activated: <ul style="list-style-type: none"> The pump has registered a fault.
Signal relay	Ready signal
	Not activated: <ul style="list-style-type: none"> The pump has registered a fault and is unable to run.
	Activated: <ul style="list-style-type: none"> The pump has been set to stop, but is ready to run. The pump is running.
Signal relay	Operating signal
	Not activated: <ul style="list-style-type: none"> The pump is not running.
	Activated: <ul style="list-style-type: none"> The pump is running.

Analog input for an external sensor

To optimize pump performance, you can use the analog input for the connection of an external sensor in the following cases:

Function/control mode	Sensor type
Heat energy monitor	
Constant temperature	Temperature sensor
Differential temperature	
Constant pressure	Differential-pressure transmitter

Controlling the flow in the system

When using an external differential-pressure sensor to control the flow in the system, you obtain the externally set pressure, which results in the following benefits:

- minimizes operating costs
- prevents valve noise
- ensures comfort (adequate pressure).

When setting this function, make sure that the pump is set to run in constant-pressure mode and that "Differential-pressure control" has been activated in the "Analog input" menu on the pump's operating panel.

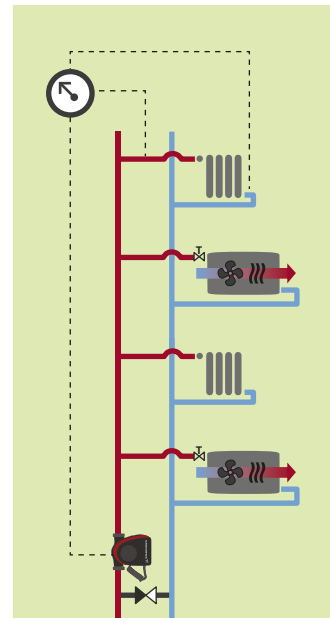

Fig. 40 External differential-pressure sensor

TM07 0361 1218

The electrical signal for the input can be 0-10 V or 4-20 mA. You can change the selection of the electrical signal (0-10 V or 4-20 mA) on the operating panel or with Grundfos GO.

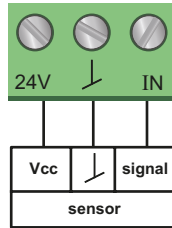

Fig. 41 Analog input for an external sensor or control

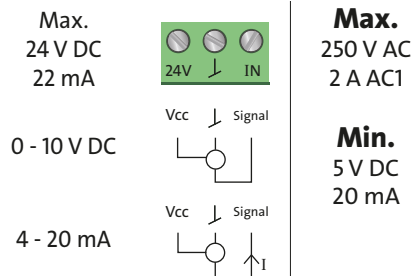

Fig. 42 Wiring, analog input

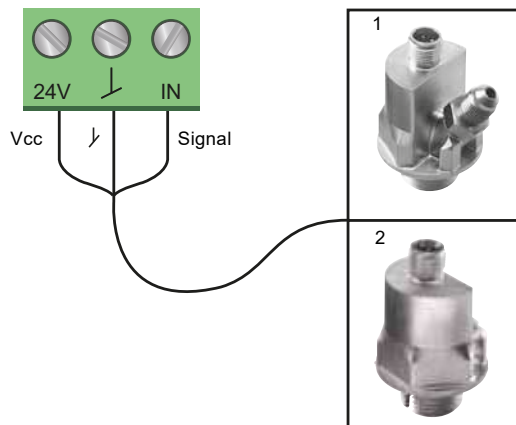

Fig. 43 Examples of external sensors

Pos.	Sensor type
1	Differential-pressure transmitter, Grundfos type DPI V.2 1/2" connection and 4-20 mA signal.
2	Relative-pressure transmitter. Combined temperature and pressure sensor, Grundfos type RPI T2. 1/2" connection and 0-10 V signal.

For further details, see [External Grundfos sensors](#), page 65.

External control system

The analog input can be used for an external signal for the control from a BMS system or similar control system.

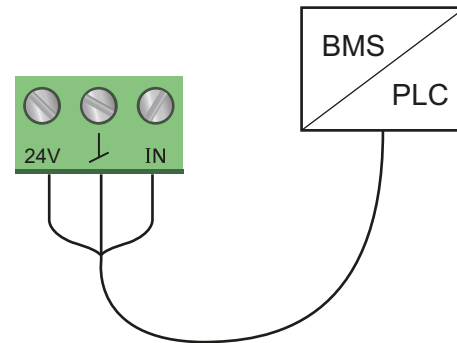

Fig. 44 Example of an external signal for the control via BMS or PLC

External setpoint function

You can use the analog input to influence the setpoint externally.

The external setpoint function can be used in two different ways:

- Linear with Min.
- Linear with Stop (available for pumps with production code from 1838)

In both modes the input signal range is influenced linearly.

Linear with Min.

Here, a 0-10 V or 4-20 mA signal controls the pump speed range in a linear function. The range of control depends on the minimum speed, power and pressure limits of the pump. See figs 45 and 46.

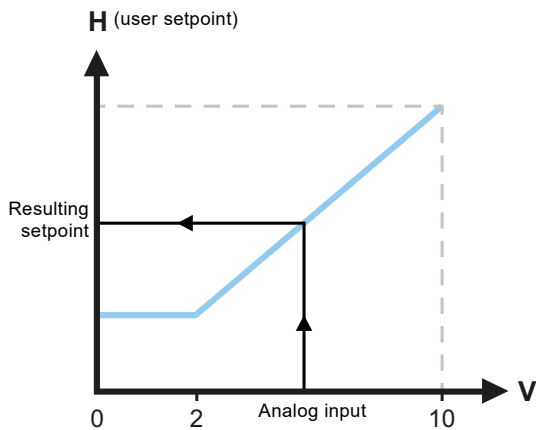

Fig. 45 Linear with Min., 0-10 V

TM06 9149 2117

Control

0-2 V (0-20 %)	Resulting setpoint is equal to minimum.
2-10 V (20-100 %)	Resulting setpoint is between minimum and user setpoint.

Fig. 46 Control range and setpoint

Linear with Stop

Note: Available for pumps with production code from 1838.

Here, if the input signal is below 10 %, the pump changes to operating mode "Stop". If the input signal is increased above 15 %, the operating mode is changed back to "Normal".

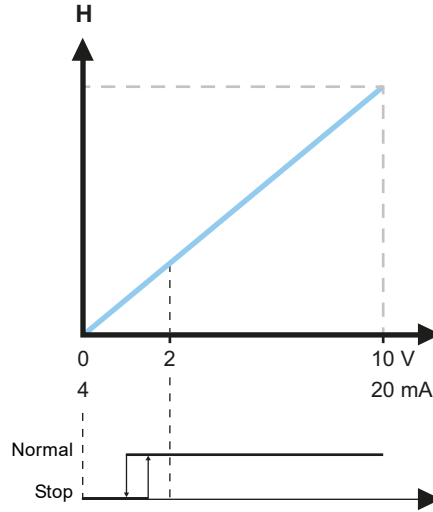

Fig. 47 "Linear with Stop", 0-10 V

TM06 9149 2117

External setpoint function according to model

The external setpoint function operates differently, depending on the model. For model A,B and C, the maximum speed is often obtained at voltages lower than 10 V as the span of control is limited.

In models newer than A,B, and C, the internal scaling has been optimised making the dynamic area bigger, thus giving a better control of the pump speed when using the external setpoint function.

The same applies if the pump is receiving a set point from Building Management Systems.

5. Operating conditions

General recommendations

Water in heating systems	Water quality according to local standards
Domestic hot water	Degree of hardness up to 14 °dH
Water containing glycol	Maximum viscosity = 10-50 cSt ~ 50 % water and 50 % ethylene glycol at +14 °F (-10 °C)

Liquid temperature

Application	Temperature range
General	+14 to +230 °F (-10 to +110 °C)
Domestic hot-water systems	Up to 149 °F (65 °C) recommended

In cooling applications condensation may occur on the surface of the pump. In certain cases it is necessary to mount a drip tray.

Location

The pump is designed for indoor installation.

Always install the pump in a dry environment where it will not be exposed to drops or splashes, for example water, from surrounding equipment or structures.

As the pump contains stainless-steel parts, it is important that it is not installed directly in environments, such as:

- Indoor swimming pools where the pump would be exposed to the ambient environment of the pool.
- Locations with direct and continuous exposure to a marine atmosphere.
- In rooms where hydrochloric acid (HCl) can form acidic aerosols escaping from, for example, open tanks or frequently opened or vented containers.

The above applications do not disqualify for installation of MAGNA3. However, it is important that the pump is not installed directly in these environments.

Ambient conditions

Ambient conditions	
Ambient temperature during operation	-4 to 104 °F (-20 to 40 °C)
Ambient temperature during storage and transport	-40 to 158 °F (-40 to +70 °C)
Relative humidity	Maximum 95 %

Ambient temperatures below 0 °C require the following conditions:

- The media temperature is +5 °C
- The media contains glycol
- The pump runs continuously and does not stop
- For twin-head pumps cascade operation every 24 h is mandatory.

Maximum operating pressure

PN 6: 87 psi (6 bar / 0.6 MPa)

PN 10: 145 (10 bar / 1.0 MPa)

PN 12: 175 psi (12 bar / 1.2 MPa)

Note: Not all variants are available in all markets.

Test pressure

The pumps can withstand test pressures as indicated in EN 60335-2-51. See below.

- PN 6: 104.4 psi (7.2 bar / 0.72 MPa)
- PN 10: 175 psi (12 bar / 1.2 MPa)
- PN 6/10: 175 psi (12 bar / 1.2 MPa)
- PN 12: 175 psi (12 bar / 1.2 MPa).

Not all variants are available in all markets.

During normal operation, do not use the pump at higher pressures than those stated on the nameplate.

The pressure test has been made with water containing anticorrosive additives at a temperature of 68 °F (20 °C).

Minimum inlet pressure

The following relative minimum pressure must be available at the pump inlet during operation to avoid cavitation noise and damage to the pump bearings.

The values in the table below apply to single-head pumps and twin-head pumps in single-head operation.

MAGNA3	Liquid temperature		
	167 °F (75 °C)	203 °F (95 °C)	230 °F (110 °C)
	Inlet pressure [psi (bar)]		
25-40/60/80/100/120	1.5 (0.10)	5 (0.35)	14.5 (1.0)
32-40/60/80/100/120	1.5 (0.10)	5 (0.35)	14.5 (1.0)
32-40/60/80/100/120 F	1.5 (0.10)	5 (0.35)	14.5 (1.0)
32-120 F	1.5 (0.10)	2.9 (0.2)	10.15 (0.7)
40-40/60 F	1.5 (0.10)	5 (0.35)	14.5 (1)
40-80/100/120/150/180 F	1.5 (0.10)	7.25 (0.5)	14.5 (1)
50-40/60/80 F	1.5 (0.10)	5.8 (0.4)	14.5 (1)
50-100/120 F	1.5 (0.10)	7.25 (0.5)	14.5 (1)
50-150/180 F	10.15 (0.70)	17.4 (1.2)	24.66 (1.7)
65-40/60/80/100/120/150 F	10.15 (0.70)	17.4 (1.2)	24.66 (1.7)
80-40/60/80/100/120 F	7.25 (0.50)	14.5 (1.0)	21.76 (1.5)
100-40/60/80/100/120 F	10.15 (0.70)	17.4 (1.20)	24.66 (1.7)

Note: Not all variants are available in all markets.

In the case of cascade twin-head operation, increase the required relative inlet pressure by 1.45 psi (0.1 bar, 0.01 MPa) compared to the stated values for single-head pumps or twin-head pumps in single-head operation.

Note: The actual inlet pressure plus pump pressure against a closed valve must be lower than the maximum permissible system pressure.

The relative minimum inlet pressures apply to pumps installed up to 984 ft (300 meters) above sea level. For altitudes above 984 ft (300 meters), increase the required relative inlet pressure by 0.145 psi (0.01 bar, 0.001 MPa) per 328 ft (100 meters) altitude. The MAGNA3 pump is only approved for an altitude of 6560 ft (2000 meters).

Closed valve operation

MAGNA3 pumps can operate at any speed against a closed valve for several days without damage to the pump. However, Grundfos recommends you to operate at the lowest possible speed curve to minimise energy losses. There are no minimum flow requirements.

Note: Do not close inlet and outlet valves simultaneously, always keep one valve open when the pump is running to avoid pressure buildup. Media and ambient temperatures must never exceed the specified temperature range.

Pumped liquids

The pump is suitable for thin, clean, non-aggressive and non-explosive liquids, not containing solid particles or fibers that may attack the pump mechanically or chemically. In heating and cooling systems, the water must meet the requirements of accepted standards, codes, and any authority having jurisdiction (AHJ) requirements.

In domestic hot-water systems, we recommend that you use MAGNA3 pumps only for water with a degree of hardness lower than approximately 14 °dH.

In domestic hot-water systems, we recommend that you keep the liquid temperature below 149 °F (65 °C) to eliminate the risk of lime precipitation.

You can use MAGNA3 pumps for pumping water and glycol mixtures up to 50 %.

Example of a water and ethylene glycol mixture:

Maximum viscosity: 10-50 cSt ~ 50 % water and 50 % ethylene glycol mixture at +14 °F (10 °C).

The pump is controlled by a power-limiting function that protects against overload.

The pumping of glycol mixtures will affect the maximum curve and reduce the performance, depending on the water and ethylene glycol mixture and the liquid temperature.

To prevent the ethylene glycol mixture from degrading, avoid temperatures exceeding the rated liquid temperature and minimize the operating time at high temperatures.

You must clean and flush the system before the ethylene glycol mixture is added.

To prevent corrosion or lime precipitation, maintain the ethylene glycol mixture regularly. If further dilution of the supplied ethylene glycol is required, follow the glycol supplier's instructions.

Electrical data

Pump type	MAGNA3 (D)
Enclosure class	Type 2
Insulation class	F.
Supply voltage	1 x 115-230 V ± 10 %, 60 Hz*, PE. M20 cable gland (supplied with the pump).
Three digital inputs	External potential-free contact. Contact load: 5 V, 10 mA. Screened cable. M16 cable gland (not supplied with the pump). Loop resistance: Maximum 130 Ω.
Analog input	4-20 mA (load: 150 Ω). 0-10 VDC (load: > 10 kΩ).
Two relay outputs	Internal potential-free changeover contact. Maximum load: 250 V, 2 A, AC1. Minimum load: 5 VDC, 20 mA. Screened cable, depending on signal level. M16 cable gland (not supplied with the pump).
Bus input	Grundfos Communication Interface Modules (add-on CIM modules) for: <ul style="list-style-type: none"> • GENibus • LonWorks+ • Modbus RTU • BACnet MS/TP • GSM/GPRS • Grundfos Remote Management • Ethernet.
Leakage current	$I_{leakage} < 3.5$ mA. The leakage currents are measured in accordance with EN 60335-1.
EMC	Standards used: EN 55014-1:2006 + A1:2009 + A2:2011, EN 55014-1:2017, EN 61000-6-2:2005, EN 61000-3-3:2013, EN 61000-3-2:2014.
Cos φ	Terminal-connected versions have a built-in active PFC (Power Factor Control) which gives a cos φ from 0.98 to 0.99, i.e. very close to 1. Wire-to-wire versions have no PFC and therefore the power factor is from 0.50 to 0.99.
Consumption when the pump is stopped	4 to 10 W, depending on activity, i.e. reading the display, use of Grundfos GO, interaction with modules, etc. 4 W, when the pump is stopped and there is no activity.

* All MAGNA3 pumps are approved to run on both 50 and 60 Hz.

Sound pressure level

The sound pressure level of the pump is dependent on the power consumption. Levels are determined in accordance with ISO 3745 and ISO 11203, method Q2.

Pump size	Maximum dB(A)
25-40/60/80/100/120	39
32-40/60/80/100/120	
40-40/60	
50-40	45
32-120 F	
40-80/100	
50-60/80	
65-40/60	50
80-40	
40-120/150/180	
50-100/120/150/180	
65-80/100/120	55
80-60/80	
100-40/60	
65-150	55
80-100/120	
100-80/100/120	

Note: Not all variants are available in all markets.

6. Construction

MAGNA3 is of the canned-rotor type, i.e. the pump and motor form an integral unit without shaft seal and with only two gaskets for sealing. The bearings are lubricated by the pumped liquid.

The pump is characterized by the following:

- controller integrated in the control box
- operating panel on the control box
- control box prepared for optional CIM modules
- built-in differential-pressure and temperature sensor
- cast-iron or stainless-steel pump housing
- twin-head versions
- no external motor protection required
- insulating shells supplied with single-head pumps for heating systems.

Motor and electronic controller

MAGNA3 incorporates a 4-pole synchronous, permanent-magnet motor (PM motor). This motor type is characterized by higher efficiency than a conventional asynchronous squirrel-cage motor.

The pump speed is controlled by an integrated variable frequency drive.

Differential-pressure and temperature sensor

The differential-pressure and temperature sensor is located in the pump housing in a channel between the inlet and outlet ports.

Via a cable, the sensor sends an electrical signal for the differential pressure across the pump and for the liquid temperature to the controller in the control box.

The sensor offers substantial benefits:

- direct feedback on the pump display
- complete pump control
- measurement of the pump workload for precise and optimum control resulting in higher energy efficiency.

Sensor specifications, temperature

Temperature range during operation	Accuracy
14 to 95 °F (-10 to +35 °C)	± 4 °F (± 2 °C)
95 to 194 °F (35 to 90 °C)	± 2 °F (± 1 °C)
194 to 230 °F (90 to 110 °C)	± 4 °F (± 42 °C)

Pump connections

Threaded pipe connections according to ISO 228-1.
Flange dimensions to EN 1092-2.

Surface treatment

The pump housing and pump head are electrocoated to improve corrosion resistance.

Electrocoating includes:

- alkaline cleaning
- pretreatment with zinc phosphate coating
- cathodic electrocoating (epoxy)
- curing of paint film at 392 to 482 °F (200 to 250 °C).

The pump housing of stainless-steel versions is not treated or painted and appears in blank steel. See fig. 48.



TM06 0140 4913

Fig. 48 MAGNA3 stainless steel version

Color

Color codes for the pump:

Color	Code
Red	NCS40-50R
Black	NCS9000

Sectional drawing

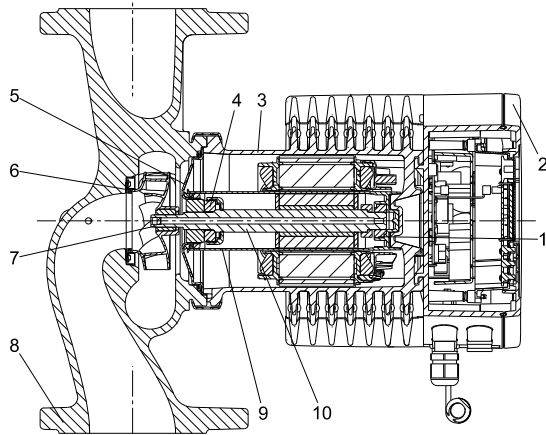

Fig. 49 Terminal-connected version

TM05 2319 0312

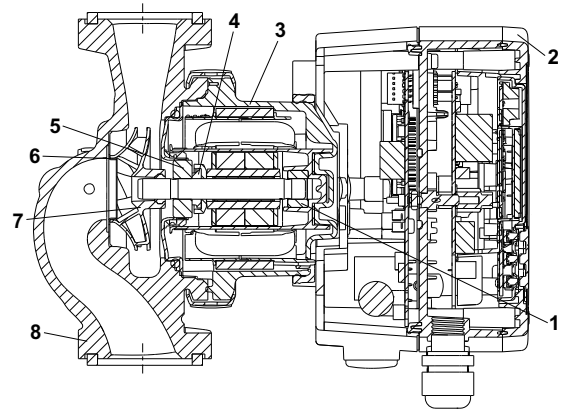

Fig. 50 Wire-to-wire-connected version

TM07 1970 2518

Material specification

See fig. 49.

Pos.	Component	Material	Grade
1	Outer bearing ring	Aluminium oxide	
2	Control box	Polycarbonate	
3	Stator housing	Aluminium	
	O-rings	EPDM	
4	Thrust bearing	Aluminium oxide/carbon	
5	Bearing plate	Stainless steel	AISI 304 (EN 1.4301)
6	Neck ring	Stainless steel	AISI 304 (EN 1.4301)
7	Impeller	PES	
8	Pump housing	Cast iron/stainless steel	ASTM A48 class 35B/AISI 316 (EN 1561 EN-GJL-250/EN 1.4308)
9	Rotor can	PPS	
10	Shaft	Ceramic (wire-to-wire-connected versions)	
10	Shaft	Stainless steel (terminal-connected versions)	AISI 316L (EN 1.4404)

Sensor drawing

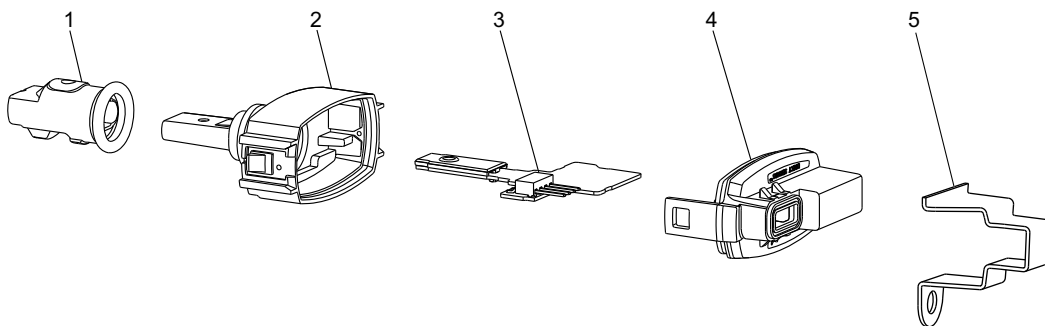

Fig. 51 Sensor

TM06 9250 2117

Pos.	Component	Material	Grade
1	Sealing cap	EPDM	
2	Housing	PPS	
3	Printed-circuit board	-	
4	Cover snap-on	PA/TPV	
5	Bracket for sensor	Stainless steel	AISI 304 (EN 1.4301)

7. Installation

Mechanical installation

MAGNA3 is designed for indoor installation. You must install the pump with horizontal motor shaft. You can install the pump in horizontal as well as vertical pipes.

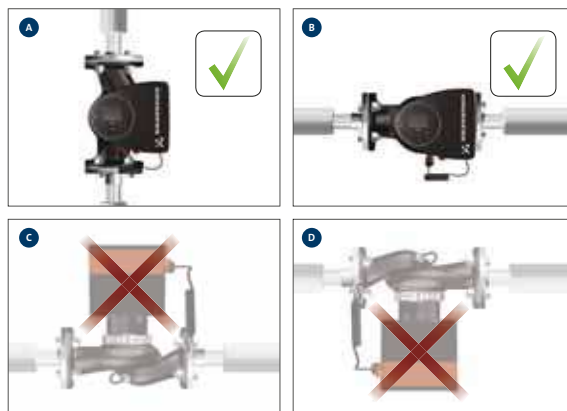

Fig. 52 Installation positions

Arrows on the pump housing indicate the liquid flow direction through the pump.

The control box must be in horizontal position with the Grundfos logo in vertical position. See fig. 52.

You must install the pump in such a way that it is not stressed by the pipes.

The pump may be suspended directly in the pipes, provided that the pipes can support the pump.

Twin-head pumps are prepared for installation on a mounting bracket or base plate.

To ensure adequate cooling of motor and electronics, observe the following:

- Position the pump in such a way that sufficient cooling is ensured.
- The temperature of the ambient air must not exceed 104 °F ° (40 °C).

Insulating shells

The insulating shells supplied with single-head MAGNA3 pumps are for heating systems and must be fitted as part of the installation.

Insulating shells for applications with ice buildup are available as an accessory.

See [Insulating kits for applications with ice buildup](#), page 63.

Note: Insulating shells are not available for twin-head pumps.

Insulating shells increase the pump dimensions.

Electrical installation

The electrical connection and protection must be carried out in accordance with local regulations.

- The pump must be connected to an external main switch.
- The pump must always be correctly grounded.
- The pump requires no external motor protection.
- The pump incorporates thermal protection against slow overloading and blocking.
- When switched on via the power supply, the pump will start pumping after approximately 5 seconds.

Note: The number of starts and stops via the power supply must not exceed four times per hour.

The pump has a digital input that you can use for external control of start/stop without switching the power supply on and off.

Make the pump mains connection as shown in the diagrams on the following pages.

If rigid conduit is to be used, the hub must be connected to the conduit system before it is connected to the terminal box of the pump.

Cables

Use screened cables for the external on and off switch, the digital input, sensor and setpoint signals.

All cables used must be heat-resistant up to at least 158 °F (70 °C.)

All cables used must be installed in accordance with the National Electrical Code, or in Canada, Canadian Electrical Code, and state and local regulations.

Additional protection

Ground fault circuit interrupter (GFCI)

Use a suitable type of GFCI capable of handling ground fault currents with a DC content (pulsating DC). If the pump is connected to an electrical installation where a GFCI is used for additional protection, this GFCI must be able to trip when ground fault currents with DC content occur.

Connection to power supply, terminal-connected versions

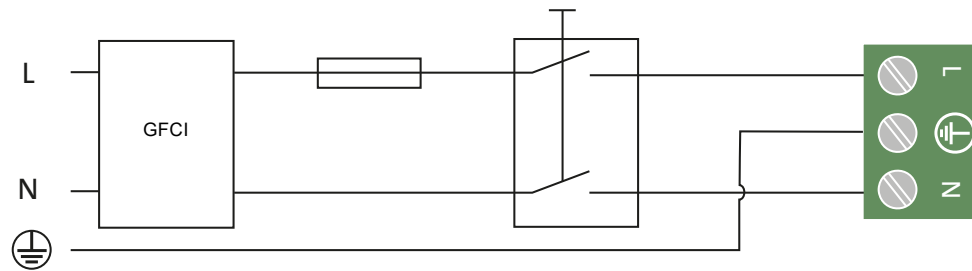

Fig. 53 Example of a terminal-connected motor with main switch, backup fuse and additional protection

TM03 2397 3216

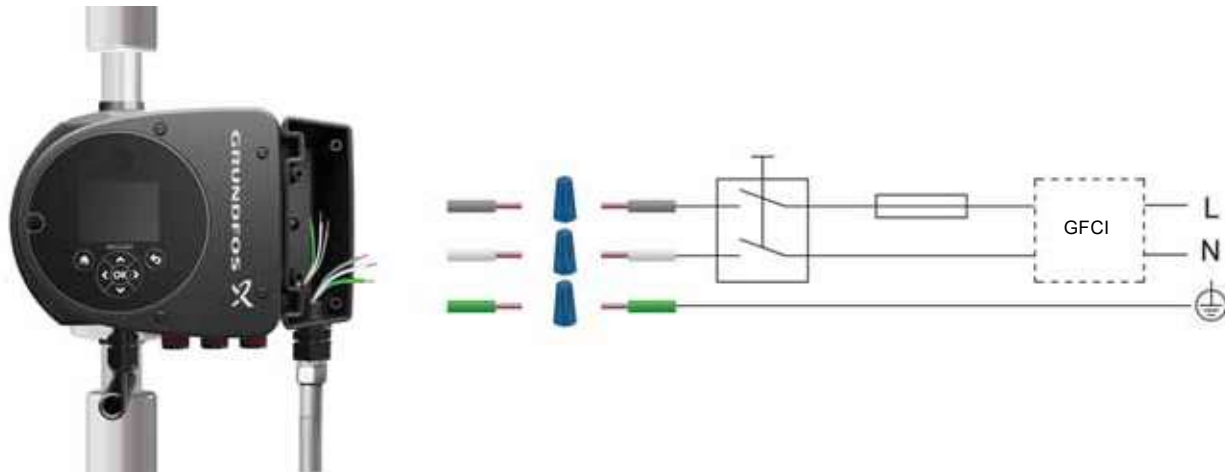

Fig. 54 Example of electrical connections for models with wire-to-wire connections

TM071415 1618

Use a suitable type of GFCI capable of handling ground fault currents with a DC content (pulsating DC). If the pump is connected to an electrical installation where a GFCI is used for additional protection, this GFCI must be able to trip when ground fault currents with DC content occur.

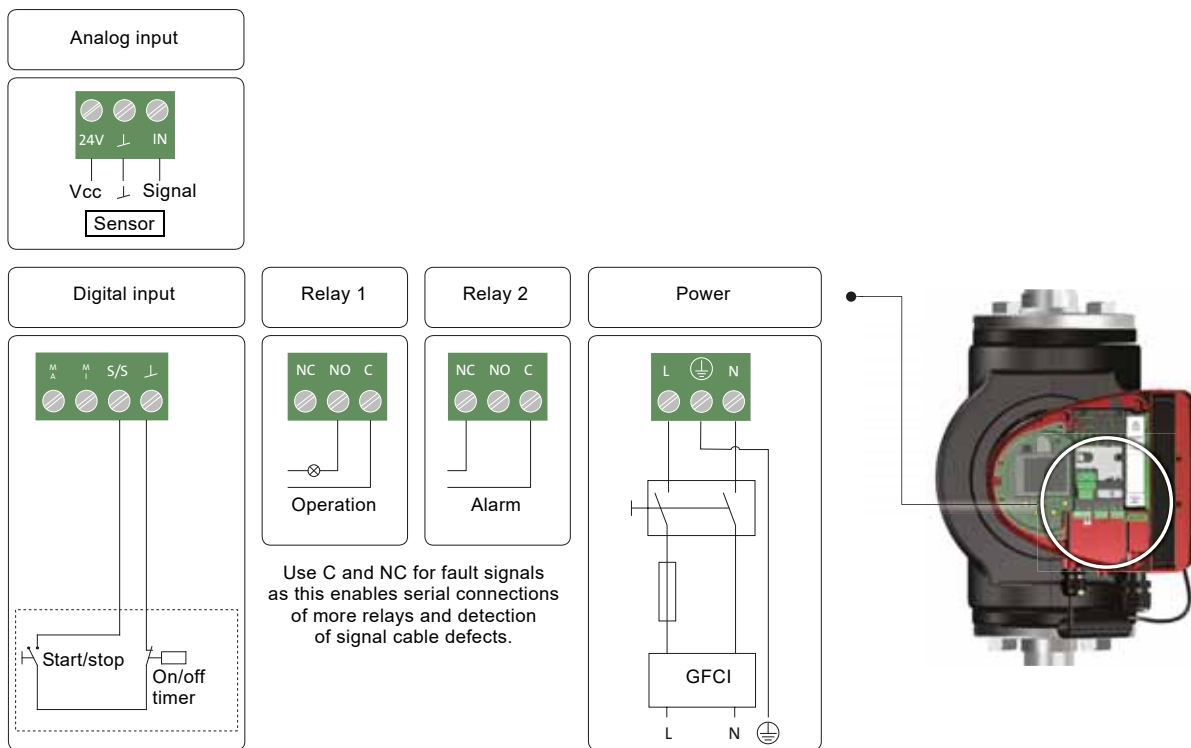

Fig. 55 Example of connections in the control box of terminal-connected versions

TM07 0364 1518

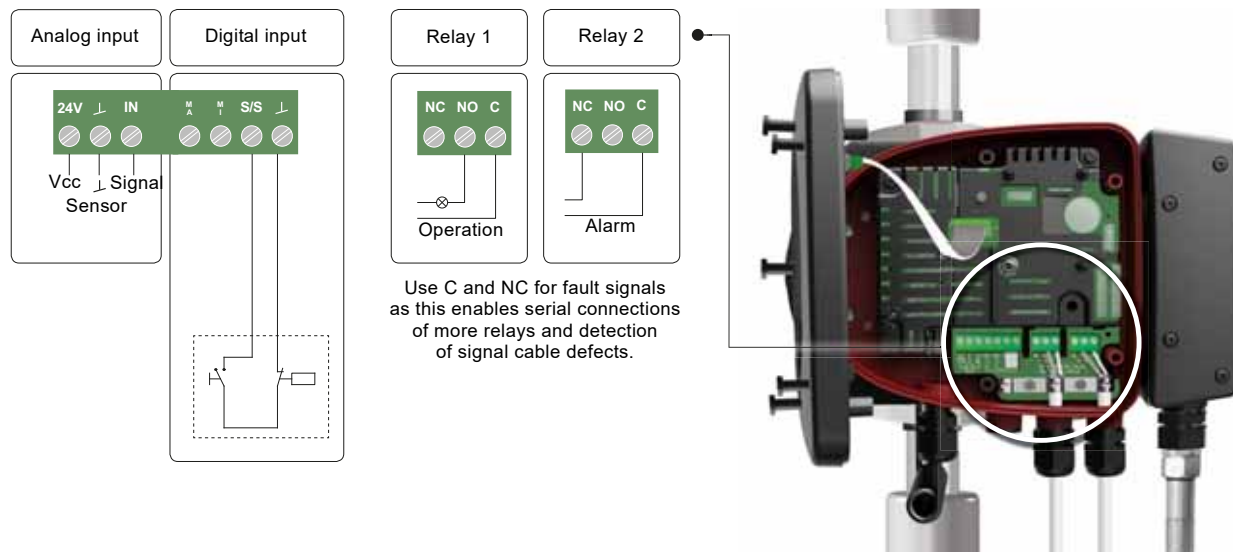

Fig. 56 Example of connections in the control box of wire-to-wire connected versions

TM07 1623 1918

For further information on digital and analog inputs, see [Digital inputs](#), page 30, and [Analog input for an external sensor](#), page 31.

For information on relay outputs, see [Relay outputs](#), page 31.

For details on how to install and operate the MAGNA3 pumps, please see the MAGNA3 model D - Installation and operating instructions:



net.grundfos.com/qr/i/99332342

8. Operating the product

MAGNA3 can be operated and monitored via the operating panel on the pump and via the Grundfos GO Remote app.

Operating panel

The MAGNA3 pump range allows you to set the pump directly on the user-friendly, 4" TFT operating panel with self-explanatory push-buttons made of high-quality silicone for precise navigation.

The operating panel gives quick and easy access to pump and performance data on site. The menu includes all available MAGNA3 pump settings, such as control mode, setpoint, relay output and bus communication.

Startup guide and assistance

When you start the pump for the first time, you are presented with a startup guide enabling easy setting of the pump. Additionally, the "Assist" menu, including the application wizard, guides you through the various settings of the pump.



Fig. 57 Operating panel, startup guide

Application wizard

The application wizard helps you to set the correct control mode according to your application. The wizard can be accessed via the startup guide and the "Assist" menu.

Starting with the overall application type, e.g. radiator, and then specifying the system setup step by step, the wizard identifies the best suited control mode and, if necessary, helps you set the duty point.

The Display menu overview booklet provided with the pump includes application overviews such as the ones shown in 3. [System applications](#). Using these, you can quickly identify the pump in your system and apply this knowledge directly to the wizard on the pump.



TM07 1487 4818

Grundfos GO Remote

The pump communicates wirelessly with Grundfos GO Remote, which allows you to:

- read operating data such as flow rate, liquid temperature and energy consumption
- read out warnings and alarms
- set the control mode and setpoint
- select external setpoint signal
- select function for digital input
- set up multipump systems
- allocate the pump number making it possible to distinguish between pumps that are connected via Grundfos GENIbus
- generate pdf reports with operating data, pump setup and warnings and alarms history.

Furthermore, Grundfos GO Remote includes assisted pump setup and assisted fault advice.



TM05 3825 2017

9. Curve conditions

Performance curves

The guidelines below apply to the performance curves on pages 45 to 62:

- Test liquid: airless water.
- The curves apply to a density of $\rho = 983.2 \text{ kg/m}^3$ and a liquid temperature of 140 °F (60 °C).
- All curves show average values. If a specific minimum performance is required, individual measurements must be made.
- The curves apply to a kinematic viscosity of $\mu = 0.474 \text{ mm}^2/\text{s}$ (0.474 cSt).
- Reference supply voltage: 1 x 230 V, 50 Hz.

Note: Within the MAGNA3 performance range, you can set the constant- and proportional-pressure curves in steps of 0.1 m head on the operating panel or with Grundfos GO.

QR code on the pump nameplate



TM05 3826 2017



Fig. 58 QR code on the pump nameplate

With Grundfos GO or a smartphone, you get the following information about MAGNA3:

- product photo
- pump performance curves
- dimensional sketches
- wiring diagram
- quotation text
- technical data
- service parts list
- PDF files, such as data booklet and installation and operating instructions.

Markings and approvals

The following marks are available after positive testing of MAGNA3:

Mark	Description
	Intertek - ETL Listed for USA and Canada
	Conforms to ANSI/UL Std. 778 Motor Operated Water Pumps
	Certified to CAN/CSA C22.2 No. 108 Liquid Pumps
	USA and Canada Applies to pumps with stainless steel pump housing (flange).
NSF/ANSI 372	

10. Performance curves and technical data

Conversion tables

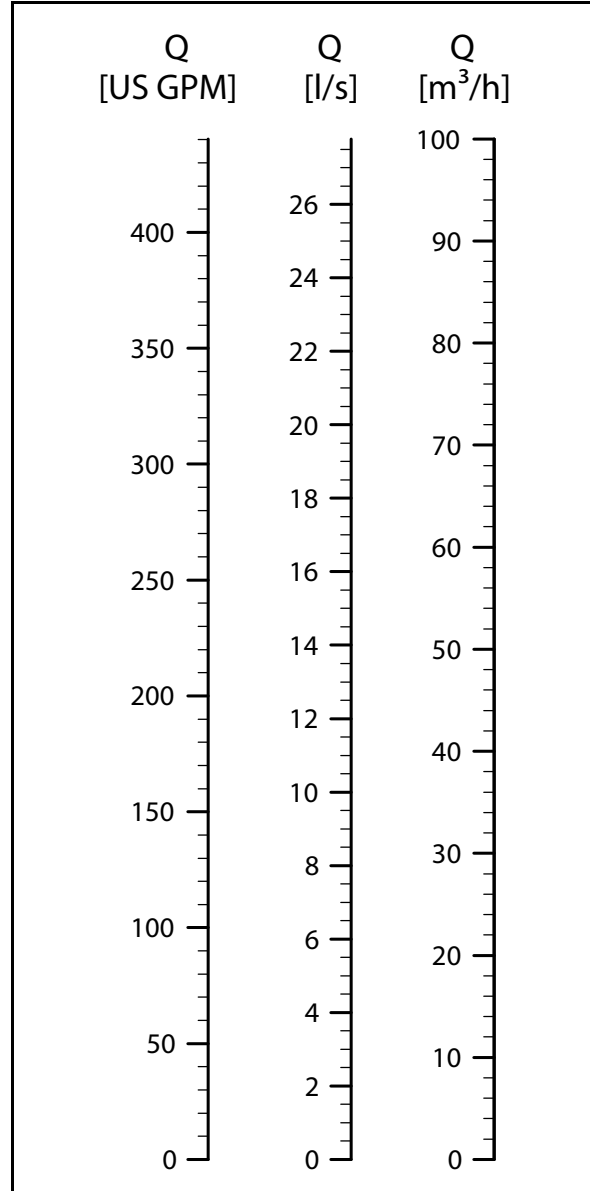
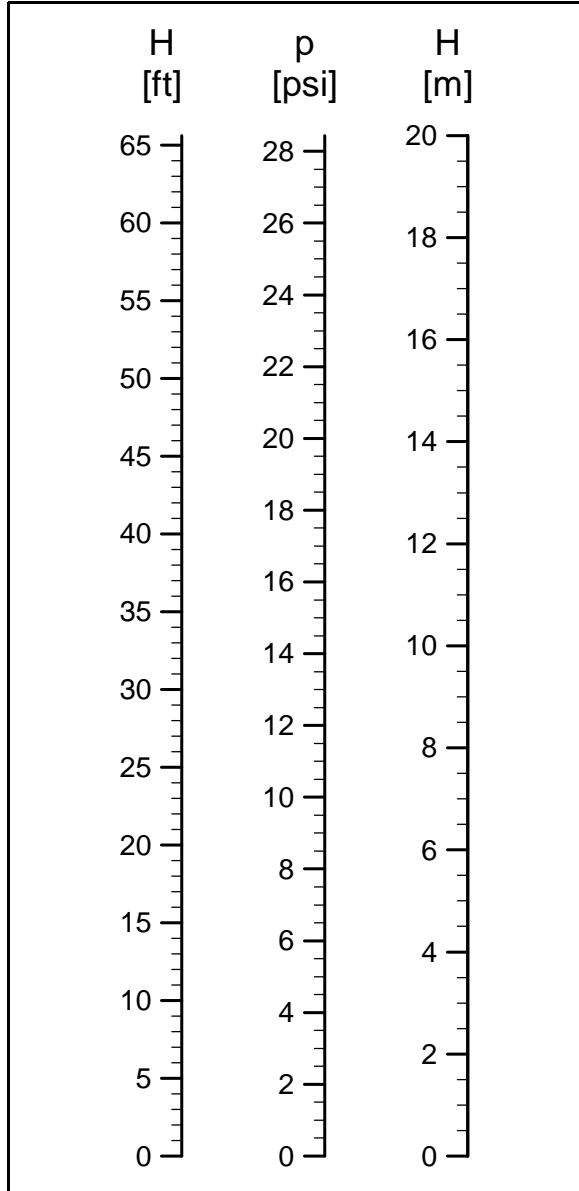

MAGNA3 32-60 F (N)

1 x 115, 230 V, 60 Hz

Proportional pressure

Constant pressure

0-10 volts*

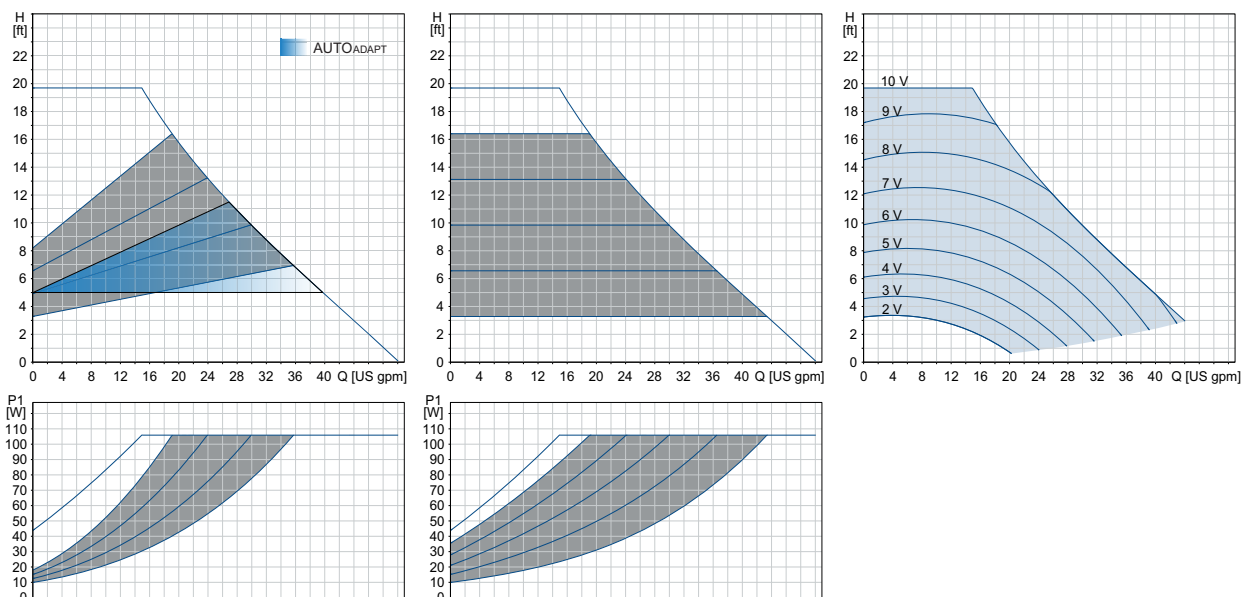

Speed	P1 [W] 115 V	I ₁ [A] 115 V	P1 [W] 230 V	I ₁ [A] 230 V
Min.	8.5	0.28	9	0.09
Max.	106	1.01	106	0.91

The pump incorporates overload protection.

Net weights [lb (kg)]	Shp. vol. [ft ³ (m ³)]
13.2 (6.0)	0.76 (0.03)

* External setpoint influence shown with a setpoint of H_{max}

- Connections: GF15/26/40/43 flanges. See [Pipe connections](#), page 67.
- System pressure: Max. 175 psi (1.2 MPa) (12 bar).
- Liquid temperature: 14 to 230 °F (-10 to +110 °C) (TF 110).
- Also available with: Stainless-steel pump housing, type N.
- Specific EEI: 0.20 (115 V), 0.19 (230 V)

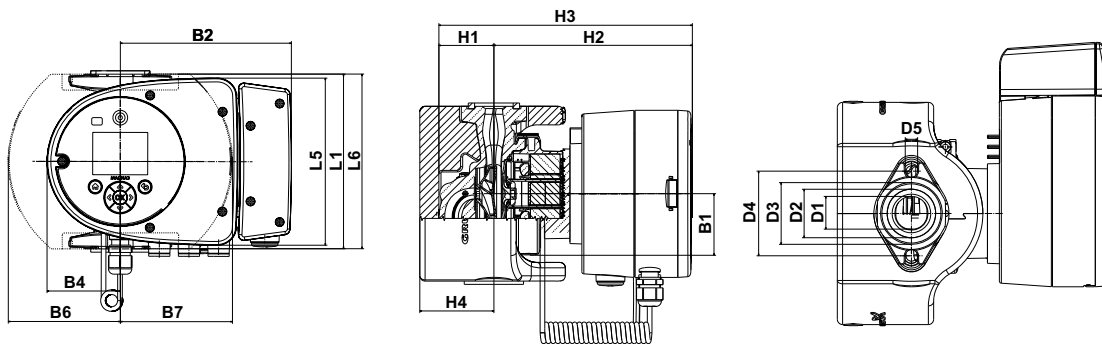

TM07 1509 1518

Pump type	Dimensions [inches (mm)]								
	L1	L5	L6	B1	B2	B4	B6	B7	D1
MAGNA3 32-60 F (N)	6.50 (165)	6.23 (158)	6.62 (168)	2.29 (58)	6.39 (162)	2.72 (69)	4.18 (106)	4.18 (106)	1.26 (32)
	D2	D3	D4	D5	H1	H2	H3	H4	
	1.82 (46)	2.29 (58)	3.15 (80)	0.46 (11.5)	2.13 (54)	7.37 (187)	9.49 (241)	2.76 (70)	

For product numbers, see page 68.

MAGNA3 32-100 F (N)

1 x 115, 230 V, 60 Hz

Proportional pressure

Constant pressure

0-10 volts*

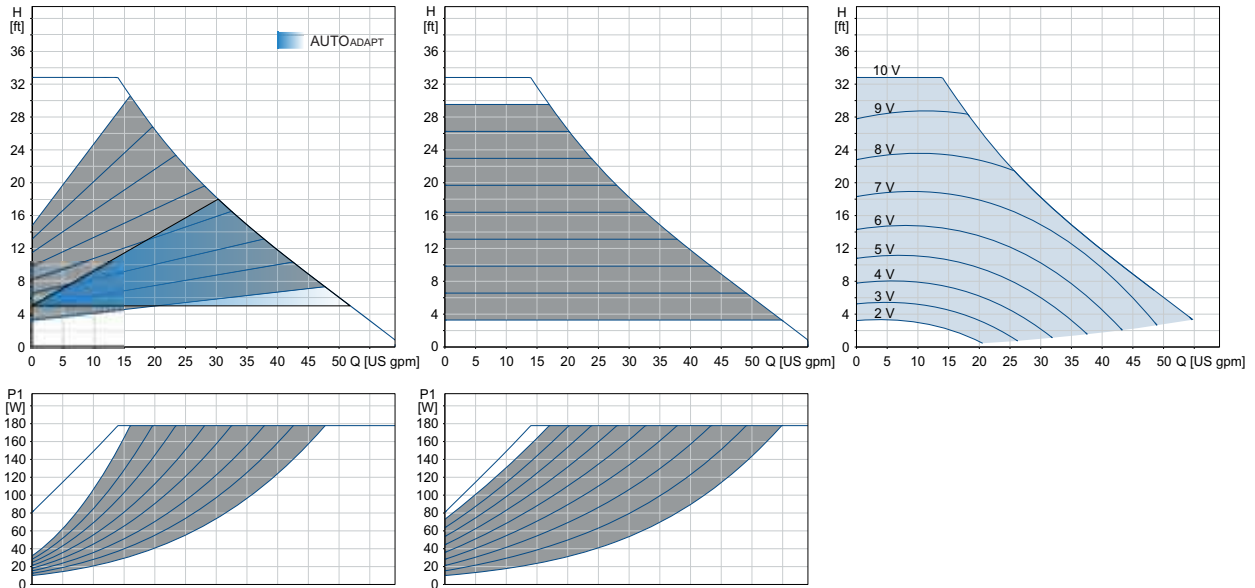

Speed	P1 [W] 115 V	I ₁ [A] 115 V	P1 [W] 230 V	I ₁ [A] 230 V
Min.	9.7	0.29	9	0.09
Max.	178	1.61	178	1.47

The pump incorporates overload protection.

Net weights [lb (kg)]	Shp. vol. [ft ³ (m ³)]
13.9 (6.3)	0.76 (0.03)

* External setpoint influence shown with a setpoint of H_{max}

- Connections: GF15/26/40/43 flanges. See [Pipe connections](#), page 67.
- System pressure: Max. 175 psi (1.2 MPa) (12 bar).
- Liquid temperature: 14 to 230 °F (-10 to +110 °C) (TF 110).
- Also available with: Stainless-steel pump housing, type N.
- Specific EEI: 0.20 (115 V), 0.19 (230 V)

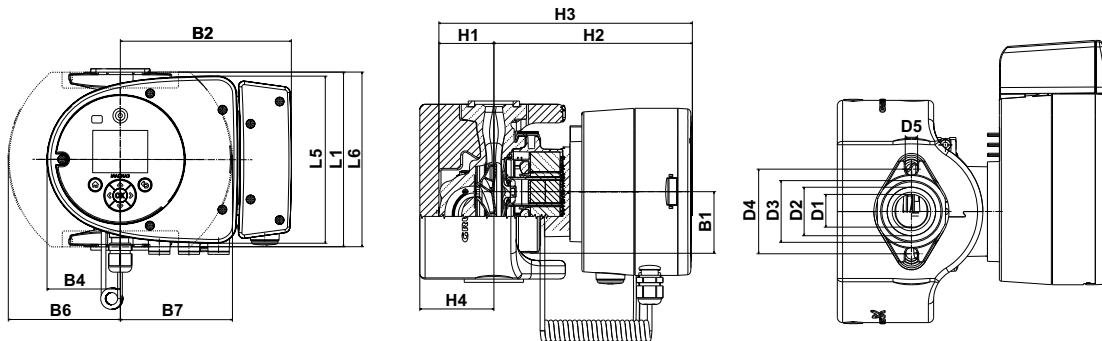

TM07 1509 1518

Pump type	Dimensions [inches (mm)]								
	L1	L5	L6	B1	B2	B4	B6	B7	D1
MAGNA3 32-100 F (N)	6.50 (165)	6.23 (158)	6.62 (168)	2.29 (58)	6.39 (162)	2.72 (69)	4.18 (106)	4.18 (106)	1.26 (32)
	D2	D3	D4	D5	H1	H2	H3	H4	
	1.82 (46)	2.29 (58)	3.15 (80)	0.46 (11.5)	2.13 (54)	7.37 (187)	9.49 (241)	2.76 (70)	

For product numbers, see page 68.

MAGNA3 32-120 F (N)

1 x 115, 230 V, 60 Hz

Proportional pressure

Constant pressure

0-10 volts*

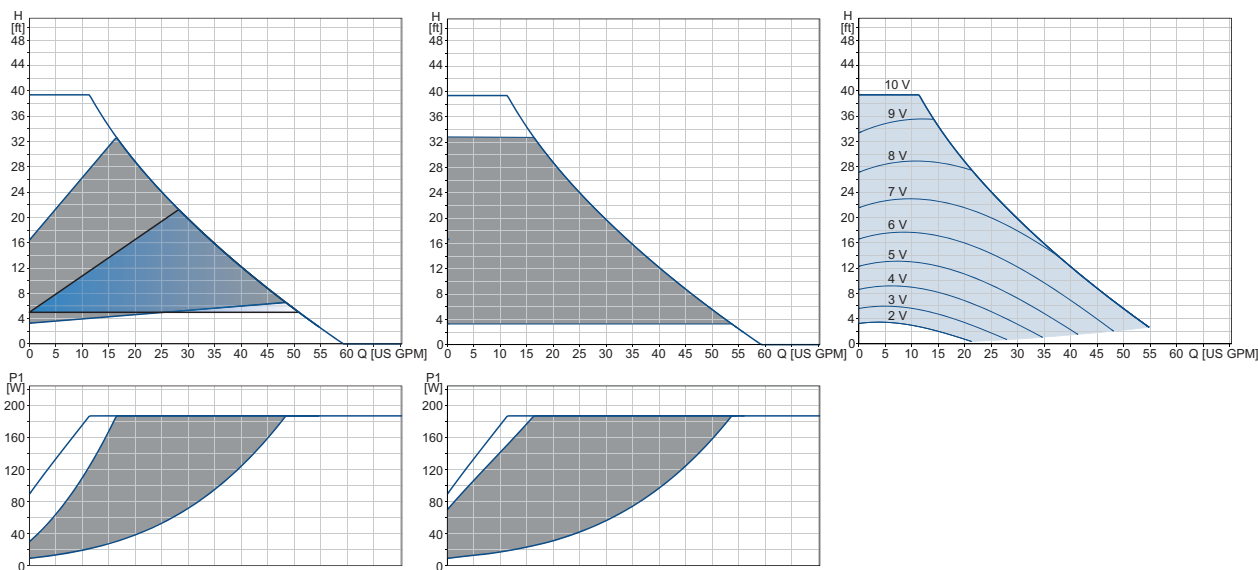

Speed	P1 [W] 115 V	I ₁ [A] 115 V	P1 [W] 230 V	I ₁ [A] 230 V
Min.	9.1	0.12	9.1	0.17
Max.	187	1.67	187	0.83

* External setpoint influence shown with a setpoint of H_{max}

The pump incorporates overload protection.

Net weights [lb (kg)]	Ship. vol. [ft ³ (m ³)]
13.2 (6.0)	0.70 (0.020)

- Connections: GF15/26/40/43 flanges. See [Pipe connections](#), page 67.
- System pressure: Max. 175 psi (1.2 MPa) (12 bar).
- Liquid temperature: 14 to 230 °F (-10 to +110 °C) (TF 110).
- Also available with: Stainless-steel pump housing, type N.
- Specific EEI: 0.20 (115 V)
0.20 (230 V)

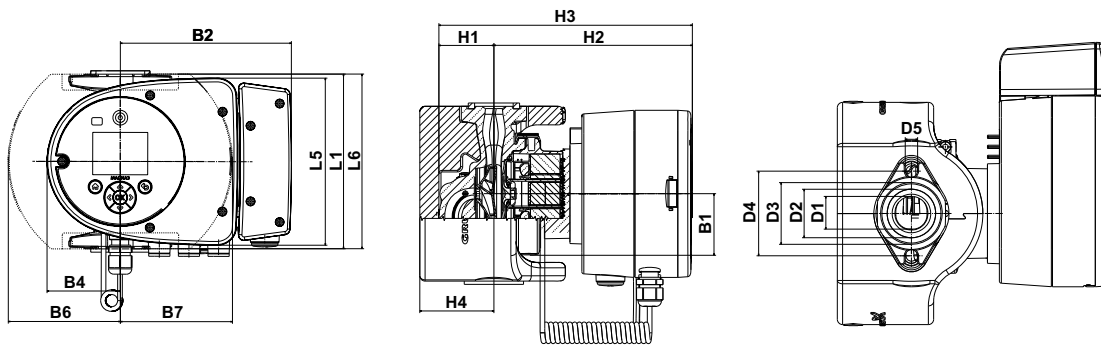

TM07 1509 1518

Pump type	Dimensions [inches (mm)]								
	L1	L5	L6	B1	B2	B4	B6	B7	D1
MAGNA3 32-120 F (N)	6.50 (165)	6.23 (158)	6.62 (168)	2.29 (58)	6.39 (162)	2.72 (69)	4.18 (106)	4.18 (106)	1.26 (32)
	D2	D3	D4	D5	H1	H2	H3	H4	
	1.82 (46)	2.29 (58)	3.15 (80)	0.46 (11.5)	2.13 (54)	7.37 (187)	9.49 (241)	2.76 (70)	

For product numbers, see page 68.

MAGNA3 40-80 F (N)

1 x 115, 230 V, 60 Hz

Proportional pressure

Constant pressure

0-10 volts*

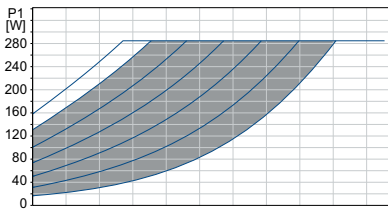
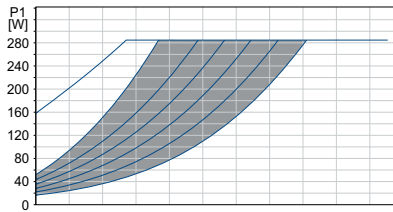
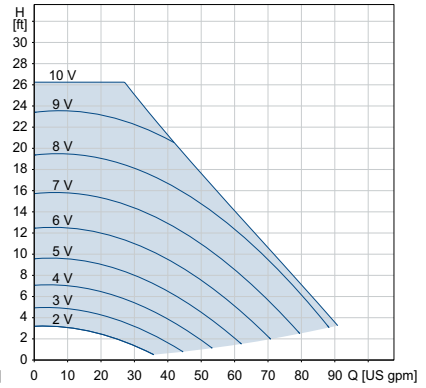
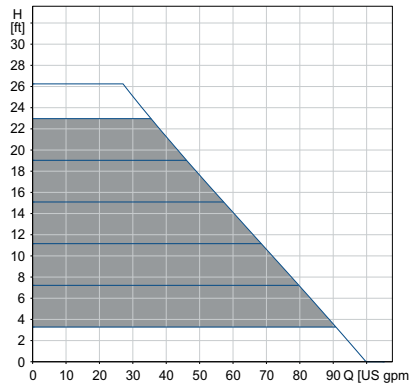
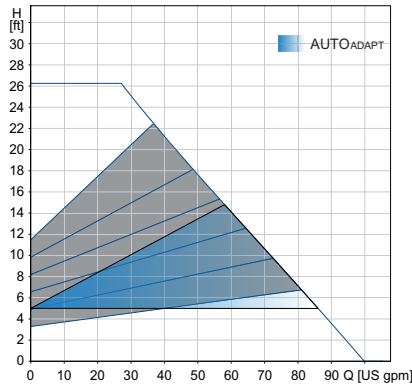

Speed	P1 [W] 115 V	I ₁ [A] 115 V	P1 [W] 230 V	I ₁ [A] 230 V
Min.	16	0.30	16	0.19
Max.	285	2.57	274	1.33

The pump incorporates overload protection.

Net weights [lb (kg)]	Shp. vol. [ft ³ (m ³)]
36.4 (16.5)	1.42 (0.04)

* External setpoint influence shown with a setpoint of H_{max}

- Connections: GF15/26/40/43 flanges. See [Pipe connections](#), page 67.
- System pressure: Max. 175 psi (1.2 MPa) (12 bar).
- Liquid temperature: 14 to 230 °F (-10 to +110 °C) (TF 110).
- Also available with: Stainless-steel pump housing, type N.
- Specific EEI: 0.20 (115 V)
0.19 (230 V)

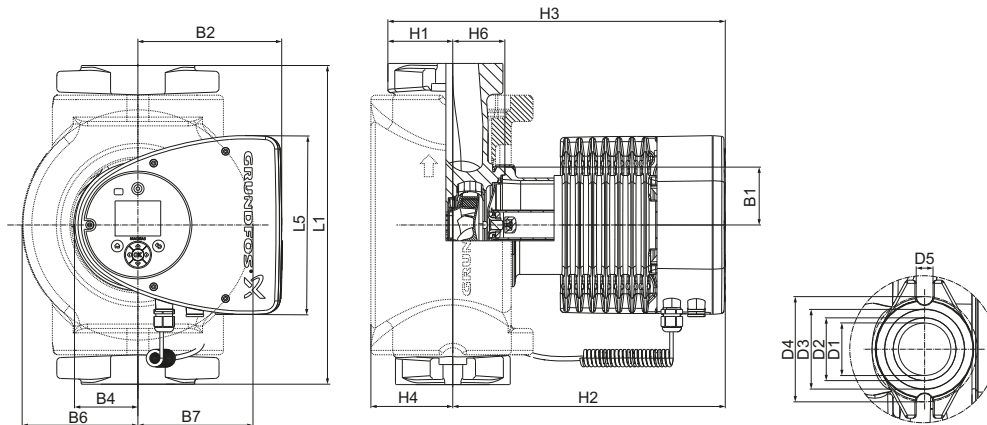

TM05 7651 2120

Pump type	Dimensions [in (mm)]								
	L1	L5	B1	B2	B4	B6	B7	D1	D2
MAGNA3 40-80 F (N)	8.5 (216)	8.03 (204)	3.31 (84)	6.46 (164)	2.87 (73)	4.37 (111)	4.37 (111)	1.57 (40)	1.93 (49)
	D3	D4	D5	H1	H2	H3	H4	H6	
	2.4 (60)	3.15 (80)	0.5 (12.8)	1.46 (37)	11.97 (304)	13.3 (338)	2.76 (70)	1.97 (50)	

For product numbers, see page 68.

MAGNA3 40-120 F (N)

1 x 115, 230 V, 60 Hz

Proportional pressure

Constant pressure

0-10 volts*

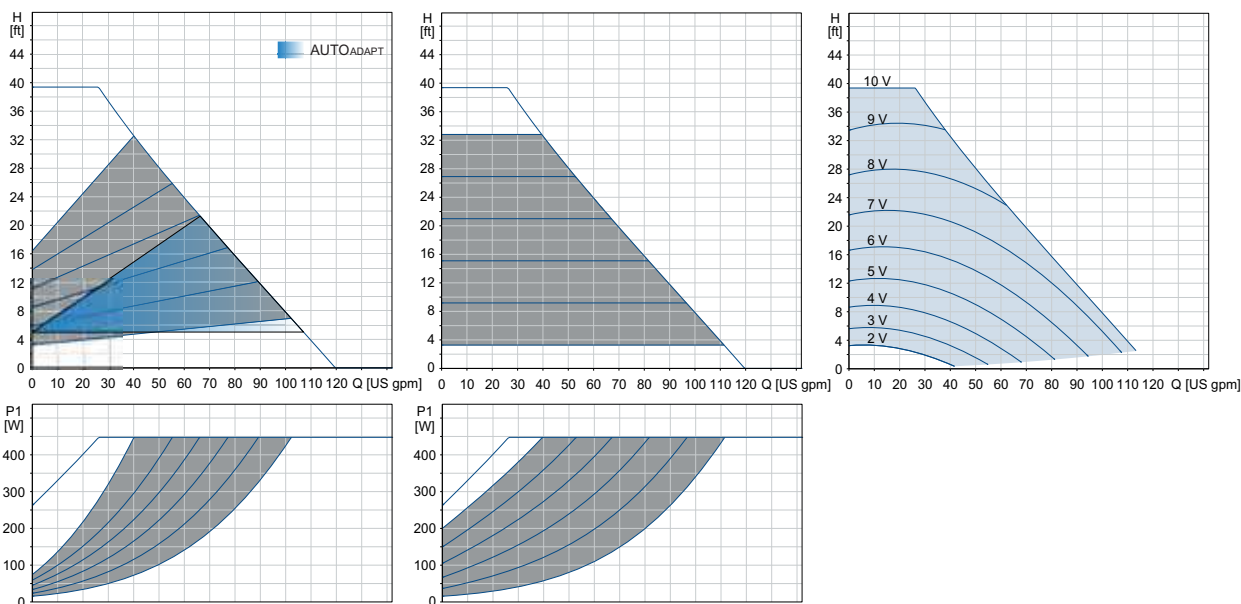

Speed	P1 [W] 115 V	I ₁ [A] 115 V	P1 [W] 230 V	I ₁ [A] 230 V
Min.	16	0.26	16	0.19
Max.	448	3.96	440	2.00

* External setpoint influence shown with a setpoint of H_{max}

The pump incorporates overload protection.

Net weights [lb (kg)]	Ship. vol. [ft ³ (m ³)]
35.8 (16.2)	1.42 (0.04)

Connections:

GF15/26/40/43 flanges.
See [Pipe connections](#), page 67.

System pressure:

Max. 175 psi (1.2 MPa) (12 bar).

Liquid temperature:

14 to 230 °F (-10 to +110 °C) (TF 110).

Also available with:

Stainless-steel pump housing, type N.

Specific EEI:

0.19 (115V)

0.19 (230V)

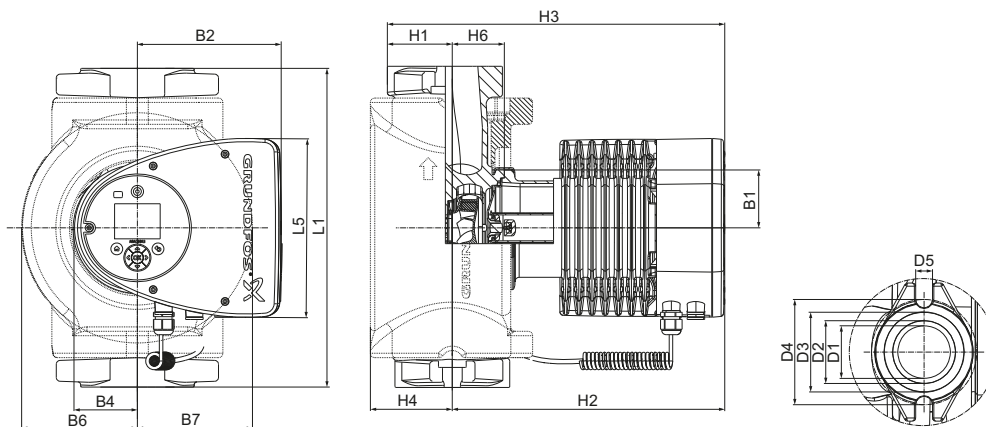

TM05 7651 2120

Pump type	Dimensions [in (mm)]								
	L1	L5	B1	B2	B4	B6	B7	D1	D2
MAGNA3 40-120 F (N)	8.5 (216)	8.03 (204)	3.31 (84)	6.46 (164)	2.87 (73)	4.37 (111)	4.37 (111)	1.57 (40)	1.93 (49)
	D3	D4	D5	H1	H2	H3	H4	H6	
	2.4 (60)	3.15 (80)	0.5 (12.8)	1.46 (37)	11.97 (304)	13.3 (338)	2.76 (70)	1.97 (50)	

For product numbers, see page 68.

MAGNA3 40-180 F (N)

1 x 115, 230 V, 60 Hz

Proportional pressure

Constant pressure

0-10 volts*

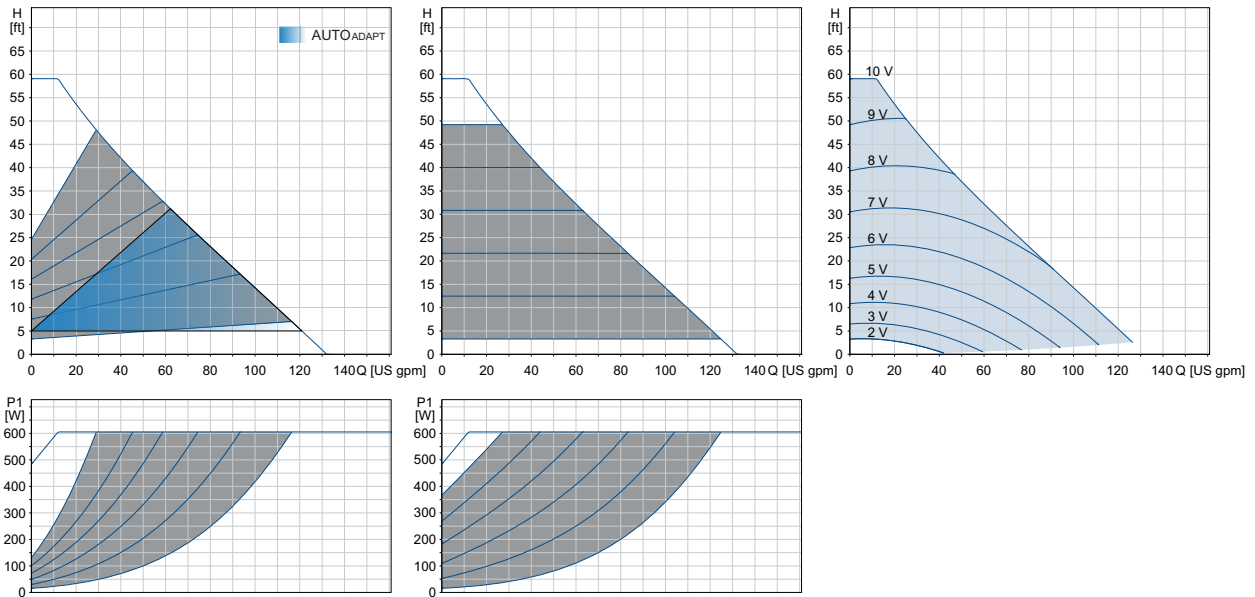

Speed	P1 [W] 115 V	I ₁ [A] 115 V	P1 [W] 230 V	I ₁ [A] 230 V
Min.	16	0.26	16	0.18
Max.	606	5.26	600	2.65

* External setpoint influence shown with a setpoint of H_{max}

The pump incorporates overload protection.

Net weights [lb (kg)]	Shp. vol. [ft ³ (m ³)]
35.8 (16.2)	1.42 (0.04)

Connections:

GF15/26/40/43 flanges.

See [Pipe connections](#), page 67.

System pressure:

Max. 175 psi (1.2 MPa) (12 bar).

Liquid temperature:

14 to 230 °F (-10 to +110 °C) (TF 110).

Also available with:

Stainless-steel pump housing, type N.

Specific EEI:

0.18 (115V)

0.19 (230V)

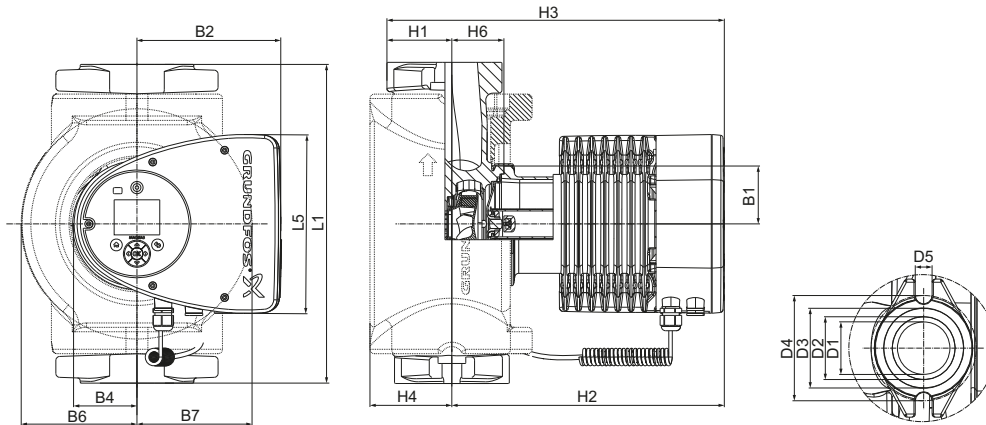

TM05 7651 2120

Pump type	Dimensions [in (mm)]								
	L1	L5	B1	B2	B4	B6	B7	D1	D2
MAGNA3 40-180 F (N)	8.5 (216)	8.03 (204)	3.31 (84)	6.46 (164)	2.87 (73)	4.37 (111)	4.37 (111)	1.57 (40)	1.93 (49)
	D3	D4	D5	H1	H2	H3	H4	H6	
	2.4 (60)	3.15 (80)	0.5 (12.8)	1.46 (37)	11.97 (304)	13.3 (338)	2.76 (70)	1.97 (50)	

For product numbers, see page 68.

MAGNA3 50-80 F (N)

1 x 115, 230 V, 60 Hz

Proportional pressure

Constant pressure

0-10 volts*

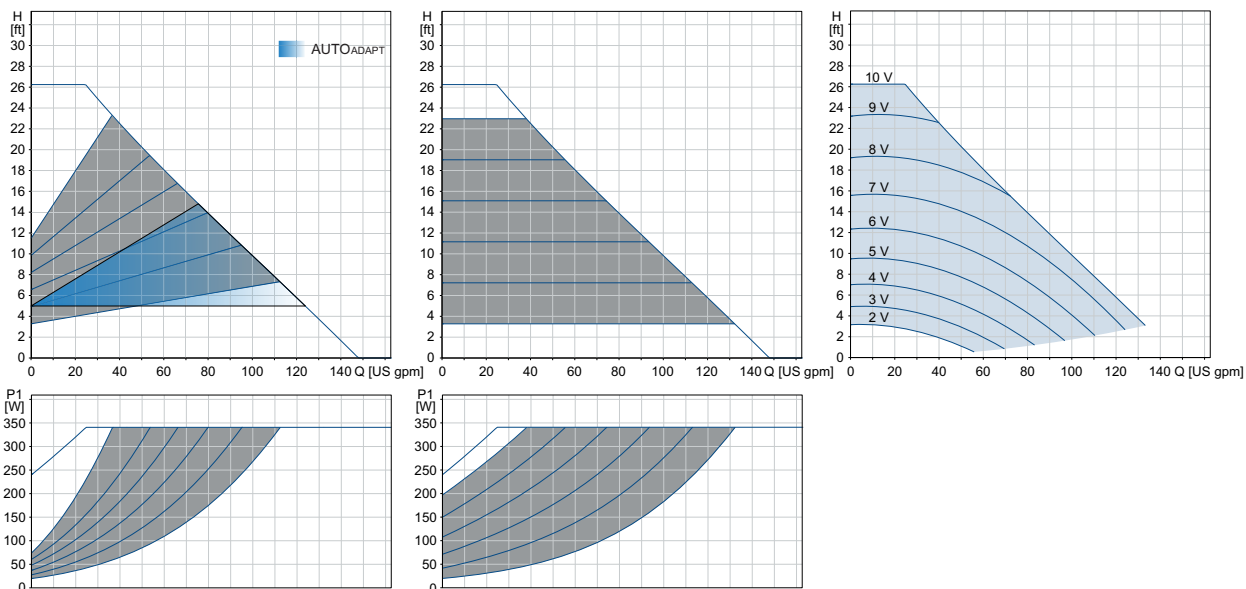

Speed	P1 [W]		I ₁ [A]	
	115 V	230 V	115 V	230 V
Min.	18.5	18.5	0.31	0.22
Max.	341	330	3.09	1.58

* External setpoint influence shown with a setpoint of H_{max}

The pump incorporates overload protection.

Net weights [lb (kg)]	Ship. vol. [ft ³ (m ³)]
39.3 (17.8)	1.77 (0.05)

Connections:

GF53 flanges.
See [Pipe connections](#), page 67.

System pressure: Max. 175 psi (1.2 MPa) (12 bar).
Liquid temperature: 14 to 230 °F (-10 to +110 °C) (TF 110).
Also available with: Stainless-steel pump housing, type N.
Specific EEI: 0.19 (115V) / 0.18 (230V)

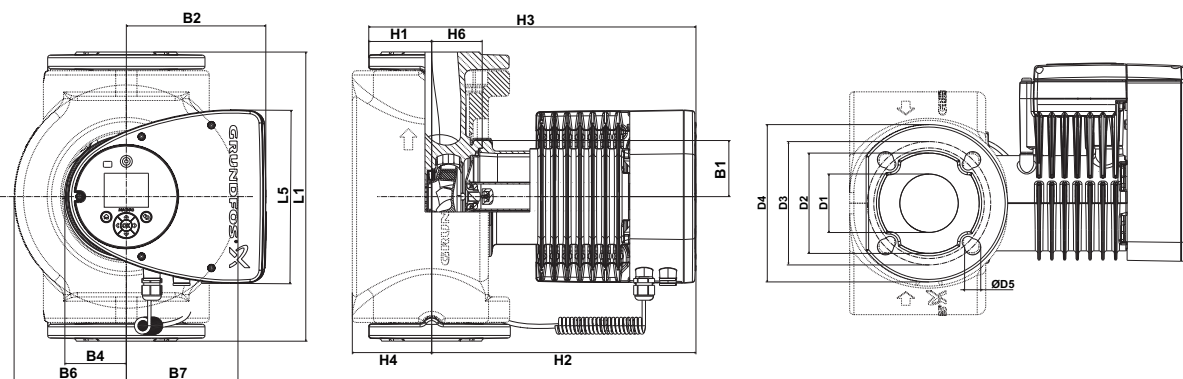

TM05 7652 1413

Pump type	Dimensions [in (mm)]									
	L1	L5	B1	B2	B4	B6	B7	D1	D2	
MAGNA3 50-80 F (N)	9.45 (240)	8.03 (204)	3.31 (84)	6.46 (164)	2.87 (73)	5 (127)	5 (127)	1.97 (50)	3.90 (99)	
	D3	D4	D5	H1	H2	H3	H4	H6		
	4.33/4.92 (110/125)	6.5 (165)	0.55/0.75 (14/19)	2.8 (71)	12.05 (306)	14.84 (377)	3.82 (97)	2.05 (52)		

For product numbers, see page 68.

MAGNA3 50-120 F (N)

1 x 115, 230 V, 60 Hz

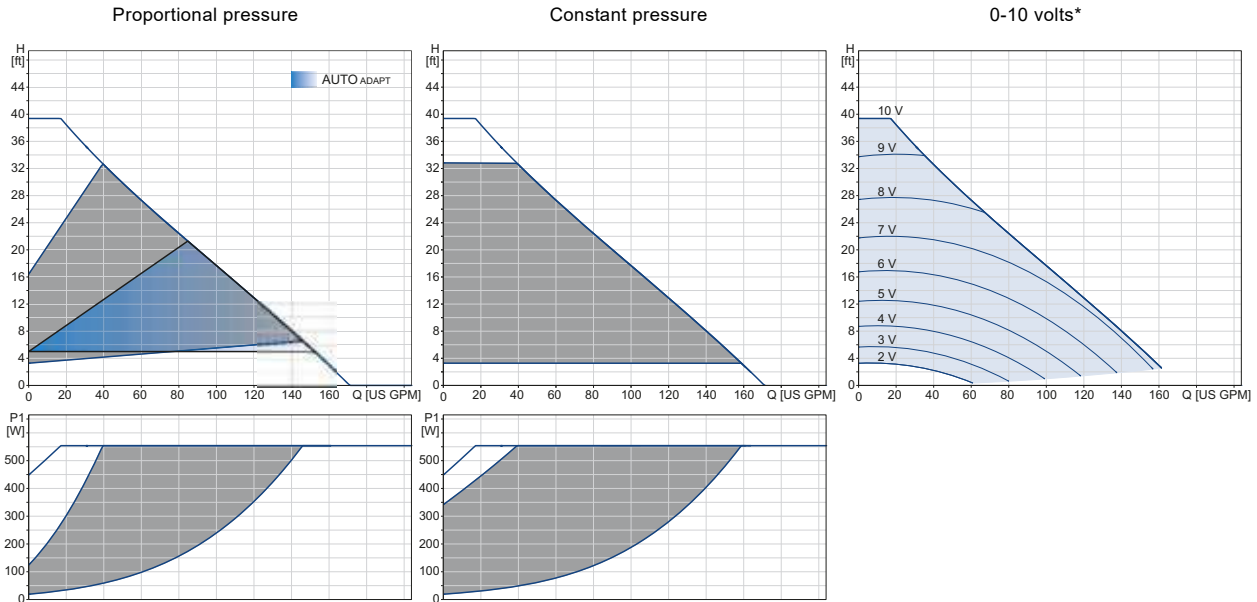

Speed	P1 [W] 115 V	I ₁ [A] 115 V	P1 [W] 230 V	I ₁ [A] 230 V
Min.	20.7	0.37	20.3	0.23
Max.	554	4.85	553	2.47

The pump incorporates overload protection.

Net weights [lb (kg)]	Ship. vol. [ft ³ (m ³)]
39.68 (18.0)	0.74 (0.021)

* External setpoint influence shown with a setpoint of H_{max}

- Connections: GF53 flanges. See [Pipe connections](#), page 67.
- System pressure: Max. 175 psi (1.2 MPa) (12 bar).
- Liquid temperature: 14 to 230 °F (-10 to +110 °C) (TF 110).
- Also available with: Stainless-steel pump housing, type N.
- Specific EEI: 0.19 (115V)
0.18 (230V)

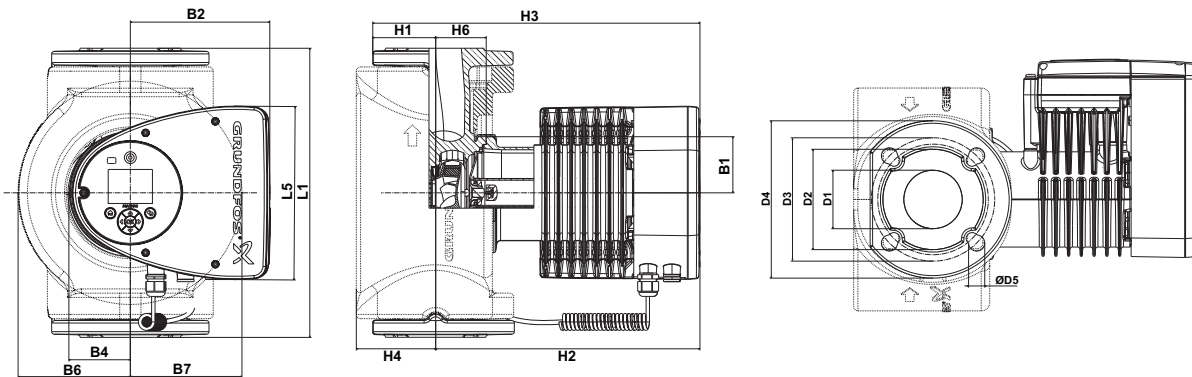

TM05 7652 14 13

Pump type	Dimensions [in (mm)]								
	L1	L5	B1	B2	B4	B6	B7	D1	D2
MAGNA3 50-120 F (N)	11.02 (280)	8.03 (204)	3.31 (84)	6.46 (164)	2.87 (73)	5 (127)	5 (127)	1.97 (50)	3.90 (99)
	D3	D4	D5	H1	H2	H3	H4	H6	
	4.33/4.92 (110/125)	6.5 (165)	0.55/0.75 (14/19)	2.83 (72)	12.05 (306)	14.9 (378)	3.82 (97)	2.05 (52)	

For product numbers, see page 68.

MAGNA3 50-150 F (N)

1 x 115, 230 V, 60 Hz

Proportional pressure

Constant pressure

0-10 volts*

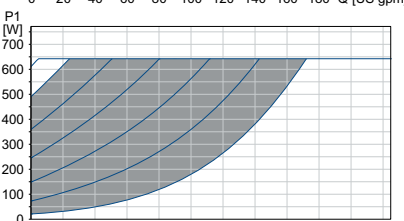
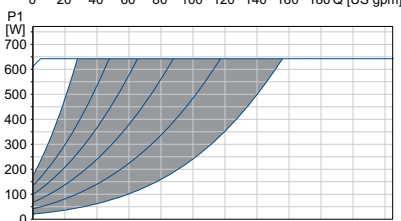
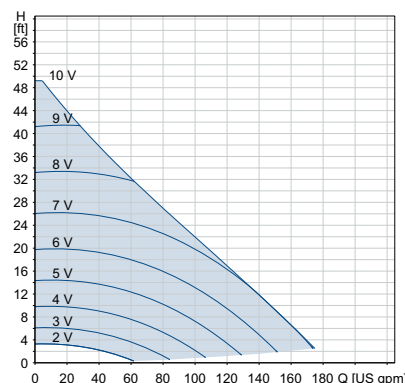
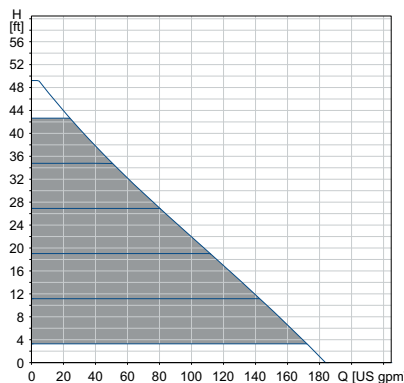
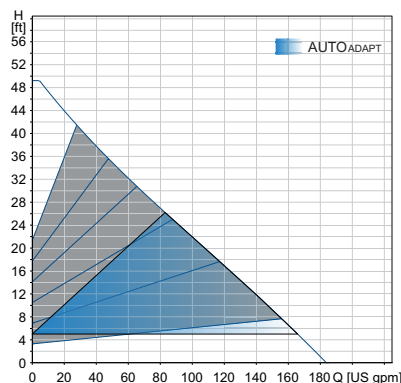

Speed	P1 [W] 115 V	I ₁ [A] 115 V	P1 [W] 230 V	I ₁ [A] 230 V
Min.	18.5	0.31	18.5	0.23
Max.	643	5.69	598	2.87

* External setpoint influence shown with a setpoint of H_{max}

The pump incorporates overload protection.

Net weights [lb (kg)]	Ship. vol. [ft ³ (m ³)]
42.2 (19.1)	1.77 (0.05)

Connections:

GF53 flanges.

See [Pipe connections](#), page 67.

System pressure:

Max. 175 psi (1.2 MPa) (12 bar).

Liquid temperature:

14 to 230 °F (-10 to +110 °C) (TF 110).

Also available with:

Stainless-steel pump housing, type N.

Specific EEI:

0.18 (115V)

0.17(230V)

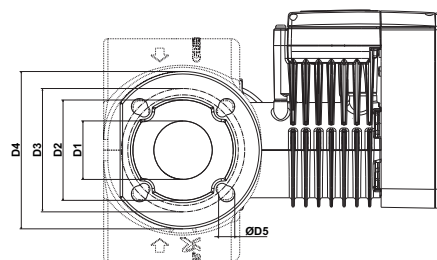
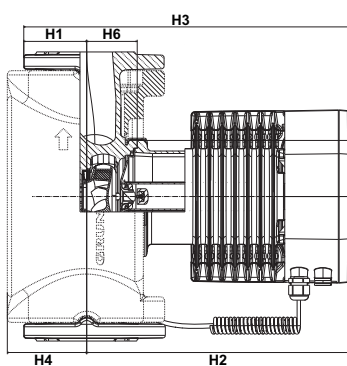
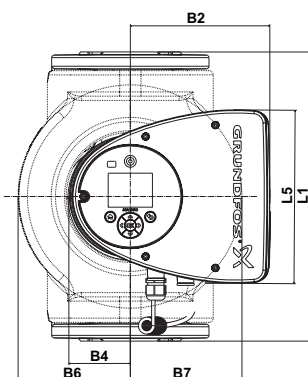

TM05 7652 1413

Pump type	Dimensions [in (mm)]									
	L1	L5	B1	B2	B4	B6	B7	D1	D2	
MAGNA3 50-150 F (N)	11.02 (280)	8.03 (204)	3.31 (84)	6.46 (164)	2.87 (73)	5 (127)	5 (127)	1.97 (50)	3.90 (99)	
	D3	D4	D5	H1	H2	H3	H4	H6		
	4.33/4.92 (110/125)	6.5 (165)	0.55/0.75 (14/19)	2.83 (72)	12.05 (306)	14.9 (378)	3.82 (97)	2.05 (52)		

For product numbers, see page 68.

MAGNA3 50-180 F (N)

1 x 115, 230 V, 60 Hz

Proportional pressure

Constant pressure

0-10 volts*

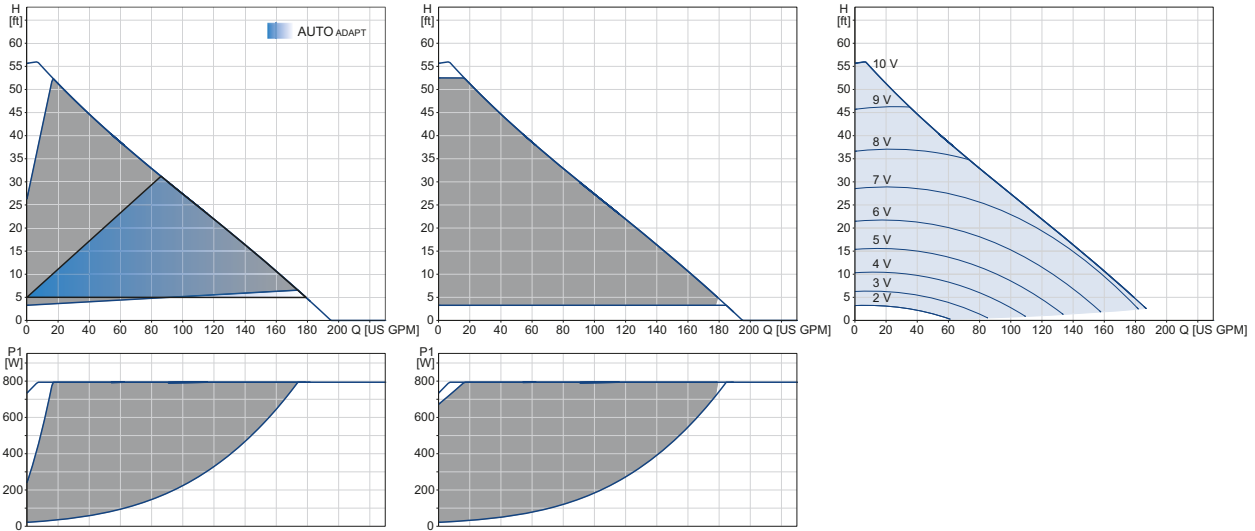

Speed	P1 [W] 115 V	I ₁ [A] 115 V	P1 [W] 230 V	I ₁ [A] 230 V
Min.	21.8	0.39	22.5	0.24
Max.	794	6.96	755	3.33

* External setpoint influence shown with a setpoint of H_{max}

The pump incorporates overload protection.

Net weights [lb (kg)]	Ship. vol. [ft ³ (m ³)]
44.1 (20)	1.77 (0.05)

Connections:

GF53 flanges.
See [Pipe connections](#), page 67.

System pressure: Max. 175 psi (1.2 MPa) (12 bar).

Liquid temperature: 14 to 230 °F (-10 to +110 °C) (TF 110).

Also available with: Stainless-steel pump housing, type N.

Specific EEI: 0.19 (115V)
0.18 (230V)

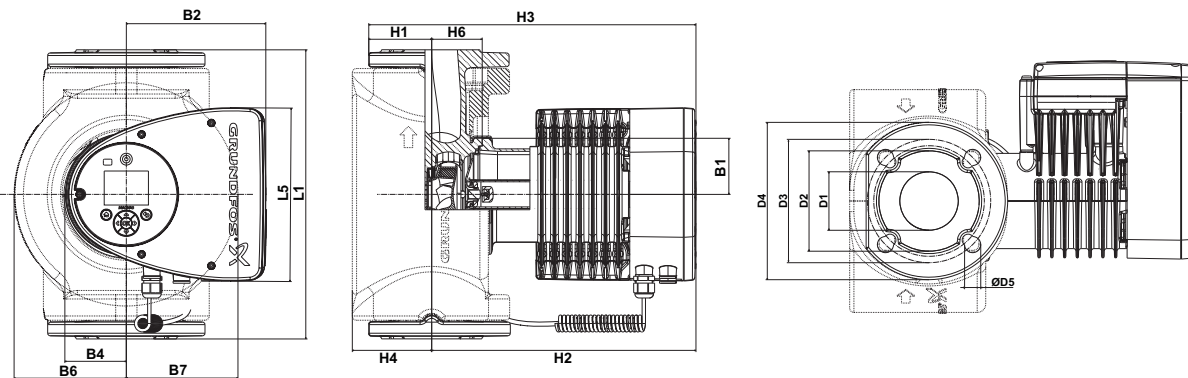

TM05 7652 1413

Pump type	Dimensions [in (mm)]									
	L1	L5	B1	B2	B4	B6	B7	D1	D2	
MAGNA3 50-180 F (N)	11.02 (280)	8.03 (204)	3.31 (84)	6.46 (164)	2.87 (73)	5 (127)	5 (127)	1.97 (50)	3.90 (99)	
	D3	D4	D5	H1	H2	H3	H4	H6		
	4.33/4.92 (110/125)	6.5 (165)	0.55/0.75 (14/19)	2.83 (72)	12.05 (306)	14.9 (378)	3.82 (97)	2.05 (52)		

For product numbers, see page 68.

MAGNA3 65-120 F (N)

1 x 115, 230 V, 60 Hz

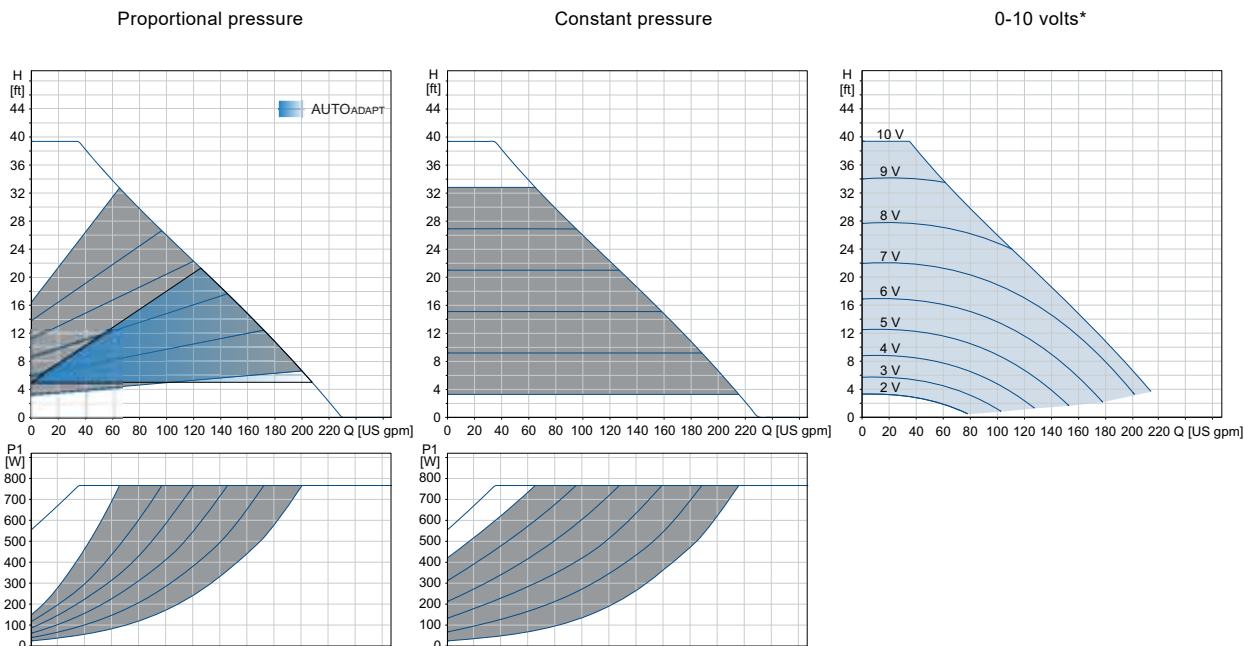

Speed	P1 [W] 115 V	I ₁ [A] 115 V	P1 [W] 230 V	I ₁ [A] 230 V
Min.	20.5	0.36	0.18	20.5
Max.	767	6.75	758	3.32

The pump incorporates overload protection.

Net weights [lb (kg)]	Ship. vol. [ft ³ (m ³)]
47.4 (21.5)	2.12 (0.06)

* External setpoint influence shown with a setpoint of H_{max}

Connections: GF53/65 flanges. See [Pipe connections](#), page 67.
 System pressure: Max. 175 psi (1.2 MPa) (12 bar).
 Liquid temperature: 14 to 230 °F (-10 to +110 °C) (TF 110).
 Also available with: Stainless-steel pump housing, type N.
 Specific EEI: 0.17 (115V) / 0.17 (230V)

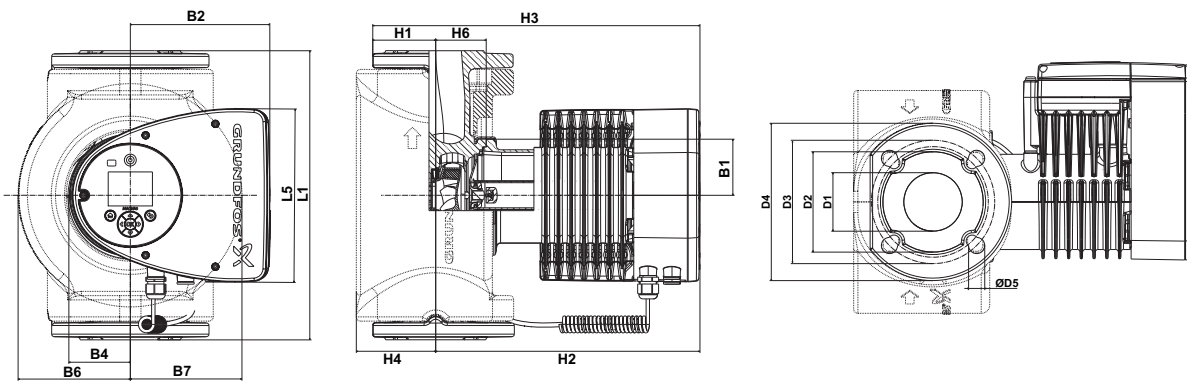

TMO5 7652 1413

Pump type	Dimensions [in (mm)]									
	L1	L5	B1	B2	B4	B6	B7	D1	D2	
MAGNA3 65-120 F (N)	13.4 (340)	8.03 (204)	3.31 (84)	6.46 (164)	2.87 (73)	5.24 (133)	5.24 (133)	2.56 (65)	4.65 (118)	
	D3	D4	D5	H1	H2	H3	H4	H6		
	5.0/5.51 (127/140)	7.28 (185)	0.63/0.75 (16/19)	2.91 (74)	12.28 (312)	15.2 (386)	3.7 (94)	2.32 (59)		

For product numbers, see page 68.

MAGNA3 65-150 F (N)

1 x 230 V, 60 Hz

Proportional pressure

Constant pressure

0-10 volts*

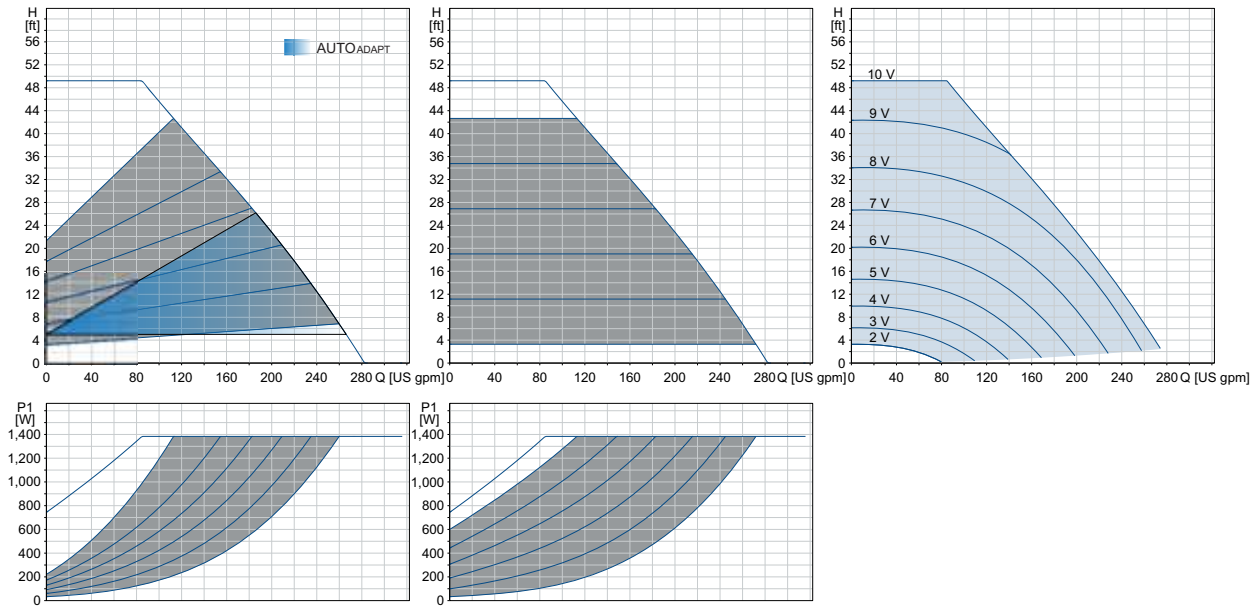

Speed	P1 [W] 230 V	I ₁ [A] 230 V
Min.	31	0.32
Max.	1385	6.10

The pump incorporates overload protection.

Net weights [lb (kg)]	Ship. vol. [ft ³ (m ³)]
66.2 (30.0)	2.12 (0.06)

* External setpoint influence shown with a setpoint of H_{max}

Connections:

GF53/65 flanges.
See [Pipe connections](#), page 67.

System pressure: Max. 175 psi (1.2 MPa) (12 bar).
Liquid temperature: 14 to 230 °F (-10 to +110 °C) (TF 110).
Also available with: Stainless-steel pump housing, type N.
Specific EEI: 0.17.

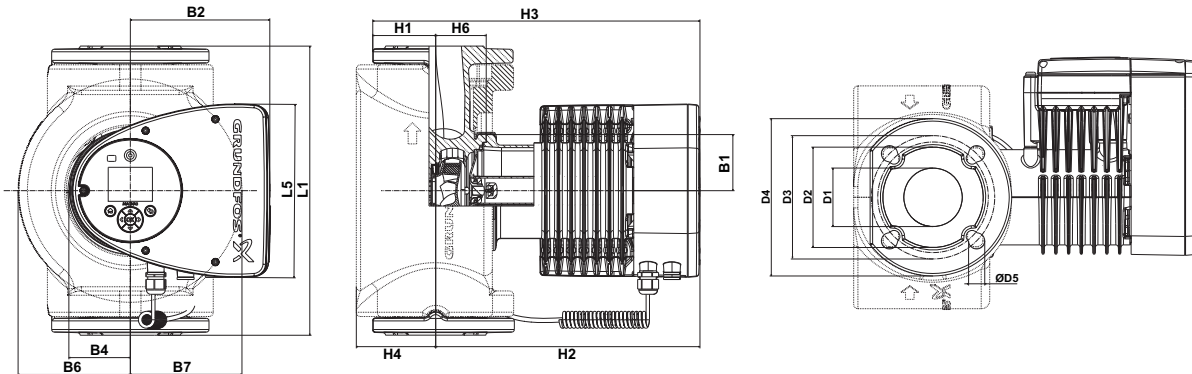

TM05 7652 1413

Pump type	Dimensions [in (mm)]									
	L1	L5	B1	B2	B4	B6	B7	D1	D2	
MAGNA3 65-150 F (N)	13.4 (340)	8.03 (204)	3.31 (84)	6.46 (164)	2.87 (73)	5.24 (133)	5.24 (133)	2.56 (65)	4.65 (118)	
	D3	D4	D5	H1	H2	H3	H4	H6		
	5.0/5.51 (127/140)	7.28 (185)	0.63/0.75 (16/19)	2.91 (74)	12.28 (312)	15.2 (386)	3.7 (94)	2.32 (59)		

For product numbers, see page 68.

MAGNA3 D 65-150 F

1 x 230 V, 60 Hz

Proportional pressure

Constant pressure

0-10 volt*

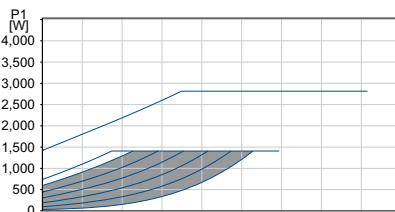
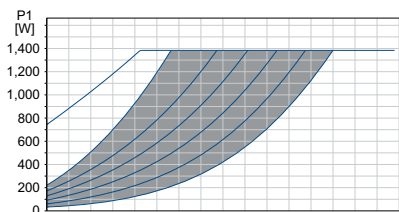
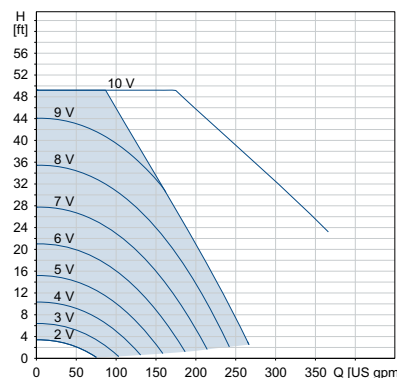
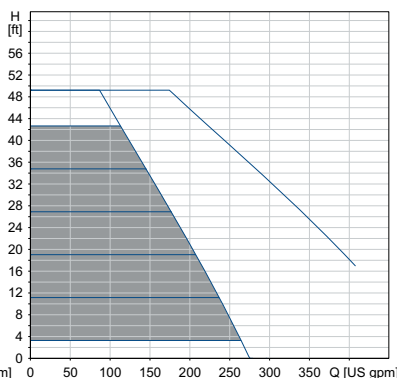
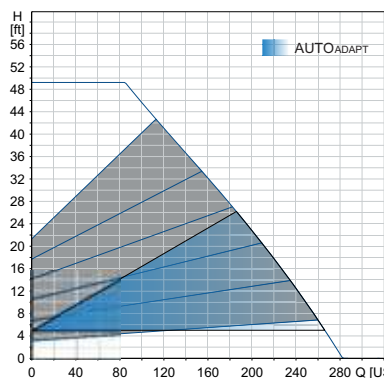

Speed	P1 [W] 230 V	I ₁ [A] 230 V
Min.	29	0.30
Max.	1409	6.18

The pump incorporates overload protection.

Net weights [lb (kg)]	Ship. vol. [ft ³ (m ³)]
101 (45.8)	2.12 (0.06)

* External setpoint influence shown with a setpoint of H_{max}

Connections: GF53/65 flanges.
See [Pipe connections](#), page 67.
System pressure: Max. 175 psi (1.2 MPa) (12 bar).
Liquid temperature: 14 to 230 °F (-10 to +110 °C) (TF 110).
Specific EEI: 0.17.

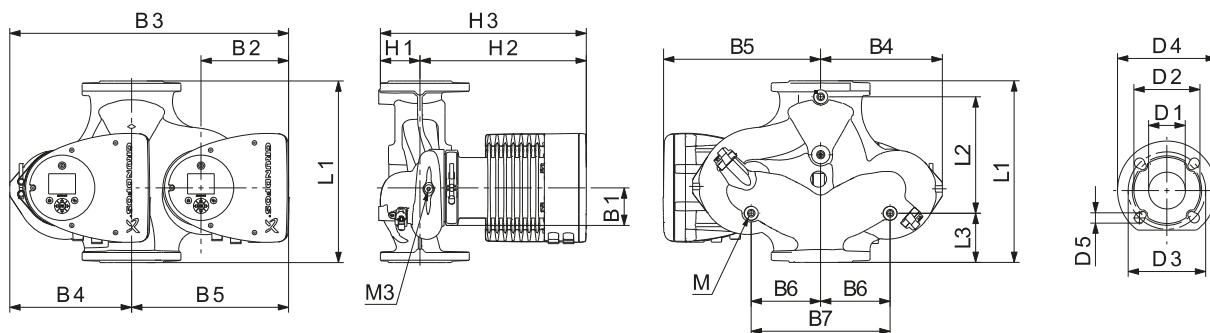

TM05 2205 2214

Pump type	Dimensions [in (mm)]								
	L1	L2	L3	L4	L5	B1	B3	B4	B5
MAGNA3 D 65-150 F	13.4 (340)	8.58 (218)	3.62 (92)	3.62 (92)	8.03 (204)	3.31 (84)	20.55 (522)	8.98 (228)	11.57 (294)
	D1	D2	D3	D4	D5	D5 (2)	M	M1	H1
	2.56 (65)	4.69 (119)	5.12/5.71 (130/145)	7.28 (185)	0.55 (14)	0.75 (19)	M12	Rp 1/4	3.03 (77)

For product numbers, see page 68.

MAGNA3 80-100 F (N)

1 x 230 V, 60 Hz

Proportional pressure

Constant pressure

0-10 volts*

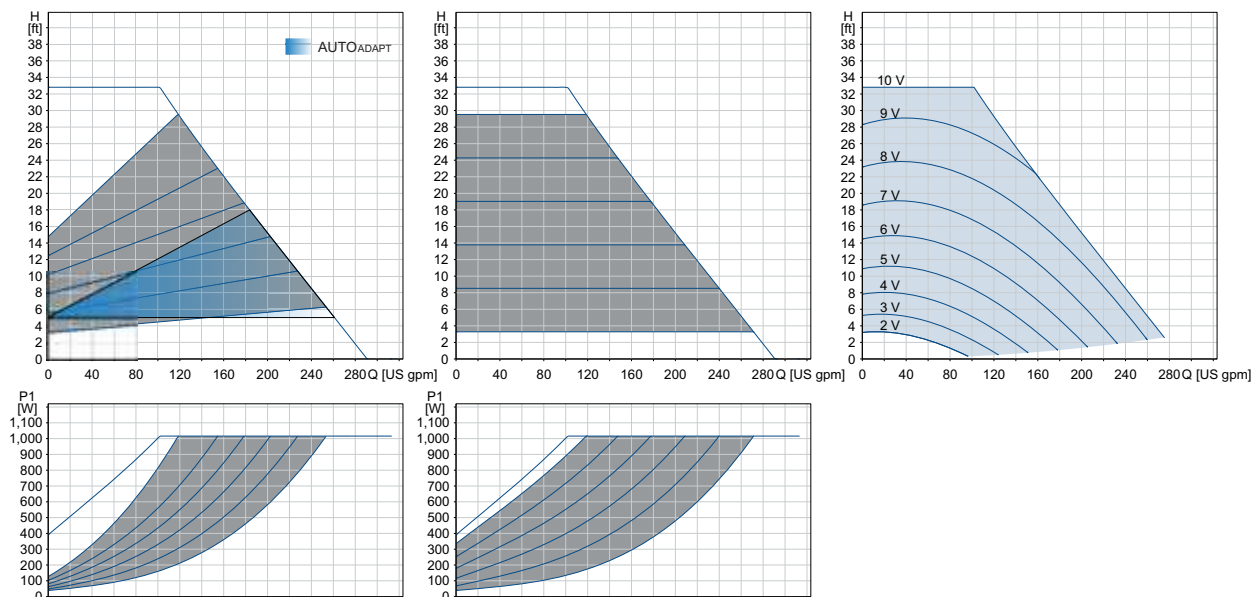

Speed	P1 [W] 230 V	I ₁ [A] 230 V
Min.	31	0.32
Max.	1017	4.51

The pump incorporates overload protection.

Net weights [lb (kg)]	Shp. vol. [ft ³ (m ³)]
66.2 (30.0)	2.47 (0.07)

* External setpoint influence shown with a setpoint of H_{max}

Connections:

GF80 flanges.
See [Pipe connections](#), page 67.

System pressure:

Max. 175 psi (1.2 MPa) (12 bar).

Liquid temperature:

14 to 230 °F (-10 to +110 °C) (TF 110).

Specific EEI:

0.17.

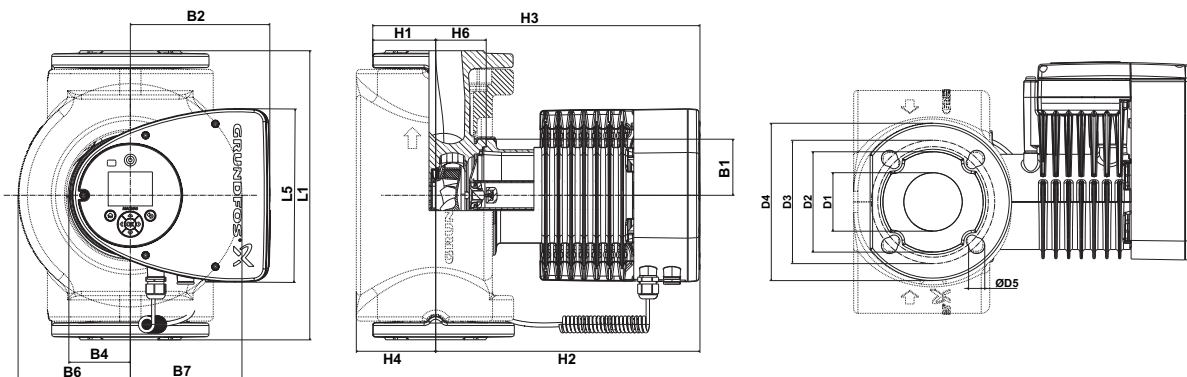

TM05 7652 1413

Pump type	Dimensions [in (mm)]								
	L1	L5	B1	B2	B4	B6	B7	D1	D2
MAGNA3 80-100 F (N)	14.17 (360)	8.03 (204)	3.31 (84)	6.46 (164)	2.87 (73)	6.42 (163)	6.42 (163)	3.15 (80)	5.2 (132)
	D3	D4	D5	H1	H2	H3	H4	H6	
	5.91 (150)	7.87 (200)	0.75 (19)	3.7 (94)	12.52 (318)	16.22 (412)	4.53 (115)	2.6 (66)	

For product numbers, see page 68.

MAGNA3 D 80-100 F

1 x 230 V, 60 Hz

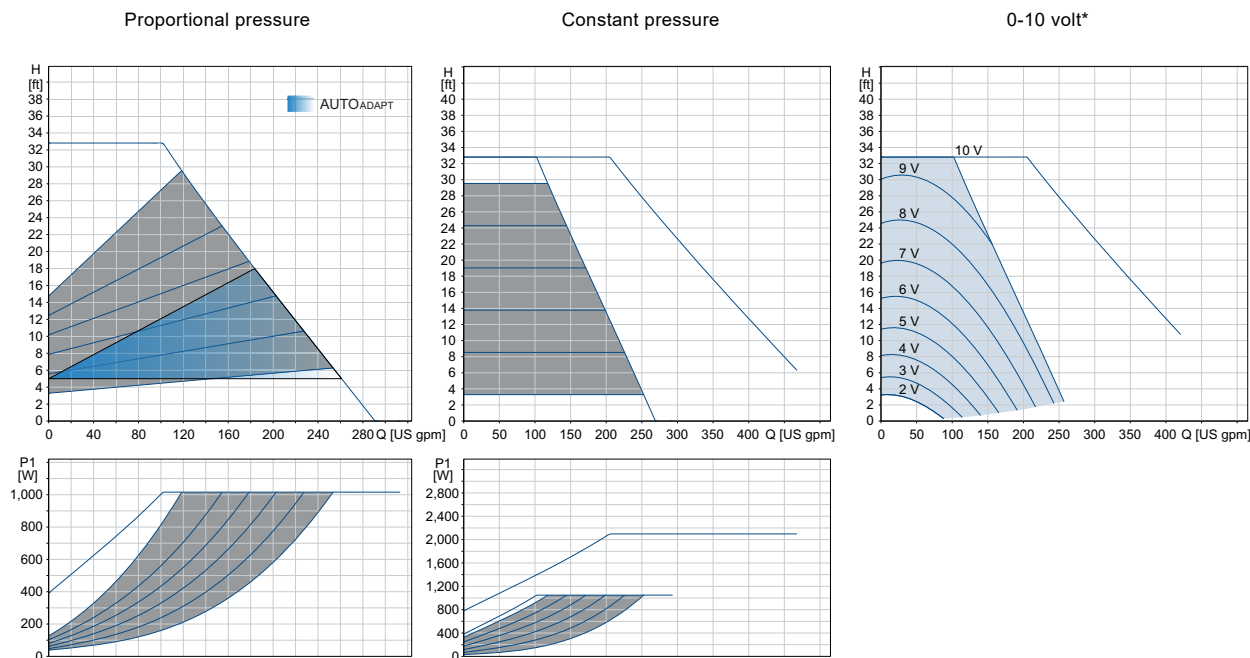

Speed	P1 [W] 230 V	I ₁ [A] 230 V
Min.	32	0.32
Max.	1050	4.71

The pump incorporates overload protection.

Net weights [lb (kg)]	Ship. vol. [ft ³ (m ³)]
116.9 (53.0)	7.5 (0.208)

* External setpoint influence shown with a setpoint of H_{max}

Connections: GF80 flanges. See [Pipe connections](#), page 6Z.
 System pressure: Max. 175 psi (1.2 MPa) (12 bar).
 Liquid temperature: 14 to 230 °F (-10 to +110 °C) (TF 110).
 Specific EEI: 0.17.

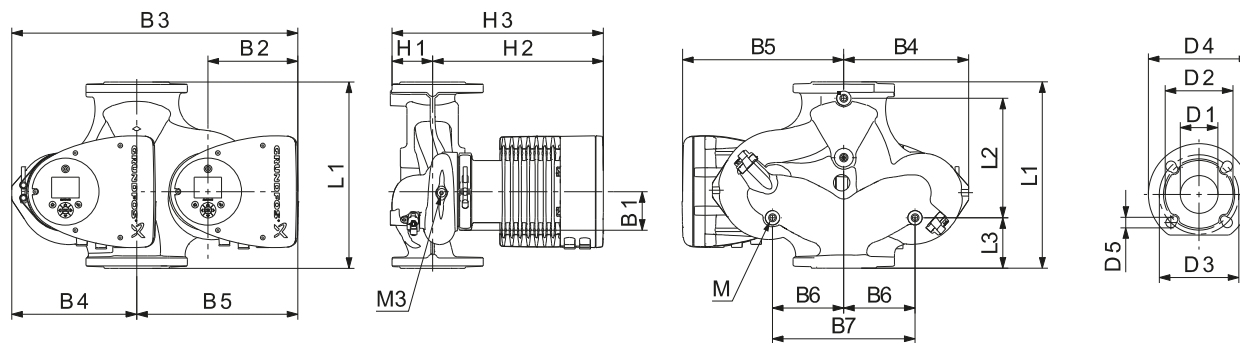

TM05 2205 2214

Pump type	Dimensions [in (mm)]								
	L1	L2	L3	L4	L5	B1	B3	B4	B5
MAGNA3 D 80-100 F	14.17 (360)	8.58 (218)	4.02 (102)	4.02 (102)	8.03 (204)	3.31 (84)	21.18 (538)	9.61 (244)	11.57 (294)
	D1	D2	D3	D3 (2)	D4	D5	M	M1	H1
	3.15 (80)	5.04 (128)	5.91 (150)	6.30 (160)	7.87 (200)	0.75 (19)	M12	Rp 1/4	3.82 (97)

For product numbers, see page 68.

MAGNA3 100-120 F (N)

1 x 230 V, 60 Hz

Proportional pressure

Constant pressure

0-10 volts*

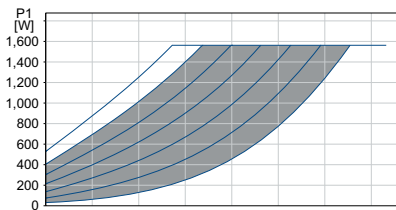
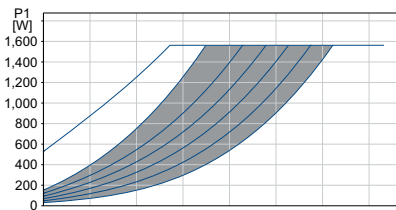
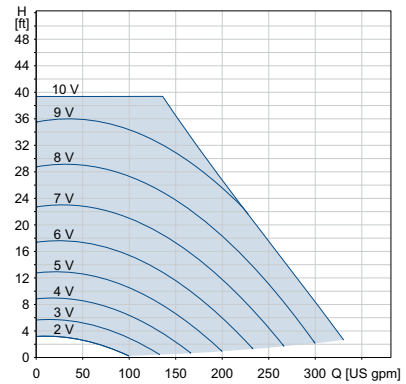
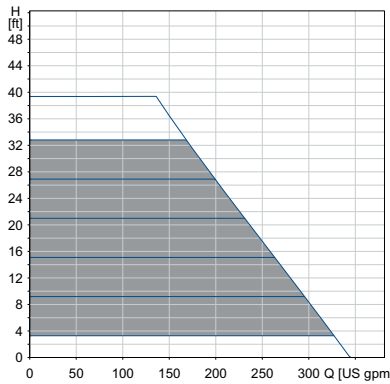
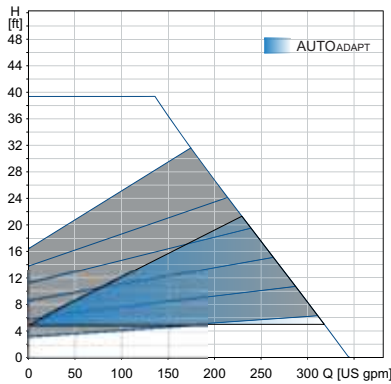

Speed	P1 [W] 230 V	I ₁ [A] 230 V
Min.	31	0.32
Max.	1564	6.78

* External setpoint influence shown with a setpoint of H_{max}

The pump incorporates overload protection.

Net weights [lb (kg)]	Shp. vol. [ft ³ (m ³)]
76.8 (34.8)	3.53 (0.1)

Connections: GF100 flanges. See [Pipe connections](#), page 67.
 System pressure: Max. 175 psi (1.2 MPa) (12 bar).
 Liquid temperature: 14 to 230 °F (-10 to +110 °C) (TF 110).
 Specific EEI: 0.17.

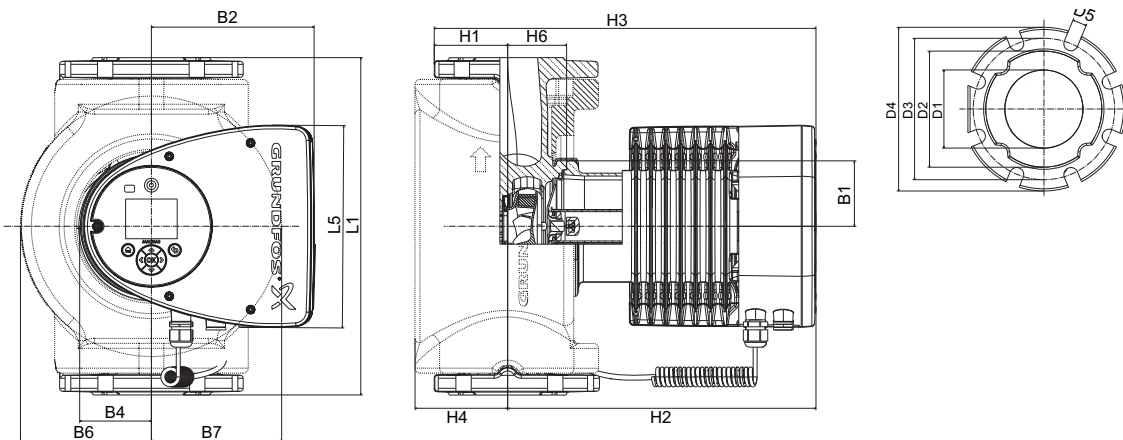

TM05 7650 2120

Pump type	Dimensions [in (mm)]								
	L1	L5	B1	B2	B4	B6	B7	D1	D2
MAGNA3 100-120 F (N)	17.72 (450)	8.03 (204)	3.31 (84)	6.46 (164)	2.87 (73)	7.01 (178)	7.01 (178)	3.94 (100)	6.14 (156)
	D3	D4	D5	H1	H2	H3	H4	H6	
	7.52 (191)	8.66 (220)	0.75 (19)	4.02 (102)	12.99 (330)	17.01 (432)	4.72 (120)	3.11 (79)	

For product numbers, see page 68.

MAGNA3 D 100-120 F

1 x 230 V, 60 Hz

Proportional pressure

Constant pressure

0-10 volts*

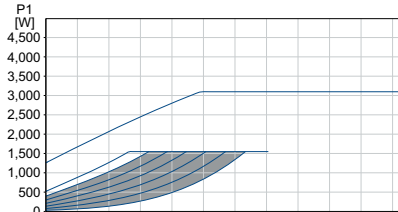
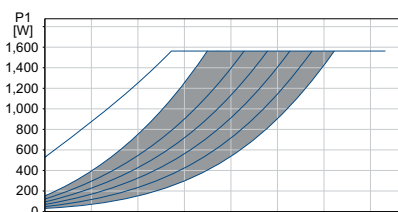
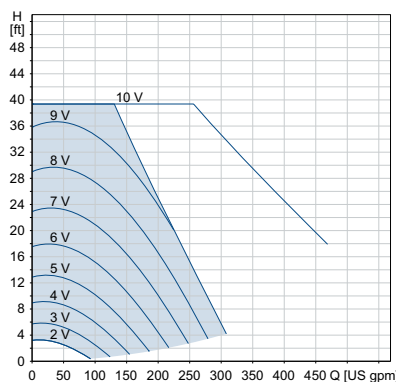
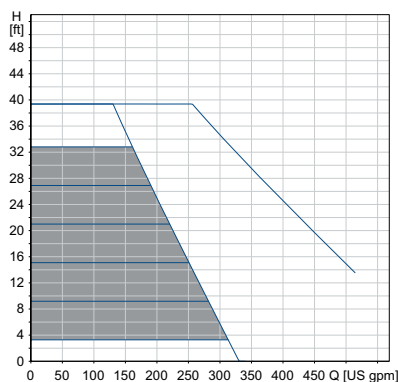
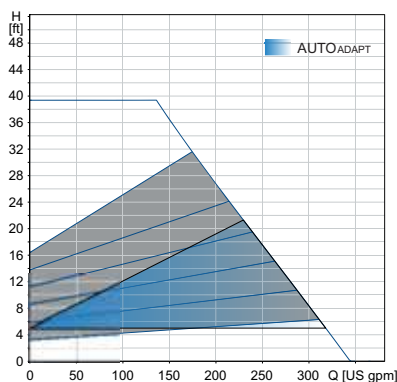

Speed	P1 [W] 230 V	I ₁ [A] 230 V
Min.	35	0.35
Max.	1550	6.78

The pump incorporates overload protection.

Net weights [lb (kg)]	Shp. vol. [ft ³ (m ³)]
138.3 (62.7)	7.4 (0.208)

* External setpoint influence shown with a setpoint of H_{max}

Connections: GF100 flanges. See [Pipe connections](#), page 67.
 System pressure: Max. 175 psi (1.2 MPa) (12 bar).
 Liquid temperature: -14 to 230 °F (10 to +110 °C) (TF 110).
 Specific EEI: 0.17.

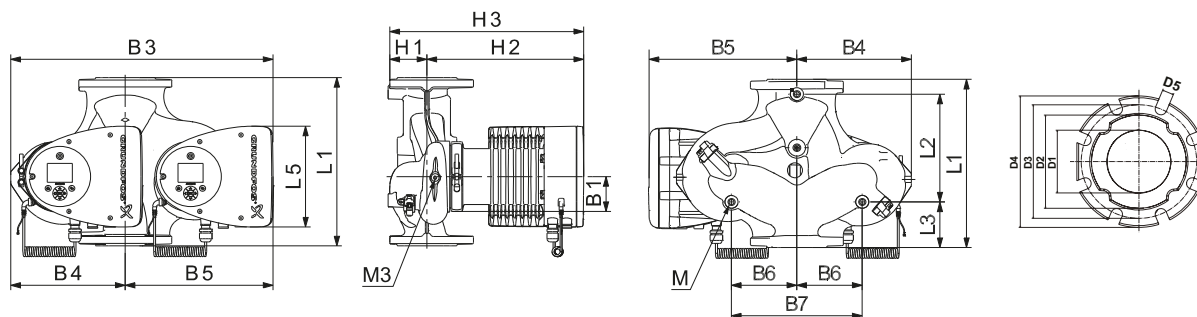

TM05 7701 1214

Pump type	Dimensions [in (mm)]								
	L1	L2	L3	L4	L5	B1	B3	B4	B5
MAGNA3 D 100-120 F	17.72 (450)	9.57 (243)	5.79 (147)	5.79 (147)	8.03 (204)	3.31 (84)	21.69 (551)	9.92 (252)	11.77 (299)
	D1	D2	D3	D4	D5	M	M1	H1	H2
	3.94 (100)	6.3 (160)	7.52 (191)	8.66 (220)	0.75 (19)	M12	Rp 1/4	4.06 (103)	12.99 (330)

For product numbers, see page 68.

11. Accessories

Insulating kits for applications with ice buildup

The accessory is for single-head MAGNA pumps used in applications with ice build-up.

The accessory set consists of two polyurethane (PUR) shells and metal clamps to ensure tight assembly.



TM05 2874 0412

Fig. 59 Fitting the insulating shells to a MAGNA3 pump

Note: The dimensions of the insulating shells differ from those of the insulating shells for heating systems. You can use the insulating shells for both stainless-steel and cast-iron pumps.

Pump type	Product number
MAGNA3 25-40/60/80/100/120 (N)	98354534
MAGNA3 32-40/60/80/100/120 (N)	98354535
MAGNA3 32-40/60/80/100 F (N)	98354536
MAGNA3 32-120 F (N)	98063287
MAGNA3 40-40/60 F (N)	98354537
MAGNA3 40-80/100 F (N)	98063288
MAGNA3 40-120/150/180 F (N)	98145675
MAGNA3 50-40/60/80 F (N)	98063289
MAGNA3 50-100/120/150/180 F (N)	98145676
MAGNA3 65-40/60/80/100/120 F (N)	96913593
MAGNA3 65-150 F (N)*	99608813
MAGNA3 80-40/60/80/100/120 F*	98134265
MAGNA3 100-40/60/80/100/120 F*	96913589

* If the control box of the pump is turned, the insulating shells are not applicable. Please contact Grundfos.

Not all variants are available in all markets.

Specifications:

- Specific volume resistance greater than or equal to 10^{15} Ωcm , DIN 60093
- thermal conductivity at 10 °C 0.036 W/mK and at 40 °C 0.039 W/mK, DIN 52612
- density 33 ± 5 kg/m^3 , ISO 845
- working temperature range -40/+90 °C, ISO 2796.

CIM modules

A CIM module is an add-on Communication Interface Module. The CIM module enables data transmission between the pump and an external system, for example a BMS or SCADA system.

The CIM module communicates via fieldbus protocols. The following CIM modules are available:

Module	Fieldbus protocol	Product number
CIM 050	GENIbus	96824631
CIM 100	LonWorks	96824797
CIM 200	Modbus RTU	96824796
CIM 260	US 3G/4G cellular	99439306
CIM 280	GRM 3G/4G	99439724
CIM 300	BACnet MS/TP	96893770
CIM 500	Ethernet	98301408

Note: Use booster functional profiles for twin-head pumps.

For further information about data communication via CIM modules, see the CIM documentation available in Grundfos Product Center.

Location of CIM module

The CIM module is fitted behind the front cover. See fig. 60.

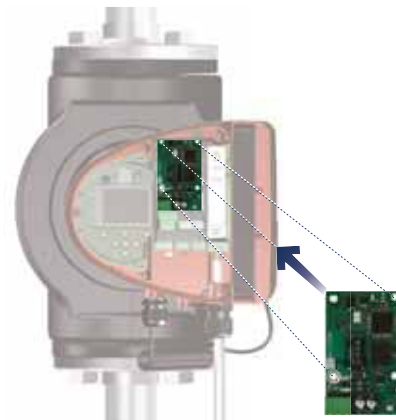

TM05 2914 1112

Fig. 60 Location of CIM module

For installation instructions, please go to:



net.grundfos.com/qr/i/99332342

Reuse of CIM modules

You can reuse a CIM module in a CIU unit used together with Grundfos MAGNA in MAGNA3. You must re-configure the CIM module before you use it in a MAGNA3 pump. Contact your local Grundfos company.



TM05 2911 1312

Fig. 61 Reusing CIM modules

Grundfos GO Remote

Grundfos GO is used for infrared or radio communication with the pumps.

Various Grundfos GO variants are available. The variants are described in the following.

MI 301

The Grundfos GO Remote MI 301 module has built-in infrared and radio communication. Use MI 301 in conjunction with an Android or iOS-based smart device with a Bluetooth connection. MI 301 has a rechargeable Li-ion battery and must be charged separately.



TM05 3890 1712

Fig. 62 MI 301

Supplied with the product:

- Grundfos MI 301
- battery charger
- quick guide.

Product numbers

Grundfos GO variant	Product number
Grundfos MI 301	98046408

External Grundfos sensors

Combined relative-pressure and temperature transmitter

Sensor	Type	Supplier	Measuring range [psi (bar)]	Measuring range [°F (°C)]	Transmitter output [VDC]	Power supply [VDC]	Process connection	Product number
Combined pressure and temperature sensor	RPI T2	Grundfos	0-232 (0-16)	14 to 248 (-10 to +120)	0-10	16.6 - 30	G 1/2	98355521

Note: MAGNA3 has only one analog input.

Pressure sensor

Sensor	Type	Measuring range [psi]	Measuring range [bar]	Transmitter output [mA]	Power supply [VDC]	Process connection	Product number
Pressure transmitter	RPI	0-9	(0 - 0.6)	4 to 20	12 to 30	G 1/2	97748907
		0-15	(0 - 1.0)				97748908
		0-25	(0 - 1.6)				97748909
		0-35	(0 - 2.5)				97748910

11.1 Adapters

Adapter	Product number
Adapter for 1/4" NPT	98344015

DPI V.2 transmitter

Combined differential-pressure and temperature transmitter

Scope of delivery:

- DPI V.2 transmitter
- open 6.5 ft (2 m) cable with M12 connection in one end
- capillary tube with fitting
- quick guide.



TM04 7866 2510

Fig. 63 DPI V.2 transmitter

Sensor	Measuring range [psi (bar)]	Measuring range [°F (°C)]	Transmitter output	Power supply [VDC]	Temperature measurement	O-ring	Process connection	Product number
						EPDM*		
Grundfos DPI	0 - 8.7 (0 - 0.6)	32-212 (0-100)	4-20 mA 0-10 VDC	12.5 - 30 16.5 - 30	•	•	G 1/2	97747194
						•		97747202
Grundfos DPI	0 - 14.5 (0 - 1.0)	32-212 (0-100)	4-20 mA 0-10 VDC	12.5 - 30 16.5 - 30	•	•	G 1/2	97747195
						•		97747203
Grundfos DPI	0 - 23.2 (0 - 1.6)	32-212 (0-100)	4-20 mA 0-10 VDC	12.5 - 30 16.5 - 30	•	•	G 1/2	97747196
						•		97747204
Grundfos DPI	0 - 36.26 (0 - 2.5)	32-212 (0-100)	4-20 mA 0-10 VDC	12.5 - 30 16.5 - 30	•	•	G 1/2	97747197
						•		97747205

* **Note:**
EPDM: approved for potable water.
FKM: for use in oily media.

Cable for sensors

Description	Length [ft (m)]	Product number
Screened cable	6.5 (2.0)	98374260
Screened cable	16.4 (5.0)	98374271

Blanking flange

The accessory is used to blank off the opening when one of the pump heads of a twin-head pump is removed for service to enable uninterrupted operation of the other pump.

The accessory set consists of a blanking flange and a fastener set.

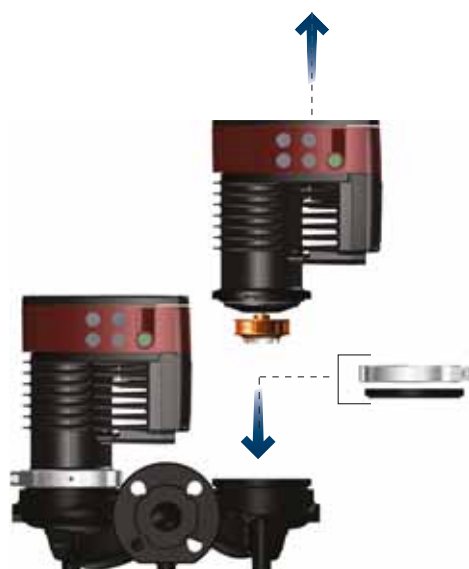

TM06 8518 0817

Fig. 64 Position of a blind flange

Pump type	Product number
MAGNA3 D 32-40/60/80/100 (F)	98159373
MAGNA3 D 40-40/60 F	
MAGNA3 D 32-120 F	98159372
MAGNA3 D 40-80/100/120/150/180 F	
MAGNA3 D 50-40/60/80/100/120/150/180 F	
MAGNA3 D 65-40/60/80/100/120/150 F	
MAGNA3 D 80-40/60/80/100/120 F	
MAGNA3 D 100-40/60/80/100/120 F	

Not all variants are available in all markets.

Pipe connections

The accessory is designed to go from the pump to the pipe, working as an adapter with a specific extension length depending on the adapter type.

The accessory set includes everything you need for installation.

Flange-flange adapters

Material	Flange	Description	Part number	
Cast iron	GF 15/26 flange	3/4" NPT flange fitting set	519601	
		1" NPT flange fitting set	519602	
		1-1/4" NPT flange fitting set	519603	
		1-1/2" NPT flange fitting set	519604	
	GF 40/43 flange	1-1/2" NPT flange fitting set	539605	
	GF 50 flange	2" NPT flange fitting set	96409354	
	GF 53 flange	2" NPT flange fitting set	91584910	
		2-1/2" NPT flange fitting set	91584911	
		3" NPT flange fitting set	91584912	
		GF 65 flange	2-1/2" NPT flange fitting set	559601
		GF 80 flange	3" NPT flange fitting set	569601
	GF 100 flange	4" NPT flange fitting set	579801	
	Stainless steel	GF 65 flange	Stainless steel, 2-1/2" NPT flange fitting set	91121951
Replacement flange gaskets				
GF 15/40		2-bolt, single o-ring for 1-1/2" flange	98476425	

12. Product numbers

Single-head pumps

Single-head pump type	Port-to-port length [in. (mm)]	Flange connection	Cast iron		Stainless steel (N)		Page
			115 V	208-230 V	115 V	208-230 V	
MAGNA3 32-60 F (N)	6 - 1/2 (165)	GF		98126820		98126822	46
MAGNA3 32-100 F (NA)	6 - 1/2 (165)	GF		98126824		98126826	47
MAGNA3 32-120 F (N)	6 - 1/2 (165)	GF		99833304		99833308	48
MAGNA3 40-80 F (N)	8 - 9/16 (216)	GF	98126800	98126828	98126802	98126830	49
MAGNA3 40-120 F (N)	8 - 9/16 (216)	GF	98126804	98126832	98126806	98126834	50
MAGNA3 40-180 F (N)	8 - 9/16 (216)	GF	98126808	98126836	98126810	98126838	51
MAGNA3 50-80 F (N)	9 - 1/2 (240)	DN50	98126812	98126840	98126814	98126842	52
MAGNA3 50-120 F (N)	11 - 1/16 (280)	DN50	99833473	99833476	99833475	99833477	53
MAGNA3 50-150 F (N)	11 - 1/16 (280)	DN50	98126816	98126844	98126818	98126846	54
MAGNA3 50-180 F (N)	11 - 1/16 (280)	DN50	99833480	99833483	99833481	99833485	55
MAGNA3 65-120 F (N)	13 - 7/16 (340)	DN65	98124696	98126848	98124702	98126850	56
MAGNA3 65-150 F (N)	13 - 7/16 (340)	DN65	-	98126852	-	98126854	57
MAGNA3 80-100 F (N)	14 - 3/16 (360)	DN80	-	98126856	-	98126858	59
MAGNA3 100-120 F (N)	17 - 3/4 (450)	DN100	-	98126860	-	98126862	61

Twin-head pumps

Twin-head pump type	Port-to-port length [in. (mm)]	Flange connection	Cast iron		Stainless steel (N)		Page
			115 V	208-230 V	115 V	208-230 V	
MAGNA3 D 65-150 F	13 - 7/16 (340)	DN65	-	98126863	-	-	58
MAGNA3 D 80-100 F	14 - 3/16 (360)	DN80	-	98126864	-	-	60
MAGNA3 D 100-120 F	17 - 3/4 (450)	DN100	-	98126865	-	-	62

Note: Click on the product number and go directly to the performance curve in Grundfos Product Center.

13. Grundfos Product Center

Online search and sizing tool to help you make the right choice.

<http://product-selection.grundfos.com>

All the information you need in one place

Performance curves, technical specifications, pictures, dimensional drawings, motor curves, wiring diagrams, spare parts, service kits, 3D drawings, documents, system parts. The Product Center displays any recent and saved items - including complete projects - right on the main page.

Downloads

On the product pages, you can download installation and operating instructions, data booklets, service instructions, etc. in PDF format.



TM07 2384

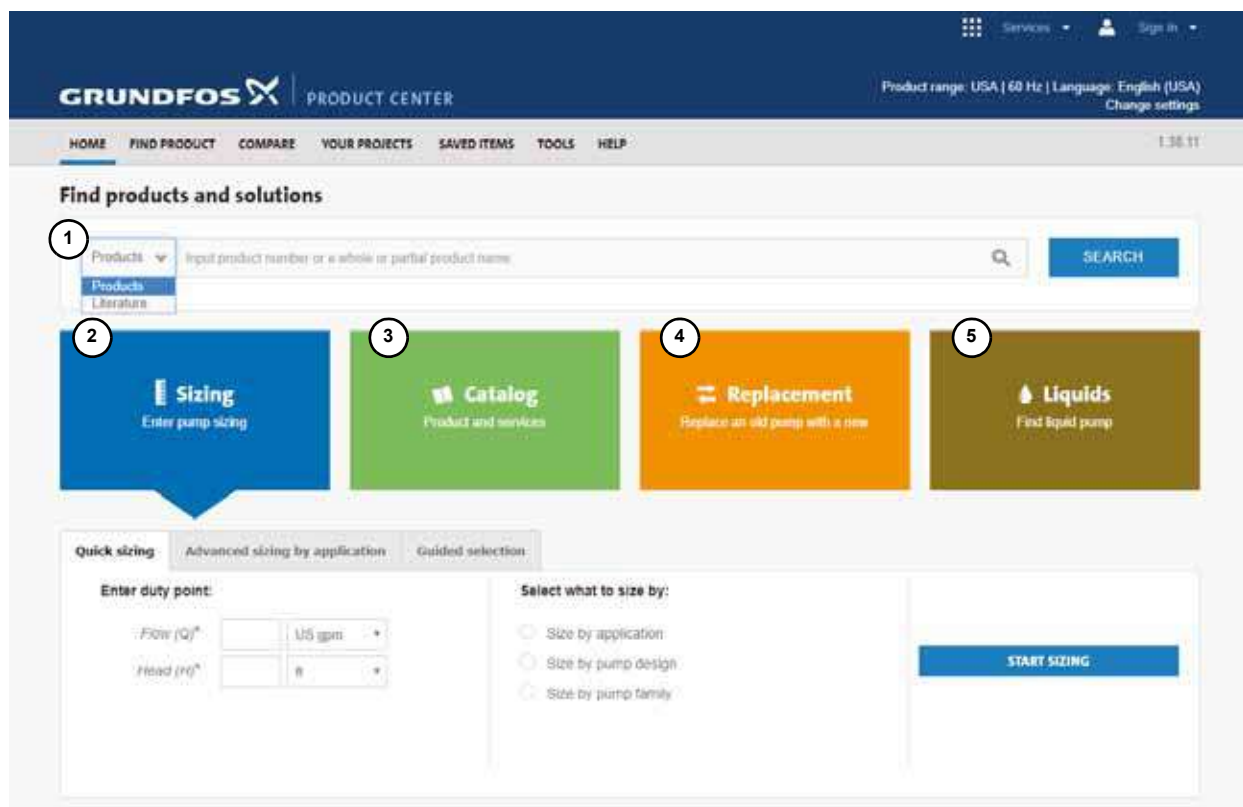

TM07 2383

Pos.	Description
1	This drop-down menu enables you to set the search function to "Products" or "Literature".
2	SIZING enables you to size a pump based on entered data and selection choices.
3	CATALOGUE gives you access to the Grundfos product catalogue.
4	REPLACEMENT enables you to find a replacement product. Search results will include information on <ul style="list-style-type: none"> the lowest purchase price the lowest energy consumption the lowest total life cycle cost.
5	LIQUIDS enables you to find pumps designed for aggressive, flammable or other special liquids.

- the lowest purchase price
- the lowest energy consumption
- the lowest total life cycle cost.

Grundfos GO

Mobile solution for professionals on the GO!

Grundfos GO is the mobile tool box for professional users on the go. It is the most comprehensive platform for mobile pump control and pump selection including sizing, replacement and documentation. It offers intuitive, handheld assistance and access to Grundfos online tools, and it saves valuable time for reporting and data collection.

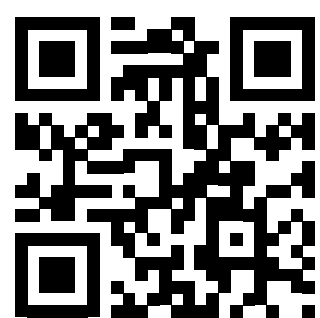

99332363 01.2021

ECM: 1303101

Grundfos Kansas City

9300 Loiret Boulevard
Lenexa, Kansas 66219
Phone: 913-227-3400
Fax: 913-227-3500
www.grundfos.us

Grundfos Canada

2941 Brighton Road
Oakville, Ontario L6H 6C9 Canada
Phone: +1-905-829-9533
Fax: +1-905-829-9512
www.grundfos.ca

Grundfos México

Boulevard TLC No. 15
Parque Industrial Stiva Aeropuerto
C.P. 66600 Apodaca, N.L. Mexico
Phone: 011-52-81-8144 4000
Fax: 011-52-81-8144 4010
www.grundfos.mx