

GRUNDFOS BULLETIN DISTRIBUTION FORM

Title: CM 1.5HP Motors Upgraded to IE3

Bulletin Number: CM-2016-31-08

To: Grundfos Partners

CM 1.5HP Motors Upgraded to IE3

The 1.4 and 1.7 HP CM motors will be updated from IE2 to IE3 motors. The models affected by this change will be the CM 1-8, CM 1-9, CM 3-5, CM 5-3, and CM 10-1. These pumps are changing from either 1.04 or 1.28 kW to 1.1 kW (1.5 HP) IE3 motors. These CM pumps with the IE3 motors will have changes to the dimensions and to the start current compared to IE2. The pumps changing from 1.28 to 1.1 kW motors (CM 10-1 & CM 1-9) will not see a dimension change.

Length dimensions L1, L8, and L9 will increase by 20 mm going to 1.1 kW. The CM 3-6 goes from 1.28 kW to 2.2 kW and all dimensions except L4 will increase.

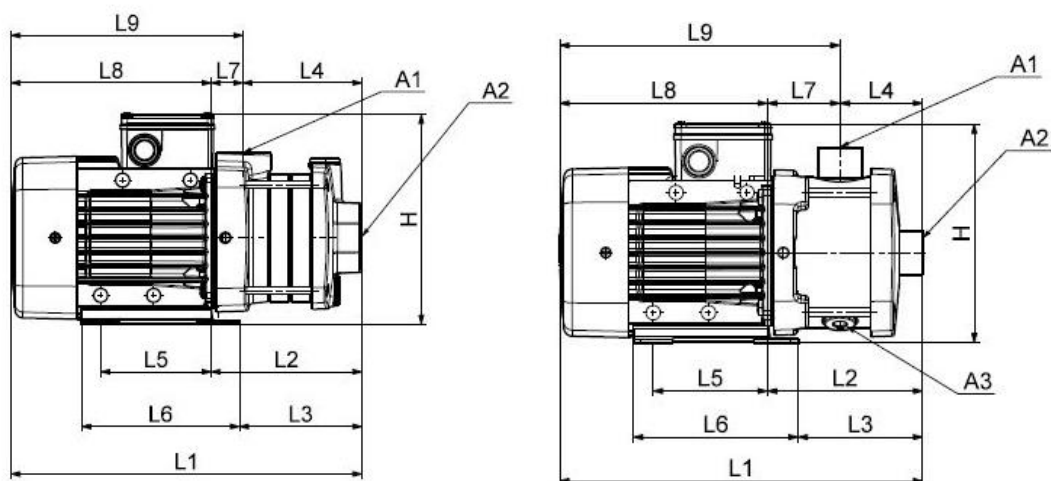

Pump Type	Part Number	Motor Power [kW]	Efficiency																
				B1	B2	B3	H	H1	H2	L1	L2	L3	L4	L5	L6	L7	L8	L9	
CM1-8 A-S-I-E-AQQE E-A-A-N	98091789	1.04	IE2	141	158	125	191.4	74.9	165.2	453.8	240	215.5	179.6	96	137	60.4	213.8	274.2	
CM1-8 A-S-I-E-AQQE E-A-A-N	99080196	1.1	IE3	141	158	125	191.4	74.9	165.2	473.8	240	215.5	179.6	96	137	60.4	233.8	294.2	
CM3-5 A-S-A-E-AQQE E-A-A-N	97568361	1.04	IE2	141	158	125	191.4	74.9	148.4	379.9	166.1	141.6	138.7	96	137	27.4	213.8	241.2	
CM3-5 A-S-A-E-AQQE E-A-A-N	99080189	1.1	IE3	141	158	125	191.4	74.9	148.4	399.9	166.1	141.6	138.7	96	137	27.4	233.8	261.2	
CM3-5 A-S-I-E-AQQE E-A-A-N	97568354	1.04	IE2	141	158	125	191.4	74.9	165.2	381.8	168	143.5	107.6	96	137	60.4	213.8	274.2	
CM3-5 A-S-I-E-AQQE E-A-A-N	99080198	1.1	IE3	141	158	125	191.4	74.9	165.2	401.8	168	143.5	107.6	96	137	60.4	233.8	294.2	
CM3-6 A-S-I-E-AQQE E-A-A-N	97765243	1.28	IE2	141	158	125	191.4	74.9	165.2	437.8	204	179.5	143.6	96	137	60.4	233.8	294.2	
CM3-6 A-S-I-E-AQQE E-A-A-N	99059758	2.2	IE3	178	178	140	207.3	93.4	183.7	510.5	246.1	231.1	143.6	125	155	102.5	264.4	366.9	
CM5-3 A-S-A-E-AQQE E-A-A-N	97568450	1.04	IE2	141	158	125	191.4	74.9	148.4	343.9	130.1	105.6	102.7	96	137	27.4	213.8	241.2	
CM5-3 A-S-A-E-AQQE E-A-A-N	99059730	1.1	IE3	141	158	125	191.4	74.9	148.4	363.9	130.1	105.6	102.7	96	137	27.4	233.8	261.2	
CM5-3 A-S-I-E-AQQE E-A-A-N	97568442	1.04	IE2	141	158	125	191.4	74.9	165.2	345.8	132	107.5	71.6	96	137	60.4	213.8	274.2	
CM5-3 A-S-I-E-AQQE E-A-A-N	98907035	1.1	IE3	141	158	125	191.4	74.9	165.2	365.8	132	107.5	71.6	96	137	60.4	233.8	294.2	

The IE3 upgrade will take effect immediately for the CM 1-8, CM 3-5, and CM 5-3 pumps with I and G stainless steel configurations. The CM 1-9 pump with I and G configurations will upgrade to IE3 by the end of October 2016. We anticipate that the IE3 upgrade for the CM 3-5

GRUNDFOS BULLETIN DISTRIBUTION FORM

and CM 5-3 pumps with A configuration will take place by the end of the year 2016. The CM 10-1 pumps with the A configuration for cast iron will take the IE3 change in early 2017.

Although the efficiency has increased, the price has not. Grundfos is offering the IE3 motor for the same price as the previous model. Please refer to the attached CM Crossover List for pricing. The new motor allows for higher ambient temperatures, going from a maximum of 55 degrees Celsius to 60 degrees Celsius.

Thank you for your continued support of Grundfos Pumps. If you have any questions please do not hesitate to contact Grundfos.

Sincerely,
GRUNDFOS PUMPS CORPORATION

Brian Holmes
Regional Product Specialist