



# REPAIR PARTS

---

## CPLE090 - 120 Light Commercial Condensing Units, Gray Models

CPLE090-3C  
CPLE090-4C  
CPLE120-3C  
CPLE120-4C

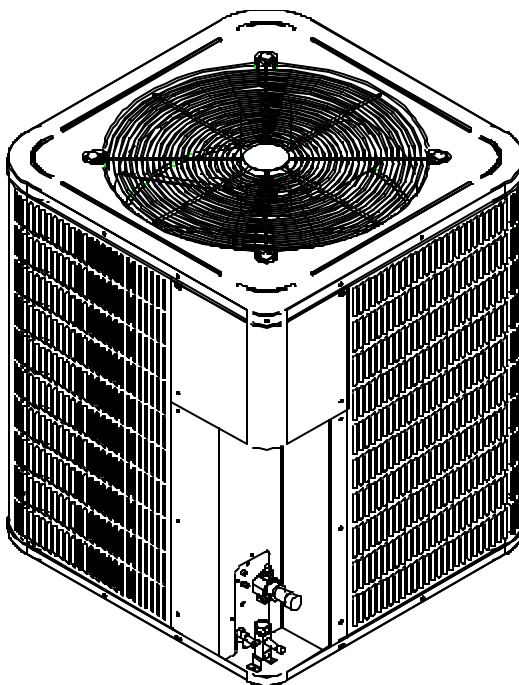

RP - 327  
September 2004

Made in the USA by:  
Goodman Manufacturing Company, L.P.  
2550 North Loop West, Suite 400  
Houston Texas 77092

This manual is to be used by qualified technicians only.

Copyright © 2004 Goodman Manufacturing Company, L.P.

## Important Information

---

Goodman Manufacturing Company, L.P. is not responsible for personal injury or property damage resulting from improper service. Review all service information before beginning repairs.

Warranty service must be performed by an authorized technician, using authorized factory parts. If service is required after the warranty expires, Goodman Manufacturing Company, L.P. also recommends contacting an authorized technician and using authorized factory parts.

For assistance within the U.S.A. contact:

Consumer Affairs Department  
Goodman Manufacturing Company, L.P.  
7401 Security Way  
Houston, Texas 77040  
877-254-4729-Telephone  
713-863-2382-Facsimile

For assistance outside the U.S.A. contact:

International Division  
Goodman Manufacturing Company, L.P.  
7401 Security Way  
Houston, Texas 77040  
713-861-2500-Telephone  
713-863-2382-Facsimile

# Index

Functional Parts List .....	5
Illustration and Parts .....	6 - 7

*Views shown are for parts illustrations only, not servicing procedures.*

## **Text Codes:**

AR - As Required

NA - Not Available

NS - Not Shown

00000000 - See Note

QTY - Quantity Example (QTY 3) (If Quantity not shown, Quantity = 1)

M - Model Example (M1) (If M Code not shown, then part is used on all Models)

## **Expanded Model Nomenclature:**

Example
M1 - Model#1
M2 - Model#2
M3 - Model#3

This page left blank intentionally.

# Functional Parts

## Part

## No: Description:

---

B1226212	ACCUMULATOR
B945673	CAPACITOR, 20MFD, 440 VAC
ZR108KCTF5950	COMPRESSOR, ZR108KC-TF5-250, OLD PN# B9266385 (M3)
ZR108KCTFD950	COMPRESSOR, ZR108KC-TFD-250, OLD PN# B9266384 (M4)
ZR84KCTF5950	COMPRESSOR, ZR84KC-TF5-250, OLD PN# B9266383 (M1)
ZR84KCTFD950	COMPRESSOR, ZR84KC-TFD-250, OLD PN# B9266382 (M2)
B1243732	CRANK CASE HEATER 460V 50/60HZ, 75 WATTS (M2, M4)
B1243749	CRANKCASE HEATER, 208/230-50/60, 75 WATTS (M1, M3)
1262233	CRATED COND. SERVICE COIL W/DRIER (M1, M2)
1262234	CRATED COND. SERVICE COIL W/DRIER (M3, M4)
B1226008S	DEFROST CONTROL, TIMER
B1370803	DEFROST THERMOSTAT
B3232211	EXPANSION VALVE/TUBING ASSEMBLY (M1, M2)
	This is an assembly consisting of B1284657 (EXPANSION VALVE) + B3232209 (DISTRIBUTOR ASSEMBLY).
B3232212	EXPANSION VALVE/TUBING ASSEMBLY (M3, M4)
	This is an assembly consisting of B1284657 (EXPANSION VALVE) + B3232210 (DISTRIBUTOR ASSEMBLY).
B1086768	FAN, 3 BLADE, 30° PITCH, 26" DIAMETER
B1219227	FILTER DRIER, STEEL, BI-FLOW, 5/8" X 5/8"
B1360721	HIGH PRESSURE SWITCH
B1360719	LOW PRESSURE SWITCH
B13400354	MOTOR, FAN, 208/230-60-1, 1 SPD, 1100 RPM, 1 HP (M1, M3)
B13400355	MOTOR, FAN, 460-60-1, 1 SPD, 1100 RPM, 1 HP (M2, M4)
B1370751	RELAY
B1227312	VALVE, REVERSING (M1, M2)
B1227313	VALVE, REVERSING (M3, M4)

### SPECIAL PARTS

IO-229	INSTALLATION AND OWNERS MANUAL
RP-294	REPAIR PARTS MANUAL
B260S8292	SPRAY PAINT TOUCH UP (DARK GRAY)

### Expanded Model Nomenclature

M1 - CPLE090-3C
M2 - CPLE090-4C
M3 - CPLE120-3C
M4 - CPLE120-4C

# Chassis

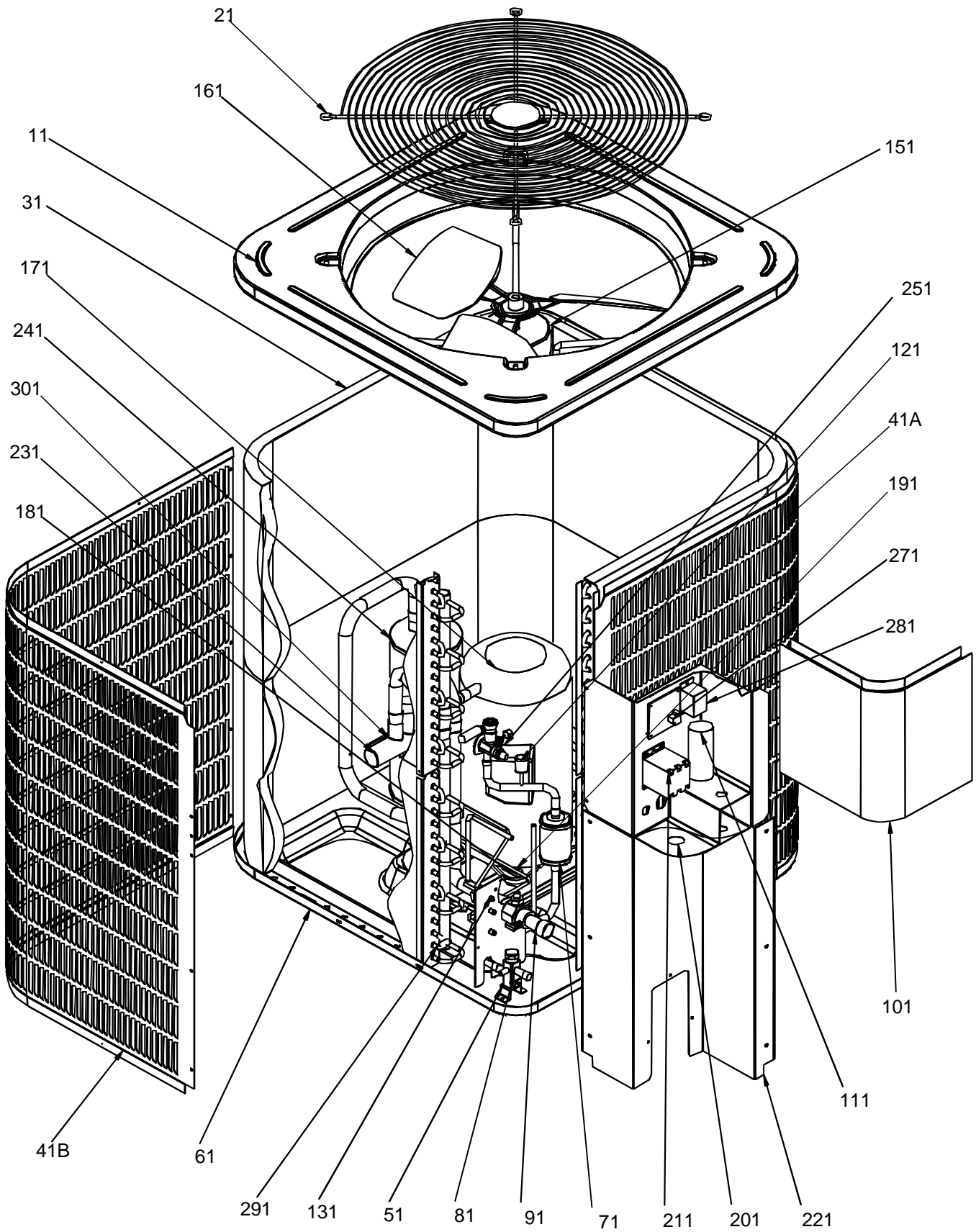

# Chassis

## Ref. Part

No: No:

Description:

## Ref. Part

No: No:

Description:

Image 1:

11	4279400PDG	TOP PANEL, 35"
21	B1376925	FAN GRILL GUARD
31	1262233	CRATED COND. SERVICE COIL W/DRIER (M1, M2)
31	1262234	CRATED COND. SERVICE COIL W/DRIER (M3, M4)
41	4203404PDG	PANEL, LOUVER, 40.0", HAIRPIN SIDE 41A
41	4203405PDG	PANEL, LOUVER, 40.0", RETURN SIDE 41B
51	4223709	SUPPORT BRACKET
61	4279100PDG	PAN, BOTTOM, 35.0"
71	B1219227	FILTER DRIER, STEEL, BI-FLOW, 5/8" X 5/8"
81	B1282573	BASE VALVE, LIQUID LINE, 5/8" X 5/8"
91	B1282574	BASE VALVE, SUCTION LINE 1 1/8" X 1 1/8"
101	4223701P	CONTROL BOX COVER
111	B945673	CAPACITOR, 20MFD, 440 VAC
121	B1360719	LOW PRESSURE SWITCH
131	B1360721	HIGH PRESSURE SWITCH
151	B13400354	MOTOR, FAN, 208/230-60-1, 1 SPD, 1100 RPM, 1 HP (M1, M3)
151	B13400355	MOTOR, FAN, 460-60-1, 1 SPD, 1100 RPM, 1 HP (M2, M4)
161	B1086768	FAN, 3 BLADE, 30° PITCH, 26" DIAMETER
171	ZR108KCTF5950	COMPRESSOR, ZR108KC-TF5-250, OLD PN# B9266385 (M3)
171	ZR108KCTFD950	COMPRESSOR, ZR108KC-TFD-250, OLD PN# B9266384 (M4)
171	ZR84KCTF5950	COMPRESSOR, ZR84KC-TF5-250, OLD PN# B9266383 (M1)
171	ZR84KCTFD950	COMPRESSOR, ZR84KC-TFD-250, OLD PN# B9266382 (M2)
181	B1339533	GROMMET, COMPRESSOR (QTY 4)
191	B1243732	CRANK CASE HEATER 460V 50/60HZ, 75 WATTS (M2, M4)
191	B1243749	CRANKCASE HEATER, 208/230-50/60, 75 WATTS (M1, M3)
201	4287600	CONTROL BOX
211	B1360335	CONTACTOR, 3 POLE, 240/277, 24V
221	42237009PDG	PANEL, ACCESS, LOWER, 40.0"
231	B1227312	VALVE, REVERSING (M1, M2)
231	B1227313	VALVE, REVERSING (M3, M4)
241	B1226212	ACCUMULATOR
251	B3232211	EXPANSION VALVE/TUBING ASSEMBLY (M1, M2) This is an assembly consisting of B1284657 (EXPANSION VALVE) + B3232209 (DISTRIBUTOR ASSEMBLY).
251	B3232212	EXPANSION VALVE/TUBING ASSEMBLY (M3, M4) This is an assembly consisting of B1284657 (EXPANSION VALVE) + B3232210 (DISTRIBUTOR ASSEMBLY).
271	B1226008S	DEFROST CONTROL, TIMER
281	B1370751	RELAY
291	B1370803	DEFROST THERMOSTAT
301	B1225020	SOLENOID CORD
NS	B1376926	MOTOR MOUNTING BRACKET
NS	B1393025	PLASTIC GRILL FASTENER (QTY 4) (QTY 4)
NS	B1372801	SIGHT GLASS
NS	B260S8292	SPRAY PAINT TOUCH UP (DARK GRAY)

Expanded Model Nomenclature

M1 - CPLE090-3C
M2 - CPLE090-4C
M3 - CPLE120-3C
M4 - CPLE120-4C