

1



# AHU SERIES 1

## Germicidal UV Light Installation Instructions

The Fresh-Aire UV® AHU Series 1 is installed inside the air handling system to reduce biological contamination for reduced system maintenance and improved indoor air quality.

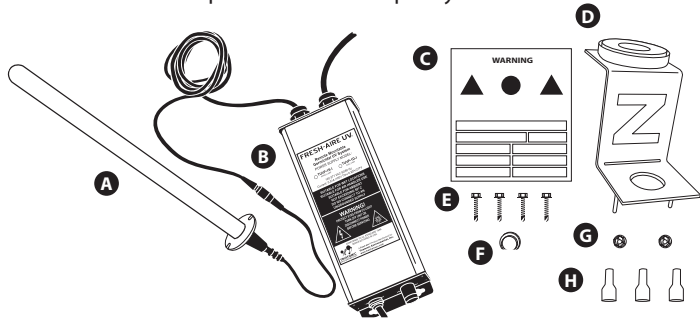

US patent #7,704,463

### IMPORTANT!

- Only qualified technicians should install this product\*
- Install in accordance with relevant building codes
- Read instructions carefully including safety warnings

© Fresh-Aire UV

TUV-AHU-MAN 032017

\*Installation of this product by anyone other than licensed HVAC or electrical contractors voids warranty.

### Parts Included

- A** UV Lamp
- B** Power Supply
- C** UV Warning Sticker
- D** "Z" Mounting Bracket
- E** Self-Tapping Screws
- F** Sight Glass
- G** Quick-Nut (plastic)
- H** Spade Connectors

## 2 Installation Notes

Before installing Fresh-Aire UV® AHU Series 1 it is necessary to determine the optimal mounting location inside the air system. First, look for the area with the heaviest mold growth. Also consider a location that will allow the germicidal UV light to shine on the greatest surface area. For enhanced anti-microbial effect 2 or more lamps can be installed in different parts of the air system.

Some typical mounting locations:

- A** Supply-side duct
- B** At the blower
- C** Across top of coils
- D** Coil face
- E** Coil "A" plate
- F** Return-side duct

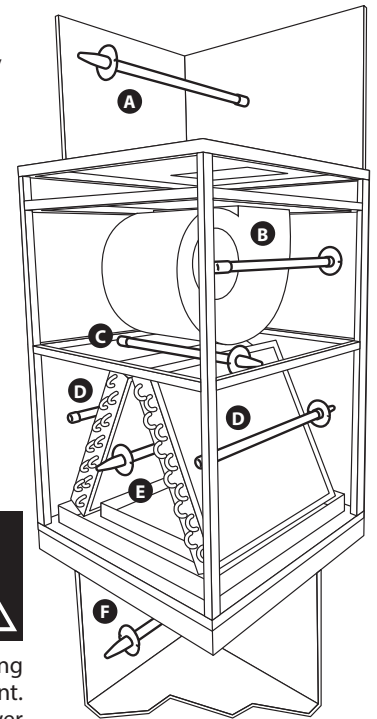

UV Lamp Mounting Options

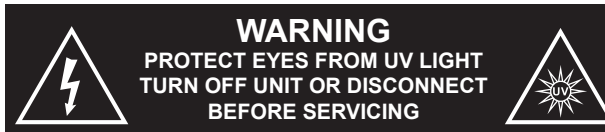

**Important:** some materials inside the air system (including filter media, flex duct, wiring etc.) may not be UV light resistant. Use the optional UV shield (part #TUV-SHIELD-LPC) or cover the materials with reflective tape.

## 3 Air Handler Interior Surface Installation

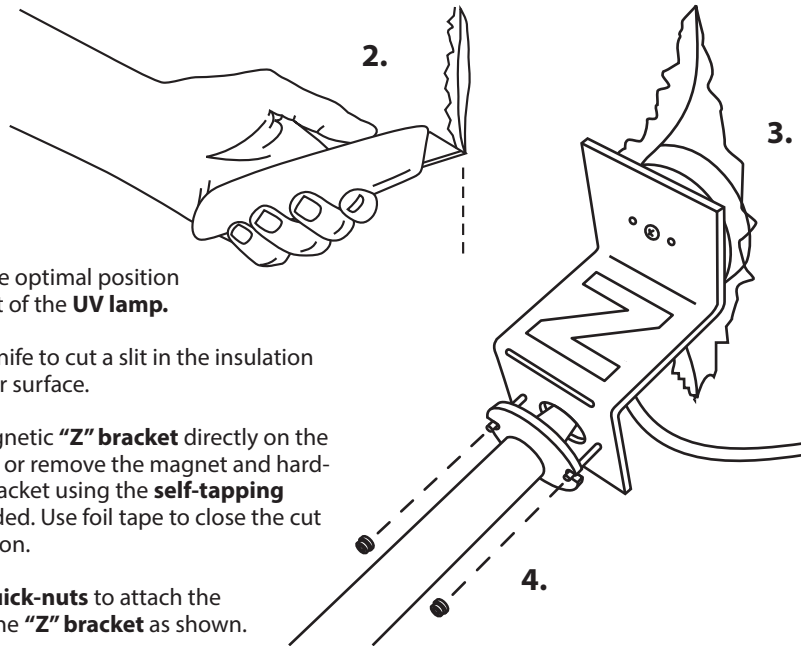

1. Determine the optimal position for placement of the **UV lamp**.
2. Use a utility knife to cut a slit in the insulation on the interior surface.
3. Place the magnetic **"Z" bracket** directly on the metal surface or remove the magnet and hard-mount the bracket using the **self-tapping screws** provided. Use foil tape to close the cut in the insulation.
4. Use plastic **quick-nuts** to attach the **UV lamp** to the **"Z" bracket** as shown.

## 4 Coil "A" plate Installation

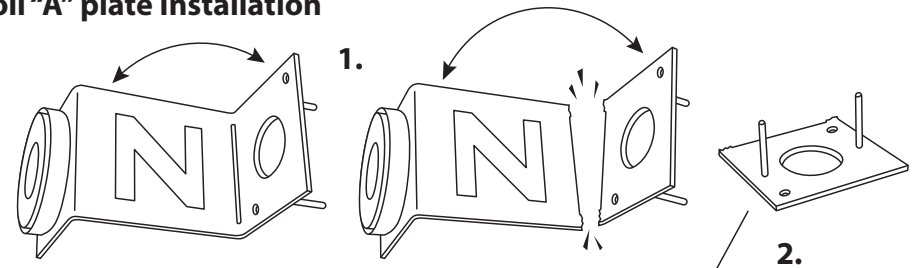

1. Snap the **"Z" bracket** apart by bending.
2. Drill a 1" hole in the "A"-plate then attach the smaller piece of the bracket using the **self-tapping screws**.
3. Insert the **UV lamp** into the hole then use the plastic **quick-nuts** to attach the **UV lamp** to the **"Z" bracket** as shown.

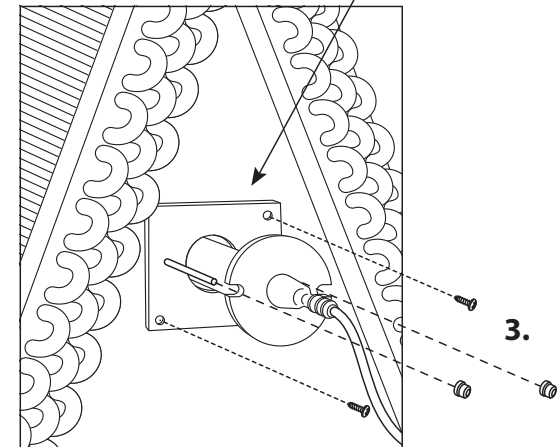

## 5 Power Supply Installation

1. Find a suitable location for the **power supply** outside or inside the air handler/furnace. Install the **power supply** in a location that allows easy access to the power switch to turn on/off the UV light for servicing. Install using the **self-tapping screws**.
2. Use the wiring diagram to properly connect to 110 - 277 VAC power.

TUVP-1S-1D Power Supply  
for Single & Dual Lamps

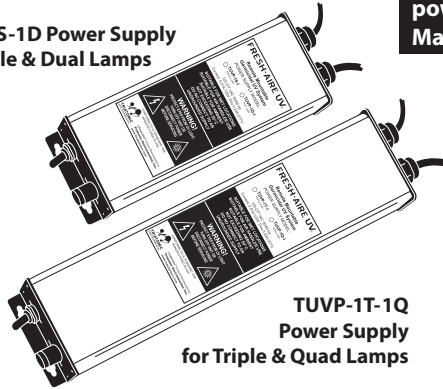

**IMPORTANT! Must be wired to constant power - do not connect to blower relay. Make sure unit is properly grounded.**

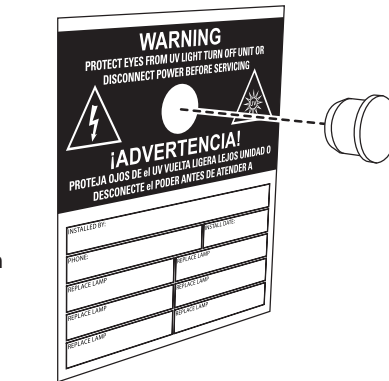
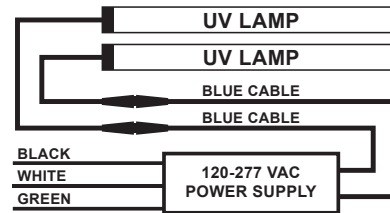

## 7 Sight Glass Installation

1. Find a suitable location on the outside of the duct-work near the UV Lamp installation and apply the Fresh-Aire UV® warning/lamp replacement sticker.
2. Drill a 1/2" hole through the orange circle on the sticker. Press the UV safety viewport into hole.
3. Turn on the main power then turn on the switch on the UV light power supply. Use the sight glass to confirm that the UV Lamp is operating.

## 8 Lamp Replacement

The germicidal UV lamp in Fresh-Aire UV® AHU Series 1 needs to be replaced periodically. TUVL-115P and TUVL-115P-OS (odor control) lamps should be replaced every year. TUVL-215P and TUVL-215P-OS should be replaced every 2 years. Note: UV lamps will continue to emit visible light but lose germicidal effectiveness over time. You can upgrade to a 2 year and/or odor control lamp with your existing power supply.



TUVL-115P & TUVL-115P-OS



TUVL-215P & TUVL-215P-OS

**Note:** Use of replacement UV lamps other than Fresh-Aire UV® voids warranty.  
**Caution:** UV lamps contain small amounts of mercury - dispose of lamps in accordance with local environmental regulations. For more information visit [www.lamprecycle.org](http://www.lamprecycle.org)

## Connecting to Power

The power supply for this unit is available as a 120 VAC plug-in or hard-wired version. If a local 120 VAC receptacle is not available, the system can be directly connected to the power supply of the air handling system by hard-wiring the unit to the main electrical feed of the air handler.

## 6 UV Lamp Connection

1. When all the other components are properly installed connect the UV Lamp cable(s) to the power supply cable(s).
2. Make sure the flanges are aligned and then push the connectors firmly together. A tight connection ensures a proper water-resistant seal.

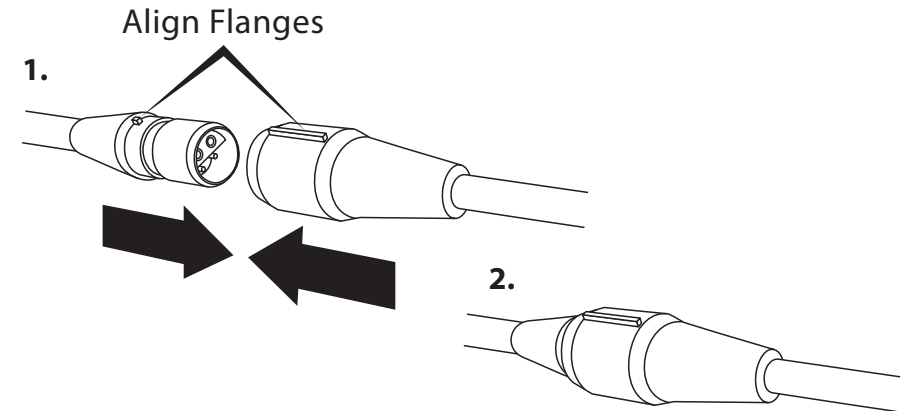

## Manufacturer's Warranty:

This warranty supersedes and replaces any warranty statements orally made by the Sales Person, Distributor or Dealer or contained in the written instructions or other Brochures or informational documents in relation to this product. This warranty gives you specific legal rights, and you may also have other rights which vary from State to State.

**What Does This Warranty Cover?** This lifetime limited manufacturer warranty covers any defects or malfunctions in material and workmanship under the normal use and service when operated and maintained in strict accordance with manufacturer's instructions for the Lifetime of the equipment.

**How Long Does The Coverage Last?** 1) Power Supply: For as long as you own the real property where the product is installed. 2) TUVL-1XX Series Ultraviolet Lamp is warranted for germicidal output for one-year from the date of installation. 3) TUVL-2XX Series Ultraviolet Lamp is warranted for germicidal output for two (2) years from the date of installation. This warranty is not transferable.

**What Will Triatomic Environmental, Inc. Do?** Triatomic Environmental, Inc. will replace any defective or malfunctioning part at no charge. You must pay any labor charges and shipping charges of defective product to our warranty department.

**What Does This Warranty Not Cover?** THIS PRODUCT IS NOT INTENDED TO BE PURCHASED AND INSTALLED BY UNLICENSED HVAC OR ELECTRICAL CONTRACTORS. This warranty does not cover products or parts purchased from any source other than licensed HVAC or electrical contractors. This warranty does not cover parts installed by unlicensed HVAC or electrical contractors. This warranty does not cover parts damaged as a result of misuse, abuse, or any use other than its intended use, accident, acts of god, neglect, or from improper operation, maintenance, installation, modification or adjustments. Triatomic Environmental, Inc. shall have no responsibility for charges incurred by the customer for installation or removal of warranted items.

This warranty does not cover parts or equipment used with the Fresh-Aire UV system that are not manufactured by Triatomic Environmental, Inc.

**\*\*This warranty shall be void if UV lamps from manufacturer's other than Triatomic Environmental, Inc. are used with this equipment.**

Consequential and incidental damages are not recoverable under this warranty. Manufacturer assumes no liability for any harm, which may occur as a result of the use of the equipment herein and shall not be liable for consequential or any other damages whether or not caused by manufacturer's negligence or resulting from any express or implied warranty or breach thereof. Consequential damages for the purpose of this warranty shall include, but not be limited to, loss of use, income or profit, or loss of or damages to property or injury or death to persons or animals occasioned by or arising out of operation, use, the operation, installation, repair or replacement of the equipment or otherwise. Some states do not allow the exclusion or limitation of incidental or consequential damages, so the above limitation or exclusion may not apply to you.

There are no Warranties which extend beyond the description of the face hereof.

**How Do You Get Service?** In order to be eligible for service under this warranty you MUST return the warranty registration card or register online at [www.freshaireuv.com](http://www.freshaireuv.com). If something is wrong with your product, call your installing contractor to receive a Return Merchandise Authorization (RMA) and instructions for returning the product to a licensed distributor in your area or the manufacturer.

Once the product is returned, we will inspect your product and contact you within 10 business days of our receipt of the product to give the results of our inspection. If we determine that the product is covered under this warranty, we will ship to you at no additional cost a replacement part. Replacement parts may be refurbished. If we determine that the product is not covered under this warranty, or that this warranty is void, the product will be returned to you COD. There is no charge for inspection.

**How Does State Law Apply?** This warranty gives you specific legal rights, and you may also have other rights which vary from state to state.