

DETAIL A

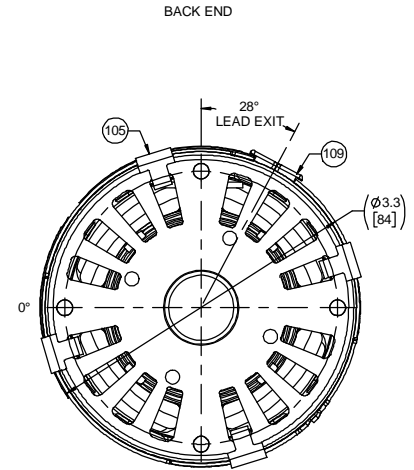

LEAD MATERIAL
 18 GA. 125°C, 2/64 INSUL.
 X-LINKED POLY. (2) BLACK
 14.00/12.00 [355.6/304.8]
 WITH .56/ .44 [14.2/11.2] STRIP
 GROUND LEAD
 GRNYEL
 14.00/12.00 [355.6/304.8]
 W/ RING TERM. AMP 350436-2

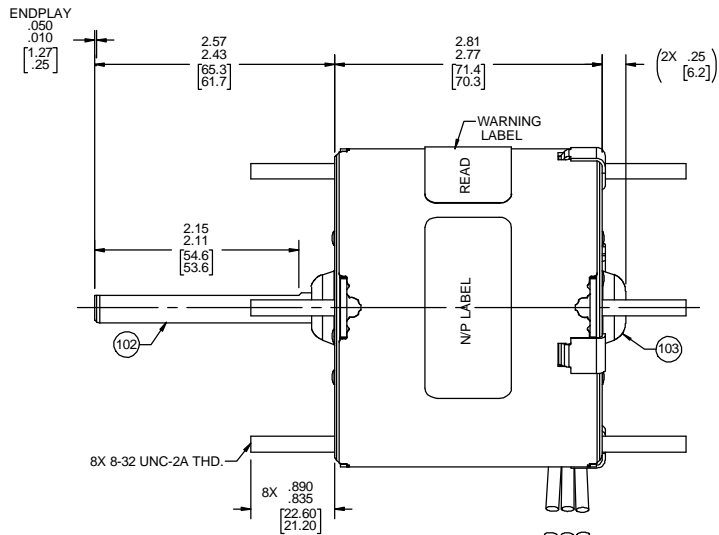
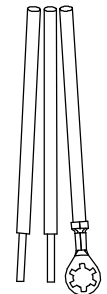

- NOTES:**
 1. SHAFT MATERIAL IS 416 SS
 2. NO PACKING TAPE OVER CARTON LABEL

61305568

00464668

SAFETY WARNING
 This motor must be grounded in accordance with local or national electrical codes to prevent possible injury due to electrical shock

AVERTISSEMENT DE SÉCURITÉ
 Ce moteur doit être fondée sur conformément à la réglementation locale ou national électrique codes pour prévenir d'éventuelles blessures en raison de choc électrique

FASCO Fasco Industries, Inc
 Motor Division

Assembled in Mexico

No. 71732144 TYPE U73B1 T.P. AO
 115 V 60 Hz Class B
 1.7 A 1550 RPM 1/25 HP E40513
 Model D0030
 Max. Amb: 40°C

| | | | |
|--|-------------|------------------|---------------|
| CUSTOMER: | FASCO DIST. | APPLICATION: | COUNTER SALES |
| CUSTOMER PN: | D0030 | MOTOR WEIGHT: | |
| | UP | ENVIRONMENT: | DRY |
| MOTOR TYPE | | REFERENCE SAMPLE | |
| SHADED POLE | | X-0006173-2 | |
| B | LA | FR | A |
| 00 | 73 | 30 | V |
| | | 05 | FW |
| | | | E |
| | | | B |
| | | | A |
| | | | 0 |
| TYPICAL PERFORMANCE AT 115 VOLTS 60 HZ | | | |
| IDLE | | LOADED | |
| | | LOCKED | |
| | | BREAK | |
| MOTOR SPEED | RPM | AMP | WATT |
| | 1750 | 1.50 | 82 |
| | | 34.3 | 1550 |
| | | 1.72 | 123 |
| | | 15.0 | 2.54 |
| | | 179 | 40.8 |

| | | | | | |
|---|-------------|---------------|--|------------------------|----------------------------|
| DRAWING REVISION | REVISION BY | REV DATE/DATE | TOLERANCES (EXCEPT AS NOTED): | DRAWN BY | Regal Beloit America, Inc. |
| DA | MH | 3/18/2020 | DEC .INCH .mm ANGLE | MH | |
| ECO-0183449 | APPROVED BY | DATE | .XX ±0.1 [±0.3] | 3/18/2020 | |
| ECO DESCRIPTION | SDM | 3/18/2020 | .XXX ±0.005 [±0.13] | SDM | |
| CHG NIP LABEL LAYOUT, ADDED WARNING LABEL | | | .XXX ±0.005 [±0.13] | | |
| | | | .XXX ±0.005 [±0.13] | | |
| | | | REMOVE BURRS & BREAK SHARP EDGES: .003/.015 [08/.38] X 45° | | |
| | | | CORNER FILLETS: R.02 [±.5] | | |
| | | | MACHINED SURFACES: .125/ .3/ .5 INCH/mm | | |
| | | | mm DIMENSIONS IN [BRACKETS] | | |
| | | | ARE FOR REFERENCE ONLY | | |
| | | | | THIRD ANGLE PROJECTION | |
| | | | | SIZE C | |
| | | | | DRAWING NUMBER | |
| | | | | 71732144 | |
| | | | | PROCESS/FINISH | |
| | | | | BLACK | |
| | | | | SHEET | |
| | | | | 1 OF 2 | |

