

ATMO™ 150H

Fresh Air Appliance (Heat Recovery Ventilator)

Product #: 463888



Fantech's side port connection HRV for budget conscious house projects, the ATMO 150H unit brings a continuous supply of fresh air into a home while exhausting an equal amount of contaminated air. During winter, fresh incoming air is tempered by the heat that is transferred from the outgoing air so you save on energy costs, while during summer, the incoming air is pre-cooled if the house is equipped with an air cooling system. The ATMO 150H is equipped with automatic defrost mechanisms so you can use your HRV all year long.

Features

- Compact design
- Fans with backward curved blade
- Electrostatic filters (washable)
- Polypropylene heat recovery core
- Removable screw terminal for easy connection with external access
- Lightweight 44 lbs (20Kg)
- Multiple speed operation

Optional Controls

- ECO-Touch™ – Programmable Touch Screen Wall Control
- ECO-Feel™ – Automatic IAQ Control
- EDF8 – Electronic multi-function dehumidistat
- EDF3 – Multi-function control
- RTS-W – Wireless 20/40/60 minute timer
- RTS5 – 20/40/60 minute over-ride
- RTS2 – 20 minute over-ride
- MDEH1 – Dehumidistat

Specifications

- Duct size – 6" (152 mm)
- Voltage/Phase – 120/1
- Power rated – 168 W
- Amp – 1.4 A
- Average airflow – 161 cfm (76 L/s)
@ 0.4" P_s (100Pa)

Fans

Two (2) factory-balanced fans with backward curved blades. Motors come with permanently lubricated, sealed ball-bearings to guarantee long life and maintenance-free operation.

Heat Recovery Core

Polypropylene heat recovery core covered by a limited lifetime warranty. Core dimensions are 12" x 12" (305 x 305 mm) with a 10" (254 mm) depth. Our heat exchangers are designed and manufactured to withstand extreme temperature variations.

Defrost

A preset defrost sequence is activated at an outdoor air temperature of 23°F (-5°C) and lower. During the defrost sequence, the supply blower shuts down & the exhaust blower switches into high speed to maximize the effectiveness of the defrost strategy. The unit then returns to normal operation, and continues cycle.

Serviceability

Core, filters, fans and drain pan can be easily accessed through latched door. Core conveniently slides out on our new easy glide core guides. 17" (432 mm) of clearance is recommended for removal of core.

Case

22 gauge galvanized steel cabinet with a pre-painted steel corrosion resistant door.

Insulation

Cabinet is fully insulated with 3/4" (19 mm) high density expanded polystyrene.

Filters

Two (2) washable electrostatic panel type air filters 10" (254 mm) x 11.9" (302 mm) x 0.125" (3 mm).

Controls

External three (3) position (Low/Stand By/Medium) rocker switch that will offer continuous ventilation. Fantech offers a variety of external controls. (see controls)

Installation

Unit is typically hung by using installation kit supplied with unit. Mounting chains inserted on hooks located on top four (4) corners of unit. An optional wall bracket is available.

Warranty

Limited lifetime on polypropylene core, 7 year on motors, and 5 year on parts.

Dimensions & Airflow

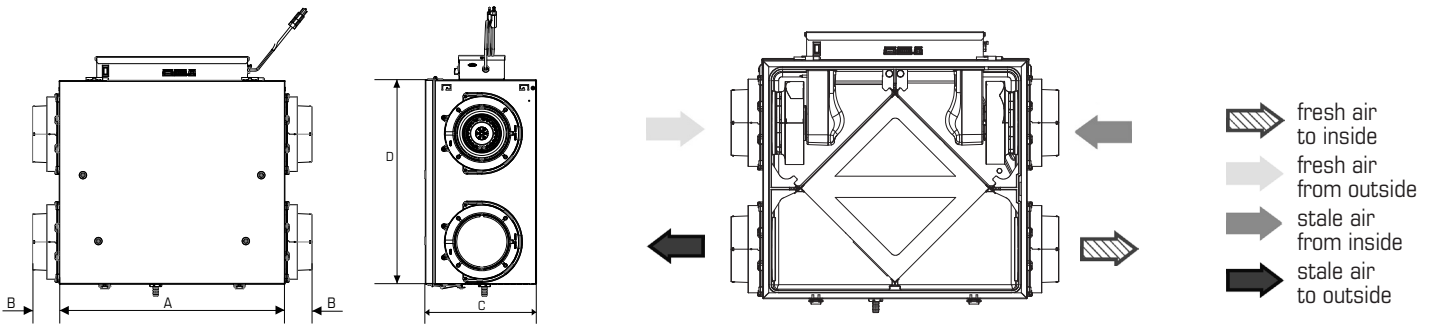

Model	A		B		C		D	
	in	mm	in	mm	in	mm	in	mm

ATMO 150H 23 7/8 606 29 1/2 750 11 11/16 297 21 7/16 546

Clearance of 17" (432 mm) in front of the unit is recommended for removal of core. All units feature three foot plug-in power cord with 3-prong plug.

Ventilation Performance

in.wg. (Pa)	0.1 (25)	0.2 (50)	0.3 (75)	0.4 (100)	0.5 (125)	0.6 (150)	0.7 (175)	0.8 (200)
	cfm (L/s)	cfm (L/s)	cfm (L/s)	cfm (L/s)	cfm (L/s)	cfm (L/s)	cfm (L/s)	cfm (L/s)
Net supply airflow	199 (94)	186 (88)	174 (82)	161 (76)	148 (70)	133 (63)	121 (57)	108 (51)
Gross supply airflow	203 (96)	191 (90)	178 (84)	165 (78)	153 (72)	138 (65)	125 (59)	112 (53)
Gross exhaust airflow	208 (98)	195 (92)	182 (86)	170 (80)	157 (74)	142 (67)	129 (61)	117 (55)

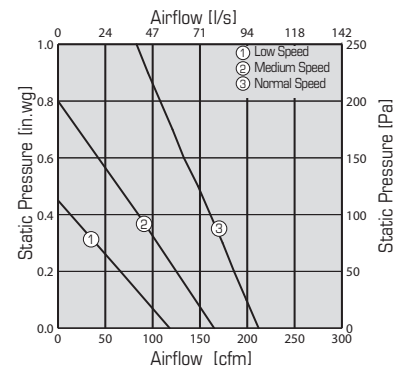

Energy performance

Heating	Supply temperature		Net Airflow		Power	Sensible recovery efficiency	Adjusted sensible recovery efficiency	Latent recovery / moisture transfer
	°F	°C	cfm	L/s	W	%	%	
	32	0	64	30	54	74	80	0.00
	32	0	148	70	109	65	70	0.00
	-13	-25	66	31	55	60	63	0.00

Requirements and standards

- Complies with the UL 1812 requirements regulating the construction and installation of Heat Recovery Ventilators
- Complies with the CSA C22.2 no. 113 Standard applicable to ventilators
- Complies with the CSA F326 requirements regulating the installation of Heat Recovery Ventilators
- Technical data was obtained from published results of test relating to CSA C439 Standards

Contacts

Submitted by:	Date:
Quantity: Model:	Project #:
Comments:	
Location:	
Architect:	
Engineer:	Contractor:

Distributed by:

United States 10048 Industrial Blvd. • Lenexa, KS 66215 • 1.800.747.1762 • www.fantech.net

Canada 50 Kanafilakt Way • Bouctouche, NB E4S 3M5 • 1.800.565.3548 • www.fantech.net

Fantech, reserves the right to modify, at any time and without notice, any or all of its products' features, designs, components and specifications to maintain their technological leadership position.