

## FIT® 120E-D-EC Fresh Air Appliance (FAA/ERV)

Product #: 463404



Powered by EC motors, the ENERGY STAR® rated FIT 120E-D-EC fresh air appliance proves that energy efficiency and performance truly can co-exist.

The FIT 120E-D-EC, designed for multi-family applications, brings a continuous supply of fresh air into the premises while exhausting an equal amount of contaminated air out. As such, the energy recovery core transfers both heat and moisture from the outgoing exhaust air to the incoming fresh air, reducing the energy required to condition it.

### Features

- Compact design
- Electronically commutated (EC) motors
- No drain required
- Mechanical shutoff damper
- Easy to install on ceiling or wall with mounting bracket included
- Energy recovery core
- Electrostatic filters (washable)
- Removable screw terminal for easy connection with external access
- Multiple speed operation
- Lightweight

### Recommended Controls

- ECO-Feel® AUTO IAQ – Automatic IAQ Control

### Also Compatible With

- ECO-Touch® AUTO IAQ – Programmable Touch Screen Wall Control
- EDF8 – Electronic multi-function dehumidistat
- EDF3 – Multi-function control
- RTS-W – Wireless 20/40/60 minute over-ride
- RTS5 – 20/40/60 minute over-ride
- RTS2 – 20 minute over-ride
- MDEH1 – Dehumidistat

### Specifications

- Duct size – 5 in. (125 mm) round
- Voltage/Phase – 120/1
- Rated power – 74W
- Maximum amperage – 2.3 A
- Average airflow – 129 cfm (61 L/s) @ 0.4 in. wg (100Pa)
- Weight – 35lbs (16kg) including core



Download  
BIM model  
and Specs



### Fans

Two (2) electronically commutated motors. EC motors use intelligent technology to reduce energy usage that results in lower operating costs, less maintenance over the lifetime of the unit, and increased longevity of the motor.

### Mechanical Shutoff Damper

To avoid drawing outside air directly into the air handling unit when the unit is not operating, this unit is equipped with a mechanical shut-off damper. Constructed of polymer material, the damper is activated by a non fail-safe actuator.

### Energy Recovery Core

Energy recovery core made from water vapor transport durable polymer membrane that is highly permeable to humidity. The ERV core is freeze tolerant, water washable, and is resistant to mold and bacteria. Core dimensions are 12 in. x 12 in. (305 x 305mm) with a 8.15 in. (207mm) depth.

### Frost Prevention

A preset frost prevention sequence is activated at an outdoor air temperature of 14°F (-10°C) and lower. During the sequence, the supply blower shuts down, the mechanical shutoff damper closes & the exhaust blower switches into high speed to maximize the effectiveness of the frost prevention strategy. The unit then returns to normal operation, and continues the cycle.

### Serviceability

Core, filters, fans and electronic panel can be accessed easily. Core conveniently slides out with only 8.5 in. (216mm) clearance.

### Duct Connections

5 in. (125mm) round metal duct connections with rubberized seal

### Case

22 gauge galvanized steel cabinet with a pre-painted steel corrosion resistant door.

### Insulation

Insulated with 3/4 in. (20 mm) high density expanded polystyrene.

### Filters

Two (2) washable electrostatic panel type air filters 11.3 in. (287mm) x 8.15 in. (207mm) x 0.125 in. (3mm).

### Installation

Unit is typically hung by using ceiling bracket supplied with unit. Optional chain kit available.

### Limited Warranty

5 years on energy recovery core, 7 year on motors, and 5 year on parts.



**fantech**®  
a systemair company

## Dimensions & Airflow

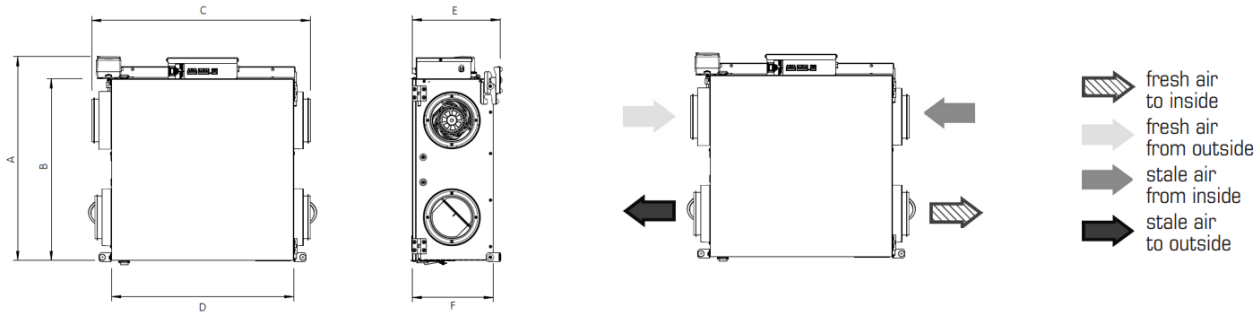

| Model         | A      |     | B      |     | C  |     | D      |     | E  |     | F     |     |
|---------------|--------|-----|--------|-----|----|-----|--------|-----|----|-----|-------|-----|
|               | in     | mm  | in     | mm  | in | mm  | in     | mm  | in | mm  | in    | mm  |
| FIT 120E-D-EC | 23 5/8 | 600 | 20 3/4 | 527 | 25 | 634 | 20 7/8 | 529 | 10 | 254 | 9 1/4 | 235 |

Clearance of 8.5 in. (216mm) in front of the appliance is recommended for removal of core. All appliances feature three foot plug-in power cord with 3-prong plug.

## Ventilation Performance

| in. wg. (Pa)          | 0.1 (25)  | 0.2 (50)  | 0.3 (75)  | 0.4 (100) | 0.5 (125) | 0.6 (150) | 0.7 (175) | 0.8 (200) |
|-----------------------|-----------|-----------|-----------|-----------|-----------|-----------|-----------|-----------|
|                       | cfm (L/s) | cfm (L/s) | cfm (L/s) | cfm (L/s) | cfm (L/s) | cfm (L/s) | cfm (L/s) | cfm (L/s) |
| Net supply airflow    | 153 (72)  | 146 (69)  | 138 (65)  | 129 (61)  | 119 (56)  | 108 (51)  | 97 (46)   | 85 (40)   |
| Gross supply airflow  | 157 (74)  | 150 (71)  | 142 (67)  | 133 (63)  | 123 (58)  | 112 (53)  | 100 (47)  | 89 (42)   |
| Gross exhaust airflow | 157 (74)  | 148 (70)  | 140 (66)  | 129 (61)  | 119 (56)  | 108 (51)  | 95 (45)   | 83 (39)   |

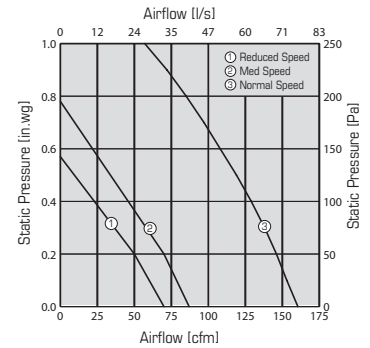

## Energy performance

|         | Supply temperature |     | Net airflow |     | Consumed power | Sensible recovery efficiency | Adjusted sensible recovery efficiency | Latent recovery/moisture transfer   |
|---------|--------------------|-----|-------------|-----|----------------|------------------------------|---------------------------------------|-------------------------------------|
|         | °F                 | °C  | cfm         | L/s | W              | %                            | %                                     | %                                   |
| Heating | 32                 | 0   | 51          | 24  | 23             | 77                           | 80                                    | 74                                  |
|         | 32                 | 0   | 70          | 33  | 28             | 71                           | 74                                    | 70                                  |
|         | 32                 | 0   | 125         | 59  | 62             | 64                           | 67                                    | 61                                  |
|         | -13                | -25 | 51          | 24  | 24             | 61                           | 62                                    | 53                                  |
|         | Supply temperature |     | Net Airflow |     | Power          | Total recovery efficiency    | Adjusted total recovery efficiency    | Latent recovery / moisture transfer |
|         | °F                 | °C  | cfm         | L/s | W              | %                            | %                                     | %                                   |
| Cooling | 95                 | 35  | 51          | 24  | 22             | 70                           | 72                                    | 70                                  |

## Requirements and standards

- Complies with the UL 1812 requirements regulating the construction and installation of Heat Recovery Ventilators
- Complies with the CSA C22.2 no. 113 Standard applicable to ventilators
- Complies with the CSA F326 requirements regulating the installation of Heat Recovery Ventilators
- Technical data was obtained from published results of test relating to CSA C439 Standards
- HVI certified and ENERGY STAR® qualified\*

\* This product earned the ENERGY STAR® logo by meeting strict efficiency guidelines set by Natural Resources Canada and the US EPA. It meets ENERGY STAR® requirements only when used in Canada.

## Contacts

|                     |                   |
|---------------------|-------------------|
| Submitted by: _____ | Date: _____       |
| Quantity: _____     | Model: _____      |
| Comments: _____     | Project #: _____  |
| Location: _____     |                   |
| Architect: _____    |                   |
| Engineer: _____     | Contractor: _____ |

## Distributed by:

United States 10048 Industrial Blvd. • Lenexa, KS 66215 • 1.800.747.1762 • www.fantech.net

Canada 50 Kanalfakt Way • Bouctouche, NB E4S 3M5 • 1.800.565.3548 • www.fantech.net

Fantech, reserves the right to modify, at any time and without notice, any or all of its products' features, designs, components and specifications to maintain their technological leadership position.