

2GMS1661 Guard Mounted Exh Fan

Item Number: 47092

Variant: 115V 1~ 60Hz

Application

Guard mounted exhaust fans are widely used for ventilating warehouses, greenhouses, workshops and other low pressure applications of up to 0.125 Ps.

Design

Steel wire intake guard complies with OSHA regulations and has four mounting loops to make in stallation easy, and baked-on gray polyester finish to help resist corrosion.



Technical parameters

Nominal data		
Voltage (nominal)	115	V
Frequency	60	Hz
Phase(s)	1~	
Input power	37	W
Input current	1.7	A
Impeller speed	1,550	r.p.m.
Air flow	max 1,060.0	cfm
Minimum static back pressure	0.1	in.wg
Protection/Classification		
Insulation class		B

Dimensions

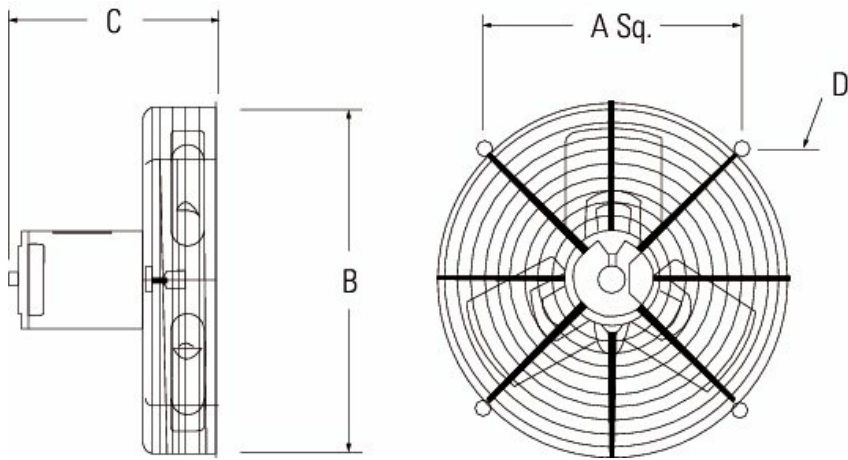

Model	Propeller Dia	A	B	C	D
2GMS 1021	10	8 3/4	11	5 9/16	1/4
2GMS 1221	12	10 3/16	13	5 15/16	1/4
2GMS 1661	16	12 15/16	17 3/8	6 1/2	1/4
2GMS 20B1	20	16 3/4	22 1/8	11 15/16	5/16

Dimensions in inches.

Wiring

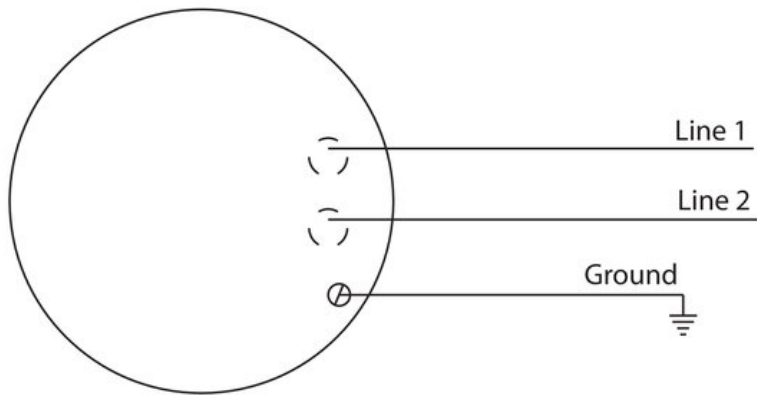

Documents

- 481799 2GMS OIPM.pdf