

# Browning®

## Q-D®

### Instructions

## Emerson Industrial Automation

7120 New Buffington Road  
Florence, KY 41042  
Application Engineering: 800 626 2093  
www.emerson-ept.com

# FORM

F20-23  
Revised  
May 2010

### ⚠ WARNING

- Disconnect and lock-out power before installation and maintenance. Working on or near energized equipment can result in severe injury or death.
- Do not operate equipment without guards in place. Exposed equipment can result in severe injury or death.
- Read and follow all instructions carefully.

### ⚠ CAUTION

- Periodic inspections should be performed. Failure to perform proper maintenance can result in premature product failure and personal injury.
- All electrical work should be performed by qualified personnel and compliant with local and national electrical codes.
- To avoid damage, supporting structure including shafts and bearings must be designed to handle transmitted loads and belt tension(s).

### NOTICE

- Failure to use the cap screws that came with the Product may lead to an unsafe assembly.

### Before Installation:

1. Make sure the shaft, bushing barrel and bore, Q-D bushed product bore, key and keyway are free of burrs, paint etc. Make sure the key, as applicable, will slide in both shaft keyseat and bushing bore keyway.

**NOTICE:** Lubricant on bushing barrel, hub or screws could lead to breakage.

2. For proper operation, make sure the shaft size is within the size limits shown in Table 1. Some applications may benefit from tighter shaft tolerances.

**NOTICE:** Mounting a Q-D® Bushing on a shaft smaller than the size limits shown in Table 1 may result in a faulty assembly. The assembly may come off the shaft or undesirable assembly runout may result.

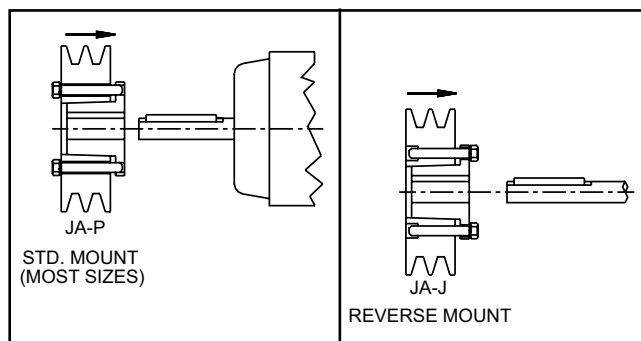

ILLUSTRATION 1A -- QD ASS'Y, FLANGE IN BOARD

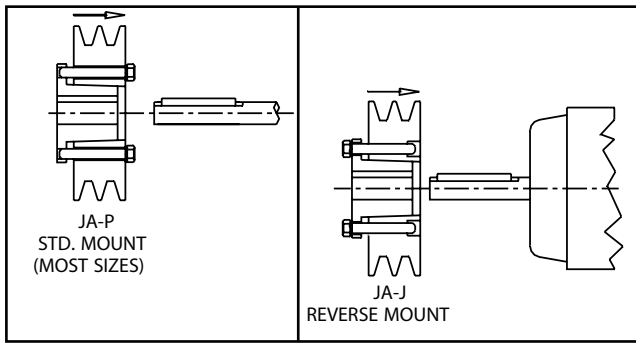

ILLUSTRATION 1B - - QD ASS'Y, FLANGE OUTBOARD

**Mounting:**

- For light weight products, the bushing may first be loosely installed into the Q-D bored product, hereafter referred to as "product", and then the assembly slid onto the shaft (Illustration 1A and B). For heavier products, it is usually easier to either first slide the bushing onto the shaft, then slide the product onto the bushing (Illustration 2A), or first position the product over the shaft, next slide the bushing onto the shaft, and then pull the product onto the bushing (Illustration 2B). The "light weight products" method is common, however if the bushing barrel has collapsed, it must be wedged open (described below), and the "heavy product" procedure may be easier.

Heavier product may require a hoist or other means of holding the product in position until the bushing is inserted into the product. When mounting on a vertical shaft, make sure the bushing and the product do not drop during installation.

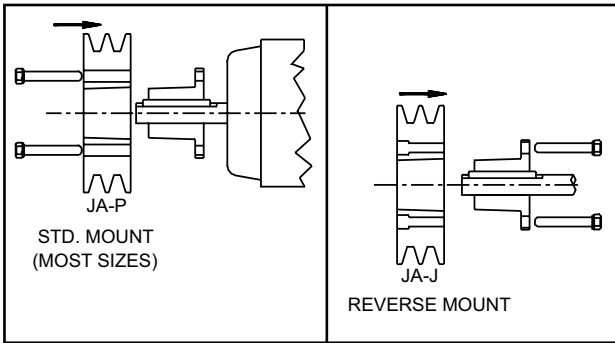

ILLUSTRATION 2A - - QD COMPONENTS, FLANGE INBOARD

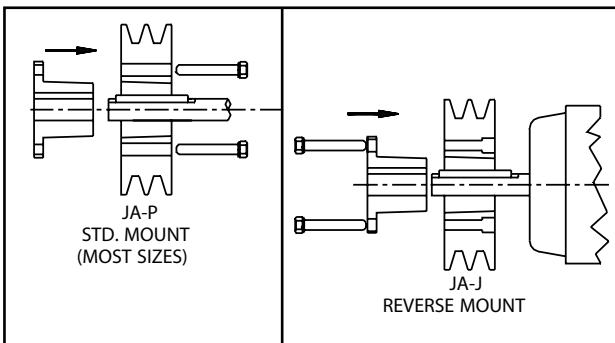
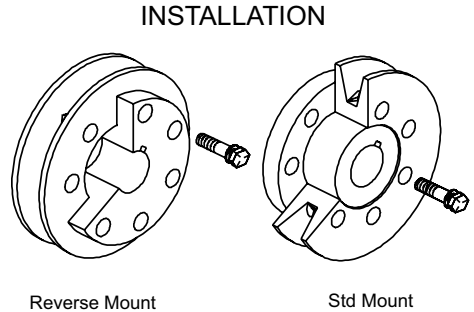

ILLUSTRATION 2B - - QD COMPONENTS, FLANGE OUTBOARD

4. It may be necessary to slightly wedge open the saw slot on some bushings in order to start the bore and position the bushing onto the shaft. A narrow edged regular screw driver may be used.

**NOTICE:** Excessive wedging forces in Bushing saw slot may damage or break Bushing. AVOID.

5. Align the shaft keyseat as applicable with the bushing bore keyway and install the key. Make sure the key runs the entire length of the bushing bore.
6. For standard Q-D mounting, align the non-threaded holes in the product with the threaded holes in the bushing flange. For reverse Q-D mounting, align the non-threaded holes in the bushing flange with the threaded holes in the product. See illustration below. Some Q-D products can only be reverse mounted. Insert the cap screws and thread them by hand three or four turns.



7. Position the bushing - product assembly axially on the shaft such that it is aligned with its running mate. Be sure to check for adequate clearance between the assembly and other nearby components if applicable. If the bushing has a setscrew over the keyway, tighten it to the torque value in Table 2.

**NOTICE:** Tightening the set screw to a torque higher than shown in Table 2 may lead to Bushing damage or breakage. AVOID.

8. If the bushing - product assembly is not between the shaft bearings, then locating the assembly closer to a bearing will reduce the load and increase the life of both bearings. Check for adequate clearance as stated in Step 7.
9. Using a torque wrench and appropriate socket, tighten the capscrews with lock washers sequentially until each is tightened to the torque shown in Table 2. When the capscrew torque is at or near recommended torque, make at least two more sequential rounds to assure all capscrews are at the Table 2 capscrew torque value.

**NOTICE:** Tightening the cap screws to a torque higher than shown in Table 2 may lead to Bushing damage or breakage. AVOID.

10. If cap screws are provided with the product, use them instead of the ones provided with the bushing.
11. Since tightening the capscrews may affect the axial position of the product, confirm that it is still properly aligned with its running mate. If not, determine how much the assembly must be moved to be in proper alignment.
12. If axial adjustment is required, (following removal procedure), reposition the assembly and repeat step 9.
13. Check installation gap - there must be a gap between the bushing flange and the product face. If there is no gap between them, disassemble the parts (following removal procedure) and determine the reason(s) for the faulty assembly.

#### **Removal:**

1. Heavier product may require a hoist or other means of supporting the product during the removal procedure. When removing from a vertical shaft, make sure the bushing and product do not drop during removal.
2. Remove all capscrews sequentially. If the bushing has a keyway setscrew, loosen it.
3. For standard Q-D removal, insert capscrews into all threaded holes in product. For reverse Q-D removal, insert cap screws into all threaded holes in bushing flange. In both cases, insert the removal screws from the same side of the assembly, wherever possible, from which the capscrews were just removed. See illustration on page 4.

4. Tighten the capscrews against the face until the screw force releases the product from the bushing.
5. Remove the bushing and product from the shaft using appropriate means.

## REMOVAL

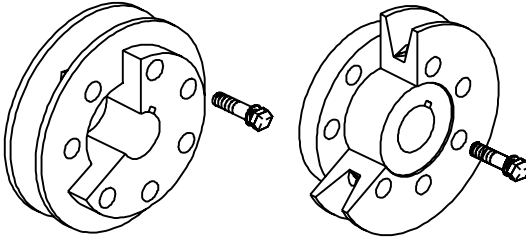

Reverse Removal

Std. Removal

**Table 1: Shaft Size Limits for Q-D Bushings**

Shaft Size Range (IN)		Lower Shaft Size Limit (IN)	Shaft Size Range (MM)		Lower Shaft Size Limit (MM)
Through	Above		Through		
-	1 1/2	-0.003	-	38.1	-0.076
1 1/2	2 1/2	-0.004	38.1	63.5	-0.102
2 1/2	4	-0.005	63.5	101.6	-0.127
4	6	-0.006	101.6	152.4	-0.152
6	8	-0.007	152.4	203.2	-0.178
8	9	-0.008	203.2	228.6	-0.203
9	-	-0.009	228.6	-	-0.229

Note: Upper limit is + 0 whether units are inches or millimeters.

**Table 2: Tightening Torques**

Bushing	SAE Grade 5.1 or 5 Cap Screw		Cap Screw Torque			Set Screw Size	Set Screw Torque		
	No.	Size	(In-Lbs)	(Ft-Lbs)	(N -M)		(In-Lbs)	(Ft-Lbs)	(N -M)
JA	3	#10 -24NC	60	5	6.8	—	—	—	—
SH-SDS-SD	3	1/4 -20NC	108	9	12.2	1/4 -20NC	87	7.25	9.8
SK	3	5/16 -18NC	180	15	20.3	1/4 -20NC	87	7.25	9.8
SF	3	3/8 -16NC	360	30	40.7	5/16 -18NC	165	13.8	18.6
E	3	1/2 -13NC	720	60	81.4	3/8 -16NC	290	24.2	32.8
F	3	9/16 -12NC	900	75	101.7	3/8 -16NC	290	24.2	32.8
J	3	5/8 -11NC	1620	135	183.1	3/8 -16NC	290	24.2	32.8
M	4	3/4 -10NC	2700	225	305.1	3/8 -16NC	290	24.2	32.8
N	4	7/8 -9NC	3600	300	406.8	1/2 -13NC	620	51.7	70.1
P	4	1 -8NC	5400	450	610.2	1/2 -13NC	620	51.7	70.1

(N-M) = Newton Meters

Have questions? Contact Application Engineering at 1-800-626-2093.

