

The new NCM-3z Zone Control System has been enhanced and includes easy menu programming via the large LCD screen. The LCD displays real time “System Status” such as Supply Air Temperature, System Mode of Operation, Fresh Air cycles & Status of the new on-board Safety Interlock. Connect the innovative Data output to our model DAPC, and modulate your EWC zone dampers to control the HVAC system Static Pressure. Easily control 24vac legacy HVAC systems and create 2 or 3 air zones in your home or small business. Use EWC 24vac motorized dampers and any off-the-shelf 24vac thermostats you desire, including WiFi models. Try out the Next Generation NCM-3z Zone Controller and discover why it is the most reliable & technician friendly, residential Zone Controller in the HVAC Industry.

Zone Capacity

Control 2 or 3 air zones with 24vac Power Open/Power Close (*floating point*) dampers. Ultra-Zone® motors (MA-ND5 or MA-15S) are required in order to utilize the DAPC.

Compatible HVAC Systems

Control 24vac 2 Heat / 1 Cool fuel systems (Gas, Oil, Electric, Hydronic). You can also control 2 Heat / 1 Cool standard Heat Pumps.

Compatible Thermostats

The NCM-3z is compatible with typical 24vac single stage Heat/Cool thermostat and 2 Heat/1Cool Heat Pump thermostats. Hard wired, Battery or Power Robbing types are compatible. The NCM-3z is compatible with Smart WiFi thermostats as well, assuming a sufficient number of wires exist at each thermostat location. *See Notes, Page 12.*

Automatic Heat / Cool Changeover

The NCM-3z is compatible with “automatic changeover” thermostat settings, which allows for individual zoned comfort.

Status LCD

System Heat ON

4 Button LCD Programming



The Liquid Crystal Display continuously scrolls to show the status of the Zone system (Heat Mode, Cool Mode, Fan mode or Idle).. The supply air temperature is also displayed including status of the S1/S2 safety circuit.

Four buttons are provided just below the LCD screen. Press Left or Right button to scroll thru the Menu. Then make your selections using the Up & Down buttons. While the screen is scrolling, press the Up or Down buttons to observe Thermostat demands from each zone and other system information.

System LED's

In addition to the LCD, a total of 7 colored LED's provide visual indication of the HVAC system status & zone damper position.

Damper LED's

Three green LED's labeled Zone 1, Zone 2 & Zone 3, provide indication of which zone dampers are energized to the open position.



Figure 1. NCM-3z panel

Digital Damper Position Feature

A “Data” output terminal is provided for use with the Ultra-Zone model DAPC. The “Distributed Air Pressure Controller” can monitor zone damper positions via the NCM-3z (EWCnet) data signal. The DAPC can modulate compatible zone dampers to control the system static pressure at the design or desired set-point. The DAPC also shares the static pressure data with the NCM-3z to display on the LCD.

24vac Accessory Output

The NCM-3z provides a 24vac output that you can use to power accessories like the DAPC modulating damper control, or the SBD2 Smart Bypass Damper.

Fresh Air Feature

On two zone applications, the spare Zone 3 may be used to control a Fresh Air damper. The NCM-3z will calculate “Minutes of Fresh Air” per hour for you, based on several variables. *See page 7 for details.*

Safety (S1 / S2) Interlock Feature

The NCM-3z includes an on-board safety circuit.. The S1/S2 terminals can be connected to “dry contact” wet switches, fire/smoke monitors or refrigerant leak monitors. If the safety device activates, the NCM-3z will shut-down the HVAC system and close all zone dampers, or open all zone dampers but only run the fan. This contractor friendly feature eliminates the question “How do I wire my safety devices” on a zoned HVAC system. *See page 6 & 10 for details.*

INSTALLATION INSTRUCTIONS

The zoned installation shall comply with National and/or Local Mechanical / Building Code including applicable ACCA standards.

MOUNTING: Choose a suitable location to mount the NCM-3z housing. Suitable locations are on the Return Duct, a Nearby Gypsum Wall or Plywood mounted to wall studs. **Do Not** mount the NCM-3z on the Supply duct. **Do Not** mount the NCM-3z directly to the Air-Handler, Furnace, Hydronic Coil Cabinet or Evaporator Cabinet. **Do Not** mount the NCM-3z in an "open" return air stream. **Do Not** mount the NCM-3z inside a clothes closet.

POWER SUPPLY: The NCM-3z requires a **dedicated** 24vac transformer. 40va minimum - 75va maximum. **Do Not steal 24vac power from the HVAC system!** Doing so will void the warranty. The zoned installation shall comply with National and/or Local Electrical Code.

WIRING: Use standard 18awg solid copper multi-conductor cable. Plenum rated where applicable. Connect the dedicated 24vac Power Supply to the NCM-3z and wire-up thermostats and dampers. Use the openings provided on the housing as the wire entry-way. Stripping the cable's jacket back to the point where the cable enters the housing, reduces bulk and allows easy routing of the individual wires for a professional looking installation. Use the wire tie loops to secure the wires.

PROGRAM: Scroll thru the LCD menu and select the type of HVAC system you want to control. You may select the type of thermostat you intend to use (Heat/Cool or Heat Pump) as well. The NCM-3z allows the use of Heat/Cool thermostats with Heat Pump systems. Accept the default supply air sensor temperature limits or you can fine tune them to your liking. **Caution!** Changing menu settings without full knowledge of the feature function, may result in improper or undesired system operation.

FINISH: Program all thermostats for the correct system type and run the system thru it's paces. Observe the HVAC system in all possible modes of operation. Check the Zone Dampers for proper operation and the Bypass Damper (if present) as well. Adjust the NCM-3z menu settings as needed. It's important to "manually balance" the duct work with all zone dampers open, when the system is running at 100% of the rated (CFM) airflow.

NCM-3z code 1.45 SPECIFICATIONS and MENU ITEMS:

NUMBER OF ZONES: 2 or 3 zones. Non-expandable.

COMPATIBLE EQUIPMENT:

24vac Gas/Oil/Electric/Hydronic systems – 1 or 2 Stage Heating and 1 Stage Cooling.
24vac Conventional Heat Pump systems – 1 or 2 Stage Heating and 1 Stage Cooling.

COMPATIBLE THERMOSTATS:

24vac single stage Heat/Cool Thermostats. (WiFi compatible with 4 or 5 wires).
24vac 2 stage Heat, 1 Stage Cool Heat Pump Thermostats. (WiFi compatible with 5 or 6 wires).

COMPATIBLE DAMPERS:

24vac EWC® Models URD, ND, and SID 3 wire (Power Open/Power Close) type dampers.

MAX. DAMPERS PER SYSTEM @ 40va power supply:

ND, URD, or SID Dampers @ (1.5va) per damper motor. **Total 15.**

MAX. DAMPERS PER SYSTEM @ 75va power supply:

ND, URD, or SID Dampers @ (1.5va) per damper motor. **Total 21.**

OVER-CURRENT (Auto-Reset) PROTECTION:

F1 = 300mA OC protection for the Primary Logic Circuit.
F2 - F4 = 750mA OC protection for each Zone Circuit.
F5 = 100mA OC protection for the Data circuit.
NOTE: Solid State OC protection de-rates approx 20% at high ambient temperatures.

NCM-3z Current & Power = 250mA / 6va

(All zones actively heating & all relays energized)(No accessories connected)

POWER SUPPLY = 24vac 50/60 Hz - 50VA recommended

40VA min - 75VA max

AMBIENT OPERATING CONDITIONS:

TEMPERATURE: -4° to 158°F (-20° to 70°C).

HUMIDITY: 0% - 95% Rh Non-Condensing.

HOUSING SPECIFICATIONS:
High Strength Impact Polystyrene.
HB flame rating. UV resistant.

TERMINAL BLOCK SCREW TORQUE: 3.5 inch lb (0.4nM)

ACCESSORIES:

Model SAS – Supply Air Sensor (Optional / Recommended for equipment protection).
Model CPLS – Coil Protection Lockout Switch (Freeze Stat / Optional / Recommended).
Model DAPC - Airflow and static pressure control (Optional / Recommended).

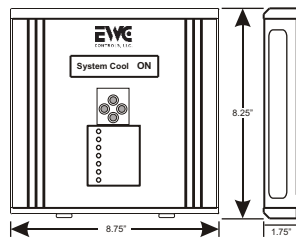

NOMINAL DIMENSIONS
9" X 9" X 2"

Typical Up-flow Installation with DX Cooling

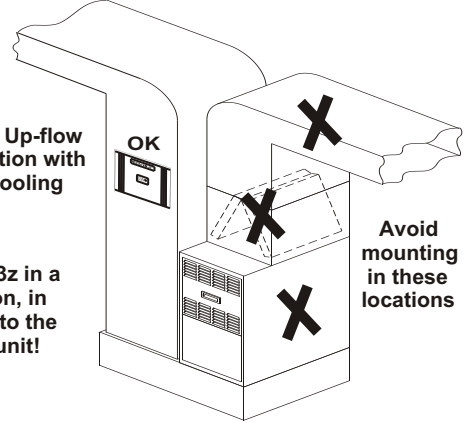

Install the NCM-3z in a suitable location, in close proximity to the HVAC indoor unit!

Avoid mounting in these locations

DEDICATED Power Supply

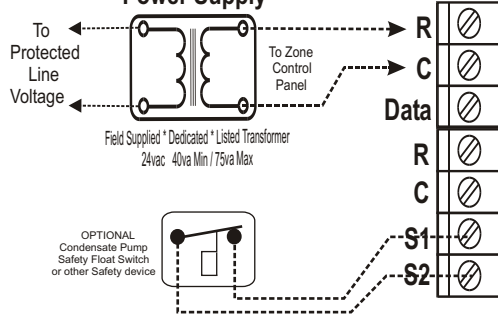

Install a dedicated Transformer to Power the NCM-3z!
Route the Data connection along with the spare R & C, to a DAPC Pressure Controller.
OR
Use the spare R & C terminals to power an SBD2 or EBD Bypass Damper.
Connect your dry contact "safety device" (wet switch, smoke detector, etc) to the S1/S2 circuit for equipment shutdown.



If desired, you can reset the NCM-3z back to factory settings!

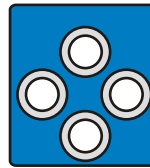

Upon Power Up, Press and Hold the Left & Right buttons to Load Factory Default Values, then Release.

TABLE 1 - Product Menu & Factory Default Settings

FEATURE	DEFAULT	RANGE TO SELECT
LCD Contrast	22	15 to 30
System Type	Heat/Cool	Heat Pump or Heat/Cool
T-Stat Type	Heat/Cool	Heat Pump O or Heat Pump B or Heat/Cool
Emergency	OFF	ON or OFF
Fan Mode	Gas	Gas or Hydro (Electric)
Hydro Fan Dly	N	Yes or No (Fan starts 45 seconds after W1)
W2 Timer	OFF	5, 15, 30, 45 or 60 minute delay
Gas Limit	145° F	120° to 180° F
HP Limit	120° F	110° to 135° F
Cool Limit	43° F	35° to 50° F
Purge w/Fan	N	Yes or No (Run Fan during Purge)
Purge Delay	90s	60, 90, 120, 150 or 180 seconds
S1 & S2 Purges	Purges	Purges or Stops
Fresh Air Opt	N	Yes or No (If Yes, additional input needed)
FA area 1200sqft	1800 sq ft	500 to 5000 sq ft (100ft increments)
FA Occupants 04	04	02 - 12 Occupants
FA Duct Size 6in	6in	4in - 8in FA Duct Size
NCM Code Rev	1.45	None (Code Version for Display Only)

LCD Screen Programming

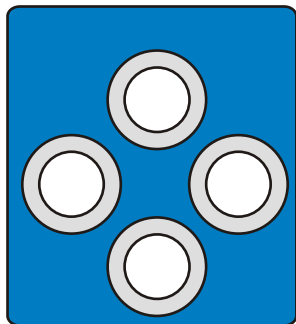

Use the *Left or Right* button to navigate and select Menu Features. Use the *Up & Down* buttons to change or adjust the options available in a particular feature. Select only the functions you want or need. ***For future reference, place a check mark next to each selection in the boxes below or write the selected value in the box.*** Your changes will take effect in real time and the NCM-3z will remember your settings even after a power failure.

4 Button LCD Programming

Step 1

Heat Pump System

OR

Heat Cool System

Select either **Heat Pump** or regular **Heat/Cool** system. If you have a hydronic (hot water) coil as the primary heat source, that is considered a Heat/Cool system.

Step 2

Heat / Cool 'Stats'

OR

HP STAT TYPE 'O'

OR

HP STAT TYPE 'B'

Select the type of thermostats you want to connect to the NCM-3z. "HP Stat" type O or B. or "Heat/Cool Stats".

** You can select Heat/Cool thermostats for any system type, even a Heat Pump system, but you cannot mix thermostat types! All zone thermostats must be wired/programmed for either HP or H/C.*

** Incorrect wiring or programming of the NCM-3z and/or the zone thermostats, could result in undesirable operation. Double check!*

Step 3

EMERGENCY OFF

OR

EMERGENCY ON

If you are using standard Heat/Cool thermostats and your Heat Pump fails, use this feature to enable "Emergency Mode". The NCM-3z will bypass the Heat Pump and operate the back-up heating system, when the zone thermostats call for heat.

This feature can still be used even if "HP Stat Type O or B" was selected in Step 2. Remember to set this feature back to OFF, after your Heat Pump is repaired and operational.

Step 4

Fan Mode GAS

OR

Fan Mode HYDRO

Select how you want the Indoor Fan to operate during Heating operations. Select GAS if you have a Gas or Oil Furnace with A/C. Select HYDRO if you have an Air-Handler with a Hot Water Coil or straight Electric (resistance) Heat.

Step 5

Hydro Fan Dly Y

If you selected HYDRO in step 5, then select Y for YES, to delay the indoor fan when a heating operation starts. Waiting 45 seconds to start the fan (after W1/B energizes) allows the Hydro coil a chance to heat up, before the air starts moving. If you have straight electric heat, select N for NO, and the indoor fan will energize immediately at the start of every heating call.

Step 6

W2 Timer 15m

If you have a single stage furnace with AC, leave this feature in the OFF position. Heat Pump systems with "HP Stats", do not need this feature either. Leave it OFF!

If you selected Heat/Cool 'Stats' in Step 2, and you have a Heat Pump or a 2 stage Furnace, then choose how many minutes of delay you want and the NCM-3z will control W2 (High Fire) or W2/E (Auxiliary Heat) for you.

The "W2 Timer" is OFF by default. If enabled, the selectable time delays are 5, 15, 30, 45 or 60 minutes.

Step 7

Gas Limit 145°

Set this value 8 - 10 degrees below the factory equipped high temperature limit on your furnace.

If the actual supply air temperature exceeds the selected "Gas Limit" value, the NCM-3z will cycle the furnace off-line for 4 minutes to avoid a lock-out condition on your furnace. The default value of 145°F, is good for most furnaces. The adjustable Gas Limit range is 120°F to 180°F. ***Continued on next page...***

LCD Screen Programming

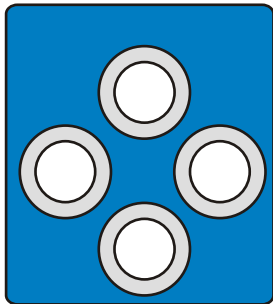

Use the *Left* or *Right* button to navigate and select Menu Features. Use the *Up* & *Down* buttons to change or adjust the options available in that feature. Select only the functions you want or need. ***For future reference, place a check mark next to each selection in the boxes below or write the selected value in the box.*** Your changes will take effect in real time and the NCM-3z will remember your settings even after a power failure.

4 Button LCD Programming

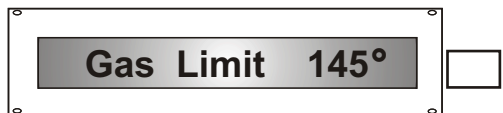

Step 7

GAS LIMIT CONTINUED FROM PAGE 4...

When 4 minutes expires, the NCM-3z will resume normal heating operations in low fire (W1). If the “W2 Timer” is being utilized and the supply air temperature got to hot (*before or while*) W2/E was energized, the W2 Timer will reset. Now the W2 Timer must “time out” again, before the NCM-3z will energize W2/E.

NOTE: *All zone dampers will be forced open, during the 4 minute period, in order to rapidly dissipate heat. The dampers will go back to their intended positions after 4 minutes expires and the duct temperature drops.*

NOTE: *Excessive short cycling on the Gas Limit, may indicate a dirty air filter, a faulty zone damper, unbalanced bypass duct and/or under-sized duct-work.*

NOTE: *On HP applications, the NCM-3z references the Gas Limit set-point (rather than the HP Limit set-point) **only** when W2/E energizes the auxiliary strip heat. This logic assumes the Supply Air Sensor is installed in the Supply Plenum (after the strip heat) rather than “inside” the Air Handler’s blower section (before the strip heat). If the sensor is installed “inside” the Air Handler, set the “Gas Limit” down to 125°F, to match the HP Limit.*



Step 8

Set this value to a temperature that correlates to a condensing pressure, that will avoid a high head pressure condition during HP heating operations.

If the supply air temperature exceeds the selected “HP Limit” value, the NCM-3z will cycle the HP off-line for 4 minutes to avoid tripping the high head pressure control on your HP. After 4 minutes expires the NCM-3z will resume HP heating operations. If the “W2 Timer” is being utilized and the supply air temperature got to hot (*before or while*) W2/E was energized, the W2 Timer will reset. Now the W2 Timer must “time out” again before the NCM-3z will energize W2/E. *Continued on upper right...*



Step 8

HP LIMIT CONTINUED FROM LOWER LEFT...

The default value of 120°F, is good for most Heat Pumps running R410A refrigerant. You may want to reference your Temp/Pressure chart and select a different value and/or a different refrigerant type. The adjustable HP Limit range is 110°F to 140°F.

NOTE: *All zone dampers will be forced open, during the 4 minute period, in order to rapidly dissipate heat. The dampers will go back to their intended positions after 4 minutes expires and the supply air temperature drops.*

NOTE: *Excessive short cycling on the HP Limit, may indicate a dirty air filter, a faulty zone damper, unbalanced bypass duct and/or under-sized duct-work, or refrigerant over-charge.*

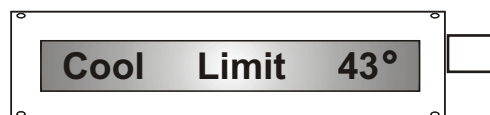

Step 9

The recommended Cool Limit set-point is 43°F, to avoid a coil freeze-up. Although you may need to set this value slightly lower to accommodate “Dehumidify” operations. Resist the urge to adjust the Cool Limit *lower* than 38°F.

If the actual supply air temperature exceeds the selected “Cool Limit” value, the NCM-3z will cycle the Condensing unit off-line for 4 minutes. When 4 minutes expires and the supply air temperature moderates, the NCM-3z will resume normal cooling operations.

NOTE: *All zone dampers will be forced open, during the 4 minute period, in order to rapidly warm up the coil. The dampers will go back to their intended positions after 4 minutes expires and the supply air temperature rises above the Cool Limit set-point.*

NOTE: *Excessive short cycling on the Cool Limit, may indicate a dirty air filter, a faulty (closed) zone damper, unbalanced bypass duct and/or under-sized duct-work, or a low refrigerant charge.*

NOTE: *Resist the urge to keep lowering the Cool Limit set-point, to avoid short cycling! Look for the root cause of “Why is the supply air too cold?” and fix it! Continued lowering of the Cool Limit set-point is not recommended.*

LCD Screen Programming

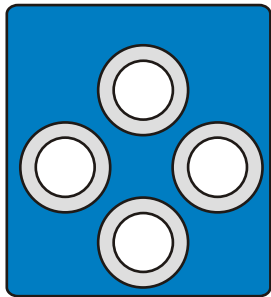

Use the *Left or Right* button to navigate and select Menu Features. Use the *Up & Down* buttons to change or adjust the options available in that feature. Select only the functions you want or need. ***For future reference, place a check mark next to each selection in the boxes below or write the selected value in the box.*** Your changes will take effect in real time and the NCM-3z will remember your settings even after a power failure.

4 Button LCD Programming



Step 10

The NCM-3z can force the Indoor Fan to run (during the Purge Delay) at the end of heat and cool demands.

The Purge Delay is described below in Step 11.

If you don't need this feature, select N for NO, which is the factory default setting. Select Y for YES, if you want the Indoor Fan to run during the Purge Delay.

Hydronic (Hot Water) systems will benefit from this feature because the Hydronic coil is holding a lot of residual heat after the water stops flowing.

If set to YES, the NCM-3z will force the indoor fan to run during the Purge Delay. If set to NO, the Purge Delay will still occur, but the NCM-3z will not force the fan to run during the Purge Delay.



Step 11

The "Purge Delay" occurs at the end of every Heating or Cooling operation. The Purge Delay cannot be disabled, but you can select how long the delay occurs. Purge Delay is adjustable from 60, 90, 120, 150 or 180 seconds. The factory default is 90 seconds.

When the last zone is satisfied, the NCM-3z will hold that zone's damper in the Open position (*all others remain closed*) so the remaining hot or cold air, flows into the last zone that needed it and not the others. NOTE: The Purge delay times out concurrently with the fixed 4 minute Short Cycle delay. *ie, A purge delay of 60seconds results in a 3 minute short cycle delay. A purge delay of 90seconds, results in a 2.5 minute short cycle delay. A purge delay of 180seconds results in a 1 minute short cycle delay.*

After the Purge Delay expires, the NCM-3z will open all dampers and enter "short cycle delay" **or** "change-over delay", if active zone demands are detected. If no additional zone demands are detected, the NCM-3z will enter "idle mode" until zone demands are detected.

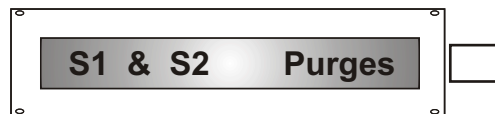

Step 12

OR

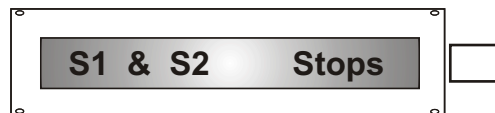

The NCM-3z safety circuit allows you to connect (interlock) safety devices directly to the NCM-3z. If the safety device contacts open, the NCM-3z will shut-down in the mode that you select above. **NOTE: The S1/S2 jumper link must be cut in order to monitor a safety device!** See page 8 for details.

If the Safety Device contacts open:

PURGES mode forces ALL connected zone dampers to the full "open" position and runs the Indoor Fan only! Heating and Cooling demands are no longer honored until the Safety device contacts close.

PURGES mode should be selected for Emergency pan wet switches or condensate pump/trap over-flow switches. This feature could also be used for A2L refrigerant leak detectors, that major OEM's may release in the near future.

STOPS mode forces ALL connected zone dampers to the full "close" position and stops the Indoor fan! Heating, Cooling & Fan demands are no longer honored until the Safety device contacts close.

STOPS mode should be selected for smoke detectors or fire alarm panels. Stopping the fan and closing the zone dampers may reduce smoke migration via the duct-work. **Warning:** Residential zone dampers are not fire/smoke rated. No claims, specifications or guarantees of fire/smoke ratings are made herein.

LCD Screen Notification:

If an interlocked safety device activates, the NCM-3z LCD screen will notify you by displaying S1/S2 Lockout!

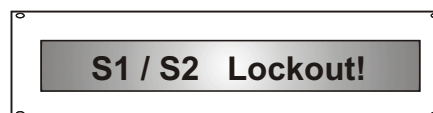

When the safety device contacts re-close, the "lockout" screen shown above will go away, and the NCM-3z will resume HVAC operations after a 4 minute delay expires.

See page 10 for details on connecting safety devices!

LCD Screen Programming

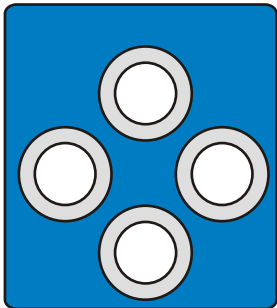

Use the *Left* or *Right* button to navigate and select Menu Features. Use the *Up & Down* buttons to change or adjust the options available in that feature. Select only the functions you want or need. ***For future reference, place a check mark next to each selection in the boxes below or write the selected value in the box.*** Your changes will take effect in real time and the NCM-3z will remember your settings even after a power failure.

4 Button LCD Programming



Step 13

On two zone applications, the spare Zone #3 may be used to control a Fresh Air damper. The NCM-3z will calculate “Minutes of Fresh Air per Hour” for you, based on the variables you set, as described on this page.

Select N for NO, if you do not want or need this feature.

Select Y for YES to activate this feature and use Zone 3 to operate a Fresh Air (FA) damper.

NOTE: You must install a dedicated Outside Air damper (24vac motorized) and route the OA duct to the return air plenum of the HVAC system. Make sure the Outside Air “passes through” the HVAC system’s primary air filter or provide a dedicated Outside Air filter.

NOTE: DO NOT locate the OA intake within 3 ft of any appliance vent/exhaust or sewer vent pipe. Provide an insect/rodent/bird screen on the outside air duct intake. **Follow local and/or national mechanical code.**

NOTE: The “Minutes of Fresh Air/Hour” calculated by the NCM-3z, does not credit for “other means” of Fresh Air coming into the building such as an ERV/HRV, open windows/doors or natural infiltration. **You may reduce the “Minutes of FA/Hr” to your liking, if you disagree with the FA cycle time calculated by the NCM-3z.**

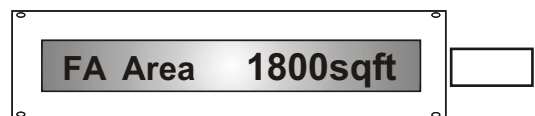

Step 14

If you selected Y for Yes on Step 13, this screen will appear next in the menu.

Set the Square Footage of the home on this screen by pressing the up or down buttons! Each press of the button adjusts the square footage 100sqft at a time.

The adjustable range is 500sq ft to 5000 sq ft and the default is 1800sq ft.

You may round up or down to get as close to the actual square footage as you can.

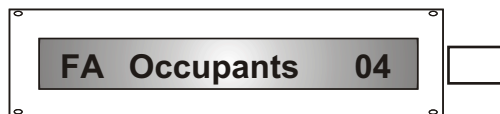

Step 15

If you selected Y for Yes in Step 13, this screen will appear after step 14.

Set the total number of people living in (occupying) the home on this screen. The default number of occupants is 4 people. The adjustable range is 2 to 12 people.

NOTE: Do not include persons who are staying in the home for a short time period. ie weekend visitors.

NOTE: Pets are optional and may be included if desired.



Step 16

If you selected Y for Yes in Step 13, this screen will appear after step 15.

Select the size (diameter) of your Outside Air duct. Most residential/light commercial OA duct is round “steel” duct.

The default diameter is 6” (6in). The adjustable range is from 4” diameter up to 8” diameter.

NOTE: If your OA duct is rectangular, use a duct calculator to determine the equivalent diameter and select that size. ie 9” x 6” duct = 8” diameter round duct.

NOTE: Larger diameter OA duct will result in fewer FA minutes/hour, because the larger duct can move more air than smaller diameter duct.

Once you have selected the parameters for Fresh Air cycling, the NCM-3z will calculate the “Minutes of Fresh Air/Hour” required, in order to properly ventilate your home with outside air. Example below is 35 minutes per hour.



NOTE: The NCM-3z will always attempt to achieve the required minutes of FA/Hr by opening the OA damper during heating and cooling operations. This will reduce the impact of introducing cold or hot air into the home.

If the NCM-3z does not detect a sufficient quantity of heat or cool demands (in a given hour) in which to open the FA damper, the NCM-3z will force a FA cycle (at the end of the hour), to satisfy the number of FA minutes remaining.

LCD System Messages

Once the programming is complete the LCD screen will scroll continuously (non-stop) displaying the HVAC system mode of operation at any particular time. Other information is also displayed including real time Supply Air temperature or the system static pressure if a DAPC is connected to the NCM-3z. By watching the LCD display you can observe all system functions as they occur. If desired, you can navigate to a single screen by pushing the Up or Down button, until you see the screen you are interested in. Each zone's thermostat demands can be observed as well as the data screens mentioned below. ie **Z1 Heat Demand, Z2 Idle, Z3 Cool Demand, Z2 Emergency DMD, Z1 Auxiliary DMD**, etc. *Below are typical LCD data screen examples:*



This screen is displayed when there are no active demands from any zone thermostats. Although idle, the Supply Air temperature is displayed as well.

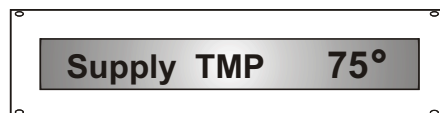

A Supply Air Sensor (#SAS) is a standard accessory and is included with the NCM-3z. When properly installed and wired, the NCM-3z will display the supply air temperature of the HVAC system during all modes of operation (Cool, Heat, Purge, Fan & Idle).

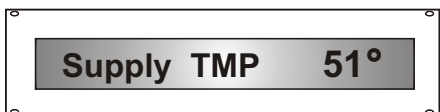

In addition to other data, the two screens above are displayed during a cooling operation, the NCM-3z will toggle the LCD screen to show both the system mode of operation (Cooling) and the real time Supply Air temperature. *See page 7.*

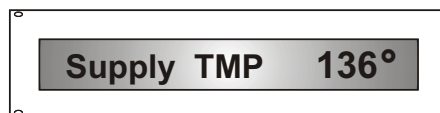
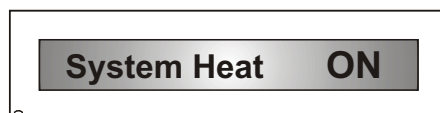

In addition to other data, the two screens above are displayed during a heating operation. The NCM-3z will toggle the LCD screen to show both the system mode of operation (Heating) and the real time Supply Air temperature.

Examples of "other data" are S1/S2 lock-out condition, Fresh Air and Supply air sensor events. *See page 6 & 7.*

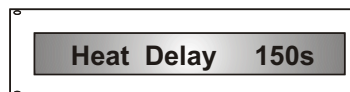
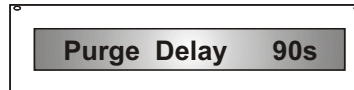

The Purge Delay screen above is displayed at the end of a cooling or heating operation. The Timer is also displayed as it counts down to zero to complete the Purge cycle.

If the NCM-3z detected consecutive Heat or Cool demands (short cycle) condition, the NCM-3z will display the Timer count-down for that mode of operation as well.

The NCM-3z holds the last active zone damper(s) open, while the other (inactive) zone dampers remain closed, allowing the final hot or cold air to purge/flow into the last active zone. The duration of the "Purge Delay" is adjustable, 60, 90, 120, 150 or 180 seconds.

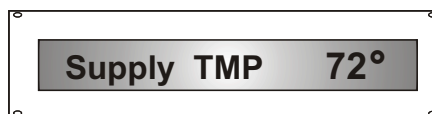
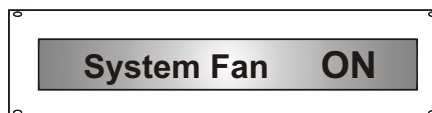

The two screens above are displayed during a Fan Only operation, the NCM-3z will toggle the LCD screen to show both the system mode of operation (Fan) and the real time Supply Air temperature.

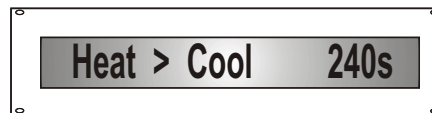

The NCM-3z will display one of the screens above, depending on whether the change-over is from Cool to Heat (CH) or from Heat to Cool (HC). This example display is your indication that "Opposing Demands" from the zone thermostats are occurring. The change-over count-down is also displayed. The NCM-3z will toggle the LCD screen to show the real time Supply Air temperature as well.

LCD System Messages

A Supply Air temperature sensor (P# SAS) may or may not be included with the NCM-3z. If the SAS is included, EWC highly recommends that the sensor be installed. If the sensor is not installed the NCM-3z will still operate the HVAC system normally. If the sensor is installed and the actual supply air temperature exceeds the active heating or cooling supply air temperature limit value, the NCM-3z will cycle the HVAC system off-line for 4 minutes. If the installed sensor becomes disconnected or shorts out, the NCM-3z will continue operating the HVAC system normally. However, the NCM-3z will provide a warning on the LCD, that the supply air sensor is in fault mode and requires attention. *LCD screen examples, showing supply air monitoring notifications are shown below.*

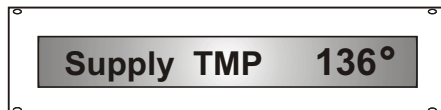

A Supply Air Sensor (#SAS) may or may not be included with the NCM-3z. When properly installed and wired, the NCM-3z will display the real time supply air temperature of the HVAC system during all modes of operation (Heat, Cool, Fan & Idle).

If the supply air sensor is installed but then becomes disconnected, or the sensor fails (shorted/open) the the LCD screen will display the warning message shown below.

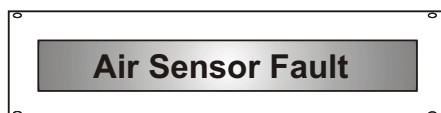

Heating & Cooling demands are still honored, but the NCM-3z cannot cycle the HVAC system off-line, if supply air temperature limits are exceeded.

If the supply air sensor is properly connected and the actual supply air temperature exceeds the active heating supply air temperature limit, the NCM-3z will cycle the HVAC system off-line for 4 minutes and display two warning messages.

Note: OTC = "Over Temperature Condition".



The 4 minute delay must count down to zero before Heating is allowed to re-energize.



After 4 minutes has expired and the actual supply air temperature has dropped below the active heating supply air temperature limit, the NCM-3z will resume heating operations.

NOTE: Even if the supply air temperature moderates quickly (less than 4 minutes) the 4 minute delay must expire, before the NCM-3z will resume heating operations.

If the supply air sensor is properly connected and the actual supply air temperature exceeds the active cooling supply air temperature limit, the NCM-3z will cycle the HVAC system off-line for 4 minutes and display two warning messages.

Note: UTC = "Under Temperature Condition".

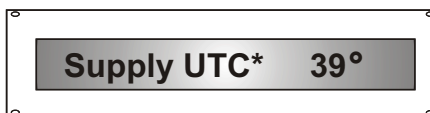

The 4 minute delay must count down to zero before Cooling is allowed to re-energize.



After 4 minutes has expired and the actual supply air temperature rises above the active cooling supply air temperature limit, the NCM-3z will resume cooling operations.

NOTE: Even if the supply air temperature moderates quickly (less than 4 minutes) the 4 minute delay must expire, before the NCM-3z will resume cooling operations.

LOCATION: The supply air sensor is typically mounted in the supply air plenum on Gas, Oil, Hydronic or Straight Electric heating systems. The sensor can be mounted as close as necessary to the heat exchanger (within 12") because it can with-stand temperatures greater than the HVAC system can produce.

On Heat Pump systems with an Air Handler and integrated evaporator coil on the negative side of the indoor fan, you have the option to install the sensor in the blower area.

Remove the sensor from the aluminum tubing and secure the sensor inside the Air Handler blower section, near the DX (evaporator) coil. The sensor is now "hanging" directly in the conditioned return air stream, and will protect the Heat Pump during cooling and heating mode, but remains unaffected by the electric strip heat. **NOTE:** Set the "Gas Limit" to 120° F if you install the sensor in the Air Handler's blower section.

Temperature variations (dead spots) do occur in the supply plenum, so selecting a good location is important:

* Use the genuine Ultra-Zone sensor (P# SAS), included in the box. Do Not use other brand sensors or thermistors.

* Install the sensor in the supply plenum, as close to the mid-air stream as possible, upstream (before) any zone dampers, secondary trunks or branch runs.

* Do Not install the supply air sensor in the bypass duct or return duct.

* Avoid splicing the SAS field wiring and creating additional resistance, which will affect temperature accuracy.

Built-In Time Delay Settings

To avoid redundant or doubling of time delay functions, it may be best to disable each Thermostat's "short cycle" delay.

The NCM-3z Time Delays will protect the HVAC system from short cycling.



Momentarily pressing the RIGHT & LEFT buttons clears the built-in timers controlling the Start-up timer, Minimum run timer, Short cycle timer, W2 timer, Supply air sensor timer and the Changeover timer. This enables you to test the installation faster.

Caution should be observed when using this button.

The NCM-3z has built-in Time Delay events to insure safe HVAC system operation!

- * Start-up Delay = 3 minutes, Fixed.
- * Short Cycle Delay = 4 minutes, Fixed.
- * Changeover Delay = 4 minutes, Fixed.
- * Purge Delay = 60, 90, 120, 150 or 180 seconds.
- * Supply Air Limit Delay = 4 minutes, Fixed.
- * S1 / S2 Safety Delay = 4 minutes, Fixed.
- * Opposing Demand Timer = 20 minutes, Fixed.

Time Delay Definitions

Start-up Delay Upon initial power-up or after a power failure, the NCM-3z will not start or resume operations for 3 minutes.

Short Cycle Delay After all zones are satisfied, the NCM-3z will not re-start the same mode of operation (heating or cooling) for a minimum of 4 minutes. Note: The (default) 90 second Purge Delay runs concurrently (within) the 4 minute Short Cycle delay.

Change-Over Delay In the event opposing zone thermostat demands occur (heat vs cool or cool vs heat) and the NCM-3z terminates the current mode of operation (heating or cooling), a 5.5 minute delay must expire before the NCM-3z will switch to the opposite mode of system operation. **NOTE:** The (default) 90 second Purge Delay does not run concurrently with the Change-Over delay. These two delays run separately.

Purge Delay At the end of any cooling or heating operation, the NCM-3z will hold the "last to call" damper(s) in the open position (all others remain closed) for the time you select. 60, 90, 120, 150 or 180 seconds.

Supply Air Limit Delay If the NCM-3z detects that supply air temperature has exceeded the selected supply air temperature limit, it will cycle the HVAC system off-line. The NCM-3z will not resume HVAC operations until the supply air temperature has moderated and 4 minutes has expired. **See page 5.**

Opposing Demand Timer A 20 minute delay (starts on every Heat/Cool function) must expire, or the active zone(s) must satisfy, before the NCM-3z will honor a zone demand to "changeover" to the opposite mode of system operation.

S1 / S2 Safety Delay If the S1/S2 circuit opens, the NCM-3z will stop all Heating & Cooling operations. When the S1/S2 circuit closes again, the NCM-3z will resume Heating & Cooling operations in 4 minutes. **See page 6 & 10.**

LINKS
S1 - S2

S1/S2 Safety Circuit Details

* The S1/S2 jumper link (at bottom left corner) must be cut in order to monitor a safety device. If the S1/S2 link is not cut, the NCM-3z cannot detect when the safety device opens the circuit.

* The safety device must have normally closed (fail open) dry contacts!

* **NOTE:** If S1/S2 link is cut by accident, place a jumper wire across S1/S2 terminals.

Figure 3

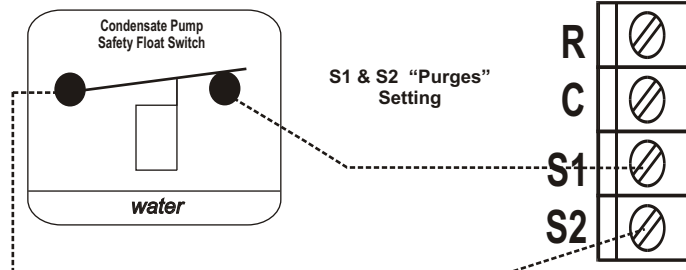

Connect the overflow safety circuit of your condensate pump to the S1/S2 terminals of the NCM-3z. So long as the float switch contacts remain closed, the NCM-3z will operate the HVAC system. If the contacts open, the NCM-3z will open all dampers and run the fan. **NOTE:** The S1/S2 link must be cut!

Figure 4

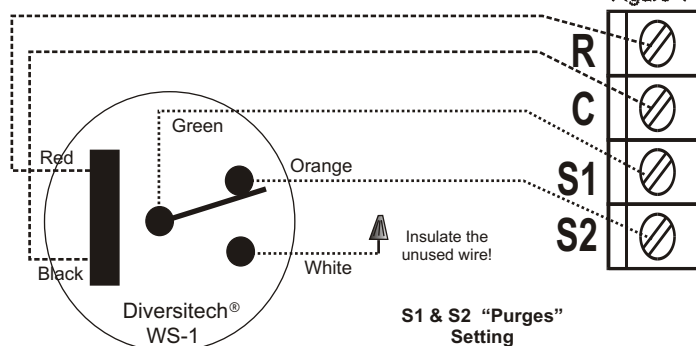

Connect 24vac and S1/S2 terminals to the Emergency "overflow" pan switch as shown. So long as the emergency pan switch contacts remain closed, the NCM-3z will operate the HVAC system. If the contacts open, the NCM-3z will open all dampers and run the fan. **NOTE:** The S1/S2 link must be cut!

Figure 5

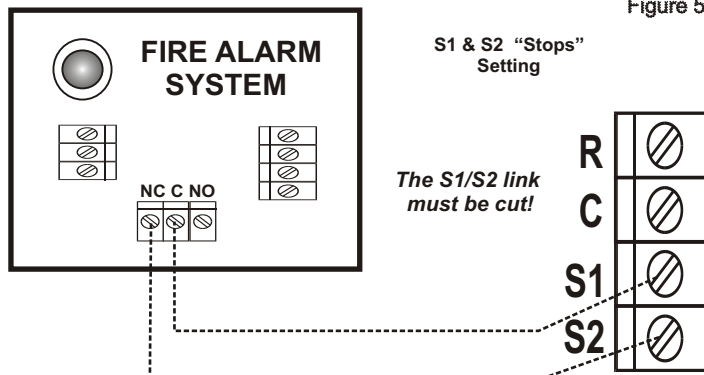

Ask the Fire Alarm Technician to connect your S1/S2 wires to a normally closed (NC) "dry contact" in the Fire Alarm panel. **Note:** The Tech will not let you connect them and if he does allow you, you should decline due to liability.

Confirm with the Technician that the dry contact will "OPEN" when the Fire Alarm system goes into "Alarm Mode". Test the circuit and confirm that the NCM-3z shuts down the HVAC system, including the Fan. All directly connected zone dampers should stroke to the "closed" position, to reduce smoke migration. The NCM-3z will not resume HVAC operations until the Fire Alarm panel is reset, and the S1/S2 circuit closes. **Warning:** Residential zone dampers are not fire/smoke rated. No claims/guarantees of such are made herein.

3 Zone Heat/Cool Application

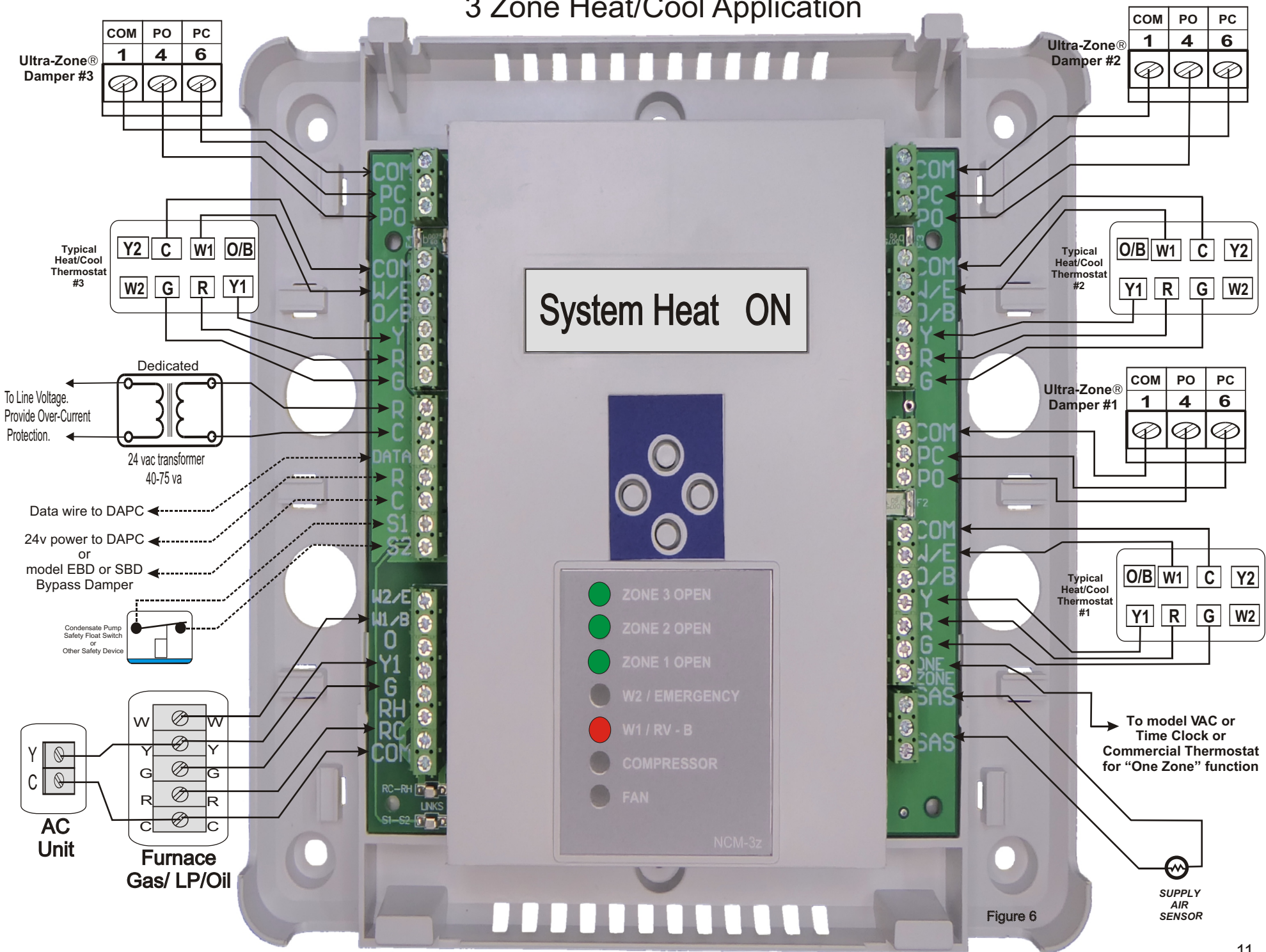

Figure 6

Thermostat Wiring

The NCM-3z is easy to understand and wire up. We have provided several examples of Thermostat wiring (and System wiring) on this page and the following pages for your consideration and review.

Since thermostat terminal designation and function varies, depending on the manufacturer, your actual field wiring may differ.

Remember that wire color is important but does not guarantee function! Wiring terminal to terminal (designation to designation) usually works best, regardless of the wire color. *ie, W = W1 and is usually a white wire but it could be a different color. Don't make assumptions!*

POWER WIRING

A dedicated (field supplied) 24vac, UL listed Transformer MUST be installed!
This transformer will power the NCM-3z, all Zone Thermostats, all Zone Dampers and one Accessory connected to the NCM-3z.

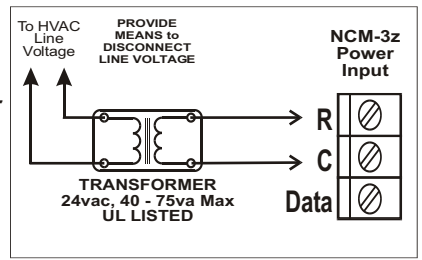

DO NOT rob 24vac power from the HVAC system, to power the NCM-3z!

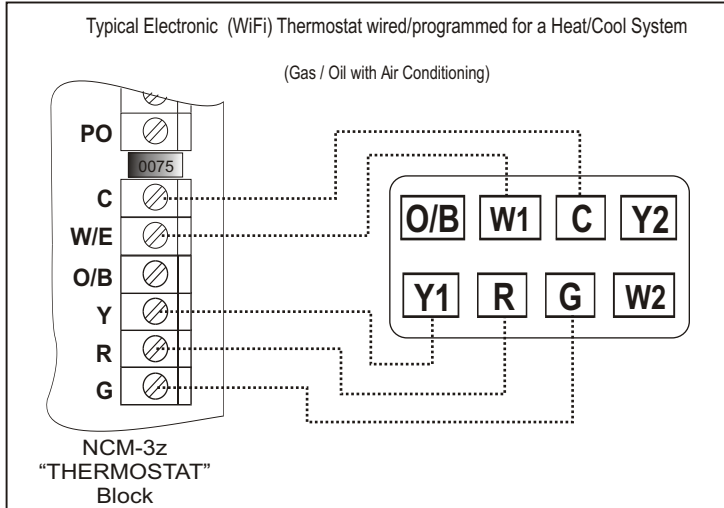

Figure 7 The diagram above reflects a "hard wired" thermostat. That means the thermostat will not function unless the 24v common wire is connected. Most WiFi and Home Automation thermostats require the 24v common wire. See Notes below!

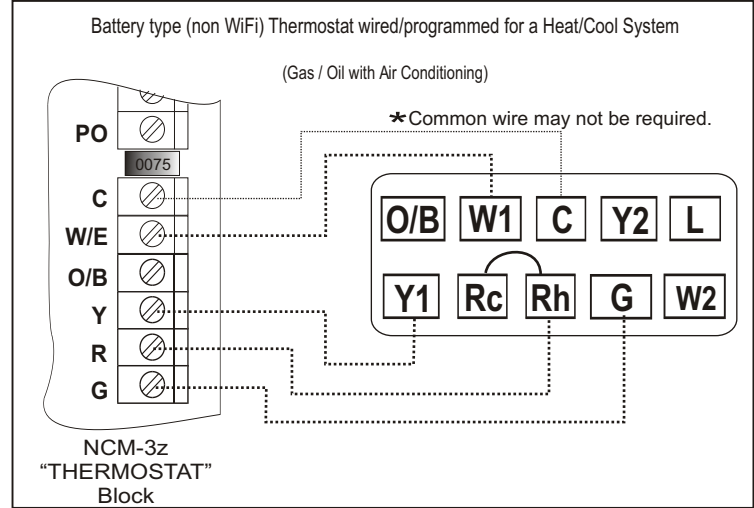

Figure 9 The diagram above reflects a "Battery" or "Power Robbing" thermostat, which means the thermostat only needs four wires. If you have five wires and the thermostat has a C terminal, make use of it and connect the 24v common wire anyway. See Notes below!

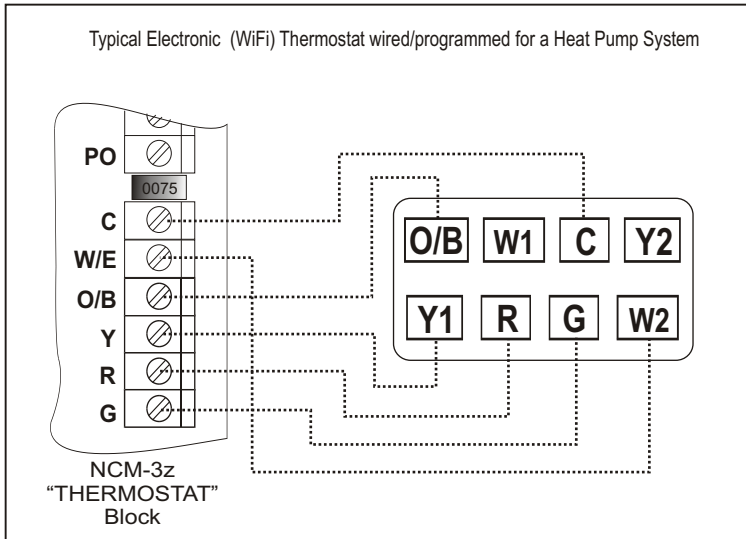

Figure 8 WiFi Heat Pump Thermostat wired/programmed for 2 heat & 1 cool. Your specific HP Thermostat wiring may differ. You must program the thermostat to match the Reversing Valve logic (O or B) of your Heat Pump.

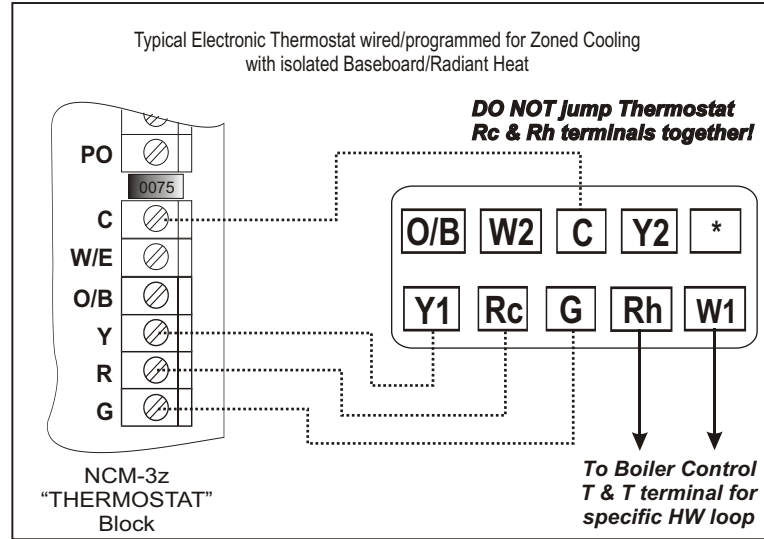

Figure 10 Electronic thermostat configured for Zone Air Cooling with separate Hot Water loop heating. Baseboard or Radiant (in floor) hot water heating loop.

NOTE 1: The NCM-3z is compatible with most 24vac (non-communicating) thermostats on the market. Hard Wired thermostats are preferred assuming you have a sufficient number of wires available. See Note 2 below.

NOTE 2: In the event you need a 24v "common" wire and are short by just one wire, you can use the "G" wire for the 24v common and eliminate the "G" circuit. *This is a simple/preferred solution versus using an expensive "Power Adapter" (that may or may not work) to achieve the 24v "common" connection to a Hard wired (WiFi) thermostat.* See Note 3 below.

NOTE 3: The NCM-3z does not need to receive a "G" signal from the thermostat, in order to operate the HVAC system in Cooling or Heating mode. What you give up is the ability to request "Fan Only" from that zone. Cooling, Heating and HP operations will still function properly. *Contact EWC Tech Support if you have questions on this solution.* See Note 4 below.

NOTE 4: EWC highly recommends that you disable the anti-short cycle compressor delay in all zone thermostats. The NCM-3z "built-in" time delays will protect the equipment and you will avoid the possibility of time delays stacking, and/or adversely affecting the NCM-3z sequence of operation.

System Wiring

WARNING: The NCM-3z zone control is designed for use with 24vac only! Do not use other voltages!

Use caution to avoid electric shock and/or equipment damage to this product or the HVAC system. All work should be performed by a qualified technician, to National/Local codes and ordinances. Use 18awg solid copper, color-coded, multi-conductor cable. Plenum rated where applicable. Shielded cable is not required.

Single Stage Gas/Electric System

Typical gas/electric system wiring for a single stage furnace with AC. It's not required but if you have enough wires, connect the 24v "C" wire as shown below.

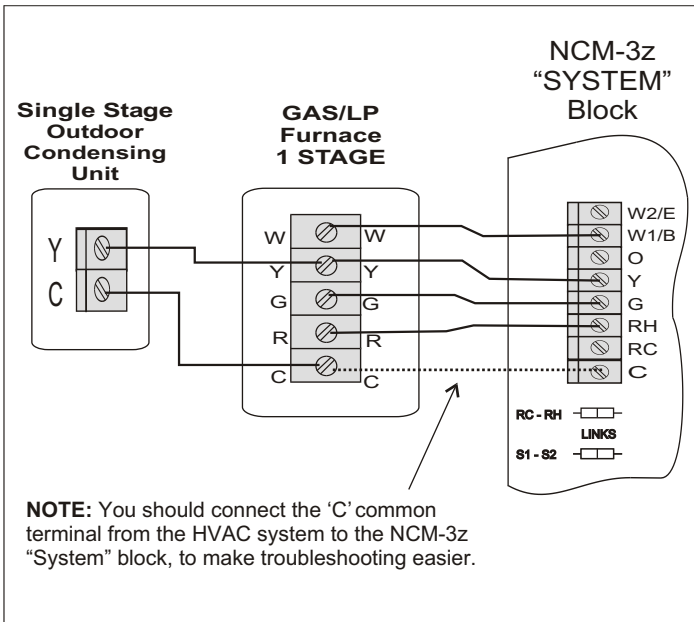

Figure 11

Heat Pump with "O" type Reversing Valve logic

Typical heat pump system wiring with electric resistance backup heat. Wire the HP reversing valve to the "O" terminal on the system block.

Read the "Important Note" below!

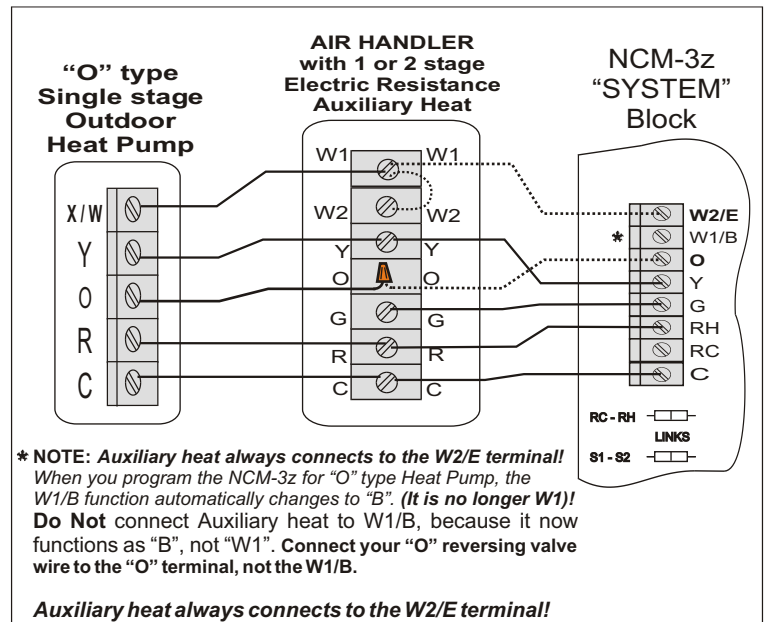

Figure 13

Two Stage Gas/Electric System

Typical gas/electric system wiring for a two stage furnace with AC. The NCM-3z will control W2 (high fire) not the Zone thermostats.

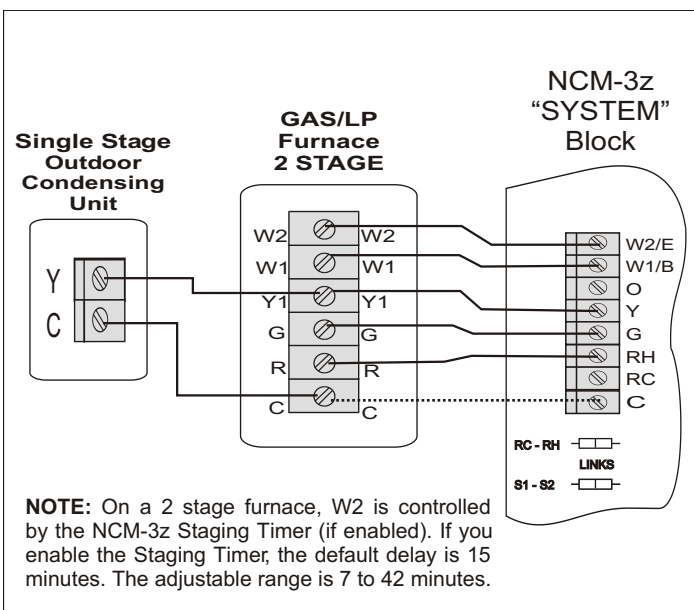

Figure 12

Heat Pump with "B" type Reversing Valve logic

Typical heat pump system wiring with electric resistance backup heat. Wire the HP reversing valve to the "W1/B" terminal on the system block.

Read the "Important Note" below!

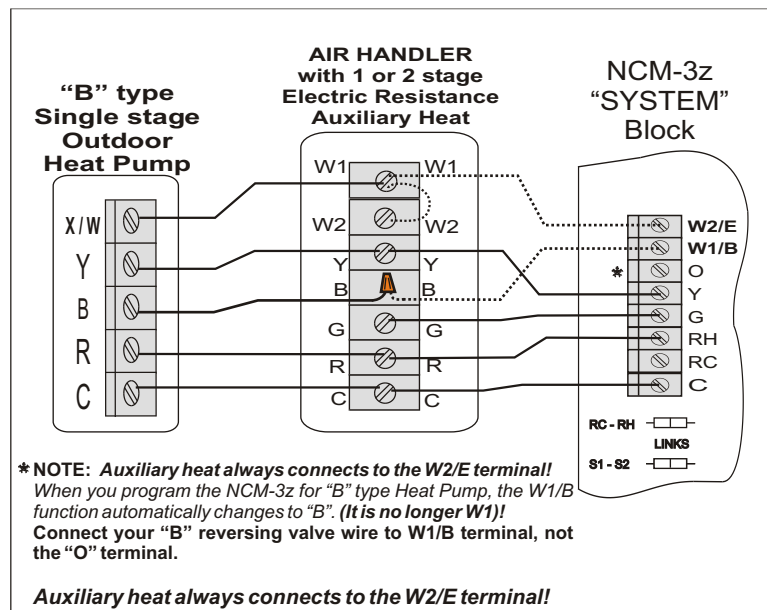

Figure 14

System Wiring

Two Transformer Hydronic Heating Systems

The NCM-3z Zone Control is Hydronic (Hot Water) heat friendly, due to the Rc/Rh “system” isolation circuit and there’s no need to install an Aqua-Stat. But wiring these systems can be challenging because you are introducing a foreign 24v source (T&T from the Boiler) into the Air Handler and into the Zone Controller. **This foreign voltage must remain isolated from the 24v source in the Air Handler!**

Old Tech Air Handlers with Permanent Split Capacitor (PSC) motors provide the proper CFM when only the “G” fan circuit is energized. These older inefficient Air Handlers don’t need to detect the “W” heating signal, so you can use the NCM-3z Rc/Rh isolation feature.

* Figure 15 is for old tech PSC motor types. Cut the Rc/Rh link (to isolate) and connect the Boiler T&T circuit straight to the Rh and W1/B.

New Tech Air Handlers with Variable Speed motors (ECM High Efficiency) will not provide the proper heating CFM, unless the VSP circuit board detects the “W” heating signal. The “G” fan circuit runs at low speed only, so you cannot use the NCM-3z Rc/Rh isolation feature.

* Figure 16 is for new tech VSP/ECM motor types. The isolation relay is required (cannot use the Rc/Rh isolation) because the VSP motor must detect the W signal from the Air Handler’s 24v power, not the Boiler’s 24v power.

* Figure 17 pertains to First Company® Air Handlers only. This OEM provides the isolation circuit for you. There’s no need for a field relay.

* Figure 18 is for Heat Pump applications where the Hydronic coil is the auxiliary heat source. The isolation relay is required (cannot use the Rc/Rh isolation) because the reversing valve must detect the O/B signal from the Air Handler’s 24v power, not the Boiler’s 24v power.

* If you’re unsure of the motor type in your Air Handler, use an isolation relay! (Figure 16 or 18) depending on HC or HP application.

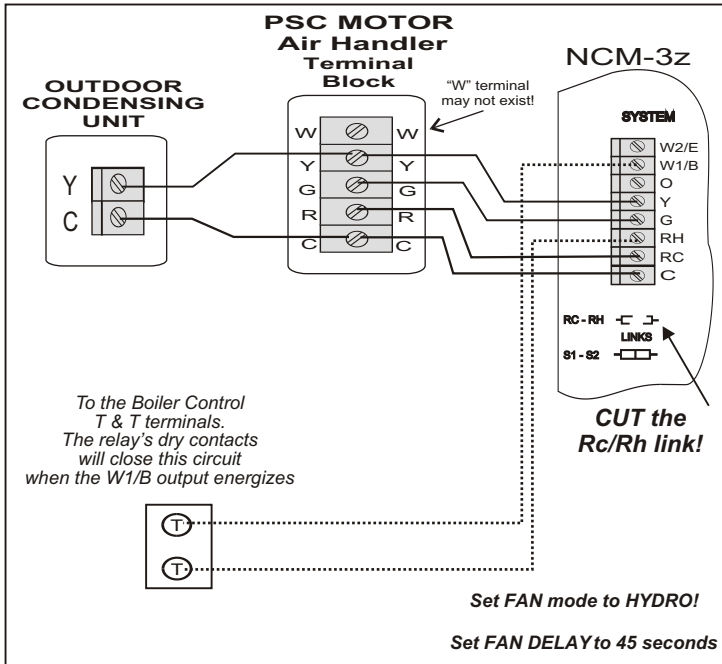

Figure 15

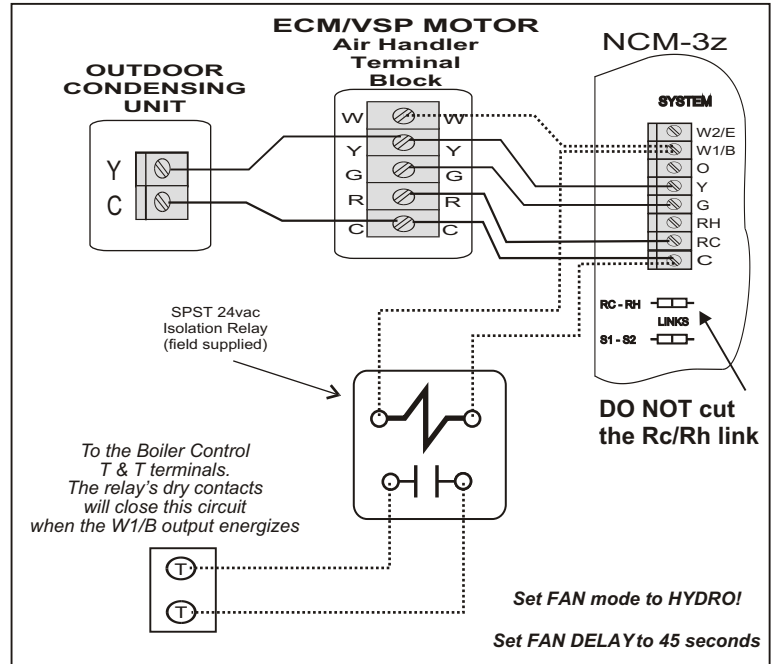

Figure 16

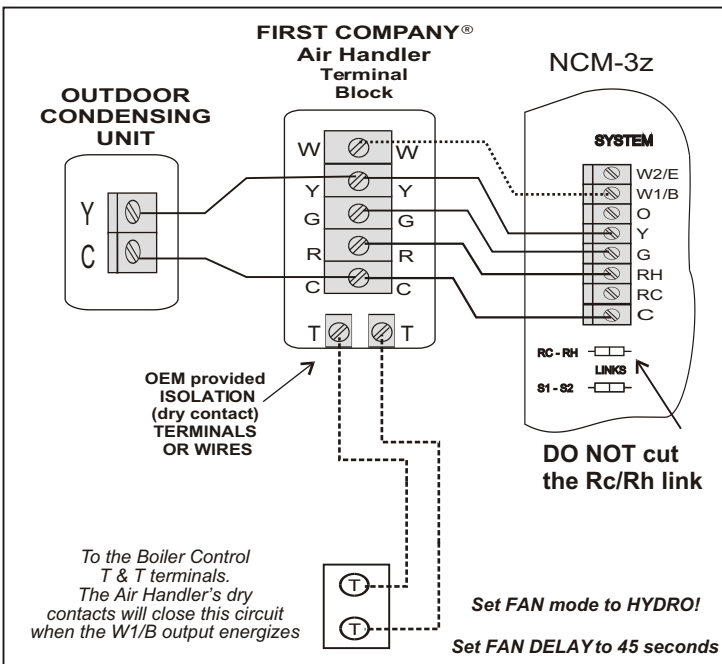

Figure 17

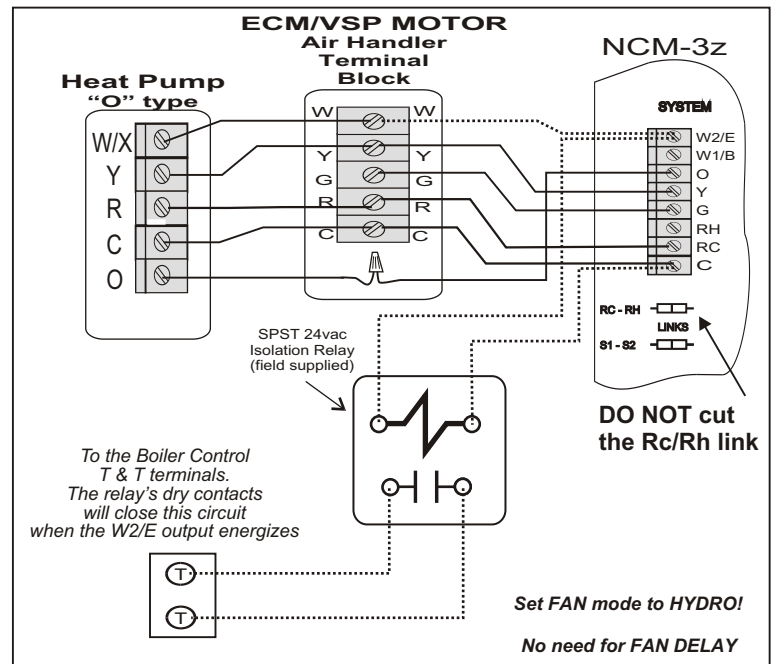

Figure 18

DAMPER WIRING

Note: Each zone (Damper and Thermostat) is protected by a 750mA Auto-Reset Circuit Breaker. This breaker may trip if too many dampers are connected to a single zone and the NCM-3z is located in a very warm or hot location such as an attic.

* You can safely connect up to five (5) Model ND, URD, or SID dampers **per zone** (plus a WiFi thermostat) without tripping the 750mA breaker.

* The total number of dampers allowed (across all zones) depends on damper motor current draw, thermostat current draw and the ambient temperature where the NCM-3z is located. See page 2 specifications.

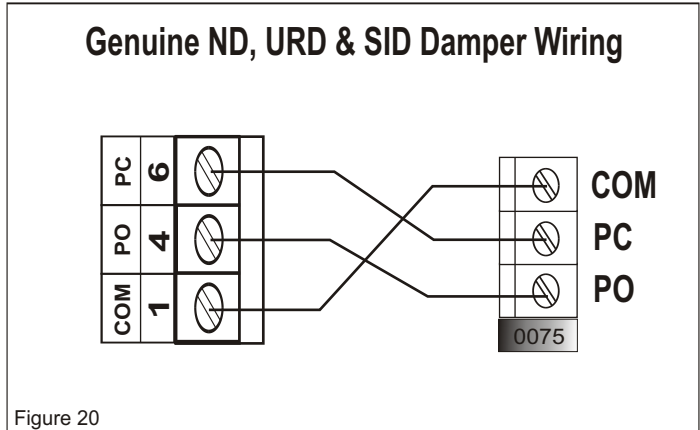
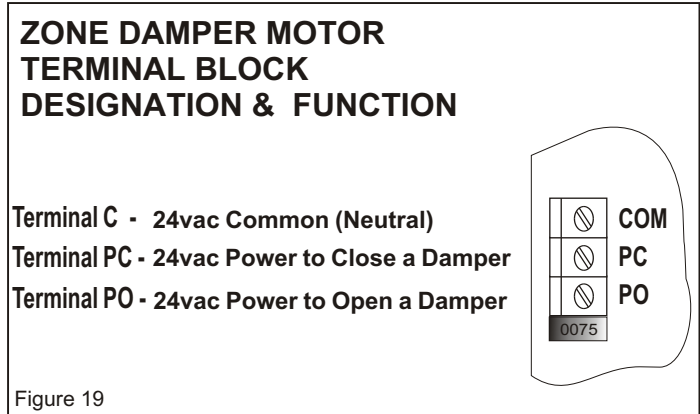

PARALLEL versus SERIES wiring

Resist the urge to wire dampers in series, jumping from motor to motor. Wiring multiple motors in parallel (as shown below) reduces the possibility of loose connections and voltage drop.

Three or More ND, URD, SID Dampers on a Single Zone Terminal Block No Isolation is Required!

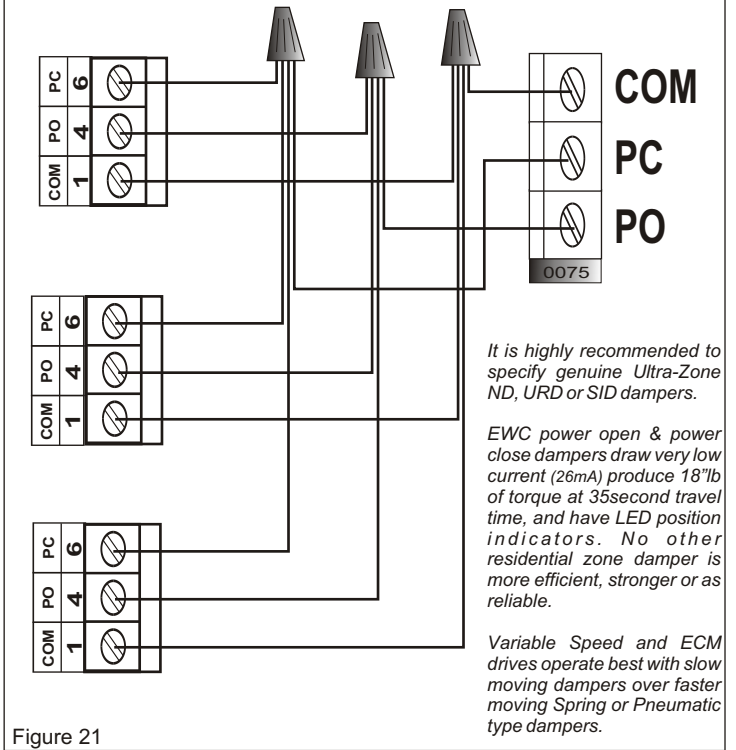

On all damper motors and most older style damper motors (including competitor's dampers) always wire up number to number or by terminal designations.

$$(C = Com = M1 = 1) - (PO = M4 = 4) - (PC = M6 = 6)$$

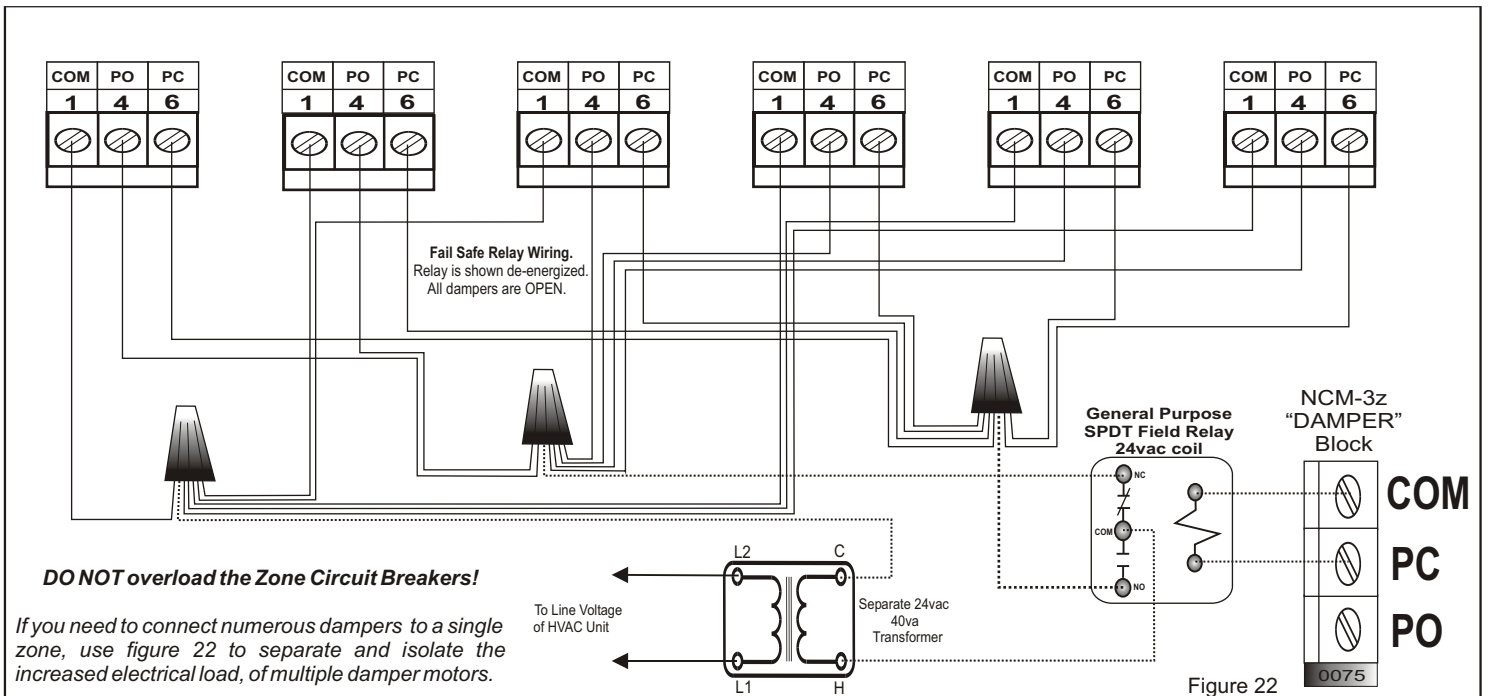

Model NCM-3z and DAPC [Power, Data & Zone Damper Wiring with Distributed Air Pressure Controller]

The NCM-3z Zone Control can send a digital (Damper Position) signal to the model DAPC, which can modulate your zone dampers to control the static pressure of the HVAC system...In order to achieve this function, the DAPC must be powered from the same 24vac transformer that powers the NCM-3z.

When using the "data" terminal, there is no need to connect your zone dampers direct to the NCM-3z. The NCM-3z will send digital Open/Close damper commands to the DAPC, and the DAPC will Open, Close or Modulate the dampers for you!

Install a "dedicated" 24vac transformer to the NCM-3z. Then route the 24vac Output & DATA wires from the NCM-3z to the DAPC.

Note: Accessory load (DAPC with 3 PO/PC damper motors) = 14va. Total connected load (includes 3 Thermostats) on the dedicated transformer = 28va.

Refer to the DAPC
Technical Bulletin #090375A0270
for detailed installation instructions!

Damper Wiring begins at the DAPC,
Not the Zone Control!

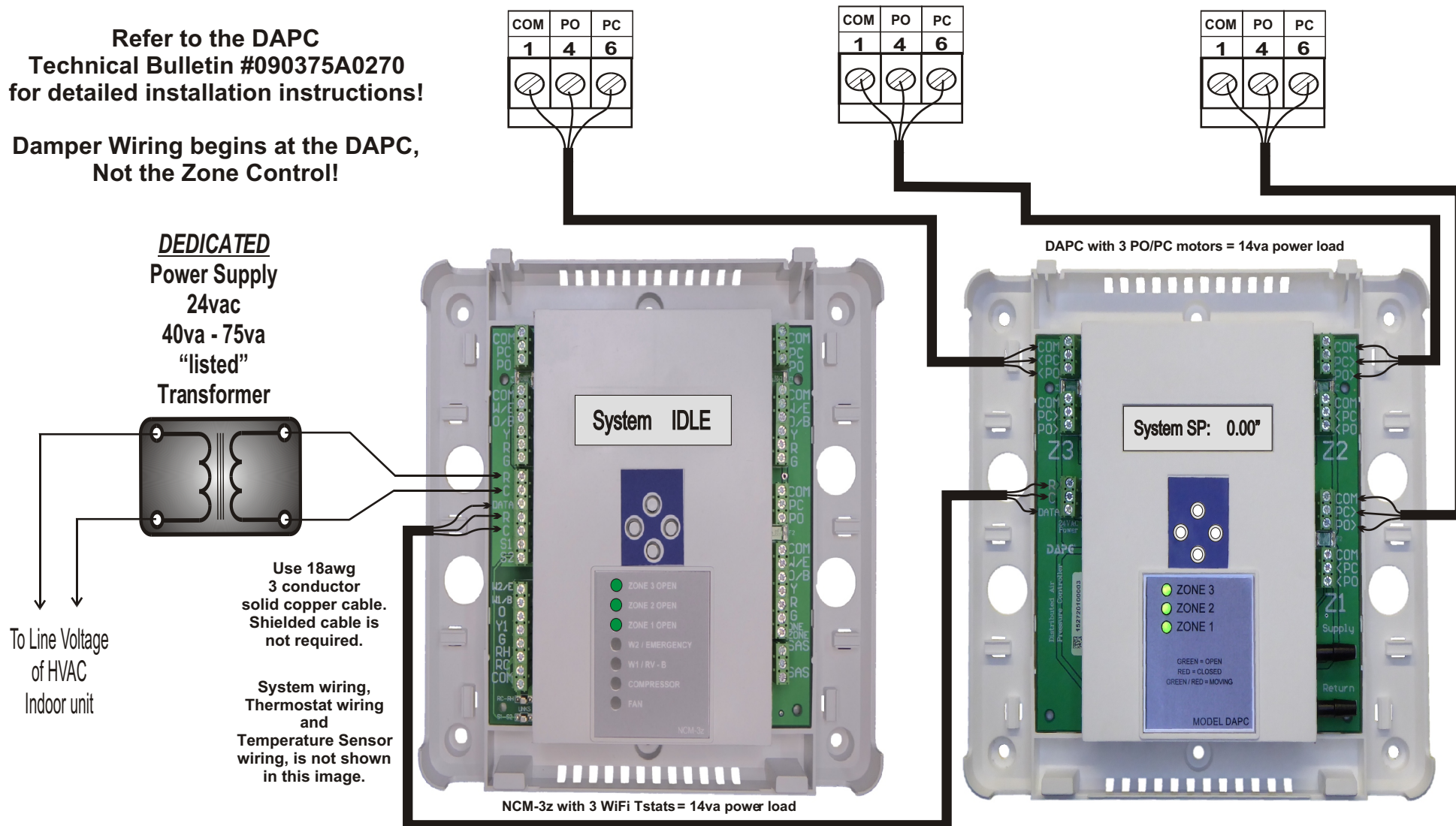

Model NCM-3z and Smart Bypass Damper [Power & Zone Damper Wiring with SBD2 Bypass]

You can use the NCM-3z 24vac "output" terminals to power additional components like the Smart Bypass Damper shown below. **Note:** The 24vac "output" terminals are located just below the 24vac "input" terminals. ***NCM-3z below with 3 T'stats (not shown) and 3 PO/PC motors = 24.5va load!***

You ***must*** make sure the NCM-3z is powered by a field installed "dedicated" 24vac (40va - 75va) transformer!...So long as you power the NCM-3z with a dedicated transformer, you may "add" more dampers or use the 24vac "output" terminals to power one or more additional components.

Important Note: If the additional component(s) result in significant load (VA), ***you may have to increase the VA rating of the dedicated 24vac power transformer.*** (50va - 75va).

Example Below: The SBD2 Bypass motor (1 additional component) is rated at 4va. ***40va dedicated transformer is sufficient.*** **Total load w/ SBD2 = 28.5va**

Example 2: Two more PO/PC dampers are required (5 dampers total) rated at 7va additional load. ***40va dedicated transformer is still sufficient.*** **New total load = 35.5va**

Example 3: A basic humidifier is needed (water solenoid with Rh controller) rated at 12va additional load. ***50va (or 75va) dedicated transformer is required.*** **New total load = 47.5va**

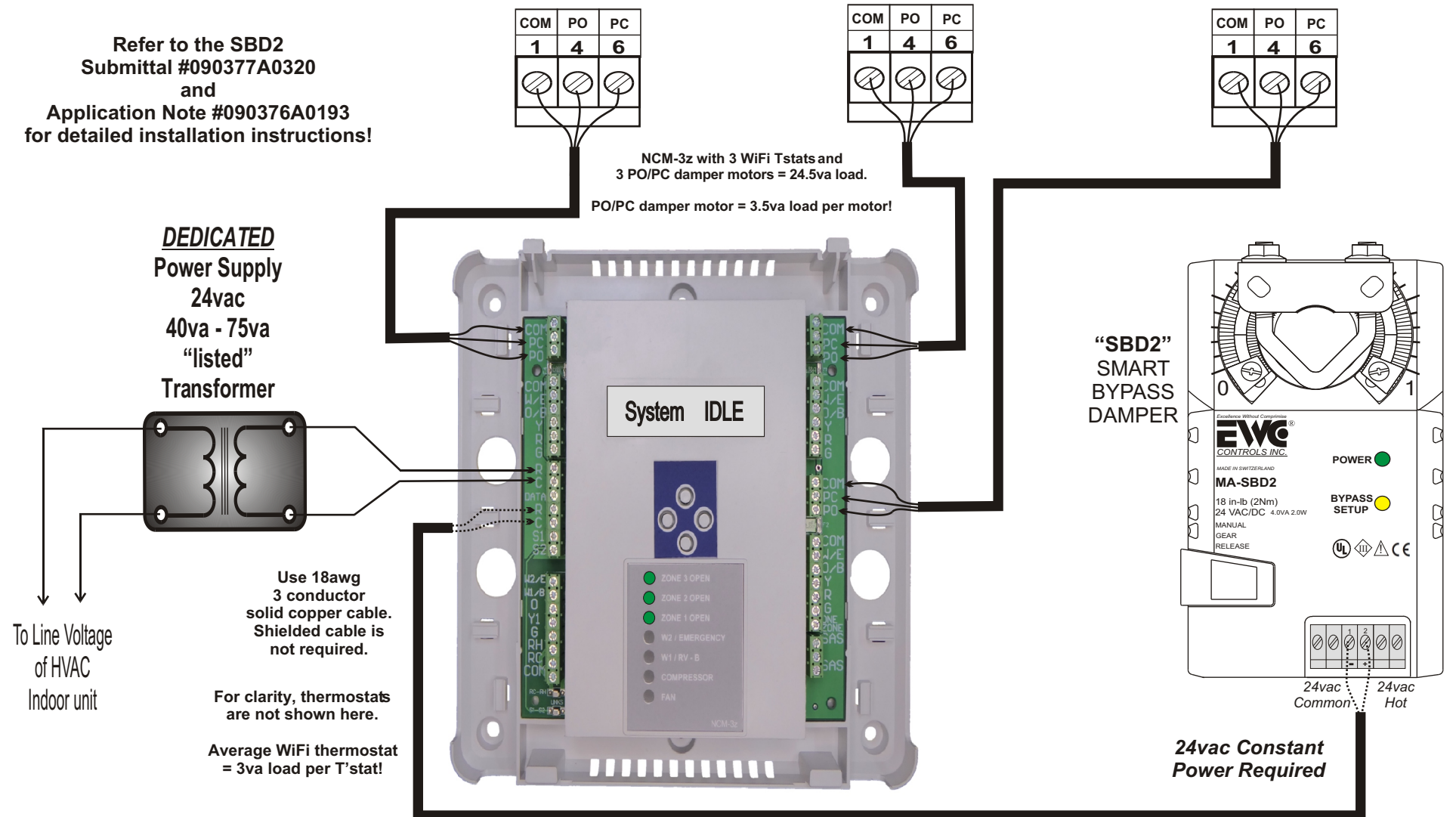

Model NCM-3z and Electronic Bypass Damper [Power & Zone Damper Wiring with EBD Bypass]

You can use the NCM-3z 24vac "output" terminals to power additional components like the Electronic Bypass Damper shown below. **Note:** The 24vac "output" terminals are located just below the 24vac "input" terminals. **NCM-3z below with 3 T'stats (not shown) and 3 PO/PC motors = 24.5va load!**

You **must** make sure the NCM-3z is powered by a field installed "dedicated" 24vac (40va - 75va) transformer!...So long as you power the NCM-3z with a dedicated transformer, you may "add" more dampers or use the 24vac "output" terminals to power one or more additional components.

Important Note: If the additional component(s) result in significant load (VA), **you may have to increase the VA rating of the dedicated 24vac power transformer.** (50va - 75va).

Example Below: The EBD Bypass motor (1 additional component) is rated at 3.5va. **40va dedicated transformer is sufficient. Total load w/ EBD = 28.0va**

Example 2: Three more PO/PC dampers are required (6 dampers total) rated at 10.5 va additional load. **50va dedicated transformer is now required. New total load = 38.5va**

Example 3: A basic humidifier is needed (water solenoid with Rh controller) rated at 12va additional load. **50va (or 75va) dedicated transformer is required. New total load = 50.5va**

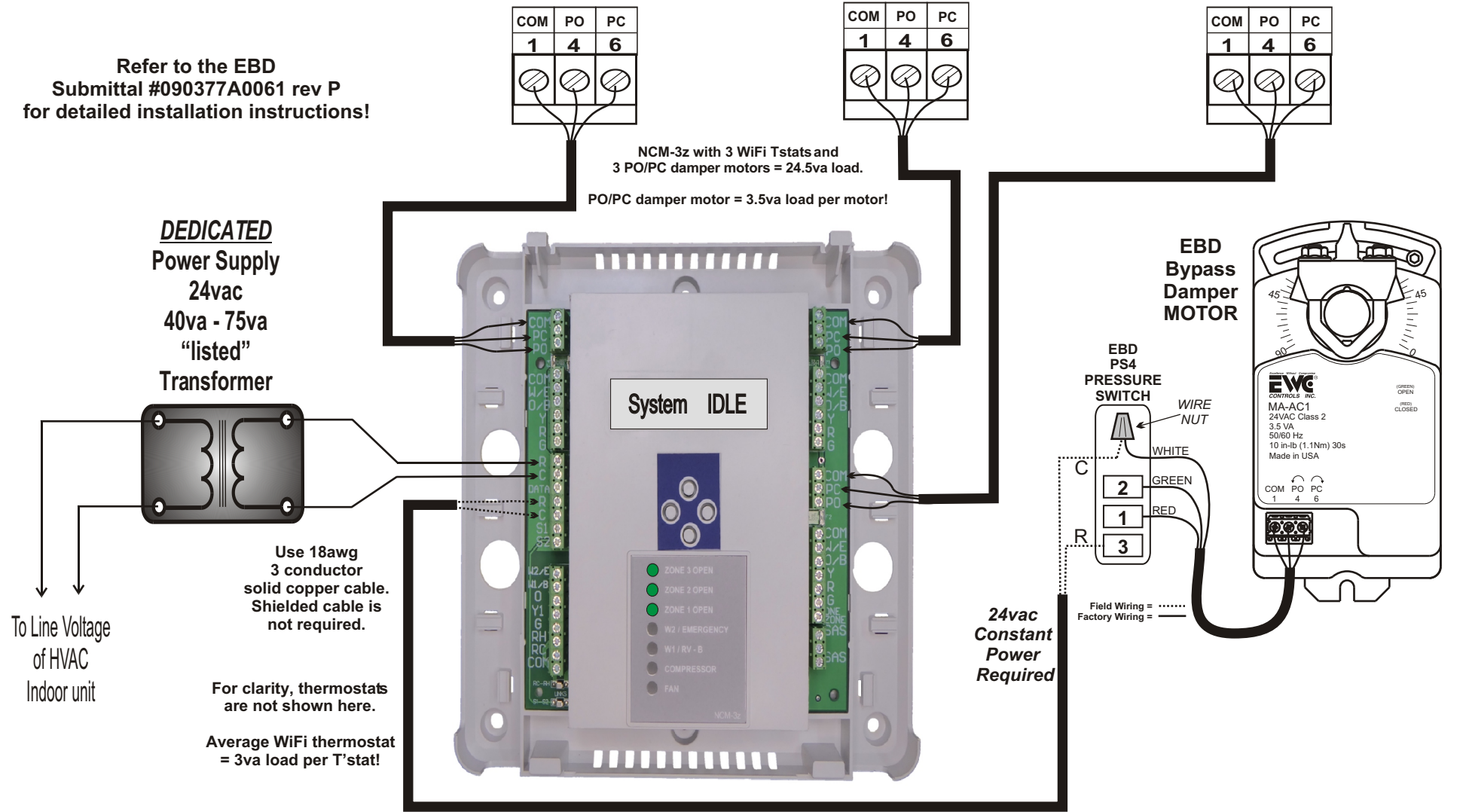

TROUBLESHOOTING

SYMPTOM	SOLUTIONS / CORRECTIVE ACTION
LCD & LED's are not illuminated. NCM-3z appears to be dead. HVAC system will not operate.	Check for power at the "24vac Power Input" terminal block. Check transformer line voltage. Check system line voltage. NCM-3z <i>must be powered by a dedicated 24vac transformer</i> (40va - 75va). DO NOT rob 24vac power from the HVAC system. Check wet switches that may interrupt 24vac power supply to the NCM-3z.
LED's illuminate but HVAC system does not respond. Or HVAC system does not respond & LCD displays "S1/S2 Lock-out"	Check for 24vac power at the "System" block and if zero, check HVAC system line voltage and 24vac power from the Furnace or Air Handler. Check low voltage fuse in Furnace or Air Handler. If 24vac is present at the "System" block, check wet switches or other safety devices that are wired to interrupt the S1/S2 circuit.
LCD & LED's function, but one or more zone thermostat/damper combos will not power up. Other zones work OK.	Check 24vac power (R&C) at the specific thermostat terminal block. If zero, the 750mA breaker protecting that zone has tripped. Check thermostat sub-base and damper circuit for improper wiring/connections. Use an Ohm meter and test thermostat wires for shorts to 24v common and shorts to earth ground. Check damper wiring for shorts as well. 24vac will restore automatically when the short is removed and repaired!
NCM-3z and HVAC system function, but poor heating/cooling performance	Check HVAC system Air Filter(s) and replace if dirty. Check for closed/faulty zone damper(s). Check for faulty/malfunctioning bypass damper. Check refrigerant level.
LCD displays "system too HOT/COLD" and the HVAC system is short cycling. OR the HVAC system is working but the LCD displays "Air Sensor Fault"	If a Supply Air Sensor (P# SAS) is connected to the NCM-3z and the actual supply air temperature exceeds the active Heating/Cooling limit value, a 4 minute delay must expire (<i>and the supply air temperature must moderate</i>) before HVAC functions resume. If the supply air sensor fails (<i>open sensor, shorted sensor or is disconnected</i>) HVAC functions will resume in 4 minutes, but the LCD will display "Sensor Fault" as a warning to check the sensor & sensor field wiring. Replace sensor if necessary.
SYMPTOM	SOLUTIONS / CORRECTIVE ACTION
HVAC system not responding but NCM-3z LCD & LED's are working.	If 24vac short has occurred in the "system" wiring, the equipment's 24vac low voltage fuse may be blown. Check equipment low voltage. Find & repair short.
One or more thermostats / damper motors will not power up.	Check 24vac power at the specific thermostat / damper motor terminal blocks. If zero, the related 750mA breaker has tripped. Disconnect wires. Find/repair shorts.
ISOLATING 24vac SHORTS <i>750mA circuit breakers protect each zone and react to a short in the Thermostat or Damper Motor field wiring.</i>	Disconnect wire(s) from the "R & C" terminals on the NCM-3z thermostat terminal blocks and the "C/PC/PO" terminals on the damper motor terminal blocks. If the short is no longer present the 750mA breaker will restore power automatically after a few minutes. Test the thermostat & damper field wiring for shorts to 24v common and to earth ground. Repair/replace wires as necessary.

NCM-3z LCD & LED DESCRIPTION, COLOR AND FUNCTION

LCD Active / Displays Data = 24vac power is available and processor is functioning.

LCD Active / Display is Dim or Washed out = Check Contrast setting. Adjust as necessary.

ZONE 1, 2 or 3 - Steady GREEN = Open Zones *or* OFF (*Not Green*) = Closed Zone. **Note:** All zones may be Open during idle periods.

W1/RV-B - Solid RED = Gas Heat or "B" reversing valve On-line *or* OFF (*Not Red*) Gas heat or "B" reversing valve Off-line.

W2/E - Solid RED = Auxiliary Heat or Emergency Heat On-line *or* OFF (*Not Red*) Auxiliary Heat/Emergency heat Off-line.

COMPRESSOR - Solid YELLOW = Compressor On-line *or* OFF (*Not Yellow*) = Compressor Off-line.

FAN - Solid GREEN = Fan On-line *or* OFF (*Not Green*) = Fan Off-line.

COMPRESSOR & FAN = Cooling On-line *or* Both LED's OFF (*not Yellow or Green*) = Cooling Off-line.

COMPRESSOR & FAN & W1/B = HP Heating On-Line *or* both LED's OFF (*no Compressor or Fan*) but W1/RV-B still ON = HP Heating Off-line, but holding "B" reversing valve signal waiting for next heat demand.

TECHNICAL SUPPORT

EWC Controls provides superior Troubleshooting Support for the NCM-3z when you are on the job site!

When calling for Technical Support from the job-site, please have a good quality multi-meter, pocket screwdriver, and wire cutters/strippers on hand. Call 1-800-446-3110 Monday - Friday 8am to 5pm EST.

Register your NCM-3z warranty at <https://ewcccontrols.com/warranty/>