

# SEZ7656R1045B / SEZ7656H1045B

Installation Guide for BACnet™ MS-TP RTU / HP

Room Controllers

For Commercial Zoning Systems



## CONTENTS

<b>Installation</b>	<b>2</b>
Location	2
Installation	2
<b>BACnet™ System Overview</b>	<b>3</b>
<b>Terminal, Identification and Function</b>	<b>4</b>
Wiring	4
Screw terminal arrangement and wiring	4
<b>Typical Applications</b>	<b>5</b>
Main outputs wiring	5
<b>Configuring and Status Display Instructions</b>	<b>7</b>
<b>User interface</b>	<b>9</b>

## INSTALLATION

Remove security screw on bottom of cover.

- Open unit by pulling on bottom side of Room Controller (Figure 1).
- Remove wiring terminals from sticker.
- Read FCC ID and IC label installed in the cover.

### Location

1. Should not be installed on outside wall.
2. Must be installed away from any direct heat source.
3. Should not be installed near air discharge grill.
4. Should not be affected by direct sun radiation.
5. Nothing should restrict vertical air circulation to Room Controller.

### Installation

1. Swing open the Room Controller PCB to the left by pressing PCB locking tabs (Figure 2).
2. Pull out cables 6" out from wall.  
Ensure wall surface is flat and clean.
4. Insert cable in central hole of base.
5. Align base and mark location of two mounting holes on the wall ensuring proper side of base up.
6. Install anchors in wall.
7. Insert screws in mounting holes on each side of base (Figure 2).
8. Gently swing back circuit board on base and push until the tabs lock.
9. Strip each wire 1/4 inch from end.
10. Insert each wire according to wiring chart (page 4).
11. Gently push excess wiring back into hole (Figure 3).
12. Re-Install wiring terminals in their correct locations (Figure 3).
13. Re-install cover (top side first) and gently push extra wire length back into hole in wall.
14. Install security screw.

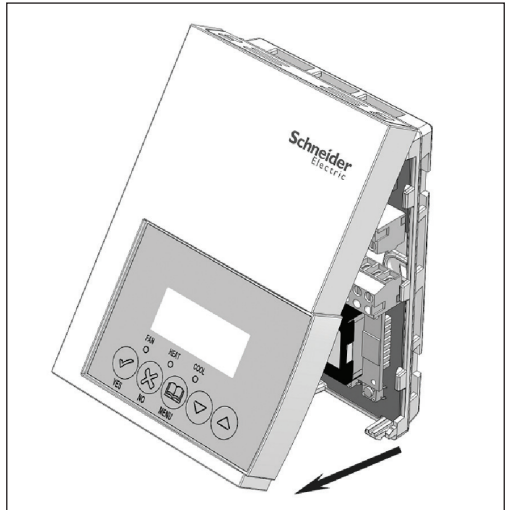

Figure-1 Opening the Cover

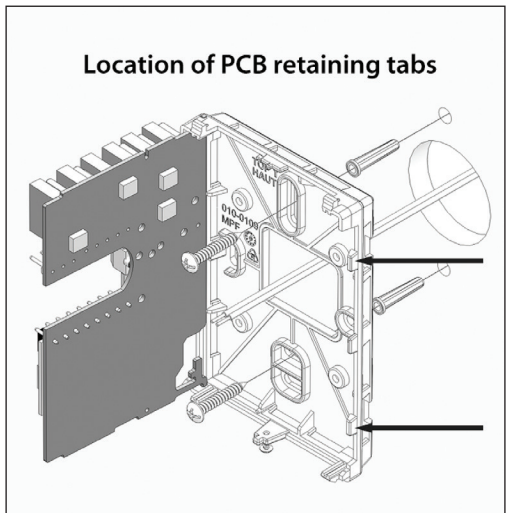

Figure-2 Opening the PCB

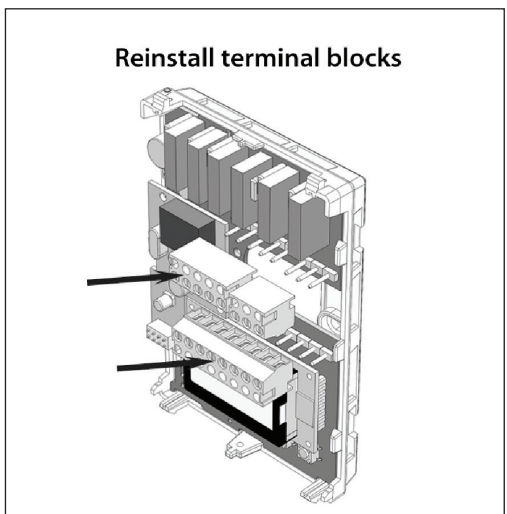

Figure-3 Terminal Block Reinstall



- When replacing an existing Room Controller, label the wires before removal of the Room Controller.
- Electronic controls are static sensitive devices. Discharge yourself properly before manipulating and installing the Room Controller.
- A short circuit or improper wiring may permanently damage the Room Controller or the equipment.
- All SEZ7000 series Room Controllers are designed for use as operating controls only and are not safety devices. These instruments have undergone rigorous tests and verification prior to shipping to ensure proper and reliable operation in the field. Whenever a control failure could lead to personal injury and or loss of property, it becomes the responsibility of the user or installer or electrical system designer to incorporate safety devices (such as relays, flow switch, thermal protections) and or an alarm system to protect the entire system against such catastrophic failures. Tampering with the devices or unintended application of the devices will result in a void of warranty.

## BACNET™ SYSTEM OVERVIEW

Schneider Electric SEZ7260X5x45B Zone controllers are used in conjunction with the SEZ7656x1045B roof top controllers. Combined, they are designed for operating typical; single or multistage RTU's and their associated local zones. For example, a typical job layout system may feature 3 RTU controllers and a total of 31 zones. This would bring to total number of nodes (individual Com addresses) to 34. RTU 1 would have 10 zones under its command, RTU 2 would have 10 zones under its command and RTU 3 would have 11 zones under its command.

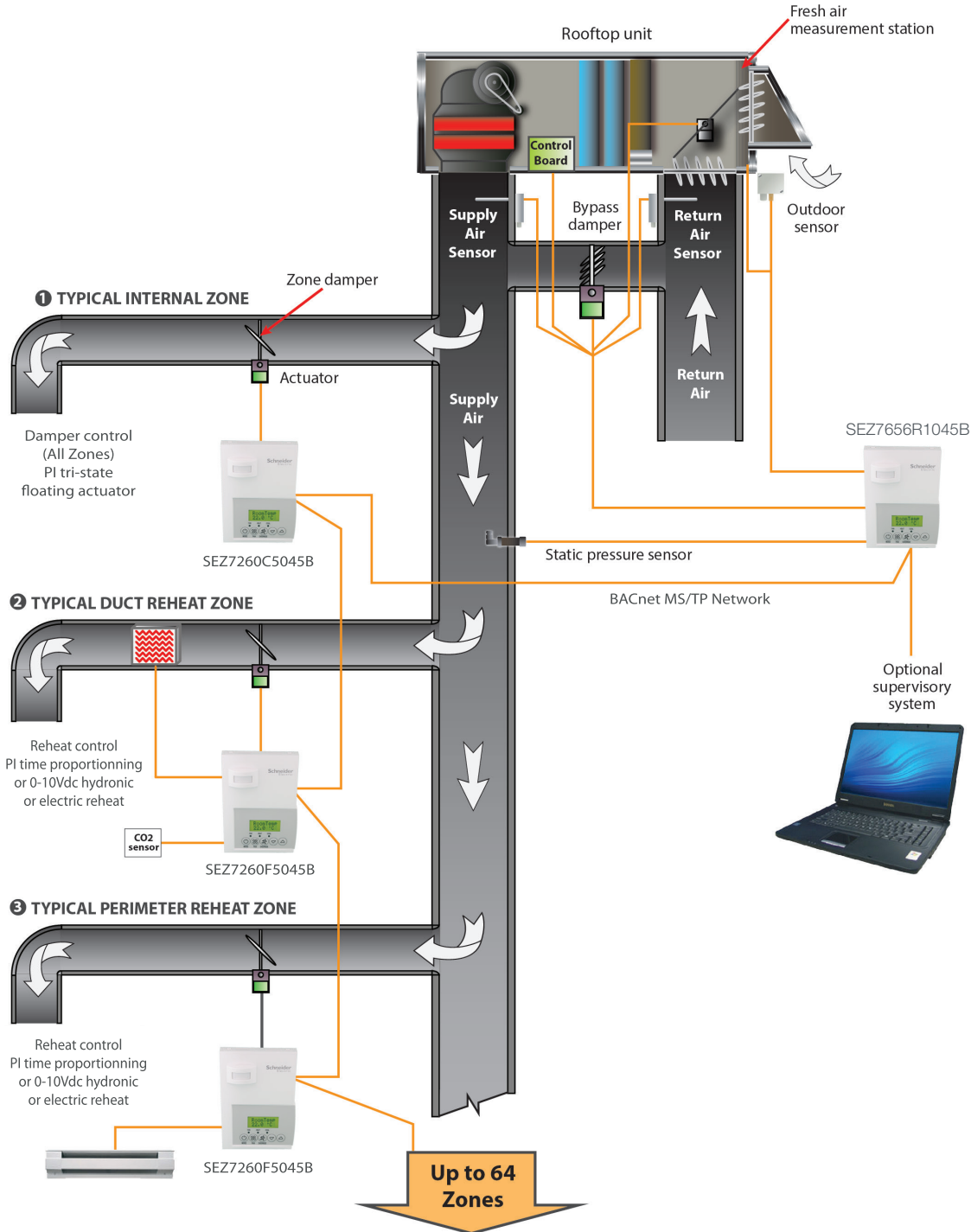

Typical BACnet™ Zoning System Installation

## TERMINAL, IDENTIFICATION AND FUNCTION

### Wiring

Terminal Use		Terminal Identification		Description
Rooftop	Heat Pump	RTU	HP	
1 – Cool 2	Compressor 2	<b>Y2</b>		Output for cooling / compressor stage number 2
2 – Cool 1	Compressor 1	<b>Y1</b>		Output for cooling / compressor stage number 1
3 - Fan		<b>G</b>		Output for the fan
4 - 24 V ~ Hot		<b>RC</b>		Power supply of controller, hot side (Delivered from the RTU).
5 - 0 V ~ Hot		<b>C</b>		Power supply of controller, common side. Also used as reference for the analog BPD output when used (Delivered from the RTU)
6- Heat Switch Leg		<b>RH</b>		<ul style="list-style-type: none"> <li>• 24 VAC switched leg for the heating stages.</li> <li>• If heating stages are part of RTU, install a jumper across RC &amp; RH</li> <li>• If heating stages are part of separate equipment with a different power supply, feed external switched power leg through RH <b>without</b> installing a jumper across RC &amp; RH.</li> </ul>
7 – Heat 1		<b>W1</b>		Output for heating stage number 1
8- Heat 2	Reversing valve	<b>W2</b>	<b>O/B</b>	Output for heating stage number 2 for SEZ7656R1045B Output for reversing valve for SEZ7656H1045B
9 – By-pass damper		<b>BPD</b>		Local analog 0 - 10 VDC by-pass damper / VFD output.
10 – Aux output		<b>AU</b>		Auxiliary output used to disable economizer damper minimum position or control lighting during unoccupied periods.
11 – Static pressure		<b>SP</b>		Local analog 0 – 5 VDC static pressure input.
12 – DI1		<b>DI</b>		Configurable extra digital input. See parameter section for more information.
13 - RS		<b>RS</b>		Return air temperature sensor input. If sensor fails, controller will use the on-board thermistor sensor to control if the communication is lost.
14 - Scom		<b>Scom</b>		Reference input for DI 1, RS, OS & DS.
15 - OS		<b>OS</b>		Outside air temperature sensor input.
16 - DS		<b>DS</b>		Discharge air temperature sensor input.

### BACnet™ Network Connections

BACnet™ Network Connections		
BACnet™ Com	<b>Com +</b>	BACnet™ communication bus + connection.
BACnet™ Com	<b>Com -</b>	BACnet™ communication bus – connection.
Ref	<b>Ref</b>	Communication bus reference terminal. <ul style="list-style-type: none"> <li>• <b>DO NOT USE FOR OTHER THAN SERVICING ISSUES</b></li> <li>• <b>DO NOT WIRE SHIELD TO THIS TERMINAL</b></li> </ul>

### Screw terminal arrangement and wiring

#### SEZ7656R Controller Terminals

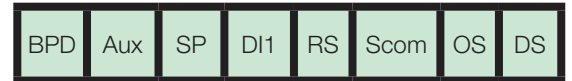
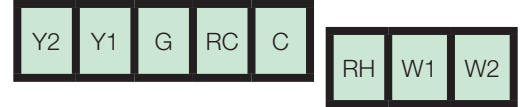

#### SEZ7656H Controller Terminals

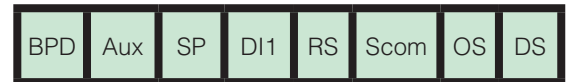
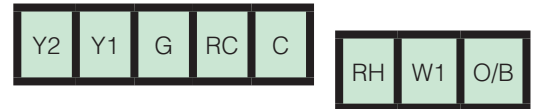

## TYPICAL APPLICATIONS

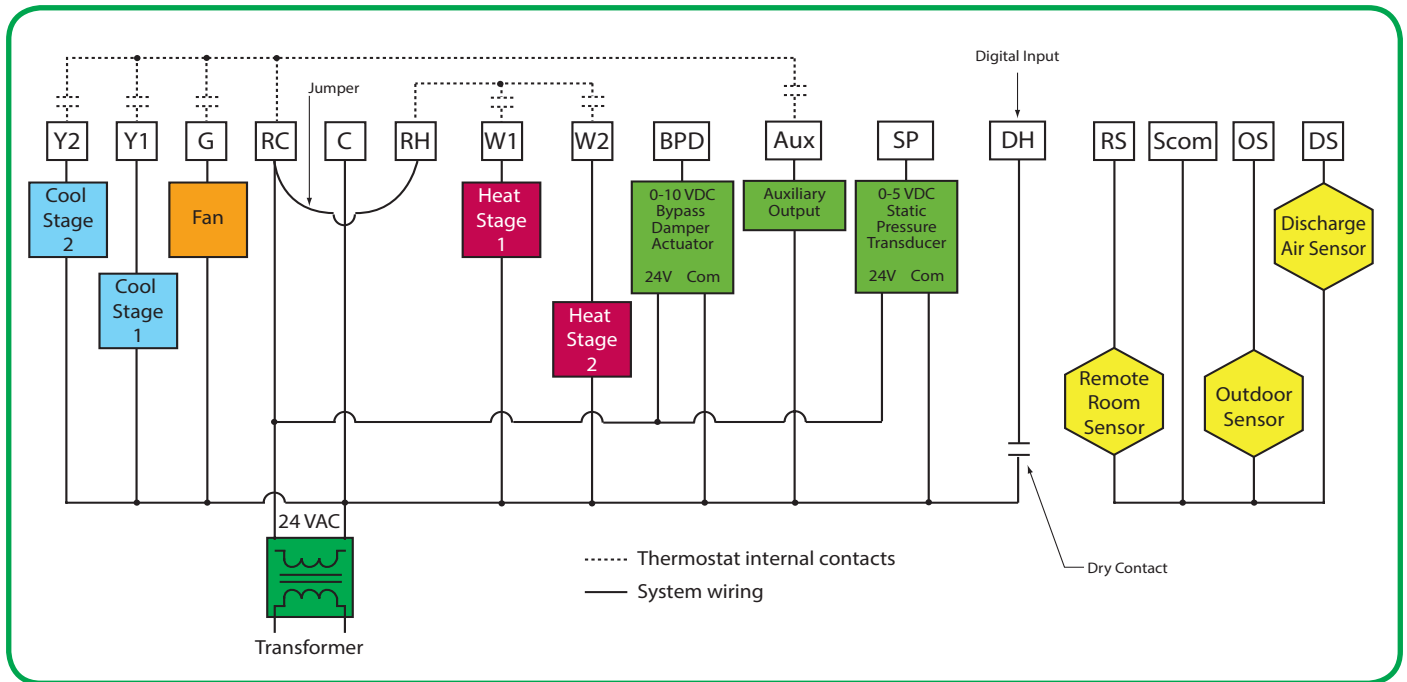

### Main outputs wiring

#### Wiring notes:

##### Note 1

If the same power source is used for the heating stages, install jumper across RC & RH. Maximum current is 2.0 amps.

##### Note 2

If auxiliary output is used to toggle occupancy of the electronic control card inside the equipment, configure the relay parameter (Aux cont) to the N.O. setting. A second relay can be added for additional functionality of the occupancy output.

##### Note 3

Analog outputs and inputs use a half bridge rectifier. Reference of the control signal is the common of the power supply of the Room Controller. (Terminal C)

##### Note 4

Electromechanical contacts are to be used with the digital inputs. Electronic triacs cannot be used as mean of switching for the input. The switched leg to the input for the input to activate is terminal C (common)

##### Note 5

The transformer of the unit provides power to the Room Controller and the additional loads that will be wired to the Room Controller.

##### Note 6

10K Type 2 NTC sensors are required.

Temperature vs. Resistance Chart for 10K Type 2 NTC Thermistor

$$(R_{25^{\circ}\text{C}} = 10\text{K}\Omega \pm 3\% - B_{25/85^{\circ}\text{C}} = 3975\text{K} \pm 1.5\%)$$

°C	°F	Kohm
-40	-40	324.3197
-39	-38	303.6427
-38	-36	284.4189
-37	-35	266.5373
-36	-33	249.8958
-35	-31	234.4009
-34	-29	219.9666
-33	-27	206.5140
-32	-26	193.9703
-31	-24	182.2686
-30	-22	171.3474
-29	-20	161.1499
-28	-18	151.6239
-27	-17	142.7211
-26	-15	134.3971
-25	-13	126.6109
-24	-11	119.3244
-23	-9	112.5028
-22	-8	106.1135
-21	-6	100.1268

°C	°F	Kohm
-20	-4	94.5149
-19	-2	89.2521
-18	0	84.3147
-17	1	79.6808
-16	3	75.3299
-15	5	71.2430
-14	7	67.4028
-13	9	63.7928
-12	10	60.3980
-11	12	57.2044
-10	14	54.1988
-9	16	51.3692
-8	18	48.7042
-7	19	46.1933
-6	21	43.8268
-5	23	41.5956
-4	25	39.4921
-3	27	37.5056
-2	28	35.6316
-1	30	33.8622

°C	°F	Kohm
0	32	32.1910
1	34	30.6120
2	36	29.1197
3	37	27.7088
4	39	26.3744
5	41	25.1119
6	43	23.9172
7	45	22.7861
8	46	21.7151
9	48	20.7004
10	50	19.7390
11	52	18.8277
12	54	17.9636
13	55	17.1440
14	57	16.3665
15	59	15.6286
16	61	14.9280
17	63	14.2629
18	64	13.6310
19	66	13.0307

°C	°F	Kohm
20	68	12.4601
21	70	11.9177
22	72	11.4018
23	73	10.9112
24	75	10.4443
25	77	10.0000
26	79	9.5754
27	81	9.1711
28	82	8.7860
29	84	8.4190
30	86	8.0694
31	88	7.7360
32	90	7.4182
33	91	7.1150
34	93	6.8259
35	95	6.5499
36	97	6.2866
37	99	6.0351
38	100	5.7950
39	102	5.5657

°C	°F	Kohm
40	104	5.3467
41	106	5.1373
42	108	4.9373
43	109	4.7460
44	111	4.5631
45	113	4.3881
46	115	4.2208
47	117	4.0607
48	118	3.9074
49	120	3.7607
50	122	3.6202
51	124	3.4857
52	126	3.3568
53	127	3.2333
54	129	3.1150
55	131	3.0016
56	133	2.8928
57	135	2.7886
58	136	2.6886
59	138	2.5926

Wiring for 10K Type 2 NTC Thermistor Sensors

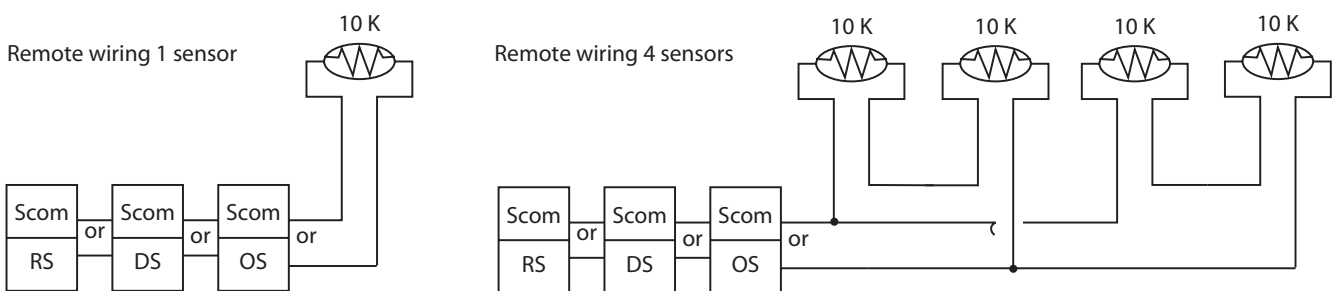

## CONFIGURING AND STATUS DISPLAY INSTRUCTIONS

### Status display

The Room Controller features a two-line, eight-character display. There is a low backlight level that is always active and can only be seen at night. When left unattended, the Room Controller has an auto scrolling display that shows the current status of the system.

Each item is scrolled sequentially with the back lighting in low level mode. Pressing any key will cause the back lighting to come on to high level.

Manual scrolling of each menu item is achieved by pressing the Yes (scroll) key repetitively. The last item viewed will be shown on the display for 30 seconds before returning to automatic scrolling. Temperature is automatically updated when scrolling is held.

### Sequence of auto-scroll status display:

CLOCK STATUS	SYSTEM MODE	SCHEDULE STATUS	OUTDOOR TEMP.	ALARMS
Monday 12:00 AM	Sys Mode Auto	Occupied	Outdoor x.x °C or °F	Service
	Sys Mode Off	Occupied hold		DAS Alrm
	Sys Mode Heat	Unoccup		SetClock
	Sys Mode Cool			Filter
				Comm lost

### Outdoor air temperature

- Outdoor air temperature display is only enabled when outdoor air temperature sensor is connected.
- A maximum range status display of 50 °C (122 °F) indicates a shorted sensor. Associated functions, such as mode lockouts and economizer function are automatically disabled.
- A minimum range status -40 °C (-40 °F) is not displayed and indicates a opened sensor or a sensor not connected. Associated functions, such as mode lockouts and economizer function are automatically disabled.



### Alarms

- If alarms are detected, they will automatically be displayed at the end of the status display scroll.
- During an alarm message display, the back lit screen will light up at the same time as the message and shut off during the rest of the status display.
- Two alarms maximum can appear at any given time.
- The priority for the alarms is as follows:

### Sequence of manual-scroll status display:

Manual scroll of each menu item is achieved by pressing the Yes (scroll) key repetitively. The last item viewed will be shown on the display for 30 seconds before returning to automatic scrolling. Temperature is automatically updated when scrolling is held.

CLOCK STATUS	SYSTEM MODE	SCHEDULE STATUS	OUTDOOR TEMP.	ALARMS (if detected)
Monday 12:00 AM	Sys Mode Off	Occupied	Outdoor x.x °C or °F	Service
	Sys Mode Auto	Unoccupied		DAS Alarm
	Sys Mode Cool	Override		SetClock
	Sys Mode Heat			Filter
				Comm Lost

	When any of the fan speeds are <b>ON</b> , the <b>FAN LED will illuminate.</b>
	When heating is <b>ON</b> , the <b>HEAT LED will illuminate.</b>
	When cooling is <b>ON</b> , the <b>COOL LED will illuminate.</b>

CURRENT ZONE SEQUENCE	RETURN AIR TEMP	DISCHARGE AIR TEMP	CURRENT STATIC PRESSURE
Zone Seq Off	RA Temp xx.x °C or °F	DA Temp xx.x °C or °F	Pressure x.x WC or Pa
Zone Seq Cool			
Zone Seq Heat			

EFFECTIVE PI HEAT DEMAND AT RTU	EFFECTIVE PI COOL DEMAND AT RTU	HIGHEST PI HEAT DEMAND ZONE ADDRESS	HIGHEST PI COOL DEMAND ZONE ADDRESS
Heat Out xxx %	Cool Out xxx %	Heat MAC xxxx	Cool MAC xxx

<b>Service</b>	Indicates that there is a service alarm as per one of the configurable digital input (DI1 or DI2)
<b>DAS Alarm</b>	Indicates that the discharge air temperature is either too low or too high.
<b>SetClock</b>	Indicates that the clock needs to be reset. There has been a power failure which has lasted longer than 6 hours.
<b>Filter</b>	Indicates that the filters are dirty as per one of the configurable digital input (DI1 or DI2)
<b>Comm Lost</b>	The communication between devices has been lost (No Communication)

## USER INTERFACE

### User configuring instructions menu

The SEZ7656X series of controllers feature an intuitive, menu-driven, back-lit LCD display that walks users and installers through the configuring steps, making the configuring process extremely simple. This menu is typically accessed by the user to set the parameters such as the clock time set, the schedule time events and the system mode.







It is possible to bring up the user menu at any time by depressing the MENU key. The status display automatically resumes after exiting the user-configuring menu.

If the user pauses at any given time during configuring, **Auto Help** text is displayed to help and guide the user through the usage and configuring of the controller.

#### Ex.: Press yes key to change cooling temperature setpoint Use the up or down arrow to adjust cooling setpoint

Each of the sections in the menu is accessed and configured using 5 keys on the controller cover. The priority for the alarms is as follows:

### Local Keypad Interface

	The <b>YES</b> key is used to confirm a selection, to move onto the next menu item and to manually scroll through the displayed information.
	The <b>NO</b> key is used when you do not desire a parameter change, and to advance to the next menu item. Can also be used to toggle between heating and cooling setpoints.
	The <b>MENU</b> key is used to access the Main User Menu or exit the menu.
	The <b>DOWN</b> arrow key is used to decrease temperature setpoint and to adjust the desired values when configuring the Room Controller.
	The <b>UP</b> arrow key is used to increase temperature setpoint and to adjust the desired values when configuring the Room Controller.

Refer to SE7600 User Guide on Schneider Electric Downloads Exchange for Further Details.