

6

5

4

3

2

1

- NOTES:
 1. MATERIAL: 6063 ALUMINUM
 2. FINISH: POWDER COAT

REVISIONS				
REV.	DESCRIPTION	DRAWN BY	APPR BY	APPR DATE

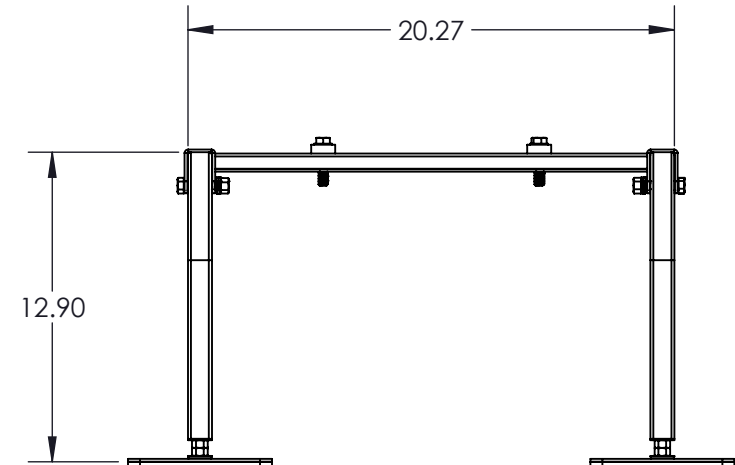
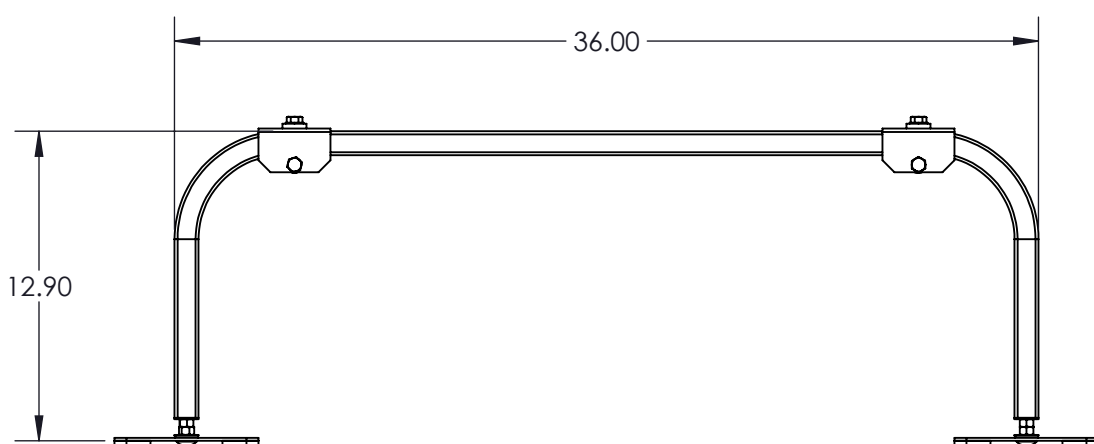
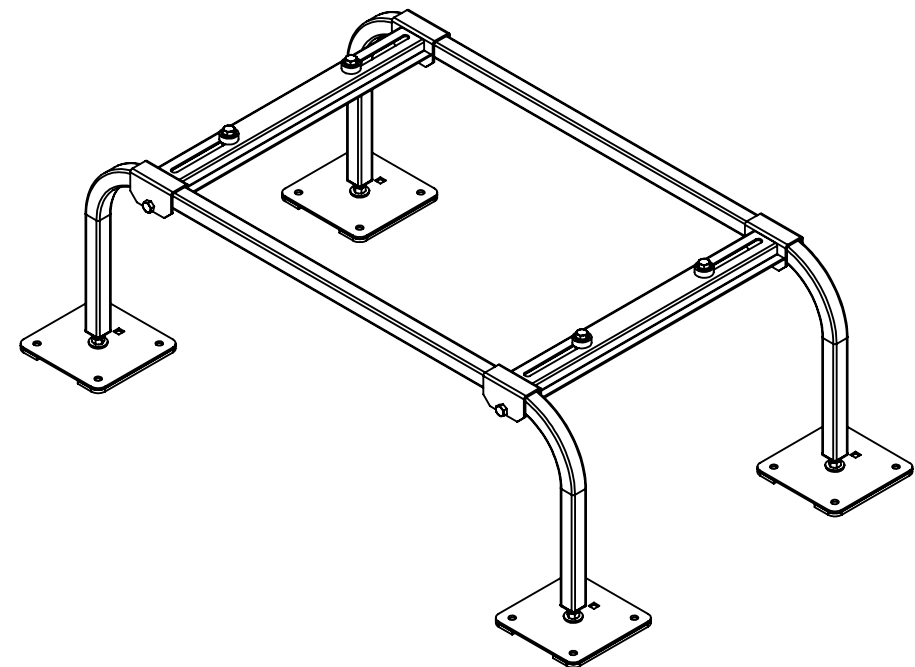
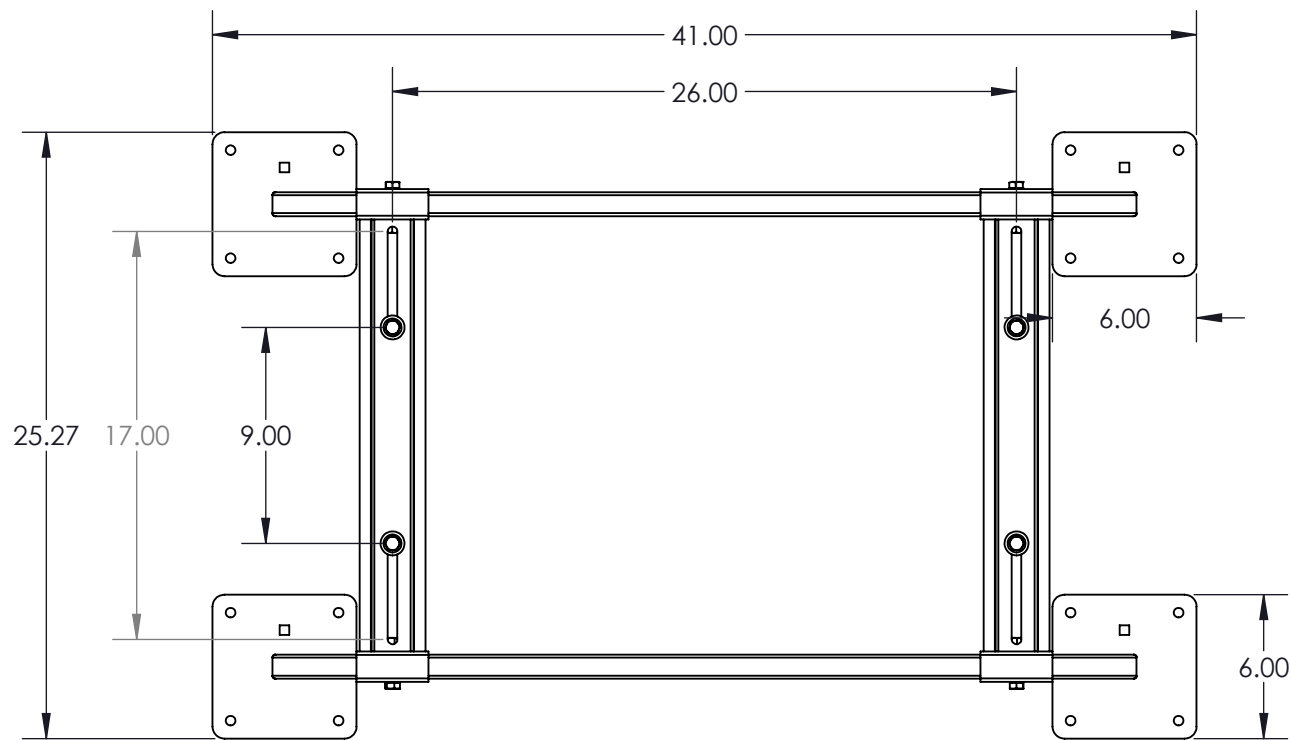

ALL DRAWINGS AND WRITTEN MATERIAL CONTAINED HEREIN ARE THE PROPERTY OF DIVERSITECH CORP AND MAY NOT BE DUPLICATED OR DISCLOSED AT ANY TIME UNLESS APPROVED IN WRITING BY DIVERSITECH CORP INTERPRET THIS DRAWING IN ACCORDANCE WITH ASME Y14.5-2009 DIMENSIONING AND TOLERANCING STANDARDS	UNLESS OTHERWISE SPECIFIED DIMENSIONS & TOLERANCES ARE IN INCHES		DEBURR ALL SHARP EDGES *DO NOT SCALE*			TITLE		SIZE
	DIM RANGE	TOLERANCE				THIRD ANGLE PROJECTION 		DRAWING NUMBER
0.02 - 0.12			±0.008	DRAWN BY: apadilla CAD APPR. DWG APPR.	DATE: 11 Aug 22	QSMS1201-PAL		B
0.12 - 0.24	±0.012	SCALE: 1:1				SHEET 1 OF 1		
0.24 - 1.18	±0.020							
1.18 - 4.72	±0.031							
4.72 - 15.75	±0.047							
15.75 - 39.4	±0.079							
39.4 +	±0.118							

6

5

4

3

2

1