

FL-22529.1

L.H. WELDMENT
R.H. WELDMENT

TYPICAL ACB
WALL BRACKET
SYSTEM

GENERAL NOTES:

- 1) All four (4) wall bracket models characterized in this document: ACB-30, ACB-36, ACB-42 & ACB-48 are designed to conform to the requirements as determined in the Florida Building Code 6th Edition (2017) and ASCE7-10.
- 2) These four products/models are all designed for use within and outside of High Velocity Hurricane Zones, including Miami/Dade.
- 3) Building structure must be designed by licensed professional engineer to carry the loads applied from the selected wall bracket.
- 4) Wall bracket materials shall be AISI 1045 steel or equivalent or stronger with $S_y \geq 59\text{ksi}$.
- 5) All anchors used to mount wall bracket to surrounding structure shall be as specified in these drawings, any substitutions shall be approved by a licensed professional engineer.
- 6) All hardware used (screws/fasteners) shall be corrosion resistant.
- 7) Alterations or additions to this document are not permitted.

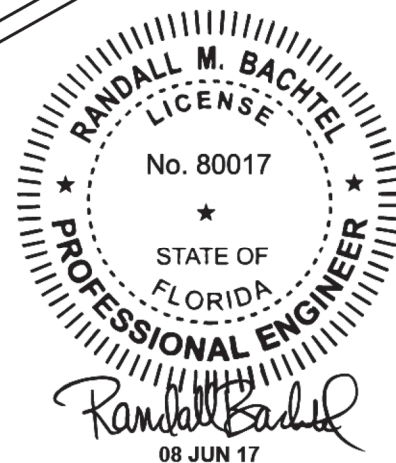

TABLE-1 CONDENSER UNIT (MAXIMUM) SPECIFICATIONS FOR ACB-30, ACB-36, ACB-42 & ACB-48 WALL BRACKETS

Item	ACB-30	ACB-36	ACB-42	ACB-48
Max. Length (a) in.	44	44	48	48
Max. Height (b) in.	54	50	46	42
Max. Depth (c) in.	24	28	34	40
Max. Frontal Area (a x b) sq. in.	2380	2200	2210	2220
Max. Lateral Area (b x c) sq. in.	1300	1400	1570	1680
Max. Weight (lbs.)	600	600	600	600

UNLESS OTHERWISE SPECIFIED:
DIMENSIONS ARE IN INCHES [MILLIMETERS]
TOLERANCES ARE: ANGLES $\pm 1.0^\circ$
FRACTIONAL SIZES X/Y $\pm 1/64$

INCHES [MILLIMETERS]
X = ± 0.1 [X = ± 2.5]
XX = ± 0.01 [X = ± 1.3]
XXX = ± 0.005 [XX = ± 0.13]

THIRD ANGLE PROJECTION



CONFIDENTIAL - PROPRIETARY - DO NOT COPY
THE INFORMATION SET FORTH IN THIS DOCUMENT AND RELATED INFORMATION IS THE CONFIDENTIAL PROPERTY OF DIVERSiTECH CORPORATION, AND IS NOT TO BE COPIED OR REPRODUCED OR DISTRIBUTED IN ANY FORM WITHOUT PRIOR WRITTEN PERMISSION FROM DIVERSiTECH CORPORATION.

DO NOT SCALE DRAWING

DESCRIPTION: Models: ACB-30, ACB-36, ACB-42 & ACB-48

MATERIAL: AISI 1045 Steel / $S_y \geq 59\text{ksi}$

DWG. NO. A/C Condensing Unit Wall Bracket Systems

REV. A

28AUG17

SHEET 1 OF 5

These drawing views (pg. 2) illustrate the wall bracket model ACB-30. All dimensions shown in these views including Section Views A-A, B-B & C-C and "Bracket Mounting Face" apply to all four (4) ACB Wall Bracket models including: ACB-30, ACB-36, ACB-42 & ACB-48. Unit specific dimensions are found on pg. 3.

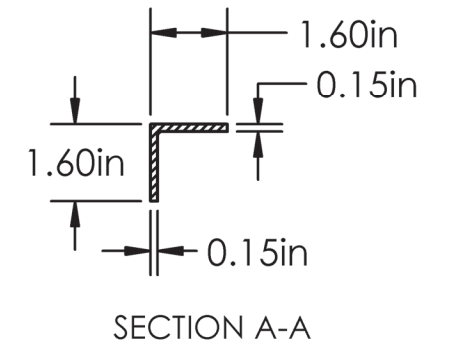
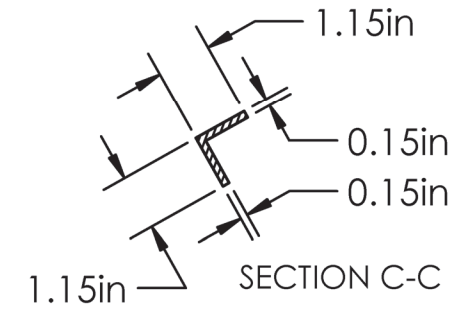
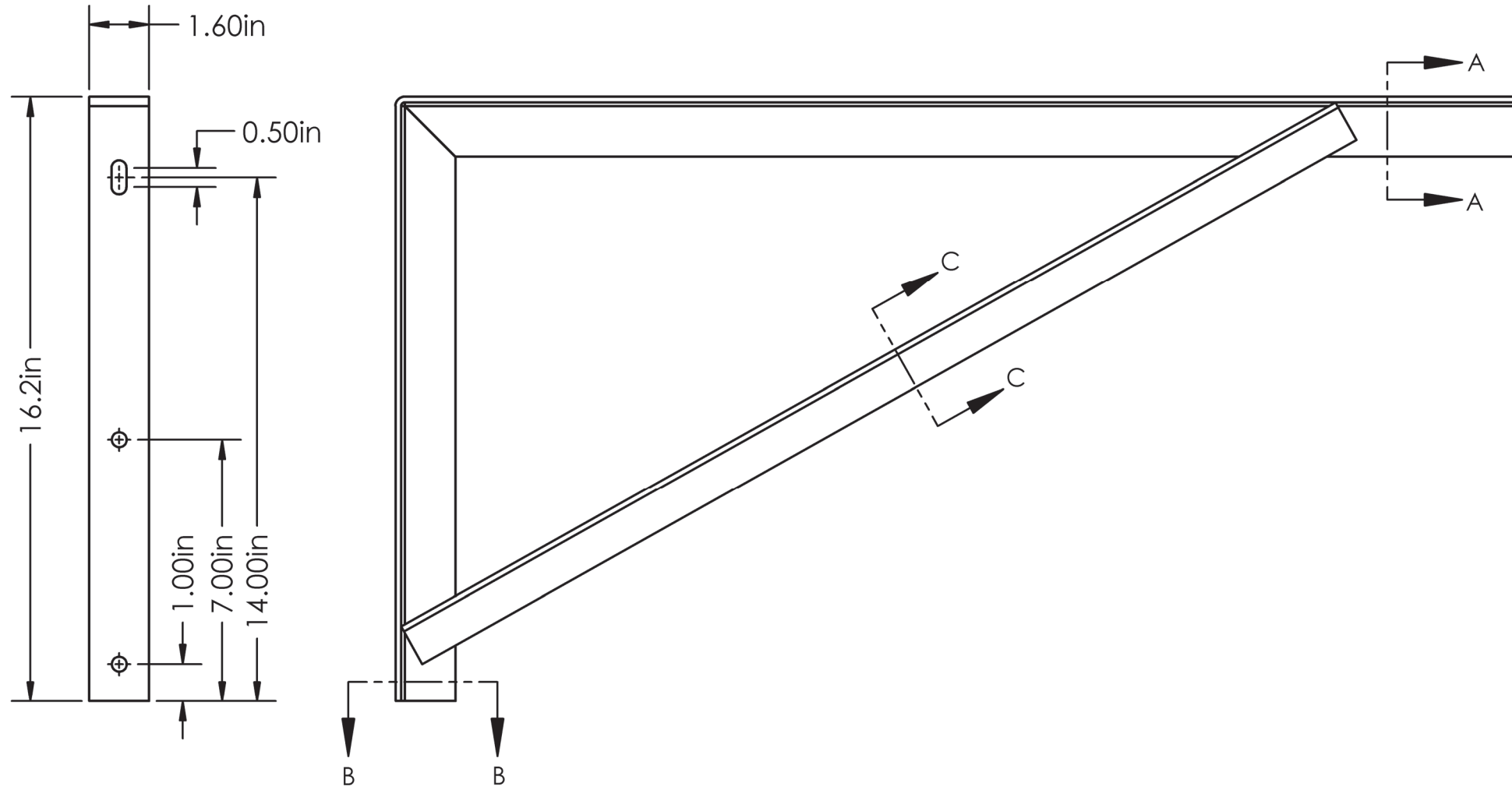

Bracket Mounting Face

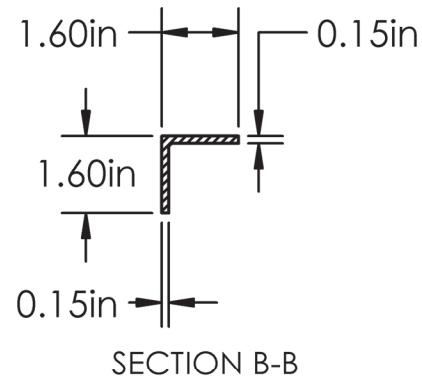
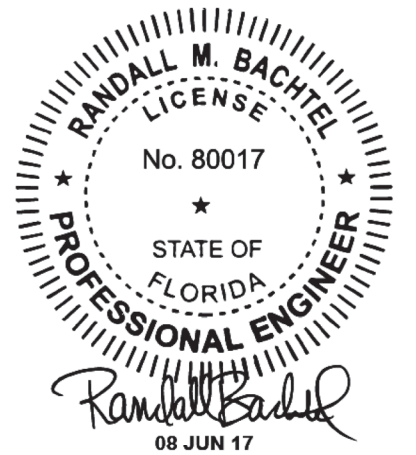

TABLE-2 WIND / VELOCITY PRESSURE CALCULATIONS FOR ALL WALL BRACKET DESIGNS

Max. Building Height (ft)	30	30	30	30	50	50	50	50	100
Risk Category	II	II	III/IV	III/IV	II	II	III/IV	III/IV	II
Exposure	C	D	C	D	C	D	C	D	C
Max. Wind Speed (MPH)	180	180	200	200	180	180	200	200	180
Max. Wind Pressure (psf)	63.1	86.2	90.4	107	81.4	94.8	100.5	117.1	94.1



UNLESS OTHERWISE SPECIFIED:
 DIMENSIONS ARE IN INCHES [MILLIMETERS]
 TOLERANCES ARE: ANGLES $\pm 1.0^\circ$
 FRACTIONAL SIZES X/Y $\pm 1/64$

INCHES	MILLIMETERS
X = ± 0.1	[X = ± 2.5]
XX = ± 0.01	[X = ± 1.3]
XXX = ± 0.005	[XX = ± 0.13]

THIRD ANGLE PROJECTION



CONFIDENTIAL - PROPRIETARY - DO NOT COPY
 THE INFORMATION SET FORTH IN THIS DOCUMENT AND RELATED INFORMATION IS THE CONFIDENTIAL PROPERTY OF DIVERSiTECH CORPORATION, AND IS NOT TO BE COPIED OR REPRODUCED OR DISTRIBUTED IN ANY FORM WITHOUT PRIOR WRITTEN PERMISSION FROM DIVERSiTECH CORPORATION.
 DO NOT SCALE DRAWING
 DESCRIPTION: Models: ACB-30, ACB-36, ACB-42 & ACB-48

MATERIAL: AISI 1045 Steel / $S_y \geq 59\text{ksi}$
 DWG. NO. A/C Condensing Unit Wall Bracket Systems

REV **A**
 28AUG17
 SHEET 2 OF 5

These drawing views (pg. 3) illustrate the four wall bracket specific dimensions. These four views are all plan views showing the mounting surface of each model/size.

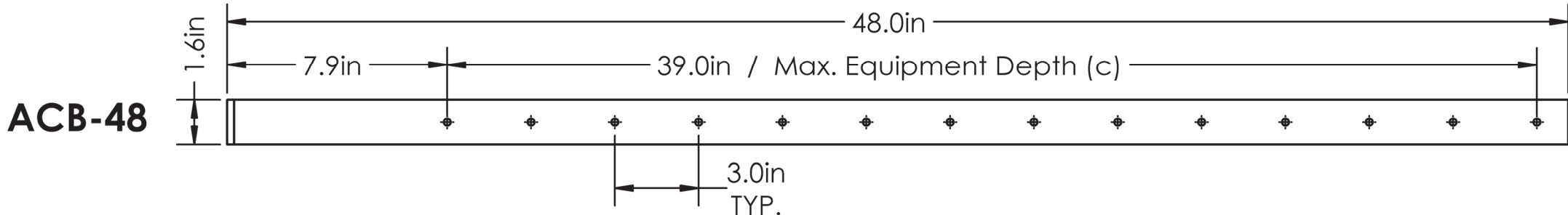
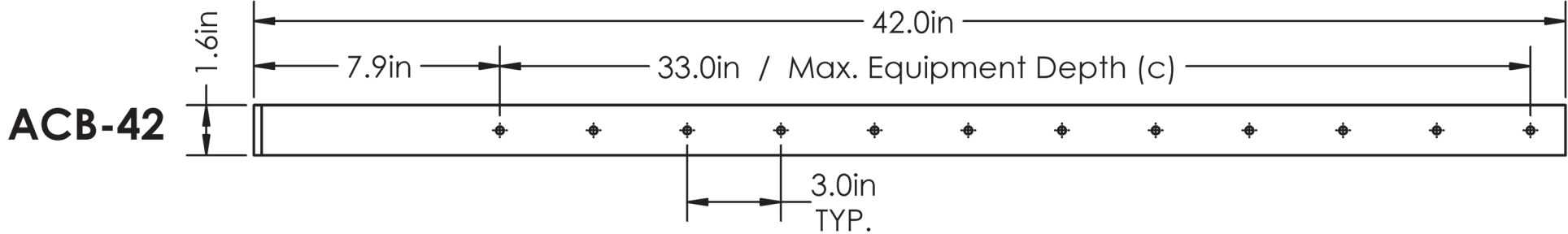
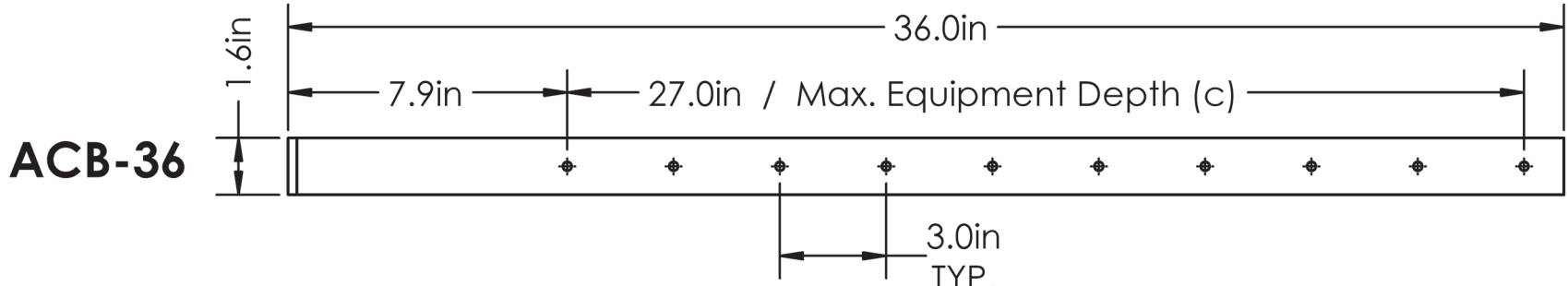
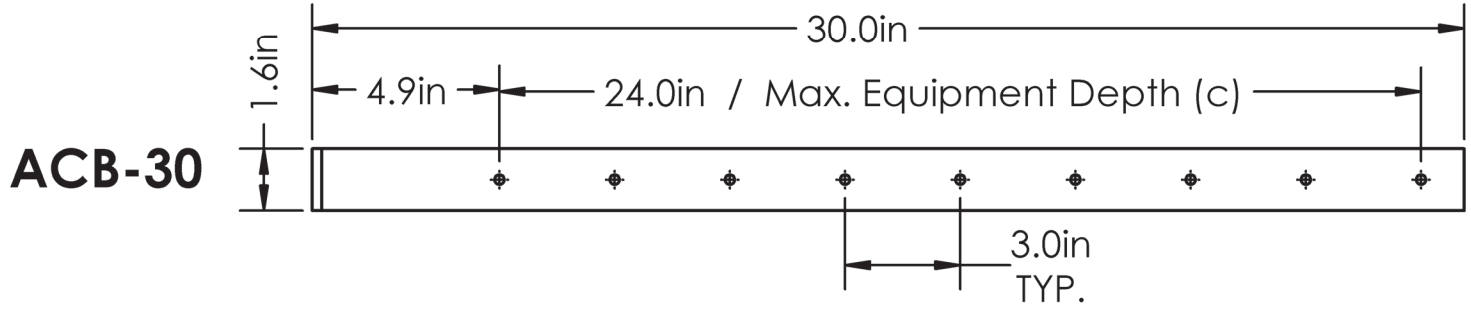
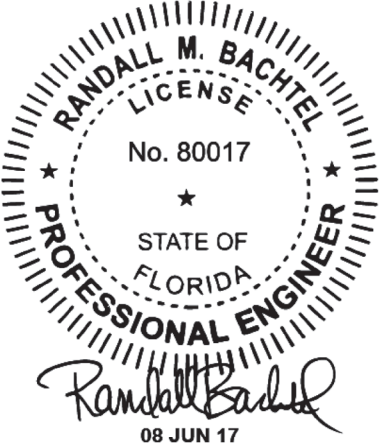

UNLESS OTHERWISE SPECIFIED:
 DIMENSIONS ARE IN INCHES [MILLIMETERS]
 TOLERANCES ARE: ANGLES ±1.0°
 FRACTIONAL SIZES X/Y ±1/64

INCHES	MILLIMETERS
X = ±0.1	[X = ± 2.5]
XX = ±0.01	[X = ± 1.3]
XXX = ±0.005	[XX = ±0.13]

THIRD ANGLE PROJECTION



CONFIDENTIAL - PROPRIETARY - DO NOT COPY
 THE INFORMATION SET FORTH IN THIS DOCUMENT AND RELATED INFORMATION IS THE CONFIDENTIAL PROPERTY OF DIVERSiTECH CORPORATION, AND IS NOT TO BE COPIED OR REPRODUCED OR DISTRIBUTED IN ANY FORM WITHOUT PRIOR WRITTEN PERMISSION FROM DIVERSiTECH CORPORATION.
 DO NOT SCALE DRAWING

MATERIAL: AISI 1045 Steel / $S_y \geq 59\text{ksi}$
 DWG. NO. A/C Condensing Unit Wall Bracket Systems

REV **A**
 28AUG17
 SHEET 3 OF 5

DESCRIPTION Models: ACB-30, ACB-36, ACB-42 & ACB-48

ACB Wall Bracket Anchor Schedule

Each ACB Wall Bracket System has 1 RH & 1 LH weldment / bracket. Mounting each bracket to the supporting structure requires 3 anchors for a total of 6 anchors per ACB wall bracket system. Each of the ACB sizes/models including: ACB-30, ACB-36, ACB-42 & ACB-48 will use the anchor schedules below. Any deviations from these anchor schedules must be approved by a licensed professional engineer.

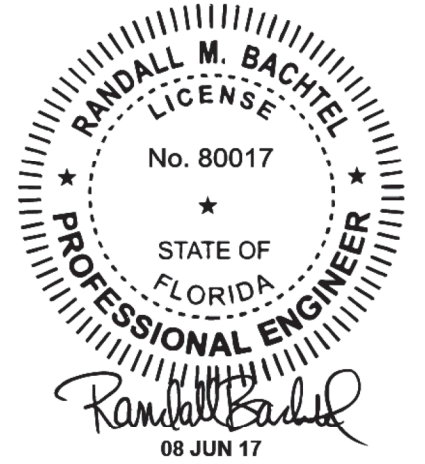

For $f'_c > 3000$ psi (20.7 MPa) Concrete – Cracked & Uncracked – 100' BLDG – Risk Cat. II – Exposure C

Anchor Size (Select Any Below)	Minimum Embedment	Minimum Edge Distance
3/8" Titen HD anchors	3 – 3/4"	4 – 1/2"
3/8" Strong-Tie Strong Bolt	2"	6"
3/8" Hilti KWIK Bolt TZ	2 – 5/16"	4"
3/8" Heavy Duty Tapcon	2 – 1/2"	4"
5/16" Heavy Duty Tapcon	1 – 3/4"	4"

For $f'_c > 2000$ PSI (13.8 MPa) Grout-Filled CMU – 50' BLDG – Risk Cat. II, III & IV – Exposure C & D

For 8-inch Lightweight, Medium-Weight and Normal-Weight Hollow CMU – 30' BLDG – Risk Cat. II – Exposure C

For 8-inch Lightweight, Medium-Weight and Normal-Weight Grout-Filled CMU – 40' BLDG – Risk Cat. II – Exposure C

Anchor Size (Select Any Below)	Minimum Embedment	Minimum Edge Distance
3/8" Titen HD anchors	3 – 3/4"	12"
3/8" Strong-Tie Strong Bolt	2"	12"
3/8" Hilti KWIK Bolt TZ	2 – 5/16"	12"
3/8" Heavy Duty Tapcon	2 – 1/2"	12"
5/16" Heavy Duty Tapcon	1 – 3/4"	12"

Wood, $G = 0.42$ Min., $C_d = 1.6$ – 15' BLDG – Risk Cat. II – Exposure C

Anchor Size	Minimum Embedment	Minimum Edge Distance	Minimum End Distance
3/8" LAG Screw	2 – 1/2"	5/8" into side grain	1 – 1/2"

ACB – LOAD TRANSFER CALCULATIONS TO SUPPORTING STRUCTURE (MAX WIND EFFECT)

The maximum pullout requirement (per anchor) is 1150 lbs. and the maximum shear requirement (per anchor) is 420 lbs. for any of the four (4) ACB Wall bracket systems covered in this document. 117.1 PSF Max. Wind Pressure, 600 lb. Max. Condenser Payload, S.F. = 2.0

UNLESS OTHERWISE SPECIFIED:
 DIMENSIONS ARE IN INCHES [MILLIMETERS]
 TOLERANCES ARE: ANGLES $\pm 1.0^\circ$
 FRACTIONAL SIZES X/Y $\pm 1/64$

INCHES	[MILLIMETERS]
X = ± 0.1	[X = ± 2.5]
XX = ± 0.01	[X = ± 1.3]
XXX = ± 0.005	[XX = ± 0.13]



CONFIDENTIAL - PROPRIETARY - DO NOT COPY THE INFORMATION SET FORTH IN THIS DOCUMENT AND RELATED INFORMATION IS THE CONFIDENTIAL PROPERTY OF DIVERSiTECH CORPORATION, AND IS NOT TO BE COPIED OR REPRODUCED OR DISTRIBUTED IN ANY FORM WITHOUT PRIOR WRITTEN PERMISSION FROM DIVERSiTECH CORPORATION. DO NOT SCALE DRAWING	MATERIAL: AISI 1045 Steel / $S_y \geq 59$ ksi	REV A
	DWG. NO. A/C Condensing Unit Wall Bracket Systems	28AUG17
DESCRIPTION Models: ACB-30, ACB-36, ACB-42 & ACB-48	SHEET 4 OF 5	

ACB Wall Mounting Bracket

Installation Instructions – Professional Installation Required

1. Ensure that the supporting wall structure that the bracket will be mounted on is capable of supporting the weight of the air conditioner unit and bracket and can support the anchor loads as indicated on the ACB specification sheet. (PG-4)
2. Use the correct size wall mounting bracket (ACB-30, ACB-36, ACB-42 & ACB-48) to match up with the condenser unit size. Allow for a minimum of 6in. clearance or the manufacturers recommended distance between the wall and the condenser.
3. Use the holes in the vertical face of the wall mounting bracket to attach it to the wall. Three (3) anchors per bracket are required). Use appropriate anchor size and type as found in the specification sheet for the type of building structure and building height.
4. Install DiversiTech anti-vibration pads (not included) between the condenser unit and the mounting bracket to reduce noise and vibration.

UNLESS OTHERWISE SPECIFIED:
 DIMENSIONS ARE IN INCHES [MILLIMETERS]
 TOLERANCES ARE: ANGLES ±1.0°
 FRACTIONAL SIZES X/Y ±1/64

INCHES	[MILLIMETERS]
X = ±0.1	[X = ± 2.5]
XX = ±0.01	[X = ± 1.3]
XXX = ±0.005	[XX = ±0.13]



THIRD ANGLE PROJECTION



CONFIDENTIAL - PROPRIETARY - DO NOT COPY
 THE INFORMATION SET FORTH IN THIS DOCUMENT AND RELATED INFORMATION IS THE CONFIDENTIAL PROPERTY OF DIVERSITECH CORPORATION, AND IS NOT TO BE COPIED OR REPRODUCED OR DISTRIBUTED IN ANY FORM WITHOUT PRIOR WRITTEN PERMISSION FROM DIVERSITECH CORPORATION.
DO NOT SCALE DRAWING

MATERIAL: AISI 1045 Steel / Sy >= 59ksi
 DWG. NO. A/C Compressor Wall Bracket Units
 DESCRIPTION Models: ACB-30, 36, 42, 48 & QSWB2000 & QSWB4000

REV **A**
 28AUG17
 SHEET 5 OF 5