



# Electronic Exposed TECK® II Flush Valves (with Wallmount H2Optics®)

Record model number:

**81T2 1 -WMSHWA**

**Valve Type**  
0 = W/C (Water Closet)  
3 = Urinal

**Valve Type**  
(leave blank if not applicable)  
1 = V/B Tube w/Tee Assy  
(W/C only)

**Alternate Flush Volumes**  
(leave blank if not applicable)  
48 = 4.8 L (1.27 gal) fixed flush (W/C only)  
42 = 4.2 L (1.1 gal) fixed flush (W/C only)  
19 = 1.9 L (0.5 gal) fixed flush (Urinal only)  
05 = 0.5 L (0.125 gal) fixed flush (Urinal only)

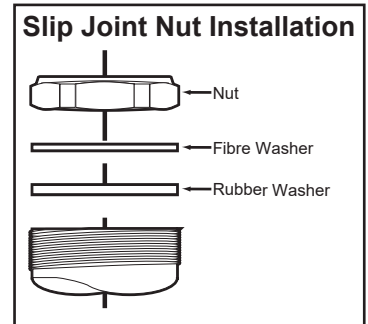
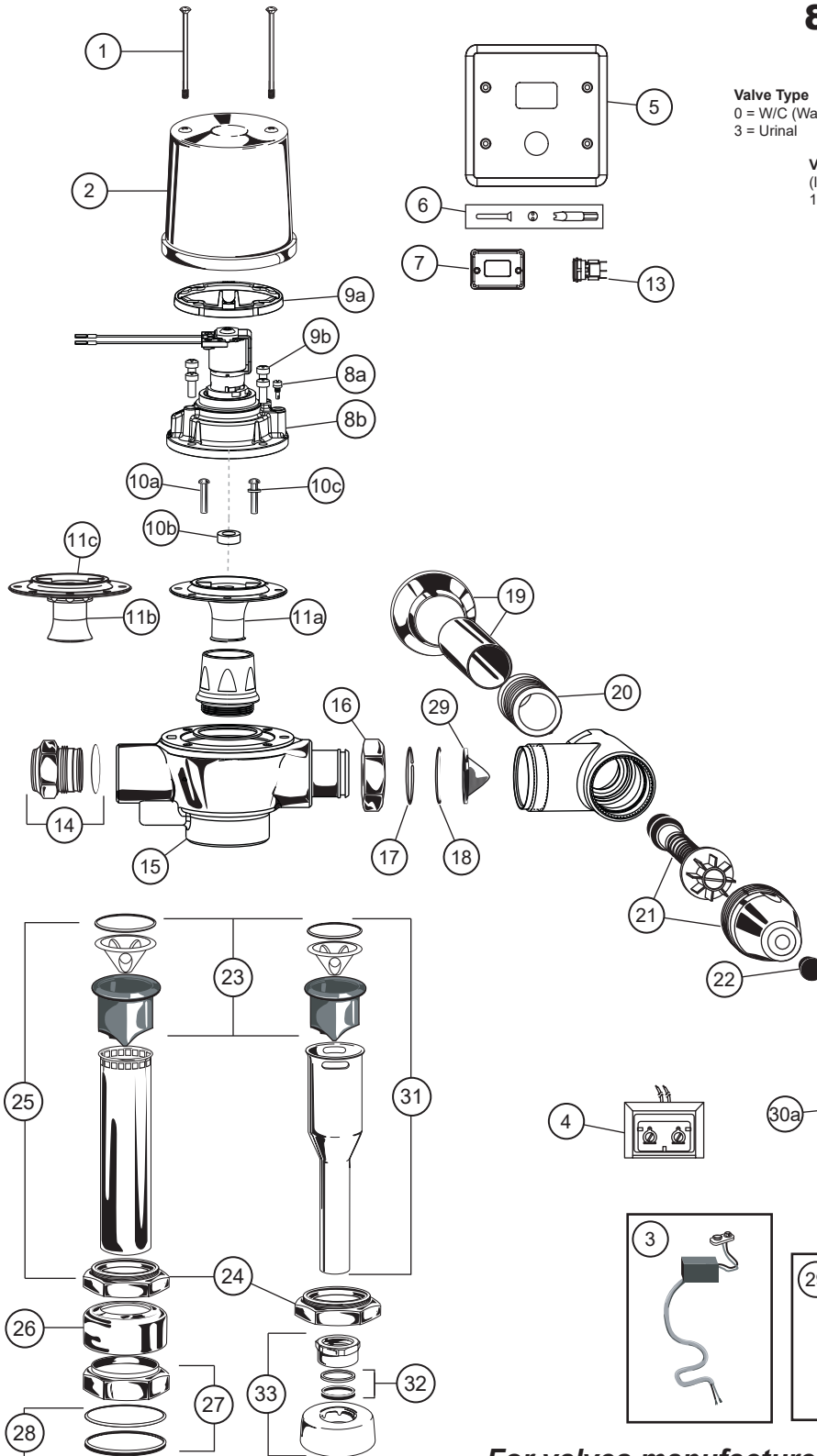

*For valves manufactured  
after October 2014.*

**PLEASE LEAVE this M&I Sheet with the owner, maintenance plumber, etc. as items relating to ongoing maintenance suggestions and procedures are included.**

Item #	Part #	Description
1	060898A	Cover Screws and Driver Bit
2	061275A**	Metal Cover & Screws
3	060683A	24VAC to 6VDC Converter****
4	060704A****	Transformer (110 to 24 VAC) for 5 sensor modules
	060771A****	Transformer (110 to 24 VAC) for 10 sensor module
5	061227A	4-1/2" x 4-1/2" (114 mm x 114 mm) (shown) Stainless Steel Cover with Studs & Screws
6	060072A*	No.6 - 32 x 2" flat head Stainless Steel Screws & Security Spanner Bit package for 4-1/2" (114 mm) Cover (4/pkg)
7	061273A**	Sensor Module - Urinal Flush Valve
	061272A**	Sensor Module - Water Closet Flush Valve
8a	061024A	Regulating Screw & O-Ring
8b	061341A	Cap/Solenoid & Regulating Screw Assembly for 0.5L (0.125 gal) fixed urinals (see Table 1)
	061342A	Cap/Solenoid & Regulating Screw Assembly for 1.9L (0.5 gal) fixed urinals (see Table 1)
	061343A	Cap/Solenoid & Regulating Screw Assembly for 4.2L (1.1 gal) fixed water closets (see Table 1)
	061344A	Cap/Solenoid & Regulating Screw Assembly for 4.8L (1.27 gal) fixed water closets (see Table 1)
	061346A	Cap/Solenoid & Regulating Screw Assembly for 1.9L (0.5 gal) adjustable urinals (see Table 1)
	061169A	Cap/Solenoid & Regulating Screw Assembly for 6.0L (1.6 gal) adjustable water closets (see Table 1)
9a	061141A*	Cover Gasket (3/pkg)
9b	060078A*	Screws for Cast Cap (4/pkg)
10a	060507A***	Poppet Pin Pack (3/pkg) (see Table 1)
10b	062025A***	Washer (3/pkg) (required for 4.8 Valves only) (see Table 1)
10c	060508A***	Poppet Pin Pack (3/pkg) (0.5L Valves only) (see Table 1)
11a	061323A***	Diaphragm/Guide Assembly Complete - W/C (see Table 1)
11b	061324A***	Diaphragm Guide Assembly for Urinals (See Table 1)
11c	060079A-MMO*	Diaphragm only (12/pkg)
12	062007A***	Brass Seat with O-Ring
13	060679A	Electronic Override Button Assembly
14	060342A	Plug and O-Ring for Handle End
15	060506A	Standard Adjustable Tail
16	060735A	Union Nut
17	060692A	Retaining Ring
18	060082A*	Adjustable Tail O-Ring Package (20/pkg)
19	060504A	S/S Wall Flange and Cover Tube
20	060697A	1" (25 mm) Copper Sweat Inlet Adaptor
	060694A	3/4" (19 mm) Copper Sweat Inlet Adaptor
	060764A	3/4" (19 mm) FIP Inlet Adaptor
21	060843A	Retrofit Check Stem Unit, Capnut & Button Complete
	060844A	Seat Washer, Spring, Button and O-Ring Kit
	060859A	Angle Stop with Union Nut and Tail Complete
22	060081A*	Plug Button Package (12/pkg)
23	060785A	VB Sleeve Complete
24	060094A	CP Male Threaded Coupling Ring
25	060782A	1-1/2" x 10" (38 mm x 254 mm) VB, Ring & Tube Complete (for 81T201)
26	060004A	1-1/2" (38 mm) Spud Flange
27	060778A	1-1/2" (38 mm) Rough Coupling Nut and Washer
28	060083A*	1-1/2" (38 mm) Rubber Slip Joint Washers (12/pkg)
29	060344A*	Filter Screen Kit (12/pkg)
30a	060901A	12" (305 mm) Solenoid Extension Cord
30b	060902A	36" (914 mm) Solenoid Extension Cord
31	060784A	3/4" x 11-1/2" (19 mm x 292 mm) VB, Ring & Tube Complete (for 81T231)
32	060049A*	3/4" (19 mm) Rubber and Fibre Slip Joint Washers (12/pkg)
33	060463A	3/4" (19 mm) Polished Chrome Coupling Nut, 3/4" Washer & 3/4" Spud Flange

**NOTE:** Refer to TECK flushometer repair parts and maintenance manual for additional parts and information.







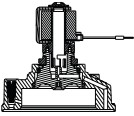

\* Package quantities may change. Check the parts section of the latest Delta Commercial Faucet Price List for current quantities.

\*\* For valves manufactured before October 2014, you must replace the sensor module, cap/solenoid, chrome cover and gasket which are included in; UR Kit - 061280A or WC Kit - 061281A. See Table on page 1 to determine appropriate poppet pin & diaphragm repair parts based on the flush volume required.

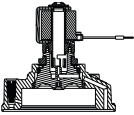
\*\*\* For valves manufactured before January 2013, you must replace the sensor module, cap/solenoid, chrome cover and gasket, diaphragm assembly and the brass seat with O-ring which are included in; UR Kit - 061282A or WC Kit - 061283A. See Table on page 1 to determine appropriate poppet pin & diaphragm repair parts based on the flush volume required.

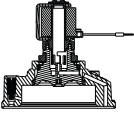
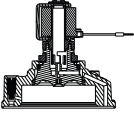
\*\*\*\* Each individual sensor module requires its own 24 VAC to 6 VDC hardwire converter.

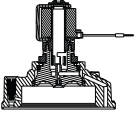
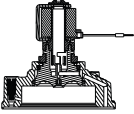
### Table 1 - Cap/Pin/Diaphragm Configuration Table

	Flush Volume	Cap/Solenoid & Regulating Screw Assembly (includes Cap, Solenoid, Regulating Screw)	Poppet Pin	Diaphragm Assembly
*UR - Fixed	**0.5L (0.125 gal)	061341A 	060508A 	
	**1.9L (0.5 gal)	061342A 	060507A 	
UR - Adjustable	1.9L (0.5 gal)	061346A 		
W/C - Fixed	**4.2L (1.1 gal)	061343A 	060507A & 062025A 	
	**4.8L (1.27 gal)	061344A 		
W/C - Adjustable	6.0L (1.6 gal)	061169A 	060507A & 062025A 	

**NOTE: Must use all noted components listed in Table 1 to ensure correct flush volumes.**

\* Fixed models have epoxy in the adjustment screw.

\*\* WaterSense® compliant when paired with a WaterSense fixture rated for the same flush volume.

Product #	A	B	C
	Max.	±11mm (7/16")	Min.
81T201-WMSHWA	292mm (11½")	121mm (4¾")	54mm (2.13")
81T231-WMSHWA	330mm (13")	121mm (4¾")	54mm (2.13")

Flushometer **MUST** be paired with a fixture of equivalent flush volume.

## BEFORE THE FIRST FLUSH (COMPLETE VALVES)

### RECOMMENDED WATER SUPPLY:

W/C - minimum flowing pressure: 25 psi (172 kPa),  
minimum flow rate: 25 gpm (95 lpm)

UR - minimum flowing pressure: 25 psi (172 kPa),  
minimum flow rate: 8 gpm (30 lpm)

The 1.1 GPF (4.2L) valve is recommended for new construction only.

### FLUSH BOTH OLD AND NEW PIPES:

It is important to FLUSH and thoroughly CLEAN both new and old water piping to ELIMINATE contaminants (eg. scale, sediment, gravel, cuttings, solder, etc.) from the line.

Where the water has a sediment content, a PIPE STRAINER in the supply line should alleviate that condition and protect working parts of flushometers and faucets.

On a NEW INSTALLATION, always flush the valve 4 or 5 times to clean out supply line debris. It is also advisable where more than one flushometer is installed on a water line, to flush out the water piping through the last flushometer outlet of the pipe line.

### INSTALL FILTER SCREEN (included):

**Note:** Place filter in stop bore with conical screen facing the water flow.

**Caution:** Do not push filter in too far. Let filter seat against face of flush valve tail. Periodic cleaning of the filter screen with water is recommended depending on local water conditions to remove any dirt or sediment. See filter screen M&I for additional installation information.

### ELIMINATE AIR FROM VALVES:

The FIRST FLUSH should ELIMINATE all air from the TECK flushometer. DO NOT ADJUST flushometer based on the results of the first flush.

### TO PREVENT WATER HAMMER:

A water hammer arrestor may be installed at the last flushometer and/or at the back of an individual installation. This assures SMOOTHER OPERATION of the valves and longer life for the working parts.

HANDS SHOULD BE CLEAN AND FREE OF GREASE AND OIL during any maintenance or handling of electronic housing components to prevent possible damage to internal circuitry.

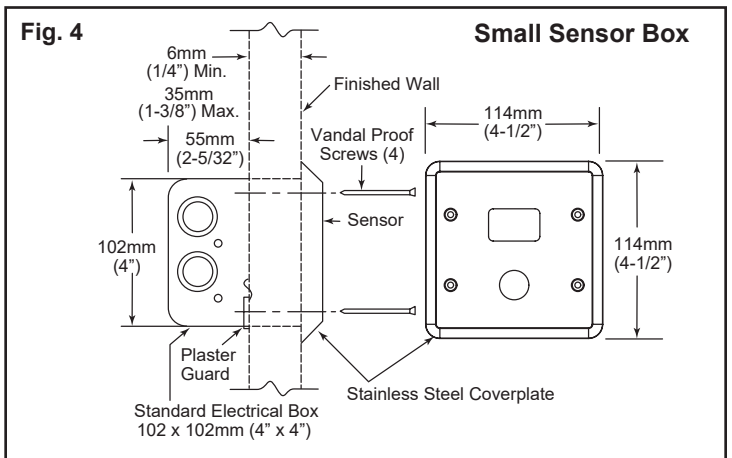
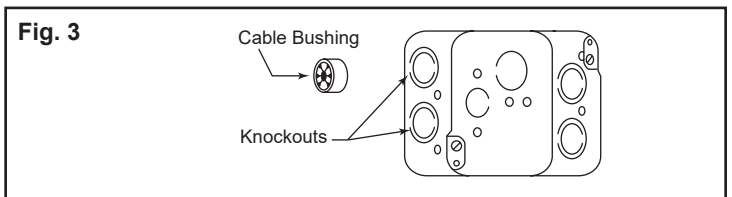
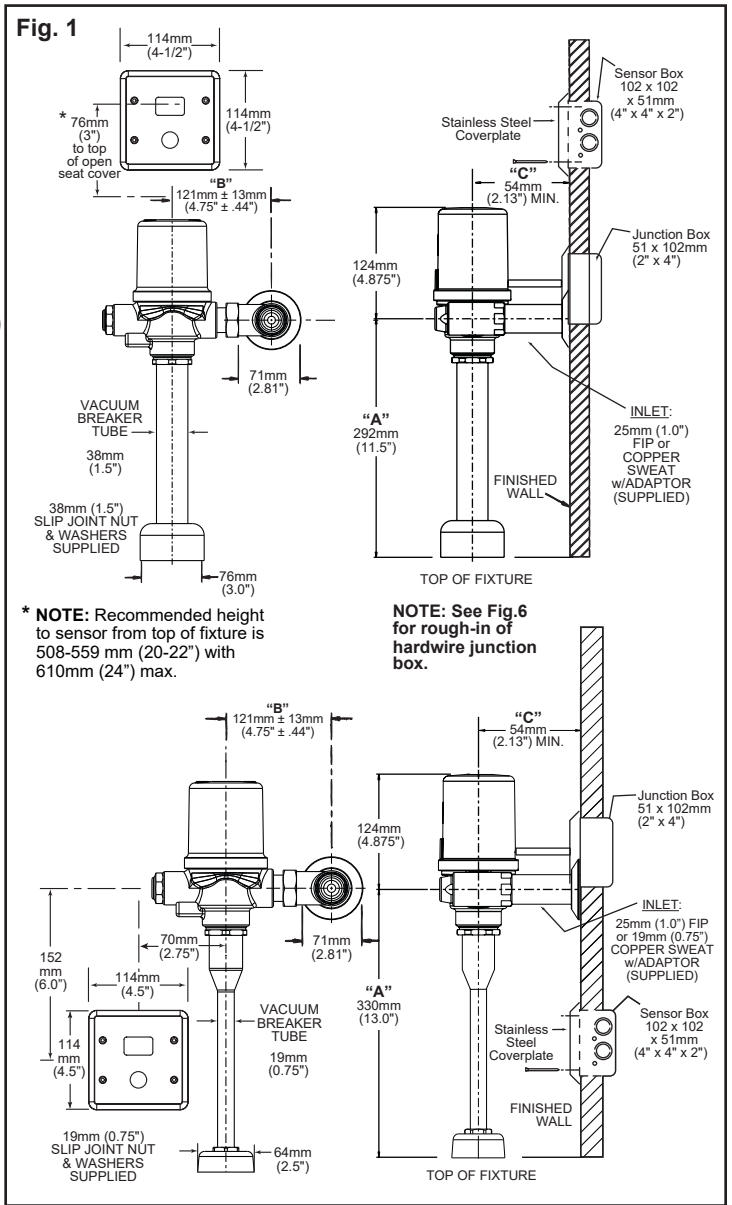
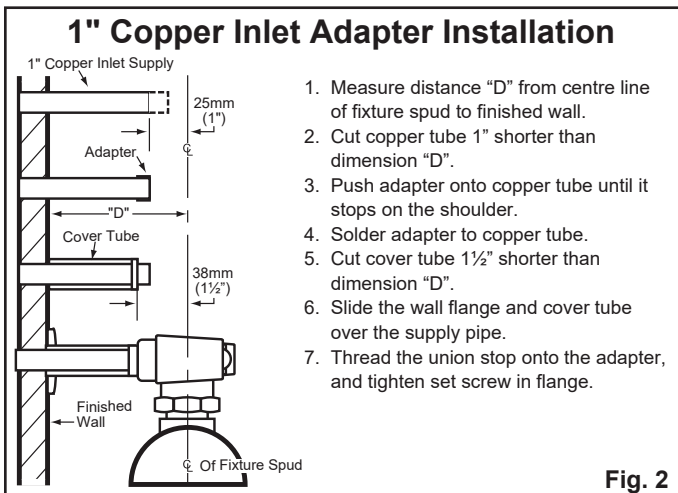

# INSTALLATION INSTRUCTIONS

## STEP 1 - ROUGH-IN FLUSH VALVE

- Install and attach flush valve to water supply as per Fig. 2.

## STEP 2 - ROUGH-IN SENSOR BOX

### If Hardwire Operated

- 102mm (4") box is supplied, remove suitable knockouts and insert cable bushing as per Fig. 3.
- Rough-in box for sensor location as per Fig. 6. Note: Solenoid extension cord supplied with trim is 915mm (36") long.
- Securely attach box to wall structure.
- Install CSA and/or UL approved Class 2 transformer or equivalent in a convenient location or in a pipe chase. (**Do NOT install the transformer inside the control box.**)
- Run suitable wire from 24VAC power source into box. Use wire which complies with local electrical codes for 1 amp load. No.18 cable is usually sufficient.
- Attached supplied plasterguard as per Fig. 4 to ensure sensor mounting holes are positioned correctly.

## STEP 3 - ROUGH-IN JUNCTION BOX

- Rough-in 2X4 junction box as per Fig.6.

## STEP 4 - INSTALL SENSOR PLATE AND TUBE ASSEMBLY

### If Hardwire Operated

- Attach hardwire converter supplied to the 24VAC power source using the wire nuts provided.
- Attach converter to the sensor module using the snap connector.
- Using the 915mm (36") solenoid extension cord supplied, attach the male tabs to the sensor module and then run the wire down to the 2X4 rough-in box located behind the flush valve.
- Using the 25.4mm (12") solenoid extension cord supplied, attach the female connectors to the solenoid valve on the flush valve cap.
- Feed the free end of the wire through the tube assembly.
- Feed the tube assembly and wire through the bushing on the 2X4 plate and into the rough-in box located behind the flush valve.
- Attach the wires to the extension cord which was run down from the sensor. Make sure to correctly match the wire colours on both extension cords.
- Secure 2X4 stainless steel plate with bushing to the junction box.
- Assemble cover onto flush valve cap and attach using 2 vandal proof screws provided. Ensure the tube assembly is aligned with the slot in the back of the cover.
- If the factory default settings for the sensor are not suitable, refer to Step 6 for sensor adjustments.
- Attach sensor plate to the box using the 4 vandal proof screws provided.

Fig. 5

### Solenoid Extension Cords

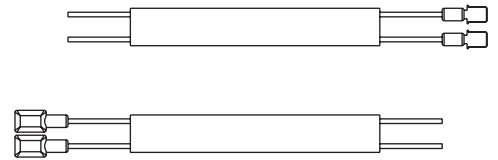

## STEP 5 - OPERATION MODE

A sequence of red lights that strobe across the sensing lens window will signify that the valve is now in operation mode. Once in operation mode, if factory settings are preferred, no further action is required and the valve installation is complete.

### Factory pre-set functions are:

Water closet bowl length of 40", 24 hour flush is off and flush delay is 4 seconds.  
Urinal sensing distance of 20", 24 hour flush is off and no flush delay.

Once in operation mode, if adjustments are preferred, installer must move into set up mode (see Step 6).

## FUNCTION AND TROUBLESHOOTING LIGHTS

### HARDWIRE VERSION: NO LIGHTS-NO POWER

Check that the 24VAC transformer has power on the incoming 120VAC side. (Transformer breaker is turned on.)

Check the connection of the flushometer wires to 24VAC transformer.

Check that the connection of the hardwire converter is made to the electronic board within the electronic flush valve housing.

For further technical assistance, call Delta Commercial Technical Service at 1-800-387-8277 (Canada) or 1-877-509-2680 (U.S.A.).

### Electronic Override Button in Operating Mode:

BLUE light flashes once when Electronic Override Button is activated. Should the electronic override button stick, the program will continue to operate and will reset automatically if the electronic override button is repaired or it returns to home position.

Fig. 6

## Hardwire Junction Box and Sensor Rough-In (See Fig. 1 for placement of inlet stop.)

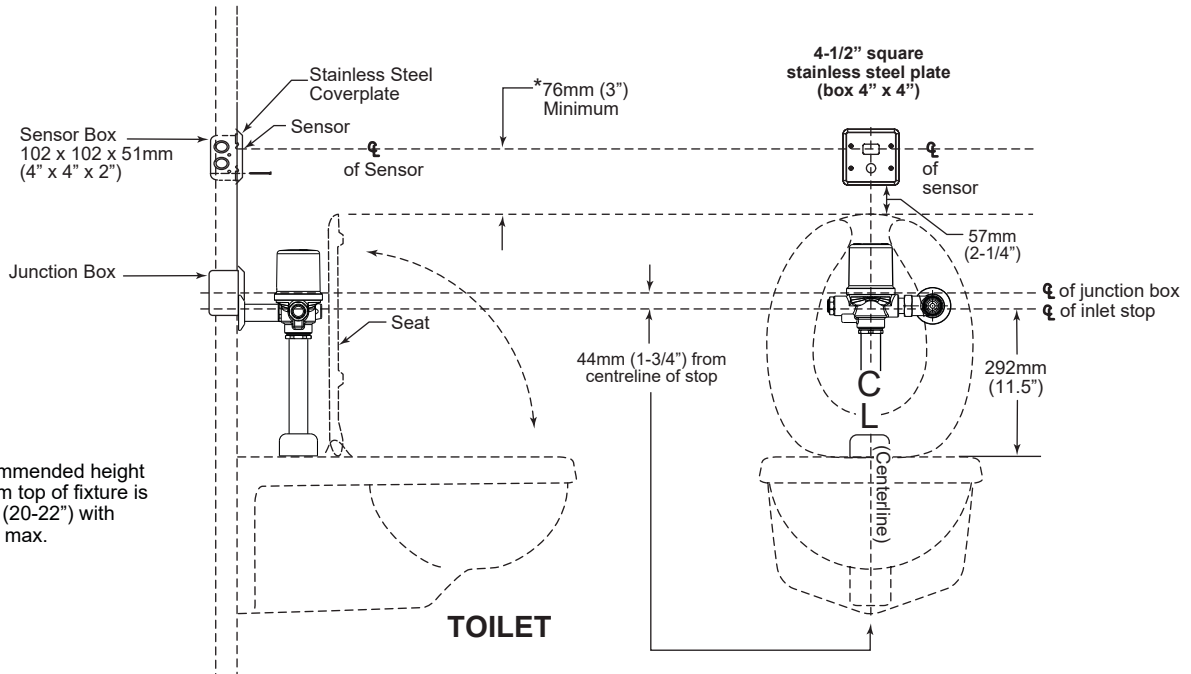

\* **NOTE:** Recommended height to sensor from top of fixture is 508-559 mm (20-22") with 610mm (24") max.

**NOTE:** Hardwire junction box installed behind flush valve on centerline of fixture.

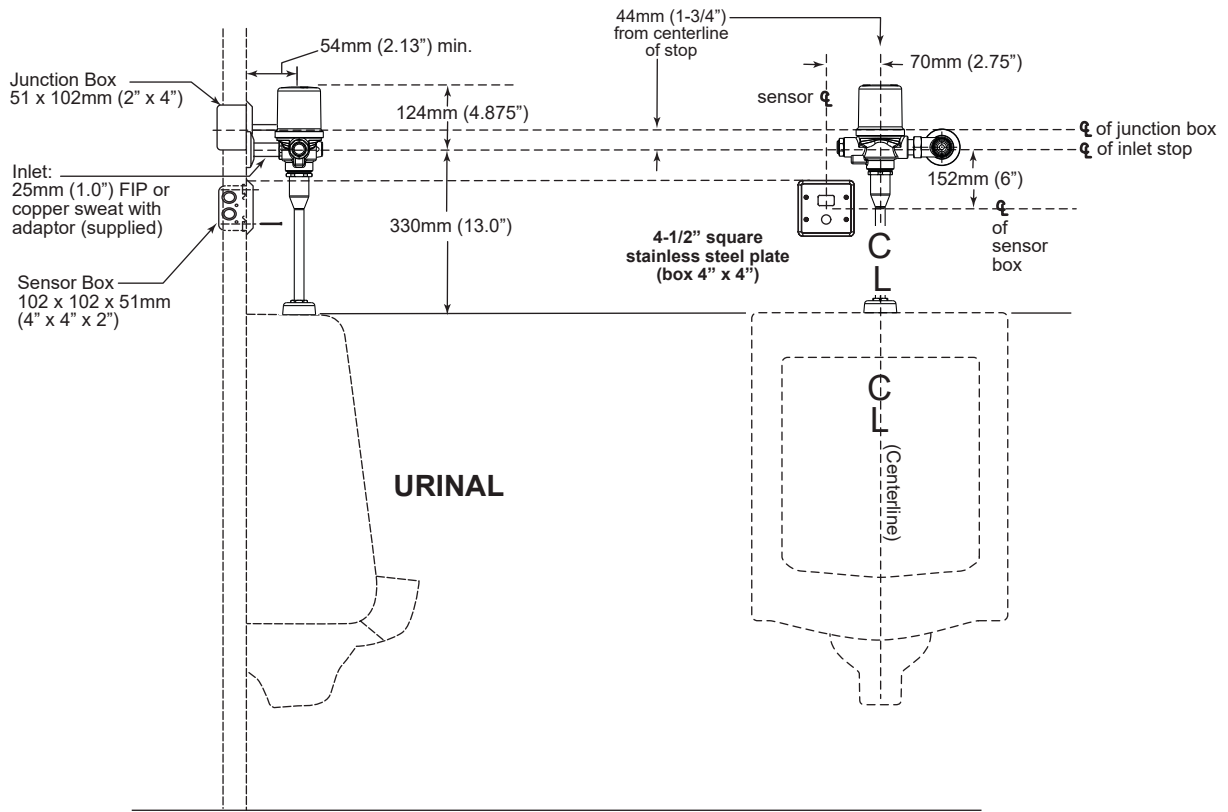

Product Supplied as Shown by Solid Lines.  
All Items Shown by Dotted Lines Supplied by Others.

# STEP 6 - MAKING ADJUSTMENTS

(Optional: Only required if factory settings are not preferred.)

- To move from operation mode into set-up mode: remove the plastic plug located in the rear of the sensor module and press the set-up mode button once. A pencil or small screwdriver may be required. When done, place the plug back in the hole.

## 6.1 Adjusting Sensing Distances:

- Sequences of red lights will intermittently strobe across the sensor window, followed by a number of red lights which stay on to indicate the current sensing distance.

Pre-set sensing distances are:

Water Closet		Urinal	
1 light	24"	1 light	12"
2 lights	32"	2 lights	16"
3 lights	40" (factory set)	3 lights	20" (factory set)
4 lights	48"	4 lights	24"
5 lights	56"	5 lights	28"

- A pulsating blue light on the far left of the sensor window will indicate if an object is detected. However, the sensing distance could be set at a distance greater or shorter than the desired activating position.
- To ensure sensing distance is set to precise desired position, stand at desired activating distance.
- If the pulsating blue light is not present, press the override button (the red lights will increment).
- Continuing to press the override button will eventually loop the sensing distance back to 1 light (12" sensing distance for urinal, 24" sensing distance for water closet).
- Press override button until pulsating blue light is present. The blue light indicates that the sensing distance has been adjusted to a position that is detecting you.

### Water closet only:

- Now stand back and ensure that the pulsating blue light disappears when you stand near the door of the water closet.
- Ensure that the door is not being detected as well. If so, decrease the range increment by 1 light (this is achieved by pressing the override button until the lights loop back around to a setting that is one less the previous setting).
- Once again, verify that the sensor is not detecting the water closet door. If not, the sensor is now set at your desired position.
- The sensing distance for water closets can be set between 24" and 56", and for urinals between 12" and 28".
- If all adjustments have been completed, press and hold down the manual override button for 5 seconds. For water closets; this will return the valve to operation mode. For urinals; this will advance the distance adjustment mode into the 24 Hour Flush adjustment mode.

### 6.2 Adjusting 24 Hour Flush (for Urinal applications):

- When 3 red lights in the centre of the sensor window are on, 24 hour flush is on.
- When the red light in the middle of the 3 lights is off, the 24 hour flush is off.
- Press manual override button to toggle between on and off mode.
- If all adjustments have been completed, press and hold down the manual override button for 5 seconds until all lights go out.

### Factory Settings:

Flush volume adjustment:

#### Not Adjustable

1.27 U.S. gallons / 4.8 litres for water closets  
 1.1 U.S. gallons / 4.2 litres for water closets  
 0.5 U.S. gallons / 1.9 litres for urinal valves  
 0.125 U.S. gallons / 0.5 litre for urinal valves

#### Adjustable

1.6 U.S. gallons / 6 litres for water closets  
 0.5 U.S. gallons / 1.9 litres for urinal valves

The Regulating Screw (061024A, item #9) may be adjusted, according to job conditions and fixture installed to the proper water volume to flush that particular fixture (except -48, -42, -19 and -05 models which are not field adjustable).

**Note:** Water closets or washdown urinals may require the Angle Stop to be set at only ONE TURN OPEN. For a SHORTER flush, turn the regulating screw (061024A, item #9) left (counter-clockwise) and right (clockwise) for a LONGER flush (except -48, -42, -19 and -05 models which are not field adjustable).

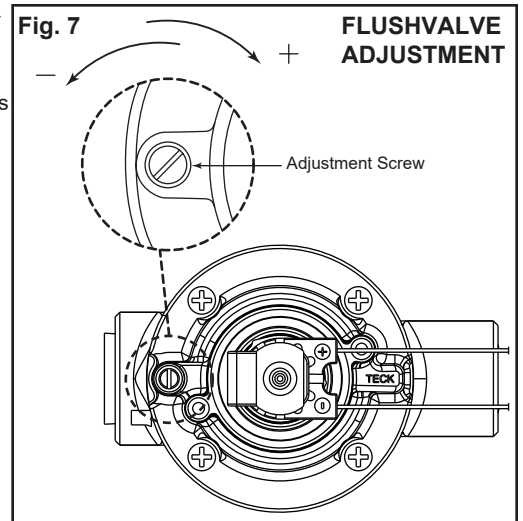

# PROBLEM SOLVING & MAINTENANCE SUGGESTIONS

**NOTE:** DO NOT USE EXCESSIVE FORCE to close the inlet stop stem. We RECOMMEND that the flushometer be flushed while closing the inlet stop. The noise created by the water flow or the flow into the fixture will stop when the inlet water is shut off.

**NOTE:** Always use DELTA COMMERCIAL GENUINE PARTS to maintain the warranty.

## EXCESSIVE NOISE:

1. PARTIALLY close the inlet stop.
2. Pressures OVER 75 PSI may lead to an increase in NOISE, water could SPLASH out of the fixture more easily and the LIFE of any plumbing valve may be SHORTENED.
3. INSTALL a Pressure Reducing Valve set at a lower pressure if actual pressure is over 75 PSI. While the TECK Flushometer will operate up to 125 PSI, the preferred operating range is between 35 to 65 PSI.
4. On flushometers that have been installed for a number of years, check the Renewable Seat (062007A, item #12) for wear and replace if necessary.

## EXCESSIVE WATER FLOW RATE:

1. OPEN inlet stop ONE TURN and adjust Regulating Screw (061024A, item #7a) to the fixture requirement (except on -19, -05, -42 and -48 models which are fixed volume).
2. Operation of flushometer with inlet stop BELOW ONE TURN OPEN may cause EXCESSIVE NOISE. The lowest open setting for the inlet stop may vary dependent on the installation.

## SHORTAGE OF WATER TO PROPERLY FLUSH BOWL:

1. OPEN inlet stop fully.
2. CHECK pipeline for size or obstruction, partially closed gate or other supply line valve, corroded or undersize water piping.
3. CHECK water pressure.
4. Water flow rate is determined by BOTH the water pipe size AND the water pressure available.
5. A water closet flush valve requires a minimum water supply of 1" (or larger), depending on a number of different factors including water pressure (PSI) available, pipe size and length of pipe run, number of fixtures per washroom and per building, fixture type, fixture usage factor, elevation of valve above the water main, etc. We strongly recommend that pipe size calculations be done to insure proper water supply sizes.

Flushometers do NOT provide a water supply; they are merely automatically timed self-closing valves. The inlet supply piping is the water reservoir that must supply sufficient water volume in a short period of time (4 to 10 seconds) to properly flush and clear the fixture.

## CONTINUOUS FLUSHING:

1. The Regulating Screw (061024A, item #8a) may be turned RIGHT (clockwise) TOO FAR. Adjust by slowly turning the Regulating Screw LEFT (counter-clockwise) (except -48, -42, -19 and -05 models which are fixed volume).
2. If flush is still continuous, close inlet stop, remove Regulating Screw (061024A, item #8a), CLEAN bypass slot in the screw, REPLACE it in the valve and ADJUST slowly for proper flush (except -48, -42, -19 and -05 models which are fixed volume).
3. Remove cap assembly (item #7b) and Diaphragm/Guide Assembly (061323A - W/C item #11a or 061324A - UR item #11b), check for contaminants at renewable seat (Item #12) and diaphragm and check for debris in the cap for blockage. Also CHECK that the Diaphragm/Guide slides easily in the Renewable Seat.

## VALVE WILL NOT FLUSH:

1. When the valve has been taken apart for servicing and re-assembled and does NOT operate, check that the Cap has been put on the body properly. The Regulating Screw (061024A, item #8a) should always be on the same side as the inlet stop.
2. When all lights operate as expected but valve will not flush, check that the solenoid makes a clicking sound. If no clicking sound is present, then replace with Cap Assembly (061169A, item #8b).
3. After a number of years, the valve will flush but shuts off immediately when activated. The Diaphragm (060079A-MMO, item #11c) is worn or split and needs replacing.

## SLIGHT WATER LEAK INTO FIXTURE:

1. EXAMINE the seating surface of the Diaphragm (060079A-MMO, item #11c) for imbedded sediment.

# CLEANING INSTRUCTIONS

CLEAN the outside of the chrome plated flushometer with a damp cloth.

**CAUTION:** MOST Tub & Tile fixture cleaners contain ACIDS. DO NOT WIPE the cloth used to clean ceramic fixtures over the flushometer as it will remove the chrome plating and leave a discoloured surface.

## Limited Warranty on Delta® Commercial Products

### Parts and Finish

All parts (including electronic parts other than batteries) and finishes of this Delta® commercial product are warranted to the original purchaser to be free from defects in material and workmanship for five (5) years from the date of purchase. No warranty is provided on batteries. Special terms and conditions may apply for specific models. Please refer to the Model Specification Sheet for more details.

### What We Will Do

Masco Canada Limited will repair or replace, free of charge, during the applicable warranty period (as described above), any part or finish that proves defective in material and/or workmanship under normal installation, use and service. If repair or replacement is not practical, Masco Canada Limited may elect to refund the purchase price in exchange for the return of the product. **These are your exclusive remedies.**

### What Is Not Covered

Any labor charges incurred by the purchaser to repair, replace, install or remove this product are not covered by this warranty. Masco Canada Limited shall not be liable for any damage to the commercial product resulting from reasonable wear and tear, misuse, abuse, neglect, changing building conditions (such as voltage spikes), aggressive waters for sterilization, gray water (recycled or repurposed water for toilet usage), improper or incorrectly performed installation, maintenance or repair, including failure to follow the applicable care and cleaning instructions, and any other exclusions set forth in the Maintenance and Installation manual for the particular product. Masco Canada Limited recommends using a professional plumber for all installation and repair. We also recommend that you use only genuine Delta® replacement parts.

### What You Must Do To Obtain Warranty Service Or Replacement Parts

A warranty claim may be made and replacement parts may be obtained by calling or writing as follows:

#### In the United States and Mexico:

Delta Faucet Company  
55 E. 111th Street  
Indianapolis, IN 46280  
Attention: Warranty Service  
[www.deltafaucet.com/service-parts/contact-us](http://www.deltafaucet.com/service-parts/contact-us)

#### In Canada:

Masco Canada Limited  
Technical Service Centre  
350 South Edgeware Road  
St. Thomas, Ontario N5P 4L1  
<http://www.deltafaucet.ca/customer-support/assistance.html>

Delta® Commercial products covered under this warranty include: Delta Commercial TECK® series, Delta Commercial HDF® series, and Delta Commercial DEMD™ series. This warranty applies only to Delta® Commercial products installed in the United States of America and Canada.

### Limitation on Duration of Implied Warranties.

Please note that some states/provinces (including Quebec) do not allow limitations on how long an implied warranty lasts, so the below limitations may not apply to you. TO THE MAXIMUM EXTENT PERMITTED BY APPLICABLE LAW, ANY IMPLIED WARRANTY OR CONDITION, INCLUDING THE IMPLIED WARRANTIES OF MERCHANTABILITY AND OF FITNESS FOR A PARTICULAR PURPOSE, IS LIMITED TO THE STATUTORY PERIOD OR THE DURATION OF THIS WARRANTY, WHICHEVER IS SHORTER.

### Limitation of Special, Incidental or Consequential Damages.

Please note that some states/provinces (including Quebec) do not allow the exclusion or limitation of special, incidental or consequential damages, so the below limitations and exclusions may not apply to you. TO THE MAXIMUM EXTENT PERMITTED BY APPLICABLE LAW, THIS WARRANTY DOES NOT COVER, AND MASCO CANADA LIMITED SHALL NOT BE LIABLE FOR ANY SPECIAL, INCIDENTAL OR CONSEQUENTIAL DAMAGES (INCLUDING LABOR CHARGES TO REPAIR, REPLACE, INSTALL OR REMOVE THIS PRODUCT), WHETHER ARISING OUT OF BREACH OF ANY EXPRESS OR IMPLIED WARRANTY OR CONDITION, BREACH OF CONTRACT, TORT, OR OTHERWISE. MASCO CANADA LIMITED SHALL NOT BE LIABLE FOR ANY DAMAGE TO THE COMMERCIAL PRODUCT RESULTING FROM REASONABLE WEAR AND TEAR, MISUSE, ABUSE, NEGLIGENCE, CHANGING BUILDING CONDITIONS (SUCH AS VOLTAGE SPIKES), AGGRESSIVE WATERS FOR STERILIZATION, GRAY WATER (RECYCLED OR REPURPOSED WATER FOR TOILET USAGE), IMPROPER OR INCORRECTLY PERFORMED INSTALLATION, MAINTENANCE OR REPAIR, INCLUDING FAILURE TO FOLLOW THE APPLICABLE CARE AND CLEANING INSTRUCTIONS, AND ANY OTHER EXCLUSIONS SET FORTH IN THE MAINTENANCE AND INSTRUCTION MANUAL FOR THE PARTICULAR PRODUCT. Note to residents of the State of New Jersey: The provisions of this document are intended to apply to the fullest extent permitted by the laws of the State of New Jersey.

### Additional Rights

This warranty gives you specific legal rights, and you may also have other rights which vary from state/province to state/province.

This is Masco Canada Limited's exclusive written warranty and the warranty is not transferable.

If you have any questions or concerns regarding our warranty, please call, mail or email us as provided above.

This device complies with Part 15 of the FCC Rules. Operation is subject to the following two conditions:

- (1) this device may not cause harmful interference, and
- (2) this device must accept any interference received, including interference that may cause undesired operation.

**NOTICE** This equipment has been tested and found to comply with the limits for a Class A digital device, pursuant to Part 15 of the FCC Rules. These limits are designed to provide reasonable protection against harmful interference when the equipment is operated in a commercial environment. This equipment generates, uses, and can radiate radio frequency energy and, if not installed and used in accordance with the instruction manual, may cause harmful interference to radio communications. Operation of this equipment in a residential area is likely to cause harmful interference in which case the user will be required to correct the interference at his own expense.

**WARNING** Changes or modifications not expressly approved by the manufacturer could void the user's authority to operate the equipment.

CAN ICES-3 (A) / NMB-3(A)

© 2020 Masco Canada Ltd.

255069 Rev G

For further technical assistance, call Delta Commercial Technical Service at 1-800-387-8277 (Canada) or 1-877-509-2680 (U.S.A.).