

Data Sheet

ESBE CRA122 Setpoint Control

Features:



The ESBE CRA122 is a combined actuator and constant flow temperature control with an adjustable temperature setting. This control is a direct replacement for the 92K2 control. The CRA122 monitors and maintains the setpoint of water or air temperature on mixing or diverting applications by modulating ESBE 3-way or 4-way

valves in the recommended sizes ranging from 2-1/2" to 6". The CRA122 setpoint control can also be used with smaller sized VRG valve bodies with the use of the VRG to Series 90 mounting kit code no. 193B1616.

Benefits:

- Complete control package; actuator, sensor* and controller included *Included sensor is 4.9 ft/1.5m, but optional 16 ft/5 m cable can be purchased (17053100)
- Simple 'keypad' menu and settings
- LCD backlit digital display
- Directly mounted to ESBE valve bodies
- Adjustable setpoint temperature range of 41° to 203°F (5° to 95°C)
- Able to maintain two unique setpoint temperatures (ex: 120°F and 140°F)
- Selectable rotation speed of actuator

Ordering Information:

Code No.	Series	Required Power Supply	Selectable Run Time (90° @ 60Hz)	Designed for Use With
12742212	CRA122	3-point floating	12/25/50/100/200/398 seconds	ESBE (All Valve Sizes)

**Accessories/
Replacement Parts:**

Code No.	Description
193B1615	Replacement actuator mounting kit for MG, G, & F series
193B1616	Actuator mounting kit to ESBE VRG valve
17053100	CRA911 Temperature sensor, 16ft (5m)

Applications:

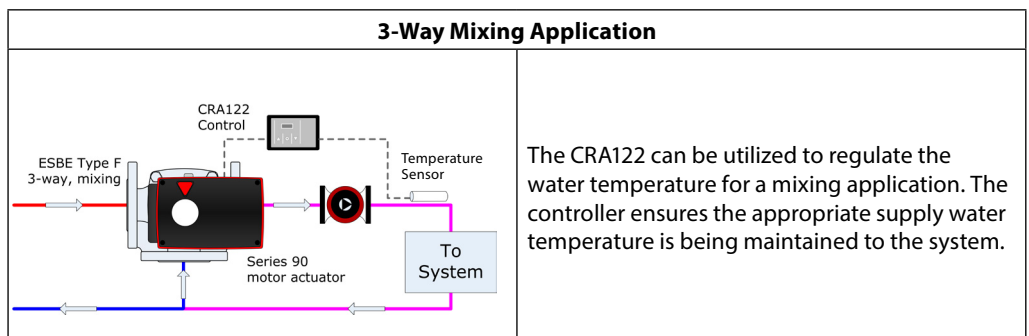

Applications:

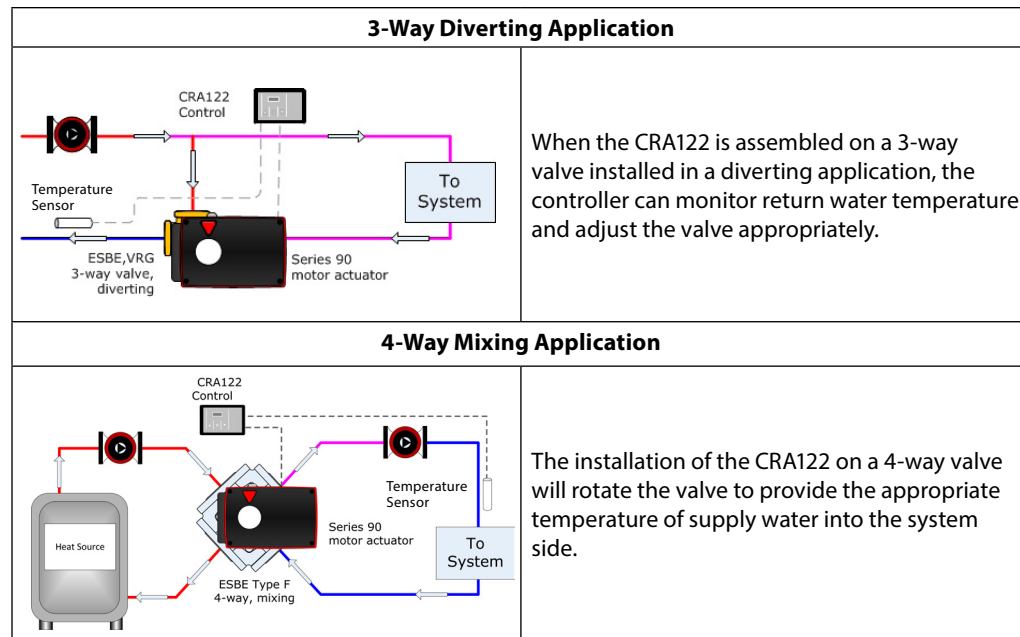

Technical Specifications:

Supply Voltage	24 ± 10% VAC, 50/60 Hz
Power Consumption	3VA
Rotation	90° (factory), adjustable from 30° to 180°
Torque	135 in. lbs (15Nm)
Mountable ESBE Valve Styles Sizes	MG & G series, F series, VRG w/ mounting kit
Enclosure rating (Actuator & Control)	NEMA 13, IP54
Ambient Temperature Range	23° to 131°F (-5° to 55°C)
Adjustable setpoint temperature range	41° to 203°F (5° to 95°C)
Weight	1.9lb (0.9kg)
Run Time	120sec (default), Selectable: @60Hz: 12/25/50/100/200/398 seconds @50 Hz: 15/30/60/120/240/480 seconds

Electrical Wiring:

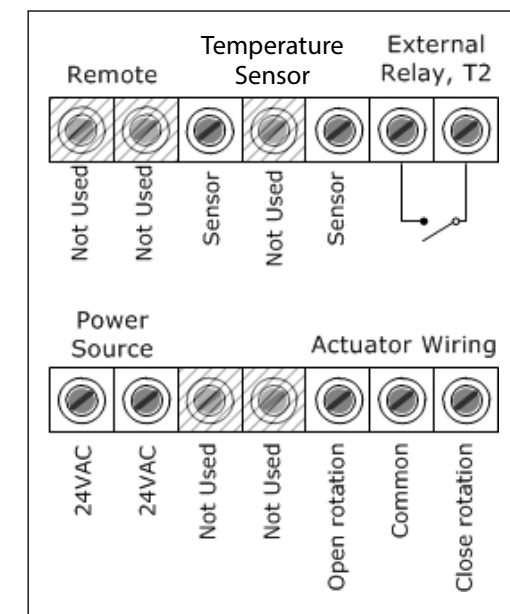

External Relay, T2:

An external relay connected to the T2 terminals on the CRA signals the control to maintain a different setpoint temperature. When the relay is closed the control looks to the T2 temperature setting and overrides the current setting. This external relay can be utilized as a setback or boosting of the setpoint temperature based upon the application requirements.

Installation:

The actuator should be mounted with the valve stem in either a horizontal position or pointing upwards. The actuator should not be installed in a downward orientation.

- 2, 3) Drive sleeve Assembly
- 4) Handle
- 1, 5, 6, 8, 9) Mounting hardware
- 7) Mounting Base
- 10) Mounting Stud

When installing the handle, it should be installed opposite to the indicator on the drive sleeve and the end of the handle should be facing away from the valve. Failure to properly install the handle will result in damage to the 90 series motor actuator due to the interference of the mounting stud with the rotation of the handle

Incorrect handle orientation

Correct handle orientation

Adjustment of Rotation:

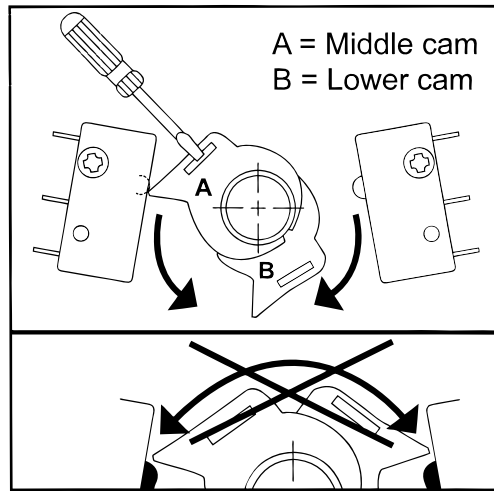

Within the 90 Series actuators, the factory set 90° of rotation can be adjustable between 30° and 180°. The adjustment of the angle of rotation is set via internal cams within the actuator. Care should be taken to ensure the cams are engaging the switches properly.

Manual Operation:

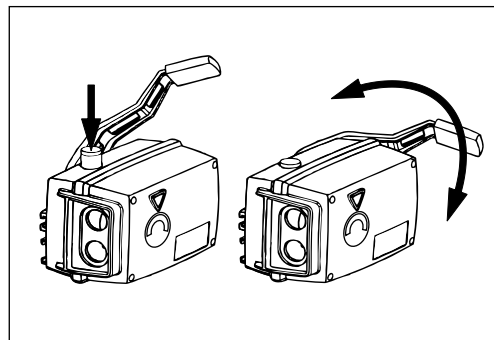

When placing the actuator in manual operation power should be turned off to the actuator. In the event the actuator is powered and is left in a manual position, the result could lead to the internal damage of the actuator.

When placing the 90 Series motor in manual operation, the gray button must be pushed in. Then the handle can be rotated either clockwise or counter clockwise. To return back to automatic operation, rotate the handle until the button pops out.

**Dimensions:
(mm)**

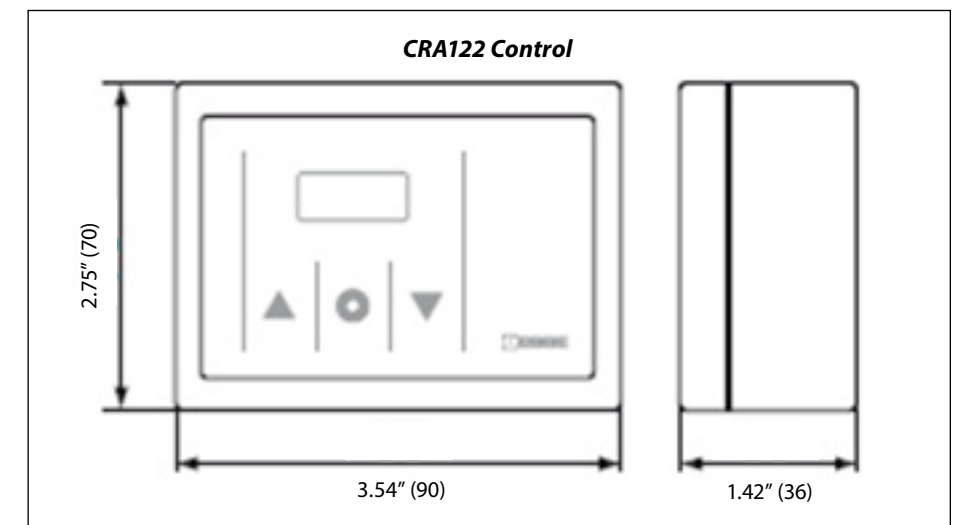
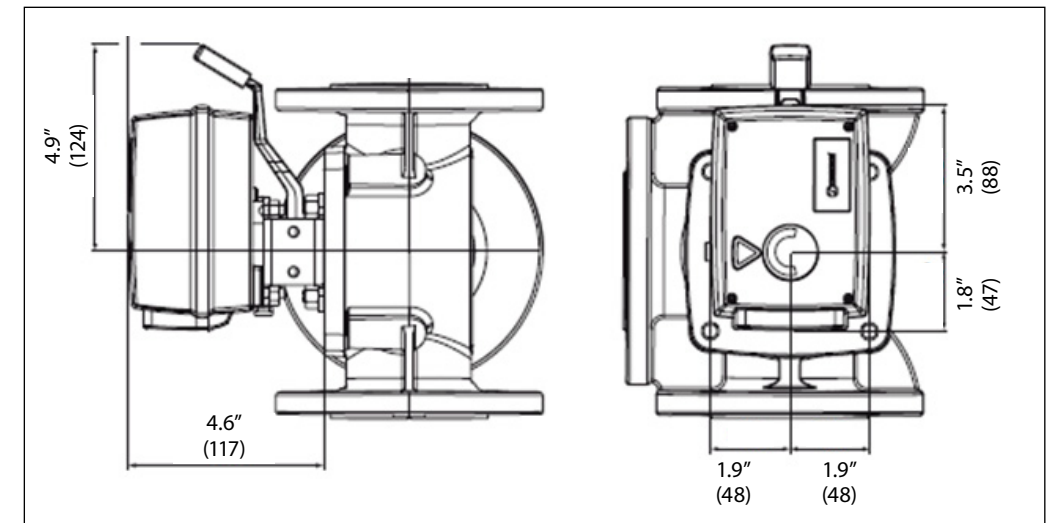

Danfoss can accept no responsibility for possible errors in printed materials and reserves the right to alter its products without notice. All trademarks in this material are property of the respective companies. Danfoss and Danfoss logotype are trademarks of Danfoss A/S. All rights reserved.



Danfoss
Toronto, ON
Tel.: 905-285-2050, Fax: 905-285-2055
www.na.heating.danfoss.com

Danfoss
Baltimore, MD
Tel.: 443-512-0266, Fax: 416-352-5981
www.na.heating.danfoss.com