



Applications:



The ESBE 3 and 4-Way rotary valves type F are designed for mixing or diverting applications on heating and cooling systems. The valves are capable of controlling and distributing water or non-corrosive liquids on closed looped systems to different zones by either manual operation or automatically via electronic motor actuator and controller.

Features:

- The F series of valves are a rotary design allowing for flexibility in field piping layout.

- Double mixing function for 4-Way valve, reducing the risk of condensation within heat source
- Valve position face plate is printed on both sides and can be rotated allowing a choice of valve mounting positions
- Easily adaptable with ESBE electronic motor actuator Series 90
- Suitable fluid of 100% water or glycol mixture (maximum 50% glycol) for heating or cooling closed loop systems.

Ordering Information:

3-Way Valve

Code No.	Reference	Connection	Cv*
065B8960	3 F 65-50	2-1/2" ANSI Flanged	75
065B8961	3 F 65	2-1/2" ANSI Flanged	105
065B8962	3 F 80	3" ANSI Flanged	175
065B8963	3 F 100	4" ANSI Flanged	265
065B8964	3 F 125	5" ANSI Flanged	325
065B8965	3 F 150	6" ANSI Flanged	465

Note:

ESBE 3-way valves are flat faced ANSI flanges, 4-Way valve are DIN raised flanges and require mating DIN weld raised flanges and gaskets. See page 2 for ordering information.

4-Way Valve

Code No.	Reference	Connection	Cv*
065B6150	4 F 50	2" DIN Flanged	75
065B6165	4 F 65	2-1/2" DIN Flanged	105
065B6180	4 F 80	3" DIN Flanged	175
065B6200	4 F 100	4" DIN Flanged	265
065B6225	4 F 125	5" DIN Flanged	325
065B6250	4 F 150	6" DIN Flanged	465

*Cv = Flow rate allowed by the valve in GPM with a pressure drop of one psi.



**Ordering
Information (Cont.):**

DIN Flanges and Gaskets

Code No.	Size	Description
065F8950	2"	DIN Weld Mating Raised Flange (Four Flanges Required per 4-Way Valve)
082F8961	2-1/2"	
082F8962	3"	
082F8963	4"	
082F8964	5"	
082F8965	6"	
065F8951	2"	Gasket for DIN Flange (Four Flanges Required per 4-Way Valve)
082F8966	2-1/2"	
082F8967	3"	
082F8968	4"	
082F8969	5"	
082F8970	6"	

Replacement Parts

Code No.	Description	Valve Sizes	Valve Type
065B0003	Gasket Set	2" – 2-1/2"	3 & 4-Way
065B0004		3" – 6"	
082F8981	Complete Interior	2-1/2"	3-Way
082F8982		3"	
082F8983		4"	
082F8984		5"	
082F8985		6"	
082F8987	Complete Interior	2"	4-Way
082F8988		2-1/2"	
082F8989		3"	
082F8990		4" - 5"	
082F8991		6"	

Technical Specifications:

Max. operating pressure	90 psi (6 bar)
Max. operating temperature	230°F (110°C)
Min. operating temperature	14°F (-10°C)
Max. differential pressure	1-1/2" – 2": 8 psi (50kPa) 2-1/2" – 6": 5 psi (30kPa)
Required motor torque (Recommendation for typical application)	Valve size max. 2" – 45 in lb (5Nm) Valve size max. 4" – 85 in lb (10Nm) Valve size max. 6" – 130 in lb (15Nm) (Recommended exercise function for valve body)
Allowable fluid	Water (maximum 50% glycol) in a closed loop hydronic system.
Connections	3-Way ANSI Flange, flat faced 4-Way DIN Flange, raise faced
Max. Leakage in % of Flow	1.5

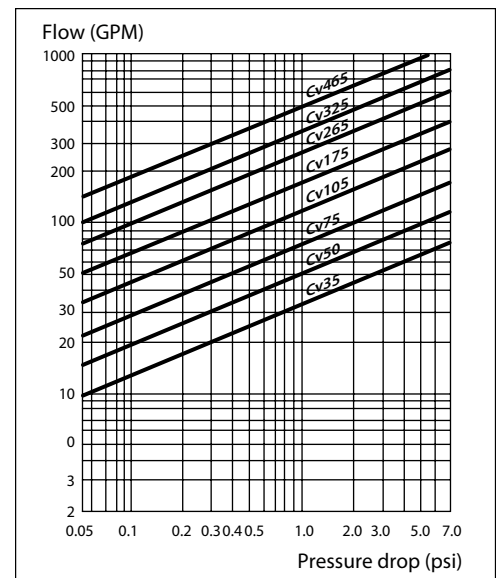
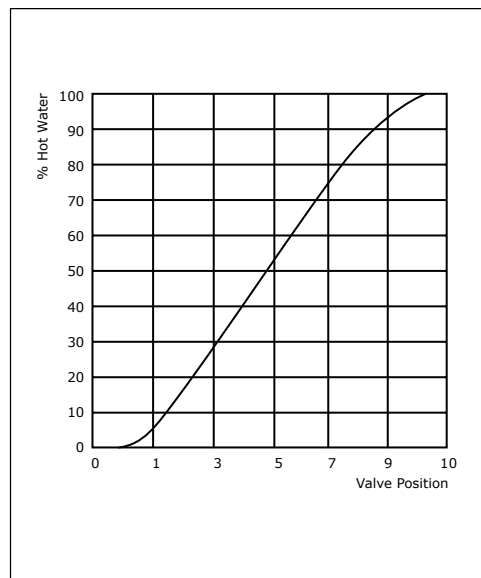

Piping Arrangement:

3-Way Valves

- Ideal valves for mixing and diverting applications
- Reduces risk of low temperature water returning to boiler

4-Way Valves

- Double mixing function, providing proportional mixing from source to system and system to source
- Reduces risk of low temperature water returning to boiler.

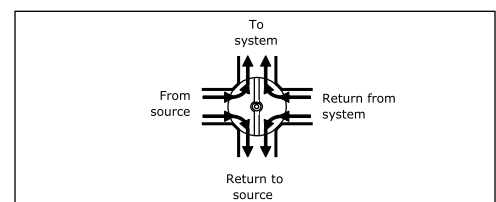
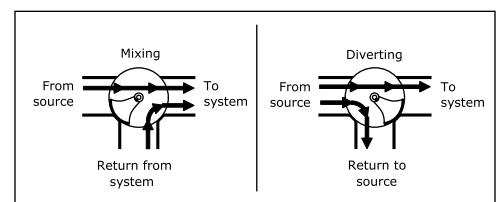

Typical Installation

3-Way Valves

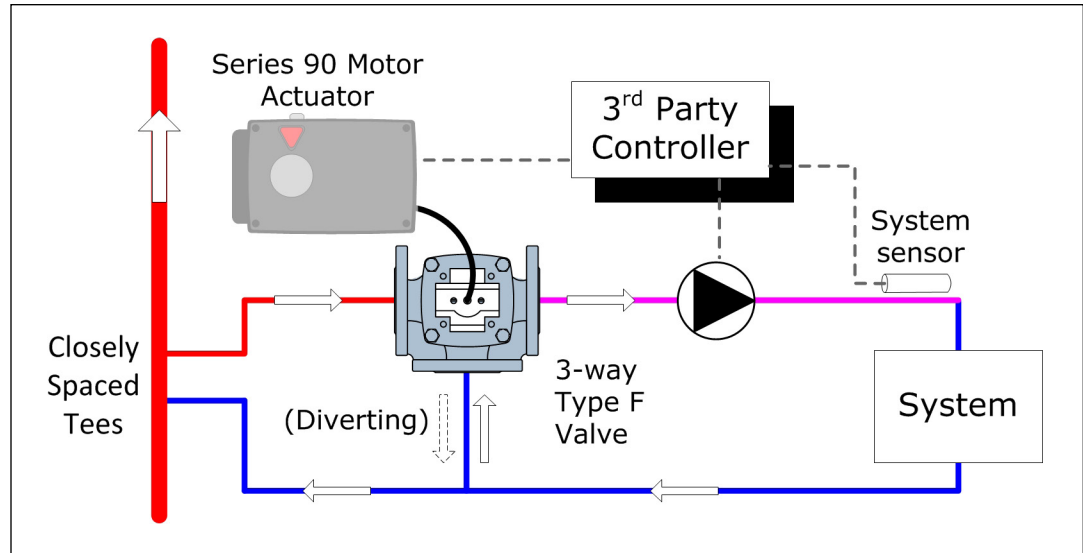

4-Way Valves

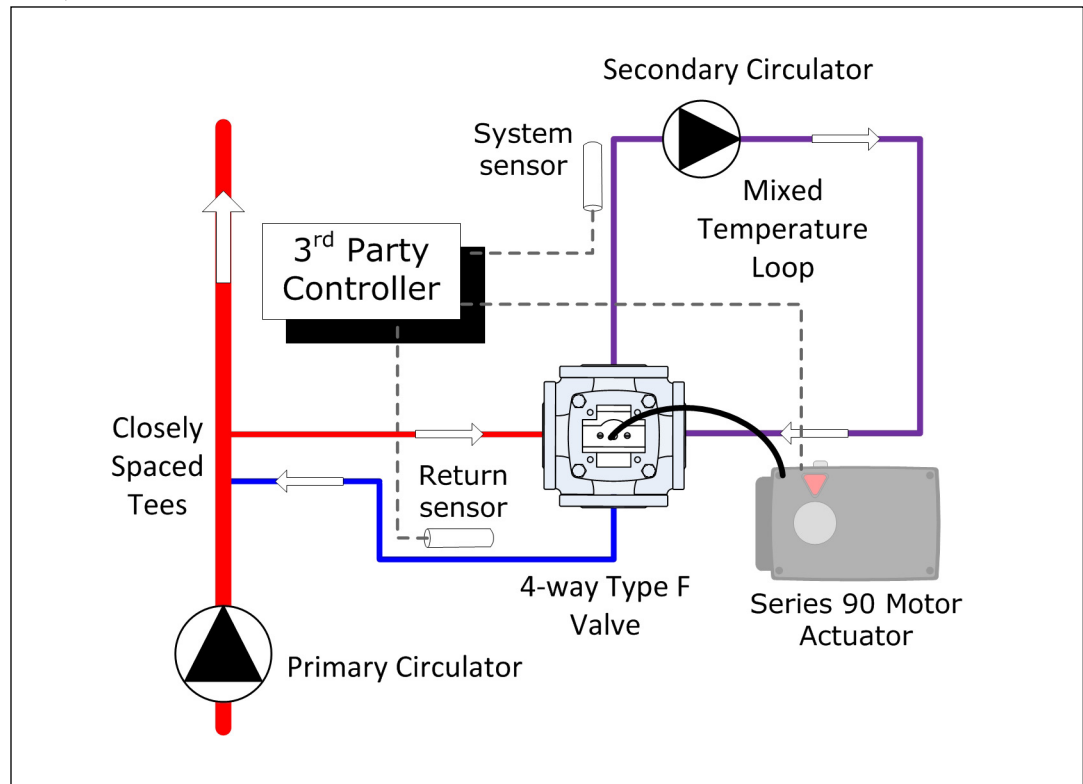

Dimensions:

Material	
Valve Body	Cast iron
Slider	Brass CW 614N & Stainless Steel
Stem	Stainless Steel
O-ring	EPDM
Bushing	Plastic / Brass CW 602N
Cover Plate	Zinc / Cast Iron

Type F 3-Way, in (mm)

Size	Reference	A	B	C	D	E	F	G	Weight lb (kg)
2-½"	3 F65	3.9 (100)	7.9 (200)	2.0 (52)	3.7 (95)	5.5 (139.7)	7.1 (180)	4 x ¾"	30.4 (13.8)
2-½"	3 F65-50	3.9 (100)	7.9 (200)	2.0 (52)	3.7 (95)	5.5 (139.7)	7.1 (180)	4 x ¾"	30.4 (13.8)
3"	3 F80	4.6 (117.5)	9.3 (235)	2.5 (63)	4.2 (106)	6.0 (152.4)	7.5 (190)	4 x ¾"	39.2 (17.8)
4"	3 F100	5.2 (132.5)	10.4 (265)	2.9 (73)	4.6 (116)	7.5 (190.6)	9.1 (230)	8 x ¾"	62.4 (28.3)
5"	3 F125	5.9 (150)	11.8 (300)	3.1 (80)	4.8 (123)	8.5 (215.9)	10.0 (255)	8 x 7/8"	75.2 (34.1)
6"	3 F150	6.9 (175)	13.8 (350)	3.5 (88)	5.1 (130)	9.5 (241.3)	11.0 (280)	8 x 7/8"	97.2 (44.1)

Type F 4-Way, in (mm)

Size	Reference	A	B	C	D	E	F	G	Weight lb (kg)
2"	4 F50	3.9 (98)	7.7 (195)	2.0 (50)	3.6 (92)	4.3 (110)	5.5 (140)	4 x 0.6"	24.3 (11.0)
2-½"	4 F65	3.9 (100)	7.9 (200)	2.0 (50)	3.6 (92)	5.1 (130)	6.3 (160)	4 x 0.6"	26.9 (12.2)
3"	4 F80	4.7 (120)	9.4 (240)	2.6 (65)	4.3 (108)	5.9 (150)	7.5 (190)	4 x 0.7"	44.1 (20.0)
4"	4 F100	5.2 (132)	10.4 (265)	3.2 (81)	4.9 (124)	6.7 (170)	8.3 (210)	4 x 0.7"	55.1 (25.0)
5"	4 F125	5.9 (150)	11.8 (300)	3.2 (81)	4.9 (124)	7.9 (200)	9.4 (240)	8 x 0.7"	77.2 (35.0)
6"	4 F150	6.9 (175)	13.8 (350)	3.5 (89)	5.2 (131)	8.9 (225)	10.4 (265)	8 x 0.7"	99.2 (45.0)



Technical Specifications:

The 3 or 4-Way rotary valve shall be made of a cast iron material with flanged connections. The valve should be capable of being utilized in heating or cooling closed loop applications. The valve position shall have a face plate with printing on both sides to provide a choice of

valve mounting positions. The valve should be capable of assembly with an ESBE series 60 or 90 electric motor actuator.

Danfoss can accept no responsibility for possible errors in printed materials and reserves the right to alter its products without notice. All trademarks in this material are property of the respective companies. Danfoss and Danfoss logotype are trademarks of Danfoss A/S. All rights reserved.



Danfoss

Baltimore, MD / Toronto, ON
Toll Free: 1-888-DANFOSS (326-3677) option #3 for Heating
Fax: 416-352-5981
Email: heating.cs.na@danfoss.com
heating.danfoss.us