



DCC COMMERCIAL

7½- TO 12½-TON THREE-PHASE
PACKAGED AIR CONDITIONERS
UP TO 11.3 EER

Cooling Capacity:
88,000 — 144,000 BTU/h



■ Contents

Nomenclature.....	2
Product Specifications.....	4
Expanded Cooling Data.....	8
Airflow Data.....	16
Heat Kit Electrical Data.....	20
Dimensions.....	24
Wiring Diagrams.....	29
Accessories.....	35

■ Standard Features

- R-410A chlorine-free refrigerant
- High-efficiency scroll compressors
- Two-stage cooling
- Copper tube / aluminum fin coils
- Power block for field wiring
- High- and low-pressure switches
- High-capacity, steel-cased filter drier
- Heater kits with single-point entry
- 24-volt terminal strip
- Units meet the performance outlined in Table 6.8.1A of ASHRAE Standard 90.1-2010
- AHRI Certified; ETL Listed

■ Cabinet Features

- Heavy-gauge, galvanized-steel cabinet with UV-resistant powder-paint finish
- Built-in filter rack with standard 2" filters
- Convertible airflow orientation
- Easy to service
- Full perimeter rail
- Sloped drain pan



* Complete warranty details available from your local dealer or at www.daikincomfort.com.

	D	C	C	090	045	3	B	*	*	*	A	*
	1	2	3	4,5,6	7,8,9	10	11	12	13	14	15	16
	REVISION LEVELS											
	Major & Minor											
	FACTORY-INSTALLED OPTIONS											
BRAND												
D Daikin												
CONFIGURATION												
C Standard Efficiency												
T High Efficiency												
APPLICATION												
C Cooling												
G Gas Heat												
H Heat Pump												
NOMINAL COOLING CAPACITY												
036 3 Tons	102 8½ Tons	300 25 Tons										
048 4 Tons	120 10 Tons											
060 5 Tons	150 12½ tons											
072 6 Tons	180 15 Tons											
090 7½ Tons	240 20 Tons											
NOMINAL HEATING CAPACITY												
Gas/Electric	A/C H/P Factory-Installed Electric Heat											
045 45,000 BTU/h	XXX No Heat											
090 90,000 BTU/h	010 10 kW	030 30 kW										
115 115,000 BTU/h	015 15 kW	031 30 kW										
140 140,000 BTU/h	016 15 kW	045 45 kW										
210 210,000 BTU/h	018 18 kW	046 45 kW										
350 350,000 BTU/h	020 20 kW	060 60 kW										
400 400,000 BTU/h	025 25 kW											
See product specifications for heat size(s) available for each capacity.												
VOLTAGE												
1 208-230/1/60	4 460/3/60											
3 208-230/3/60	7 575/3/60											
SUPPLY FAN/DRIVE TYPE/MOTOR												
B Belt Drive (single speed)	V Two-Speed Belt Drive											
D Direct Drive												
FACTORY-INSTALLED OPTIONS												
X No Options												
A Downflow Economizer												
H Disconnect Switch (non-fused)												
J Downflow Economizer; Disconnect Switch (non-fused)												
Note: Not all options available for all products.												
	FACTORY-INSTALLED OPTIONS											
X	No Options											
A	Non-powered convenience outlet											
B	Powered convenience outlet											
C	Low-ambient kit											
D	Return air smoke detector											
E	Supply air smoke detector											
F	Non-powered convenience outlet; Low-ambient kit											
G	Non-powered convenience outlet; Return air smoke detector											
H	Non-powered convenience outlet; Supply air smoke detector											
J	Non-powered convenience outlet; Return & Supply air smoke detectors											
K	Non-powered convenience outlet; Low-ambient kit; Supply air smoke detector											
L	Non-powered convenience outlet; Low-ambient kit											
M	Return & Supply air smoke detectors											
N	Powered convenience outlet; Low-ambient kit											
O	Powered convenience outlet; Return air smoke detector											
P	Powered convenience outlet; Return & Supply air smoke detectors											
Q	Powered convenience outlet; Supply air smoke detector											
R	Powered convenience outlet; Low-ambient kit; Return air smoke detector											
T	Powered convenience outlet; Low-ambient kit; Return & Supply air smoke detectors											
U	Non-powered convenience outlet; Low-ambient kit; Return air smoke detector											
V	Low-ambient kit; Return air smoke detector											
W	Low-ambient kit; Supply air smoke detector											
Y	Low-ambient kit; Return & Supply air smoke detectors											
Z	Return & Supply air smoke detectors											
X	Standard Aluminized Heat Exchanger											
S	Stainless-Steel Heat Exchanger											

FACTORY-INSTALLED OPTIONS

- Stainless-Steel Heat Exchanger (DCG units only): A tubular heat exchanger made of 409-type stainless steel is installed in the unit.
- Low-Ambient Kit: Allows for cooling operation at lower outdoor temperatures. On the 3- to 6-ton units, cooling operation is extended from 60°F ambient temperature to 35°F outside air temperature. On 7½- to 20-ton units, cooling operation is extended from 35°F ambient temperature to 0°F outside air temperature.
- Economizers (Downflow): Based on air conditions, can provide outside air to cool the space.
- Electric Heat Kits (DCC and DCH units only): Available in all voltage options.
- Non-powered Convenience Outlet: A 120V, 15A, GFCI outlet makes it easier for technicians to service the unit once an electrician runs power to the outlet.
- Powered Convenience Outlet: A 120V, 15A, GFCI outlet powered with a transformer built into the unit. When a factory-installed powered convenience outlet is installed in the equipment, the unit MCA (Min. Circuit Ampacity) will increase by 7.5A for 208/230V units, increase by 3.75A for 460V units, and by 3A for 575V units. The MOP (Max. Overcurrent Protection) device must be sized accordingly.
- Disconnect Switch (non-fused): A disconnect switch is installed in the unit and factory wiring will be complete from the switch to the unit. Please note that for air conditioning (DCC units) and heat pump models (DCH units), the appropriate electric heat kit must be ordered to be factory-installed along with the disconnect switch (non-fused) when it is ordered. Please note that for models with a powered convenience outlet option and a disconnect switch (non-fused) option, the power to the powered convenience outlet will be shut off when the disconnect switch (non-fused) is in the off position.
- Return Air and/or Supply Air Smoke Detectors: Return air and/or supply air smoke detectors are installed in the unit.
- Two-speed indoor fan blower models are available on 7½, 8½, 10, 12½, 15, & 20-ton units. Section 6.4.3.10.b of ASHRAE Standard 90.1-2010 and Section 6.5.3.2.1.a of ASHRAE Standard 90.1-2013 require a minimum of two fan speeds. Section 140.4(m)1 of California Energy Commission Title 24 2013 contains a similar provision. When the units with the two-speed indoor fan blowers operate on a call for the first stage of cooling, the fan operates at low speed, which is 66% of full speed. When the units operate on a call for the second stage of cooling, the fan operates at full speed. In heating operation, the fan operates at full speed. During ventilation operation, the fan operates at low speed.

	DCC090 ***3B***A*	DCC090 ***3V***A*	DCC090 ***4B***A*	DCC090 ***4V***A*	DCC090 ***7B***A*	DCC090 ***7V***A*
COOLING CAPACITY						
Total BTU/h	88,000	88,000	88,000	88,000	88,000	88,000
Sensible BTU/h	65,100	65,100	65,100	65,100	65,100	65,100
EER / IEER	11.3 / 11.5	11.3 / 13.0	11.3 / 11.5	11.3 / 13.0	11.3 / 11.5	11.3 / 13.0
Decibels	82	82	82	82	82	82
AHRI Reference #s	7041907	7041910	7041907	7041910	7041907	7041910
EVAPORATOR MOTOR / COIL						
Motor Type	Belt Drive	2-Speed Belt	Belt Drive	2-Speed Belt	Belt Drive	2-Speed Belt
Indoor Nominal CFM	3,000	3,000	3,000	3,000	3,000	3,000
Indoor Motor FLA (Cooling)	5.0	6.0	2.5	2.9	2.3	2.4
Horsepower / RPM	1.5 / 1745	2 / 1740-1160	1.5 / 1745	2 / 1740-1160	1.5 / 1725	2 / 1745-1170
Piston Size (Cooling)	0.078	0.078	0.078	0.078	0.078	0.078
Filter Size (Qty)	16 x 20 x 2	16 x 20 x 2	16 x 20 x 2	16 x 20 x 2	16 x 20 x 2	16 x 20 x 2
Drain Size (NPT)	¾"	¾"	¾"	¾"	¾"	¾"
R-410A Refrigerant Charge Cir #1 & #2	100 oz.	100 oz.	100 oz.	100 oz.	100 oz.	100 oz.
Evaporator Coil Face Area (ft²)	8.9	8.9	8.9	8.9	8.9	8.9
Rows Deep / Fins per Inch	4 / 16	4 / 16	4 / 16	4 / 16	4 / 16	4 / 16
BELT DRIVE EVAP FAN DATA						
# of Wheels (D x W)	1 (15" x 12")	1 (15" x 12")	1 (15" x 12")	1 (15" x 12")	1 (15" x 12")	1 (15" x 12")
Motor Sheave / Blower Sheave	VL40 / AK74	VL40 / AK74	VL40 / AK74	VL40 / AK74	VL40 / AK74	VL40 / AK74
Belt	AX51	AX51	AX51	AX51	AX51	AX51
CONDENSER FAN / COIL						
Quantity of Condenser Fan Motors	2	2	2	2	2	2
Horsepower - RPM	¼ - 1075	¼ - 1075	¼ - 1075	¼ - 1075	¼ - 1,075	¼ - 1,075
Fan Diameter / # Fan Blades	22 / 4	22 / 4	22 / 4	22 / 4	22 / 4	22 / 4
Outdoor Nominal CFM	7,200	7,200	7,200	7,200	7,200	7,200
Face Area (ft²)	28.8	28.8	28.8	28.8	28.8	28.8
Rows Deep / Fins per Inch	2 X2 / 27±1	2 X2 / 27±1	'2 X2 / 27±1	'2 X2 / 27±1	'2 X2 / 27±1	'2 X2 / 27±1
COMPRESSOR						
Quantity / Type / Stage	2 / Scroll / 1	2 / Scroll / 1	2 / Scroll / 1	2 / Scroll / 1	2 / Scroll / 1	2 / Scroll / 1
Compressor RLA / LRA	13.1 / 83.1	13.1 / 83.1	6.1 / 41.0	6.1 / 41.0	4.4 / 33.0	4.4 / 33.0
ELECTRICAL DATA						
Voltage-Phase-Frequency	208/230-3-60	208/230-3-60	460-3-60	460-3-60	575-3-60	575-3-60
Max External Static	1.0"	1.0"	1.0"	1.0"	1.0"	1.0"
Outdoor Fan HP / RLA	(2) ¼ / 1.4	(2) ¼ / 1.4	(2) ¼ / 0.7	(2) ¼ / 0.7	(2) ¼ / 0.55	(2) ¼ / 0.55
Total Unit Amps	34.0	35.0	16.1	16.5	12.2	12.3
Min. Circuit Ampacity ¹	37.3	38.3	17.8	18.0	13.3	13.4
Max. Overcurrent Protection (amps) ²	50	50	20	20	15	15
Entrance Power Supply	Locating	Locating	Locating	Locating	Locating	Locating
Entrance Control Voltage	Dimple	Dimple	Dimple	Dimple	Dimple	Dimple
OPERATING WEIGHT (LBS)	1010	1010	1010	1010	1010	1010
SHIP WEIGHT (LBS)	1085	1085	1085	1085	1085	1085

¹ Wire size should be determined in accordance with National Electrical Codes. Extensive wire runs will require larger wire sizes.

² May use fuses or HACR-type circuit breakers of the same size as noted.

Note: Always check the S&R plate for electrical data on the unit being installed.

	DCC102 ***3B***A*	DCC102 ***3V***A*	DCC102 ***4B***A*	DCC102 ***4V***A*	DCC102 ***7B***A*	DCC102 ***7V***A*
COOLING CAPACITY						
Total BTU/h	102,000	102,000	102,000	102,000	102,000	102,000
Sensible BTU/h	70,380	70,380	70,380	70,380	70,380	70,380
EER / IEER	11.3 / 11.4	11.3/13.4	11.3 / 11.4	11.3/13.4	11.3 / 11.4	11.3/13.4
Decibels	83	83	83	83	83	83
ARI Reference #s	7370920	7370923	7370920	7370923	7370920	7370923
EVAPORATOR MOTOR / COIL						
Motor Type	Belt Drive	Belt Drive	Belt Drive	Belt Drive	Belt Drive	Belt Drive
Indoor Nominal CFM	3,200	3,200	3,200	3,200	3,200	3,200
Indoor motor FLA (Cooling)	7.8	6.0	3.9	2.9	2.3	2.4
Horsepower - RPM	2 / 1725	2 / 1740-1160	2 / 1725	2 / 1740-1160	2 / 1725	2 / 1745-1170
Piston Size (Cooling)	0.080	0.080	0.080	0.080	0.080	0.080
Filter Size (Qty)	(4) 16 x 20 x 2	(4) 16 x 20 x 2	(4) 16 x 20 x 2	(4) 16 x 20 x 2	(4) 16 x 20 x 2	(4) 16 x 20 x 2
Drain Size (NPT)	3/4"	3/4"	3/4"	3/4"	3/4"	3/4"
R-410A Refrigerant Charge Cir #1 & #2	110 oz.	110 oz	110 oz.	110 oz	110 oz.	110 oz
Evaporator Coil Face Area (ft ²)	10.2	10.2	10.2	10.2	10.2	10.2
Rows Deep / Fins per Inch	4 / 14	4 / 14	4 / 14	4 / 14	4 / 14	4 / 14
BELT DRIVE EVAP FAN DATA						
# of Wheels (D x W)	(1) 15" x 12"	(1) 15" x 12"	(1) 15" x 12"	(1) 15" x 12"	(1) 15" x 12"	(1) 15" x 12"
Motor Sheave / Blower Sheave	VL40 / AK74	VL40 / AK74	VL40 / AK74	VL40 / AK74	VL40 / AK74	VL40 / AK74
Belt	AX51	AX51	AX51	AX51	AX51	AX51
CONDENSER FAN / COIL						
Quantity of Condenser Fan Motors	2	2	2	2	2	2
Horsepower - RPM	½ - 1,075	½ - 1,075	½ - 1,075	½ - 1,075	½ - 1,075	½ - 1,075
Fan Diameter / # Fan Blades	22 / 3	22 / 3	22 / 3	22 / 3	22 / 3	22 / 3
Outdoor Nominal CFM	8,200	8,200	8,200	8,200	8,200	8,200
Face Area (ft ²)	28.8	28.8	28.8	28.8	28.8	28.8
Rows Deep - Fins per Inch	2 X2 / 27±1	2 X2 / 27±1	2 X2 / 27±1	2 X2 / 27±1	2 X2 / 27±1	2 X2 / 27±1
COMPRESSOR						
Quantity / Type / Stage	2 / Scroll / 1	2 / Scroll / 1	2 / Scroll / 1	2 / Scroll / 1	2 / Scroll / 1	2 / Scroll / 1
Compressor RLA / LRA ea.	14.5 / 98	14.5 / 98	6.3 / 55	6.3 / 55	6.0 / 41	6.0 / 41
ELECTRICAL DATA						
Voltage/Phase/ Frequency	230 / 3 / 60	230 / 3 / 60	460 / 3 / 60	460 / 3 / 60	575 / 3 / 60	575 / 3 / 60
Standard Max Static	1"	1"	1	1	1	1
Outdoor Fan RLA ea.	1.40	1.40	0.70	0.70	0.55	0.55
Total Unit Amps	39.6	37.8	18.9	16.9	16.1	16.2
Min. Circuit Ampacity ¹	43.2	41.4	20.5	18.5	17.8	17.9
Max. Overcurrent Protection (amps) ²	50	50	25	20	20	20
Entrance Power Supply	Locating Dimple	Locating Dimple	Locating Dimple	Locating Dimple	Locating Dimple	Locating Dimple
Entrance Control Voltage						
OPERATING WEIGHT (LBS)	1050	1050	1050	1050	1050	1050
SHIP WEIGHT (LBS)	1125	1125	1125	1125	1125	1125

¹ Wire size should be determined in accordance with National Electrical Codes. Extensive wire runs will require larger wire sizes.

² May use fuses or HACR-type circuit breakers of the same size as noted.

Note: Always check the S&R plate for electrical data on the unit being installed.

	DCC120 ***3B***A*	DCC120 ***3V***A*	DCC120 ***4B***A*	DCC120 ***4V***A*	DCC120 ***7B***A*	DCC120 ***7V***A*
COOLING CAPACITY						
Total BTU/h	116,000	116,000	116,000	116,000	116,000	116,000
Sensible BTU/h	84,700	84,700	84,700	84,700	84,700	84,700
EER / IEER	11.3 / 11.5	11.3 / 13.0	11.3 / 11.5	11.3 / 13.0	11.3 / 11.5	11.3 / 13.0
Decibels	83	83	83	83	83	83
ARI Reference #s	6345711	6345712	6345711	6345712	6345711	6345712
EVAPORATOR MOTOR / COIL						
Motor Type	Belt Drive	Belt Drive	Belt Drive	Belt Drive	Belt Drive	Belt Drive
Indoor Nominal CFM	3,500	3,500	3,500	3,500	3,500	3,500
Indoor motor FLA (Cooling)	7.8	6.4	3.9	3.3	2.5	2.4
Horsepower - RPM	2.0/1725	2.0/1750-1165	2.0/1725	2.0/1750-1165	2.0/1725	2.0/1750-1165
Piston Size (Cooling)	0.086	0.086	0.086	0.086	0.084	0.086
Filter Size (Qty)	(4) 16 x 24 x 2	(4) 16 x 24 x 2	(4) 16 x 24 x 2	(4) 16 x 24 x 2	(4) 16 x 24 x 2	(4) 16 x 24 x 2
Drain Size (NPT)	¾"	¾"	¾"	¾"	¾"	¾"
R-410A Refrigerant Charge Cir #1 & #2 (oz.)	144 / 123	144 / 123	144 / 123	144 / 123	144 / 123	144 / 123
Evaporator Coil Face Area (ft ²)	10.2	10.2	10.2	10.2	10.2	10.2
Rows Deep / Fins per Inch	4 / 14	4 / 14	4 / 14	4 / 14	4 / 14	4 / 14
BELT DRIVE EVAP FAN DATA						
# of Wheels (D x W)	(1) 15" x 15"	(1) 15" x 15"	(1) 15" x 15"	(1) 15" x 15"	(1) 15" x 15"	(1) 15" x 15"
Motor Sheave / Blower Sheave	VL40 / AK74	VL40 / AK74	VL40 / AK74	VL40 / AK74	VL40 / AK74	VL40 / AK74
Belt	AX51	AX50	AX51	AX50	AX51	AX50
CONDENSER FAN / COIL						
Quantity of Condenser Fan Motors	2	2	2	2	2	2
Horsepower - RPM	⅓ - 1,075	⅓ - 1,075	⅓ - 1,075	⅓ - 1,075	⅓ - 1,125	⅓ - 1,125
Fan Diameter / # Fan Blades	22 / 3	22 / 3	22 / 3	22 / 3	22 / 3	22 / 3
Outdoor Nominal CFM	8,200	8,200	8,200	8,200	8,200	8,200
Face Area (ft ²)	35.2	35.2	35.2	35.2	35.2	35.2
Rows Deep - Fins per Inch	2 X2 / 27±1	2 X2 / 27±1	'2 X2 / 27±1	'2 X2 / 27±1	'2 X2 / 27±1	'2 X2 / 27±1
COMPRESSOR						
Quantity / Type / Stage	2 / Scroll / 1	2 / Scroll / 1	2 / Scroll / 1	2 / Scroll / 1	2 / Scroll / 1	2 / Scroll / 1
Compressor RLA / LRA ea.	16/110.0	16/110.0	7.8/52.0	7.8/52.0	5.7/38.9	5.7/38.9
ELECTRICAL DATA						
Voltage/Phase/ Frequency	208/230-3-60	208/230-3-60	460-3-60	460-3-60	575-3-60	575-3-60
Standard Max Static	1.4"	1.4"	1.4"	1.4"	1.4"	1.4"
Outdoor Fan RLA ea.	2.00	2.00	0.85	0.85	0.67	0.67
Total Unit Amps	45	43	22	21	16	16
Min. Circuit Ampacity ¹	49	47	24	23	17	17
Max. Overcurrent Protection (amps) ²	60	60	30	30	20	20
Entrance Power Supply	Locating Dimple	Locating Dimple	Locating Dimple	Locating Dimple	Locating Dimple	Locating Dimple
Entrance Control Voltage						
OPERATING WEIGHT (LBS)	1050	1050	1050	1050	1050	1050
SHIP WEIGHT (LBS)	1125	1125	1125	1125	1125	1125

¹ Wire size should be determined in accordance with National Electrical Codes. Extensive wire runs will require larger wire sizes.

² May use fuses or HACR-type circuit breakers of the same size as noted.

Note: Always check the S&R plate for electrical data on the unit being installed.

	DCC150 ***3B***A*	DCC150 ***3V***A*	DCC150 ***4B***A*	DCC150 ***4V***A*	DCC150 ***7B***A*	DCC150 ***7V***A*
COOLING CAPACITY						
Total, BTU/h	144,000	144,000	144,000	144,000	144,000	144,000
Sensible BTU/h	100,000	100,000	100,000	100,000	100,000	100,000
EER / IEER	11.0 / 11.2	11.0 / 12.2	11.0 / 11.2	11.0 / 12.2	11.0 / 11.2	11.0 / 12.2
Decibels	83	83	83	83	83	83
ARI Reference #s	6885861	6885864	6885861	6885864	6885861	6885864
EVAPORATOR MOTOR / COIL						
Motor Type	Belt Drive	Belt Drive	Belt Drive	Belt Drive	Belt Drive	Belt Drive
Indoor Nominal CFM	3,900	3,900	3,900	3,900	3,900	3,900
Indoor Motor FLA (Cooling)	9.4	9.1	4.7	4.3	4.2	3.5
Horsepower - RPM	3.0 - 1,725	3.0/1760-1165	3.0 - 1,725	3.0/1760-1165	3.0 - 1,725	3.0/1760-1165
Piston Size (Cooling)	0.092	0.092	0.092	0.092	0.092	0.092
Filter Size	(4) 20" x 25" x 2"	(4) 20" x 25" x 2"	(4) 20" x 25" x 2"	(4) 20" x 25" x 2"	(4) 20" x 25" x 2"	(4) 20" x 25" x 2"
Drain Size (NPT)	¾"	¾"	¾"	¾"	¾"	¾"
R-410A Refrigerant Charge Cir #1 & #2	175 oz	175 oz	175 oz	175 oz	175 oz	175 oz
Evaporator Coil Face Area (ft ²)	14.7	14.7	14.7	14.7	14.7	14.7
Rows Deep / Fins per Inch	4 / 15	4 / 15	4 / 15	4 / 15	4 / 15	4 / 15
CONDENSER FAN / COIL						
Quantity of condenser Fan Motors	2	2	2	2	2	2
Horsepower - RPM	½ - 1,075	½ - 1,075	½ - 1,075	½ - 1,075	½ - 1,075	½ - 1,075
Fan Diameter / # Fan Blades	22/3	22/3	22/3	22/3	22/3	22/3
Outdoor Nominal CFM	8,400	8,400	8,400	8,400	8,400	8,400
Face Area (ft ²)	39.0	39.0	39.0	39.0	39.0	39.0
Rows Deep - Fins per Inch	2/2 - 27	2/2 - 27	2/2 - 27	2/2 - 27	2/2 - 27	2/2 - 27
BELT DRIVE EVAP FAN DATA						
# of Wheels (D x W)	(1) 15" x 15"	(1) 15" x 15"	(1) 15" x 15"	(1) 15" x 15"	(1) 15" x 15"	(1) 15" x 15"
Motor Sheave / Blower Sheave	VL40 / AK66	VP44 / AK71	VL40 / AK66	VP44 / AK71	VL40 / AK66	VP44 / AK71
Belt	AX49	AX48	AX49	AX48	AX49	AX48
COMPRESSOR						
Quantity / Type / Stage	2 / Scroll / 1	2 / Scroll / 1	2 / Scroll / 1	2 / Scroll / 1	2 / Scroll / 1	2 / Scroll / 1
Compressor RLA / LRA ea.	22.4 / 149	22.4 / 149	10.6 / 75	10.6 / 75	7.7 / 54	7.7 / 54
ELECTRICAL DATA / STATIC						
Voltage / Phase / Frequency	208-230/3/60	208-230/3/60	460/3/60	460/3/60	575/3/60	575/3/60
Standard Max Static	1.4"	1.4"	1.4"	1.4"	1.4"	1.4"
Outdoor Fan FLA ea.	2.00	2.00	0.85	0.85	0.67	0.67
Total Unit Amps	59	57.9	28	26.9	21.4	20.7
Min. Circuit Ampacity ¹	65	63.5	31	29.9	23	23
Max. Overcurrent Protection (amps) ²	80	80	40	40	30	30
Entrance Power Supply	Locating Dimple	Locating Dimple	Locating Dimple	Locating Dimple	Locating Dimple	Locating Dimple
Entrance Control Voltage						
OPERATING WEIGHT (LBS)	1225	1225	1225	1225	1225	1225
SHIP WEIGHT (LBS)	1250	1250	1250	1250	1250	1250

¹ Wire size should be determined in accordance with National Electrical Codes. Extensive wire runs will require larger wire sizes.

² May use fuses or HACR-type circuit breakers of the same size as noted.

Note: Always check the S&R plate for electrical data on the unit being installed.

IDB		OUTDOOR AMBIENT TEMPERATURE																											
		65				75				85				95				105				115							
		59	63	67	71	59	63	67	71	59	63	67	71	59	63	67	71	59	63	67	71	59	63	67	71				
		ENTERING INDOOR WET BULB TEMPERATURE																											
AIRFLOW		59	63	67	71	59	63	67	71	59	63	67	71	59	63	67	71	59	63	67	71	59	63	67	71	59	63	67	71
3375	MBh	86.2	89.4	97.9	-	84.2	87.3	95.6	-	82.2	85.2	93.4	-	80.2	83.1	91.1	-	76.2	79.0	86.5	-	70.6	73.2	80.2	-				
	S/T	0.74	0.62	0.43	-	0.77	0.64	0.45	-	0.79	0.66	0.46	-	0.82	0.68	0.47	-	0.85	0.71	0.49	-	0.85	0.71	0.49	-				
	ΔT	17	15	11	-	18	15	12	-	18	15	12	-	18	15	12	-	18	15	12	-	16	14	11	-				
	kW	6.12	6.24	6.42	-	6.56	6.69	6.89	-	6.94	7.08	7.30	-	7.28	7.43	7.66	-	7.57	7.73	7.97	-	7.82	7.99	8.24	-				
	Hi PR	234	252	266	-	262	282	298	-	298	321	339	-	340	366	386	-	382	411	434	-	422	454	480	-				
Lo PR	108	115	126	-	114	122	133	-	119	126	138	-	125	133	145	-	131	139	152	-	135	144	157	-					
70	MBh	83.7	86.8	95.1	-	81.8	84.8	92.9	-	79.8	82.7	90.7	-	77.9	80.7	88.4	-	74.0	76.7	84.0	-	68.5	71.0	77.8	-				
	S/T	0.71	0.59	0.41	-	0.73	0.61	0.43	-	0.75	0.63	0.44	-	0.78	0.65	0.45	-	0.81	0.67	0.47	-	0.81	0.68	0.47	-				
	ΔT	18	16	12	-	18	16	12	-	18	16	12	-	19	16	12	-	18	16	12	-	17	15	11	-				
	kW	6.07	6.19	6.37	-	6.51	6.64	6.84	-	6.89	7.03	7.24	-	7.23	7.38	7.60	-	7.51	7.67	7.91	-	7.76	7.92	8.17	-				
	Hi PR	231	249	263	-	260	279	295	-	295	317.8	335.6	-	336	361.9	382.2	-	378	407.2	430.0	-	418	449.9	475.1	-				
Lo PR	107	114	124	-	113	120	132	-	118	125	137	-	124	132	144	-	130	138	150	-	134	143	156	-					
2400	MBh	77	80	88	-	75	78	86	-	74	76	84	-	72	75	82	-	68	71	78	-	63	66	72	-				
	S/T	0.68	0.57	0.40	-	0.71	0.59	0.41	-	0.73	0.61	0.42	-	0.75	0.63	0.43	-	0.78	0.65	0.45	-	0.78	0.66	0.45	-				
	ΔT	20	18	13	-	20	18	13	-	21	18	13	-	21	18	14	-	20	18	13	-	19	16	12	-				
	kW	5.94	6.06	6.23	-	6.36	6.49	6.68	-	6.73	6.87	7.08	-	7.06	7.20	7.42	-	7.34	7.49	7.72	-	7.58	7.73	7.98	-				
	Hi PR	224	242	255	-	252	271	286	-	286	308.3	325.5	-	326	351.1	370.7	-	367	395.0	417.1	-	406	436.4	460.8	-				
Lo PR	104	111	121	-	110	117	128	-	114	121	133	-	120	128	139	-	126	134	146	-	130	138	151	-					
3375	MBh	88	90	98	105	86	88	95	102	84	86	93	100	82	84	91	98	80	82	89	96	77	79	86	93				
	S/T	0.84	0.76	0.57	0.37	0.88	0.78	0.59	0.38	0.90	0.80	0.61	0.39	0.93	0.83	0.63	0.40	0.96	0.86	0.65	0.42	0.96	0.86	0.65	0.42				
	ΔT	20	19	15	11	20	19	15	11	20	19	15	11	21	19	16	11	20	19	15	11	20	19	15	11				
	kW	6.17	6.29	6.47	6.7	6.61	6.74	6.94	7.2	7.00	7.14	7.36	7.6	7.34	7.49	7.73	8.0	7.63	7.79	8.04	8.3	7.88	8.05	8.31	8.6				
	Hi PR	236	254	268	280	265	285	301	314	301.3	324	342	357	343.2	369	390	407	386	415	439	458	427	459	485	506				
Lo PR	109	116	127	135	116	123	134	143	120	128	139	149	126	134	146	156	132	141	154	163	137	145	159	169					
75	MBh	85	88	95	102	83	86	93	99	81	84	90	97	79	82	88	95	77	79	84	90	75	77	84	90				
	S/T	0.81	0.72	0.55	0.35	0.84	0.75	0.57	0.36	0.86	0.77	0.58	0.37	0.88	0.79	0.60	0.38	0.92	0.82	0.62	0.40	0.93	0.83	0.63	0.40				
	ΔT	21	19	16	11	21	20	16	11	21	20	16	11	21	20	16	11	21	19	16	11	20	18	15	10				
	kW	6.12	6.24	6.42	6.6	6.56	6.69	6.89	7.1	6.94	7.09	7.30	7.5	7.28	7.43	7.66	7.9	7.57	7.73	7.97	8.2	7.82	7.99	8.24	8.5				
	Hi PR	234	252	266	277	262	282	298	311	298.3	321	339	354	339.8	366	386	403	382	411	434	453	422	454	480	501				
Lo PR	108	115	126	134	114	122	133	141	119	126	138	147	125	133	145	154	131	139	152	162	135	144	157	167					
2400	MBh	79	81	88	94	77	79	86	92	75	77	84	90	73	75	81	87	69	72	77	83	64	66	72	76.9				
	S/T	0.78	0.69	0.53	0.34	0.81	0.72	0.55	0.35	0.83	0.74	0.56	0.36	0.85	0.76	0.58	0.37	0.88	0.79	0.60	0.39	0.89	0.80	0.60	0.39				
	ΔT	23	22	18	12	24	22	18	12	24	22	18	12	24	22	18	12	24	22	18	12	22	20	17	11				
	kW	5.99	6.10	6.28	6.5	6.41	6.54	6.73	6.9	6.78	6.92	7.13	7.4	7.11	7.26	7.48	7.7	7.39	7.55	7.78	8.0	7.64	7.80	8.04	8.3				
	Hi PR	227	244	258	269	254	274	289	302	289.4	311	329	343	329.6	355	375	391	371	399	421	439	410	441	466	486				
Lo PR	105	112	122	130	111	118	129	137	115	123	134	143	121	129	141	150	127	135	147	157	131	140	153	162					

IDB: Entering Indoor Dry Bulb Temperature
 High and low pressures are measured at the liquid and suction access fittings.
 Shaded area reflects ACCA (TVA) Rating Conditions
 Design Superheat 7±2 °F; Design Subcooling 12 ±2 °F; pressures measured @ the suction and liquid service ports, AHRI 95 test conditions
 Amps: Unit amps (comp.+ evaporator + condenser fan motors)

IDB		OUTDOOR AMBIENT TEMPERATURE																							
		75				85				95				105				115							
		59	63	67	71	59	63	67	71	59	63	67	71	59	63	67	71	59	63	67	71				
		ENTERING INDOOR WET BULB TEMPERATURE																							
		AIRFLOW																							
80	MBh	89.3	91.2	97.4	104.2	87.2	89.1	95.2	101.7	85.1	87.0	92.9	99.3	83.0	84.8	90.6	96.9	78.9	80.6	86.1	92.0	73.1	74.7	79.8	85.3
	S/T	0.93	0.87	0.71	0.53	0.96	0.90	0.73	0.55	1.00	0.92	0.75	0.56	1.00	0.95	0.78	0.58	1.00	1.00	0.81	0.60	1.00	1.00	0.81	0.61
	ΔT	23	22	19	15	23	22	19	15	23	22	19	15	23	22	19	15	21	22	19	15	20	20	18	14
	kW	6.21	6.33	6.52	6.7	6.66	6.79	7.00	7.2	7.05	7.20	7.42	7.6	7.40	7.55	7.79	8.0	7.69	7.86	8.10	8.4	7.95	8.12	8.37	8.6
	Hi PR	238	257	271	283	268	288	304	317	304	328	346	361	347	373	394	411	390	420	443	462	431	464	490	511
Lo PR	110	118	128	137	117	124	136	144	121	129	141	150	127	136	148	158	134	142	155	165	138	147	160	171	
3000	MBh	86.7	88.5	94.6	101.1	84.6	86.5	92.4	98.8	82.6	84.4	90.2	96.4	80.6	82.4	88.0	94.1	76.6	78.2	83.6	89.4	70.9	72.5	77.4	82.8
	S/T	0.88	0.83	0.67	0.50	0.92	0.86	0.70	0.52	0.94	0.88	0.72	0.54	0.97	0.91	0.74	0.55	1.00	0.94	0.77	0.57	1.00	0.95	0.77	0.58
	ΔT	23	22	20	16	24	23	20	16	24	23	20	16	24	23	20	16	23	23	20	16	22	21	18	15
	kW	6.17	6.29	6.47	6.7	6.61	6.74	6.94	7.2	7.00	7.14	7.36	7.6	7.34	7.49	7.73	8.0	7.63	7.79	8.04	8.3	7.89	8.05	8.31	8.6
	Hi PR	236	254	268	280	265	285	301	314	301	324	342	357	343	369	390	407	386	415	439	458	427	459	485	506
Lo PR	109	116	127	135	116	123	134	143	120	128	139	149	126	134	147	156	132	141	154	164	137	145	159	169	
2400	MBh	80.0	81.7	87.3	93.3	78.1	79.8	85.3	91.2	76.3	77.9	83.3	89.0	74.4	76.0	81.2	86.8	70.7	72.2	77.2	82.5	65.5	66.9	71.5	76.4
	S/T	0.85	0.80	0.65	0.49	0.88	0.83	0.67	0.50	0.91	0.85	0.69	0.52	0.93	0.88	0.71	0.53	0.97	0.91	0.74	0.55	0.98	0.92	0.75	0.56
	ΔT	26	25	22	17	26	25	22	18	26	25	22	18	27	26	22	18	26	25	22	17	25	24	20	16
	kW	6.03	6.15	6.33	6.5	6.46	6.59	6.78	7.0	6.84	6.97	7.19	7.4	7.17	7.32	7.54	7.8	7.45	7.61	7.85	8.1	7.70	7.86	8.11	8.4
	Hi PR	229	246	260	271	257	277	292	305	292	315	332	346	333	358	378	395	375	403	426	444	414	445	470	490
Lo PR	106	113	123	131	112	119	130	139	116	124	135	144	122	130	142	151	128	136	149	159	133	141	154	164	
85	MBh	90.8	92.6	97.0	103.4	88.7	90.4	94.7	101.0	86.6	88.3	92.4	98.6	84.5	86.1	90.2	96.2	80.3	81.8	85.7	91.4	74.3	75.8	79.4	84.7
	S/T	0.97	0.94	0.85	0.69	1.00	0.97	0.88	0.71	1.00	1.00	0.90	0.73	1.00	1.00	0.93	0.75	1.00	1.00	0.96	0.78	1.00	1.00	0.97	0.79
	ΔT	24	24	22	19	24	24	23	20	24	24	23	20	23	23	23	20	22	22	22	19	20	21	21	18
	kW	6.26	6.38	6.57	6.8	6.71	6.84	7.05	7.3	7.11	7.25	7.47	7.7	7.46	7.61	7.85	8.1	7.75	7.92	8.17	8.4	8.01	8.18	8.44	8.7
	Hi PR	241	259	274	285	270	291	307	320	307	331	349	364	350	377	398	415	394	424	448	467	435	468	495	516
Lo PR	112	119	130	138	118	125	137	146	122	130	142	152	129	137	149	159	135	143	157	167	139	148	162	173	
3000	MBh	88.2	89.9	94.1	100.4	86.1	87.8	91.9	98.1	84.1	85.7	89.7	95.7	82.0	83.6	87.6	93.4	77.9	79.4	83.2	88.7	72.2	73.6	77.1	82.2
	S/T	0.93	0.89	0.81	0.65	0.96	0.93	0.84	0.68	0.98	0.95	0.86	0.70	1.00	0.98	0.89	0.72	1.00	1.00	0.92	0.75	1.00	1.00	0.93	0.75
	ΔT	25	25	23	20	25	25	24	20	25	25	24	20	25	25	24	21	24	24	23	20	22	23	22	19
	kW	6.21	6.33	6.52	6.7	6.66	6.79	7.00	7.2	7.05	7.20	7.42	7.6	7.40	7.55	7.79	8.0	7.69	7.86	8.10	8.4	7.95	8.12	8.37	8.6
	Hi PR	238	257	271	283	268	288	304	317	304	328	346	361	347	373	394	411	390	420	443	462	431	464	490	511
Lo PR	110	118	128	137	117	124	136	144	121	129	141	150	127	136	148	158	134	142	155	165	138	147	160	171	
2400	MBh	81.4	83.0	86.9	92.7	79.5	81.0	84.9	90.5	77.6	79.1	82.8	88.4	75.7	77.2	80.8	86.2	71.9	73.3	76.8	81.9	66.6	67.9	71.1	75.9
	S/T	0.89	0.86	0.78	0.63	0.93	0.89	0.81	0.65	0.95	0.92	0.83	0.67	0.98	0.95	0.85	0.69	1.00	0.98	0.89	0.72	1.00	0.99	0.89	0.72
	ΔT	28	27	26	22	28	28	26	23	28	28	26	23	28	28	26	23	28	28	26	23	26	26	24	21
	kW	6.07	6.19	6.37	6.6	6.51	6.64	6.83	7.0	6.89	7.03	7.24	7.5	7.22	7.37	7.60	7.8	7.51	7.67	7.91	8.2	7.76	7.92	8.17	8.4
	Hi PR	231	249	263	274	260	279	295	308	295	318	335	350	336	362	382	399	378	407	430	448	418	450	475	495
Lo PR	107	114	124	133	113	120	131	140	118	125	137	146	124	131	144	153	130	138	150	160	134	143	156	166	

IDB: Entering Indoor Dry Bulb Temperature
 High and low pressures are measured at the liquid and suction access fittings.
 Shaded area reflects AHRI Rating Conditions
 Design Superheat 7±2 °F; Design Subcooling 12 ±2 °F; pressures measured @ the suction and liquid service ports, AHRI 95 test conditions
 Amps: Unit amps (comp.+ evaporator + condenser fan motors)

IDB		OUTDOOR AMBIENT TEMPERATURE																																																																																																																																																																																																																																																																																																																																																																											
		65								75								85								95								105								115																																																																																																																																																																																																																																																																																																																																			
		AIRFLOW						ENTERING INDOOR WET BULB TEMPERATURE						ENTERING INDOOR WET BULB TEMPERATURE						ENTERING INDOOR WET BULB TEMPERATURE						ENTERING INDOOR WET BULB TEMPERATURE						ENTERING INDOOR WET BULB TEMPERATURE																																																																																																																																																																																																																																																																																																																																													
59	63	67	71	59	63	67	71	59	63	67	71	59	63	67	71	59	63	67	71	59	63	67	71	59	63	67	71	59	63	67	71	59	63	67	71	59	63	67	71																																																																																																																																																																																																																																																																																																																																						
70	MBh	100.0	103.6	113.5	-	97.6	101.2	110.9	-	95.3	98.8	108.2	-	93.0	96.4	105.6	-	88.3	91.6	100.3	-	81.8	84.8	92.9	-	0.69	0.58	0.40	-	0.72	0.60	0.42	-	0.74	0.62	0.43	-	0.76	0.64	0.44	-	0.79	0.66	0.46	-	8.90	8.90	8.90	-	8.90	8.90	8.90	-	8.90	8.90	8.90	-	8.90	8.90	8.90	-	8.90	8.90	8.90	-	8.90	8.90	8.90	-	245	263	278	-	274	295	312	-	312	336	355	-	355	382	404	-	400	430	454	-	442	475	502	-	104	110	120	-	109	116	127	-	114	121	132	-	119	127	139	-	125	133	145	-	130	138	150	-	97.0	100.6	110.2	-	94.8	98.2	107.6	-	92.5	95.9	105.1	-	90.3	93.6	102.5	-	85.8	88.9	97.4	-	79.4	82.3	90.2	-	0.66	0.55	0.38	-	0.69	0.57	0.40	-	0.70	0.59	0.41	-	0.73	0.61	0.42	-	0.75	0.63	0.44	-	0.76	0.63	0.44	-	8.90	8.90	8.90	-	8.90	8.90	8.90	-	8.90	8.90	8.90	-	8.90	8.90	8.90	-	8.90	8.90	8.90	-	8.90	8.90	8.90	-	242	261	275	-	272	292	309	-	309	332	351	-	352	379	400	-	396	426	450	-	437	471	497	-	103	109	119	-	108	115	126	-	113	120	131	-	118	126	137	-	124	132	144	-	128	136	149	-	89.6	92.8	101.7	-	87.5	90.7	99.3	-	85.4	88.5	97.0	-	83.3	86.4	94.6	-	79.2	82.0	89.9	-	73.3	76.0	83.3	-	0.64	0.53	0.37	-	0.66	0.55	0.38	-	0.68	0.57	0.39	-	0.70	0.58	0.41	-	0.73	0.61	0.42	-	0.73	0.61	0.42	-	8.90	8.90	8.90	-	8.90	8.90	8.90	-	8.90	8.90	8.90	-	8.90	8.90	8.90	-	8.90	8.90	8.90	-	8.90	8.90	8.90	-	235	253	267	-	264	284	299	-	300	323	341	-	341	367	388	-	384	413	436	-	424	457	482	-	99	106	116	-	105	112	122	-	109	116	127	-	115	122	133	-	120	128	140	-	124	132	144	-								
	3600	S/T	0.69	0.58	0.40	-	0.72	0.60	0.42	-	0.74	0.62	0.43	-	0.76	0.64	0.44	-	0.79	0.66	0.46	-	0.80	0.67	0.46	-	8.90	8.90	8.90	-	8.90	8.90	8.90	-	8.90	8.90	8.90	-	8.90	8.90	8.90	-	8.90	8.90	8.90	-	8.90	8.90	8.90	-	245	263	278	-	274	295	312	-	312	336	355	-	355	382	404	-	400	430	454	-	442	475	502	-	104	110	120	-	109	116	127	-	114	121	132	-	119	127	139	-	125	133	145	-	130	138	150	-	97.0	100.6	110.2	-	94.8	98.2	107.6	-	92.5	95.9	105.1	-	90.3	93.6	102.5	-	85.8	88.9	97.4	-	79.4	82.3	90.2	-	0.66	0.55	0.38	-	0.69	0.57	0.40	-	0.70	0.59	0.41	-	0.73	0.61	0.42	-	0.75	0.63	0.44	-	0.76	0.63	0.44	-	8.90	8.90	8.90	-	8.90	8.90	8.90	-	8.90	8.90	8.90	-	8.90	8.90	8.90	-	8.90	8.90	8.90	-	8.90	8.90	8.90	-	242	261	275	-	272	292	309	-	309	332	351	-	352	379	400	-	396	426	450	-	437	471	497	-	103	109	119	-	108	115	126	-	113	120	131	-	118	126	137	-	124	132	144	-	128	136	149	-	89.6	92.8	101.7	-	87.5	90.7	99.3	-	85.4	88.5	97.0	-	83.3	86.4	94.6	-	79.2	82.0	89.9	-	73.3	76.0	83.3	-	0.64	0.53	0.37	-	0.66	0.55	0.38	-	0.68	0.57	0.39	-	0.70	0.58	0.41	-	0.73	0.61	0.42	-	0.73	0.61	0.42	-	8.90	8.90	8.90	-	8.90	8.90	8.90	-	8.90	8.90	8.90	-	8.90	8.90	8.90	-	8.90	8.90	8.90	-	8.90	8.90	8.90	-	235	253	267	-	264	284	299	-	300	323	341	-	341	367	388	-	384	413	436	-	424	457	482	-	99	106	116	-	105	112	122	-	109	116	127	-	115	122	133	-	120	128	140	-	124	132	144	-																											
	75	MBh	101.6	104.7	113.3	121.6	99.3	102.2	110.6	118.8	96.9	99.8	108.0	115.9	94.6	97.4	105.4	113.1	89.8	92.5	100.1	107.4	83.2	85.7	92.7	99.5	0.79	0.71	0.53	0.34	0.82	0.73	0.55	0.36	0.84	0.75	0.57	0.37	0.87	0.77	0.59	0.38	0.90	0.80	0.61	0.39	0.91	0.81	0.61	0.39	8.90	8.90	8.90	8.90	8.90	8.90	8.90	8.90	8.90	8.90	8.90	8.90	8.90	8.90	8.90	8.90	8.90	8.90	8.90	8.90	8.90	8.90	8.90	8.90	8.90	247	266	281	293	277	298	315	329	315	339	358	374	359	386	408	426	404	435	459	479	446	480	507	529	105	111	122	129	111	118	128	137	115	122	133	142	121	128	140	149	126	135	147	156	131	139	152	162	98.7	101.6	110.0	118.0	96.4	99.2	107.4	115.3	94.1	96.9	104.9	112.5	91.8	94.5	102.3	109.8	87.2	89.8	97.2	104.3	80.8	83.2	90.0	96.6	0.75	0.67	0.51	0.33	0.78	0.70	0.53	0.34	0.80	0.72	0.54	0.35	0.83	0.74	0.56	0.36	0.86	0.77	0.58	0.37	0.86	0.77	0.58	0.38	8.90	8.90	8.90	8.90	8.90	8.90	8.90	8.90	8.90	8.90	8.90	8.90	8.90	8.90	8.90	8.90	8.90	8.90	8.90	8.90	8.90	8.90	8.90	8.90	8.90	245	263	278	290	274	295	312	325	312	336	355	370	355	383	404	421	400	430	454	474	442	476	502	524	104	110	120	128	109	116	127	135	114	121	132	141	120	127	139	148	125	133	145	155	130	138	150	160	91.1	93.8	101.5	108.9	89.0	91.6	99.1	106.4	86.8	89.4	96.8	103.9	84.7	87.2	94.4	101.3	80.5	82.9	89.7	96.3	74.6	76.8	83.1	89.2	0.73	0.65	0.49	0.32	0.75	0.67	0.51	0.33	0.77	0.69	0.52	0.34	0.80	0.71	0.54	0.35	0.83	0.74	0.56	0.36	0.83	0.74	0.56	0.36	8.90	8.90	8.90	8.90	8.90	8.90	8.90	8.90	8.90	8.90	8.90	8.90	8.90	8.90	8.90	8.90	8.90	8.90	8.90	8.90	8.90	8.90	8.90	8.90	8.90	237	255	270	281	266	286	303	316	303	326	344	359	345	371	392	409	388	417	441	460	429	461	487	508	101	107	117	124	106	113	123	131	110	117	128	137	116	123	135	143	121	129	141	150	126	134	146	155

IDB: Entering Indoor Dry Bulb Temperature
 High and low pressures are measured at the liquid and suction access fittings.
 Shaded area reflects ACCA (TVA) Rating Conditions
 Design Superheat 7±2 °F, Design Subcooling 12 ±2 °F, pressures measured @ the suction and liquid service ports, AHRI 95 test conditions
 Amps: Unit amps (comp. + evaporator + condenser fan motors)

IDB		OUTDOOR AMBIENT TEMPERATURE																							
		65				75				85				95				105				115			
		59	63	67	71	59	63	67	71	59	63	67	71	59	63	67	71	59	63	67	71	59	63	67	71
3600		103.5	105.7	112.9	120.7	101.0	103.3	110.3	117.9	98.6	100.8	107.7	115.1	96.2	98.3	105.1	112.3	91.4	93.4	99.8	106.7	84.7	86.5	92.5	98.8
S/T		0.87	0.81	0.66	0.49	0.90	0.84	0.68	0.51	0.92	0.86	0.70	0.52	0.95	0.89	0.72	0.54	1.00	0.92	0.75	0.56	1.00	0.93	0.76	0.57
ΔT		23	22	19	15	23	22	19	15	23	22	19	15	23	22	19	16	23	22	19	15	22	21	18	14
kW		8.90	8.90	8.90	8.90	8.90	8.90	8.90	8.90	8.90	8.90	8.90	8.90	8.90	8.90	8.90	8.90	8.90	8.90	8.90	8.90	8.90	8.90	8.90	8.90
HI PR		250	269	284	296	280	301	318	332	318	343	362	377	363	390	412	430	408	439	464	484	451	485	512	534
LO PR		106	112	123	131	112	119	130	138	116	123	135	144	122	130	142	151	128	136	148	158	132	141	153	163
80		100.4	102.6	109.7	117.2	98.1	100.2	107.1	114.5	95.8	97.9	104.6	111.8	93.4	95.5	102.0	109.0	88.8	90.7	96.9	103.6	82.2	84.0	89.8	96.0
S/T		0.83	0.77	0.63	0.47	0.86	0.80	0.65	0.49	0.88	0.82	0.67	0.50	0.91	0.85	0.69	0.52	0.94	0.88	0.72	0.54	0.95	0.89	0.72	0.54
ΔT		24	23	20	16	24	23	20	16	24	23	20	16	24	23	20	16	24	23	20	16	22	21	19	15
kW		8.90	8.90	8.90	8.90	8.90	8.90	8.90	8.90	8.90	8.90	8.90	8.90	8.90	8.90	8.90	8.90	8.90	8.90	8.90	8.90	8.90	8.90	8.90	8.90
HI PR		247	266	281	293	277	298	315	329	315	339	358	374	359	386	408	426	404	435	459	479	446	480	507	529
LO PR		105	111	122	129	111	118	128	137	115	122	133	142	121	128	140	149	127	135	147	156	131	139	152	162
2800		92.7	94.7	101.2	108.2	90.5	92.5	98.9	105.7	88.4	90.3	96.5	103.2	86.2	88.1	94.1	100.6	81.9	83.7	89.4	95.6	75.9	77.5	82.8	88.6
S/T		0.80	0.75	0.61	0.45	0.82	0.77	0.63	0.47	0.85	0.79	0.65	0.48	0.87	0.82	0.67	0.50	0.91	0.85	0.69	0.52	0.91	0.86	0.70	0.52
ΔT		24	23	20	16	25	23	20	16	25	24	20	16	25	24	21	16	24	23	20	16	23	22	19	15
kW		8.90	8.90	8.90	8.90	8.90	8.90	8.90	8.90	8.90	8.90	8.90	8.90	8.90	8.90	8.90	8.90	8.90	8.90	8.90	8.90	8.90	8.90	8.90	8.90
HI PR		240	258	272	284	269	289	306	319	306	329	348	362	348	375	396	413	392	422	445	464	433	466	492	513
LO PR		102	108	118	126	107	114	125	133	111	119	129	138	117	125	136	145	123	131	143	152	127	135	147	157

3600		105.3	107.3	112.4	119.9	102.8	104.8	109.8	117.1	100.4	102.3	107.1	114.3	97.9	99.8	104.5	111.5	93.0	94.8	99.3	105.9	86.2	87.8	92.0	98.1
S/T		0.91	0.88	0.79	0.64	0.94	0.91	0.82	0.66	0.96	0.93	0.84	0.68	0.99	0.96	0.87	0.70	1.00	1.00	0.90	0.73	1.00	1.00	0.91	0.74
ΔT		24	24	23	20	25	24	23	20	25	24	23	20	25	24	23	20	24	24	23	20	22	22	21	18
kW		8.90	8.90	8.90	8.90	8.90	8.90	8.90	8.90	8.90	8.90	8.90	8.90	8.90	8.90	8.90	8.90	8.90	8.90	8.90	8.90	8.90	8.90	8.90	8.90
HI PR		252	271	286	299	283	304	321	335	322	346	365	381	366	394	416	434	412	443	468	488	455	490	517	540
LO PR		107	114	124	132	113	120	131	140	117	125	136	145	123	131	143	152	129	137	150	160	133	142	155	165
85		102.2	104.2	109.1	116.4	99.8	101.7	106.6	113.7	97.4	99.3	104.0	111.0	95.1	96.9	101.5	108.3	90.3	92.1	96.4	102.9	83.7	85.3	89.3	95.3
S/T		0.87	0.83	0.75	0.61	0.90	0.86	0.78	0.63	0.92	0.89	0.80	0.65	0.95	0.92	0.83	0.67	0.98	0.95	0.86	0.70	0.99	0.96	0.86	0.70
ΔT		25	25	24	20	26	25	24	21	26	25	24	21	26	25	24	21	26	25	24	21	24	23	22	19
kW		8.90	8.90	8.90	8.90	8.90	8.90	8.90	8.90	8.90	8.90	8.90	8.90	8.90	8.90	8.90	8.90	8.90	8.90	8.90	8.90	8.90	8.90	8.90	8.90
HI PR		250	269	284	296	280	301	318	332	318	343	362	377	363	390	412	430	408	439	464	484	451	485	512	534
LO PR		106	112	123	131	112	119	130	138	116	123	135	144	122	130	142	151	128	136	148	158	132	141	153	163
2800		94.3	96.2	100.7	107.4	92.1	93.9	98.4	104.9	89.9	91.7	96.0	102.4	87.7	89.4	93.7	99.9	83.4	85.0	89.0	94.9	77.2	78.7	82.4	87.9
S/T		0.83	0.80	0.73	0.59	0.86	0.83	0.75	0.61	0.89	0.86	0.77	0.63	0.91	0.88	0.80	0.65	0.95	0.92	0.83	0.67	0.96	0.92	0.83	0.68
ΔT		26	25	24	21	26	26	24	21	26	26	24	21	26	26	25	21	26	26	24	21	24	24	23	20
kW		8.90	8.90	8.90	8.90	8.90	8.90	8.90	8.90	8.90	8.90	8.90	8.90	8.90	8.90	8.90	8.90	8.90	8.90	8.90	8.90	8.90	8.90	8.90	8.90
HI PR		242	260	275	287	272	292	309	322	309	332	351	366	352	379	400	417	396	426	450	469	437	471	497	518
LO PR		103	109	119	127	108	115	126	134	113	120	131	139	118	126	137	146	124	132	144	153	128	136	149	159

IDB: Entering Indoor Dry Bulb Temperature
 High and low pressures are measured at the liquid and suction access fittings.
 Shaded area reflects AHRI Rating Conditions
 Design Superheat 7±2 °F, Design Subcooling 12 ±2 °F, pressures measured @ the suction and liquid service ports, AHRI 95 test conditions
 Amps: Unit amps (comp. + evaporator + condenser fan motors)

IDB		OUTDOOR AMBIENT TEMPERATURE																											
		65				75				85				95				105				115							
		59	63	67	71	59	63	67	71	59	63	67	71	59	63	67	71	59	63	67	71	59	63	67	71				
		ENTERING INDOOR WET BULB TEMPERATURE																											
AIRFLOW		59	63	67	71	59	63	67	71	59	63	67	71	59	63	67	71	59	63	67	71	59	63	67	71	59	63	67	71
70	MBh	114	118	129	-	111	115	126	-	108	112	123	-	106	110	120	-	100	104	114	-	100	104	114	-	93	96	106	-
	S/T	0.73	0.61	0.42	-	0.76	0.63	0.44	-	0.78	0.65	0.45	-	0.80	0.67	0.47	-	0.83	0.70	0.48	-	0.83	0.70	0.48	-	0.84	0.70	0.49	-
	ΔT	19	17	13	-	20	17	13	-	20	17	13	-	20	17	13	-	20	17	13	-	20	17	13	-	18	16	12	-
	kW	8.22	8.37	8.60	-	8.77	8.94	9.19	-	9.25	9.43	9.70	-	9.68	9.87	10.16	-	10.04	10.24	10.55	-	10.04	10.24	10.55	-	10.36	10.56	10.88	-
	Hi PR	247	266	281	-	277	298	315	-	315	339	358	-	359	386	408	-	404	435	459	-	404	435	459	-	446	480	507	-
Lo PR	105	111	122	-	111	118	128	-	115	122	134	-	121	128	140	-	127	135	147	-	127	135	147	-	131	139	152	-	
3500	MBh	110	114	125	-	108	112	122	-	105	109	119	-	103	106	117	-	98	101	111	-	98	101	111	-	90	94	103	-
	S/T	0.70	0.58	0.40	-	0.72	0.61	0.42	-	0.74	0.62	0.43	-	0.77	0.64	0.44	-	0.80	0.66	0.46	-	0.80	0.66	0.46	-	0.80	0.67	0.46	-
	ΔT	20.27	17.55	13.32	-	20.52	17.76	13.48	-	20.54	17.78	13.50	-	20.69	17.91	13.59	-	20.40	17.66	13.40	-	20.40	17.66	13.40	-	19.05	16.49	12.52	-
	kW	8.2	8.3	8.5	-	8.7	8.9	9.1	-	9.2	9.4	9.6	-	9.6	9.8	10.1	-	10.0	10.2	10.5	-	10.0	10.2	10.5	-	10.3	10.5	10.8	-
	Hi PR	245	263	278	-	274	295	312	-	312	336	355	-	355	383	404	-	400	430	454	-	400	430	454	-	442	476	502	-
Lo PR	104	110	120	-	110	117	127	-	114	121	132	-	120	127	139	-	125	133	146	-	125	133	146	-	130	138	151	-	
2800	MBh	102	106	116	-	99	103	113	-	97	101	110	-	95	98	108	-	90	93	102	-	90	93	102	-	83	86	95	-
	S/T	0.67	0.56	0.39	-	0.70	0.58	0.40	-	0.72	0.60	0.41	-	0.74	0.62	0.43	-	0.77	0.64	0.44	-	0.77	0.64	0.44	-	0.77	0.65	0.45	-
	ΔT	23	20	15	-	23	20	15	-	23	20	15	-	23	20	15	-	23	20	15	-	23	20	15	-	21	18	14	-
	kW	8	8	8	-	9	9	9	-	9	9	9	-	9	10	10	-	10	10	10	-	10	10	10	-	10	10	11	-
	Hi PR	237	255	270	-	266	286	302	-	303	326	344	-	345	371	392	-	388	417	441	-	388	417	441	-	429	461	487	-
Lo PR	101	107	117	-	106	113	123	-	110	117	128	-	116	123	135	-	122	129	141	-	122	129	141	-	126	134	146	-	
3938	MBh	116	119	129	138	113	116	126	135	110	113	123	132	108	111	120	129	102	105	114	122	102	105	114	122	95	97	105	113
	S/T	0.83	0.75	0.56	0.4	0.86	0.77	0.58	0.4	0.89	0.79	0.60	0.4	0.91	0.82	0.62	0.4	0.95	0.85	0.64	0.4	0.95	0.85	0.64	0.4	0.96	0.86	0.65	0.4
	ΔT	22.5	20.7	17.0	11.7	22.8	21.0	17.2	11.9	22.8	21.0	17.2	11.9	23.0	21.1	17.3	12.0	22.6	20.8	17.1	11.8	22.6	20.8	17.1	11.8	21.1	19.5	15.9	11.0
	kW	8.3	8.4	8.7	8.9	8.8	9.0	9.3	9.5	9.3	9.5	9.8	10.1	9.8	9.9	10.2	10.5	10.1	10.3	10.6	10.9	10.1	10.3	10.6	10.9	10.4	10.6	11.0	11.3
	Hi PR	250	269	284	296	280	301	318	332	318	343	362	377	363	390	412	430	408	439	464	484	408	439	464	484	451	485	512	534
Lo PR	106	113	123	131	112	119	130	138	116	124	135	144	122	130	142	151	128	136	148	158	128	136	148	158	132	141	154	164	
75	MBh	112	116	125	134	110	113	122	131	107	110	119	128	104	107	116	125	99	102	111	119	99	102	111	119	92	95	102	110
	S/T	0.79	0.71	0.54	0.3	0.82	0.74	0.56	0.4	0.84	0.76	0.57	0.4	0.87	0.78	0.59	0.4	0.90	0.81	0.61	0.4	0.90	0.81	0.61	0.4	0.91	0.82	0.62	0.4
	ΔT	23.4	21.6	17.7	12.2	23.7	21.8	17.9	12.4	23.7	21.9	17.9	12.4	23.9	22.0	18.0	12.5	23.6	21.7	17.8	12.3	23.6	21.7	17.8	12.3	22.0	20.3	16.6	11.5
	kW	8.2	8.4	8.6	8.8	8.8	8.9	9.2	9.5	9.3	9.4	9.7	10.0	9.7	9.9	10.2	10.5	10.0	10.2	10.5	10.9	10.0	10.2	10.5	10.9	10.4	10.6	10.9	11.2
	Hi PR	247	266	281	293	277	298	315	329	315	339	358	374	359	386	408	426	404	435	459	479	404	435	459	479	446	480	507	529
Lo PR	105	111	122	130	111	118	128	137	115	122	134	142	121	128	140	149	127	135	147	157	127	135	147	157	131	139	152	162	
2800	MBh	104	107	115	124	101	104	113	121	99	102	110	118	96	99	107	115	92	94	102	109	92	94	102	109	85	87	95	101
	S/T	0.77	0.69	0.52	0.3	0.79	0.71	0.54	0.3	0.81	0.73	0.55	0.4	0.84	0.75	0.57	0.4	0.87	0.78	0.59	0.4	0.87	0.78	0.59	0.4	0.88	0.79	0.60	0.4
	ΔT	26.1	24.0	19.7	13.6	26.4	24.3	19.9	13.7	26.4	24.3	19.9	13.8	26.6	24.5	20.1	13.9	26.2	24.2	19.8	13.7	26.2	24.2	19.8	13.7	24.5	22.6	18.5	12.8
	kW	8.1	8.2	8.4	8.7	8.6	8.7	9.0	9.2	9.1	9.2	9.5	9.8	9.5	9.7	9.9	10.2	9.8	10.0	10.3	10.6	9.8	10.0	10.3	10.6	10.1	10.3	10.6	11.0
	Hi PR	240	258	272	284	269	289	306	319	306	329	348	362	348	375	396	413	392	422	445	464	392	422	445	464	433	466	492	513
Lo PR	102	108	118	126	107	114	125	133	112	119	130	138	117	125	136	145	123	131	143	152	123	131	143	152	127	135	148	157	

IDB: Entering Indoor Dry Bulb Temperature
 High and low pressures are measured at the liquid and suction access fittings.
 Shaded area reflects ACCA (TVA) Rating Conditions
 Design Superheat 7±2 °F, Design Subcooling 12 ±2 °F, pressures measured @ the suction and liquid service ports, AHRI 95 test conditions
 Amps: Unit amps (comp. + evaporator + condenser fan motors)

IDB		OUTDOOR AMBIENT TEMPERATURE																								
		65				75				85				95				105				115				
		59	63	67	71	59	63	67	71	59	63	67	71	59	63	67	71	59	63	67	71	59	63	67	71	
3938		MBh	118	120	128	137	115	117	125	134	112	115	122	131	109	112	119	128	104	106	114	121	96	98	105	112
		S/T	0.91	0.86	0.70	0.5	0.95	0.89	0.72	0.5	1.00	0.91	0.74	0.6	1.00	0.94	0.77	0.6	1.00	1.00	0.79	0.6	1.00	1.00	0.80	0.6
		ΔT	25.1	24.1	20.9	16.7	25.4	24.4	21.2	16.9	26.2	24.4	21.2	16.9	25.6	24.6	21.4	17.1	24.3	24.8	21.1	16.8	22.5	23.0	19.7	15.7
80		kW	8.34	8.49	8.73	9.0	8.90	9.07	9.32	9.6	9.39	9.57	9.85	10.1	9.83	10.02	10.31	10.6	10.20	10.40	10.71	11.0	10.52	10.73	11.05	11.4
		Hi PR	252	271	286	299	283	304	321	335	322	346	366	381	366	394	416	434	412	444	468	489	455	490	517	540
		Lo PR	107	114	124	132	113	120	131	140	117	125	136	145	123	131	143	152	129	137	150	160	134	142	155	165
		MBh	114	117	125	133	112	114	122	130	109	111	119	127	106	109	116	124	101	103	110	118	94	96	102	109
		S/T	0.87	0.82	0.67	0.50	0.90	0.85	0.69	0.52	0.93	0.87	0.71	0.53	0.96	0.90	0.73	0.55	0.99	0.93	0.76	0.57	1.00	0.94	0.76	0.57
		ΔT	26.16	25.07	21.80	17.4	26.48	25.38	22.07	17.6	26.51	25.40	22.09	17.6	26.69	25.58	22.24	17.8	26.32	25.22	21.93	17.5	24.56	23.56	20.49	16.4
		kW	8.3	8.4	8.7	8.9	8.8	9.0	9.3	9.5	9.3	9.5	9.8	10.1	9.8	9.9	10.2	10.5	10.1	10.3	10.6	11.0	10.4	10.6	11.0	11.3
		Hi PR	250	269	284	296	280	301	318	332	318	343	362	377	363	390	412	430	408	439	464	484	451	485	512	534
		Lo PR	106	113	123	131	112	119	130	138	116	124	135	144	122	130	142	151	128	136	149	158	132	141	154	164
		MBh	105	108	115	123	103	105	112	120	101	103	110	117	98	100	107	114	93	95	102	109	86	88	94	101
		S/T	0.84	0.79	0.64	0.5	0.87	0.82	0.67	0.5	0.89	0.84	0.68	0.5	0.92	0.86	0.70	0.5	0.96	0.90	0.73	0.5	0.97	0.91	0.74	0.6
		ΔT	29	28	24	19.4	29	28	25	19.6	29	28	25	19.6	30	28	25	19.8	29	28	24	19.5	27	26	23	18.2
		kW	8.1	8.3	8.5	8.7	8.6	8.8	9.1	9.3	9.1	9.3	9.6	9.8	9.5	9.7	10.0	10.3	9.9	10.1	10.4	10.7	10.2	10.4	10.7	11.0
		Hi PR	242	261	275	287	272	292	309	322	309	332	351	366	352	379	400	417	396	426	450	469	437	471	497	518
		Lo PR	103	109	119	127	108	115	126	134	113	120	131	139	118	126	137	146	124	132	144	153	128	136	149	159

		MBh	120	122	128	136	117	119	125	133	114	116	122	130	111	114	119	127	106	108	113	120	98	100	105	112
		S/T	0.96	0.92	0.83	0.7	0.99	0.96	0.86	0.7	1.00	0.98	0.89	0.7	1.00	1.00	0.92	0.7	1.00	1.00	0.95	0.8	1.00	1.00	0.96	0.8
		ΔT	26.8	26.3	24.9	21.6	27.1	26.7	25.2	21.8	26.7	26.7	25.2	21.8	26.0	26.5	25.4	22.0	24.7	25.2	25.1	21.7	22.9	23.3	23.4	20.3
		kW	8.40	8.55	8.79	9.0	8.96	9.13	9.39	9.7	9.46	9.64	9.92	10.2	9.90	10.09	10.39	10.7	10.27	10.48	10.79	11.1	10.59	10.81	11.13	11.5
		Hi PR	255	274	289	302	286	307	325	339	325	350	369	385	370	398	420	439	416	448	473	493	460	495	523	545
		Lo PR	108	115	125	133	114	121	132	141	118	126	138	147	124	132	145	154	130	139	151	161	135	144	157	167
		MBh	116	118	124	132	114	116	121	129	111	113	118	126	108	110	115	123	103	105	110	117	95	97	102	108
		S/T	0.91	0.88	0.80	0.65	0.95	0.91	0.82	0.67	0.97	0.94	0.85	0.69	1.00	0.97	0.87	0.71	1.00	1.00	0.91	0.74	1.00	1.00	0.91	0.74
		ΔT	27.90	27.44	25.94	22.5	28.24	27.78	26.26	22.7	28.27	27.81	26.28	22.8	28.40	28.00	26.47	22.9	26.98	27.50	26.10	22.6	24.99	25.47	24.38	21.1
		kW	8.3	8.5	8.7	9.0	8.9	9.1	9.3	9.6	9.4	9.6	9.8	10.1	9.8	10.0	10.3	10.6	10.2	10.4	10.7	11.0	10.5	10.7	11.0	11.4
		Hi PR	252	271	286	299	283	304	321	335	322	346	366	381	366	394	416	434	412	444	468	489	455	490	517	540
		Lo PR	107	114	124	132	113	120	131	140	117	125	136	145	123	131	143	152	129	137	150	160	134	142	155	165
		MBh	107	109	115	122	105	107	112	119	102	104	109	116	100	102	107	114	95	97	101	108	88	90	94	100
		S/T	0.88	0.85	0.77	0.6	0.91	0.88	0.80	0.6	0.94	0.90	0.82	0.7	0.97	0.93	0.84	0.7	1.00	0.97	0.87	0.7	1.00	0.98	0.88	0.7
		ΔT	31.0	30.5	28.9	25.0	31.4	30.9	29.2	25.3	31.5	30.9	29.2	25.3	31.7	31.2	29.4	25.5	31.1	30.7	29.0	25.1	28.8	28.7	27.1	23.5
		kW	8.2	8.3	8.5	8.8	8.7	8.9	9.1	9.4	9.2	9.4	9.6	9.9	9.6	9.8	10.1	10.4	10.0	10.2	10.5	10.8	10.3	10.5	10.8	11.1
		Hi PR	244	263	278	290	274	295	312	325	312	336	355	370	355	382	404	421	400	430	454	474	442	475	502	524
		Lo PR	104	110	120	128	109	116	127	135	114	121	132	141	120	127	139	148	125	133	145	155	130	138	150	160

IDB: Entering Indoor Dry Bulb Temperature
 High and low pressures are measured at the liquid and suction access fittings.
 Shaded area reflects AHRI Rating Conditions
 Design Superheat 7±2 °F; Design Subcooling 12 ±2 °F; pressures measured @ the suction and liquid service ports; AHRI 95 test conditions
 Amps: Unit amps (comp. + evaporator + condenser fan motors)

IDB		OUTDOOR AMBIENT TEMPERATURE																								
		65				75				85				95				105				115				
		59	63	67	71	59	63	67	71	59	63	67	71	59	63	67	71	59	63	67	71	59	63	67	71	
		ENTERING INDOOR WET BULB TEMPERATURE																								
		AIRFLOW																								
70	4725	MBh	139.1	144.1	157.9	-	135.8	140.8	154.2	-	132.6	137.4	150.6	-	129.4	134.1	146.9	-	122.9	127.4	139.5	-	113.8	118.0	129.3	-
		S/T	0.69	0.58	0.40	-	0.72	0.60	0.41	-	0.73	0.61	0.42	-	0.76	0.63	0.44	-	0.79	0.66	0.45	-	0.79	0.66	0.46	-
		ΔT	21	18	13	-	21	18	14	-	21	18	14	-	21	18	14	-	21	18	14	-	19	17	13	-
		kW	10.12	10.34	10.68	-	10.92	11.16	11.53	-	11.63	11.88	12.28	-	12.25	12.52	12.94	-	12.77	13.07	13.51	-	13.23	13.53	13.99	-
		HI PR	251	270	285	-	282	303	320	-	320	345	364	-	365	393	414	-	410	442	466	-	453	488	515	-
	LO PR	103	110	120	-	109	116	127	-	113	120	132	-	119	127	138	-	125	133	145	-	129	137	150	-	
70	4200	MBh	137.0	142.0	155.6	-	133.8	138.7	152.0	-	130.6	135.4	148.3	-	127.4	132.1	144.7	-	121.1	125.5	137.5	-	112.1	116.2	127.4	-
		S/T	0.66	0.55	0.38	-	0.69	0.57	0.40	-	0.70	0.59	0.41	-	0.73	0.61	0.42	-	0.75	0.63	0.44	-	0.76	0.63	0.44	-
		ΔT	21	18	14	-	22	19	14	-	22	19	14	-	22	19	14	-	21	19	14	-	20	17	13	-
		kW	10.07	10.28	10.62	-	10.86	11.10	11.46	-	11.56	11.82	12.21	-	12.17	12.45	12.87	-	12.70	12.99	13.43	-	13.15	13.45	13.91	-
		HI PR	249	268	283	-	280	301	318	-	318	342	361	-	362	390	412	-	407	439	463	-	450	485	512	-
	LO PR	102	109	119	-	108	115	126	-	112	120	131	-	118	126	137	-	124	132	144	-	128	136	149	-	
70	3360	MBh	130.1	134.9	147.8	-	127.1	131.8	144.4	-	124.1	128.6	140.9	-	121.1	125.5	137.5	-	115.0	119.2	130.6	-	106.5	110.4	121.0	-
		S/T	0.63	0.53	0.37	-	0.66	0.55	0.38	-	0.67	0.56	0.39	-	0.69	0.58	0.40	-	0.72	0.60	0.42	-	0.73	0.61	0.42	-
		ΔT	22	19	14	-	22	19	14	-	22	19	14	-	22	19	15	-	22	19	14	-	20	18	13	-
		kW	9.90	10.12	10.44	-	10.68	10.91	11.27	-	11.36	11.62	12.00	-	11.97	12.24	12.65	-	12.48	12.77	13.20	-	12.93	13.22	13.67	-
		HI PR	244	263	278	-	274	295	311	-	312	335	354	-	355	382	403	-	399	430	454	-	441	475	501	-
	LO PR	100	107	117	-	106	113	123	-	110	117	128	-	116	123	134	-	121	129	141	-	125	134	146	-	
75	4725	MBh	141.4	145.6	157.6	169.1	138.1	142.2	153.9	165.2	134.8	138.8	150.3	161.3	131.5	135.4	146.6	157.3	125.0	128.7	139.3	149.5	115.8	119.2	129.0	138.5
		S/T	0.78	0.70	0.53	0.34	0.81	0.73	0.55	0.35	0.83	0.75	0.56	0.36	0.86	0.77	0.58	0.37	0.89	0.80	0.60	0.39	0.90	0.81	0.61	0.39
		ΔT	24	22	18	12	24	22	18	13	24	22	18	13	24	22	18	13	24	22	18	12	22	21	17	12
		kW	10.21	10.43	10.77	11.12	11.01	11.26	11.63	12.02	11.72	11.99	12.39	12.81	12.35	12.63	13.06	13.50	12.89	13.18	13.63	14.09	13.35	13.65	14.12	14.61
		HI PR	254	273	288	300	284	306	323	337	324	348	368	383	368	397	419	437	415	446	471	491	458	493	520	543
	LO PR	104	111	121	129	110	117	128	136	114	122	133	142	120	128	140	149	126	134	146	156	130	139	151	161	
75	4200	MBh	139.3	143.4	155.3	166.6	136.1	140.1	151.7	162.8	132.8	136.8	148.0	158.9	129.6	133.4	144.4	155.0	123.1	126.8	137.2	147.3	114.0	117.4	127.1	136.4
		S/T	0.75	0.67	0.51	0.33	0.78	0.70	0.53	0.34	0.80	0.71	0.54	0.35	0.82	0.74	0.56	0.36	0.86	0.77	0.58	0.37	0.86	0.77	0.58	0.38
		ΔT	25	23	19	13	25	23	19	13	25	23	19	13	25	23	19	13	25	23	19	13	23	21	17	12
		kW	10.15	10.37	10.70	11.06	10.95	11.19	11.56	11.95	11.66	11.92	12.31	12.73	12.28	12.56	12.98	13.42	12.81	13.10	13.54	14.01	13.27	13.57	14.03	14.52
		HI PR	252	271	286	298	282	304	321	335	321	346	365	381	366	394	416	434	412	443	468	488	455	489	517	539
	LO PR	103	110	120	128	109	116	127	135	114	121	132	141	119	127	139	148	125	133	145	155	129	138	150	160	
75	3360	MBh	132.4	136.3	147.5	158.3	129.3	133.1	144.1	154.6	126.2	129.9	140.6	150.9	123.1	126.8	137.2	147.3	117.0	120.4	130.3	139.9	108.3	111.6	120.7	129.6
		S/T	0.72	0.64	0.49	0.31	0.75	0.67	0.50	0.32	0.76	0.68	0.52	0.33	0.79	0.71	0.53	0.34	0.82	0.73	0.55	0.36	0.83	0.74	0.56	0.36
		ΔT	25	23	19	13	25	23	19	13	25	23	19	13	26	24	19	13	25	23	19	13	24	22	18	12
		kW	9.98	10.20	10.53	10.87	10.77	11.01	11.37	11.74	11.46	11.72	12.10	12.51	12.07	12.34	12.76	13.19	12.59	12.88	13.31	13.77	13.04	13.34	13.79	14.26
		HI PR	247	265	280	292	277	298	315	328	315	339	358	373	359	386	407	425	403	434	458	478	446	480	507	528
	LO PR	101	108	118	125	107	114	124	133	111	118	129	138	117	124	136	145	123	130	142	152	127	135	147	157	

IDB: Entering Indoor Dry Bulb Temperature
 High and low pressures are measured at the liquid and suction access fittings.
 Shaded area reflects ACCA (TVA) Rating Conditions
 Design Superheat 7±2 °F; Design Subcooling 12 ±2 °F; pressures measured @ the suction and liquid service ports, AHRI 95 test conditions
 Amps: Unit amps (comp.+ evaporator + condenser fan motors)

IDB		OUTDOOR AMBIENT TEMPERATURE																													
		65					75					85					95					105					115				
		59	63	67	71	75	59	63	67	71	75	59	63	67	71	75	59	63	67	71	75	59	63	67	71	75	59	63	67	71	75
ENTERING INDOOR WET BULB TEMPERATURE																															
AIRFLOW	59	63	67	71	75	59	63	67	71	75	59	63	67	71	75	59	63	67	71	75	59	63	67	71	75	59	63	67	71	75	
4725	MBh	143.9	147.1	157.1	168.0	140.6	143.6	153.5	164.1	137.2	140.2	149.8	160.2	133.9	136.8	146.2	156.2	127.2	130.0	138.9	148.4	117.8	120.4	128.6	137.5						
	S/T	0.86	0.81	0.66	0.49	0.89	0.84	0.68	0.51	0.91	0.86	0.70	0.52	0.94	0.89	0.72	0.54	0.98	0.92	0.75	0.56	1.00	0.93	0.75	0.56						
	ΔT	26	25	22	18	27	26	22	18	27	26	22	18	27	26	23	18	27	26	22	18	25	24	21	17						
	kW	10.29	10.52	10.86	11.21	11.11	11.35	11.72	12.12	11.82	12.09	12.49	12.92	12.46	12.74	13.17	13.62	13.00	13.29	13.74	14.22	13.46	13.77	14.24	14.73						
	HI PR	256	276	291	303	287	309	327	341	327	352	371	387	372	401	423	441	419	451	476	496	463	498	526	548						
LO PR	105	112	122	130	111	118	129	138	116	123	134	143	121	129	141	150	127	135	148	157	132	140	153	163							
80	MBh	141.8	144.9	154.8	165.5	138.5	141.5	151.2	161.6	135.2	138.2	147.6	157.8	131.9	134.8	144.0	153.9	125.3	128.0	136.8	146.2	116.1	118.6	126.7	135.5						
	S/T	0.82	0.77	0.63	0.47	0.85	0.80	0.65	0.49	0.88	0.82	0.67	0.50	0.90	0.85	0.69	0.52	0.94	0.88	0.72	0.54	0.95	0.89	0.72	0.54						
	ΔT	28	26	23	18	28	27	23	19	28	27	23	19	28	27	23	19	28	27	23	18	26	25	22	17						
	kW	10.23	10.46	10.79	11.15	11.04	11.29	11.66	12.05	11.75	12.02	12.42	12.84	12.38	12.66	13.09	13.54	12.92	13.21	13.66	14.13	13.38	13.69	14.15	14.64						
	HI PR	254	274	289	301	285	307	324	338	325	349	369	385	370	398	420	438	416	447	473	493	459	494	522	545						
LO PR	105	111	121	129	110	117	128	137	115	122	133	142	121	128	140	149	126	134	147	156	131	139	152	162							
3360	MBh	134.7	137.6	147.1	157.2	131.6	134.4	143.6	153.6	128.4	131.2	140.2	149.9	125.3	128.0	136.8	146.2	119.0	121.6	130.0	138.9	110.3	112.7	120.4	128.7						
	S/T	0.79	0.74	0.60	0.45	0.82	0.77	0.62	0.47	0.84	0.79	0.64	0.48	0.87	0.81	0.66	0.49	0.90	0.84	0.69	0.51	0.91	0.85	0.69	0.52						
	ΔT	28	27	23	19	28	27	24	19	28	27	24	19	29	27	24	19	28	27	23	19	26	25	22	17						
	kW	10.07	10.28	10.62	10.96	10.86	11.10	11.46	11.84	11.56	11.82	12.21	12.62	12.17	12.45	12.87	13.31	12.70	12.99	13.43	13.89	13.15	13.45	13.91	14.39						
	HI PR	249	268	283	295	280	301	318	331	318	342	361	377	362	390	412	429	407	439	463	483	450	485	512	534						
LO PR	102	109	119	127	108	115	126	134	112	120	131	139	118	126	137	146	124	132	144	153	128	136	149	158							
4725	MBh	146.4	149.3	156.3	166.8	143.0	145.8	152.7	162.9	139.6	142.3	149.1	159.0	136.2	138.9	145.4	155.2	129.4	131.9	138.2	147.4	119.9	122.2	128.0	136.5						
	S/T	0.90	0.87	0.79	0.64	0.93	0.90	0.81	0.66	0.96	0.93	0.83	0.68	0.99	0.95	0.86	0.70	1.00	0.99	0.89	0.73	1.00	1.00	0.90	0.73						
	ΔT	28	28	26	23	29	28	27	23	29	28	27	23	29	28	27	23	28	28	26	23	26	26	25	21						
	kW	10.38	10.60	10.95	11.31	11.20	11.45	11.82	12.22	11.92	12.19	12.60	13.03	12.56	12.85	13.28	13.74	13.11	13.41	13.86	14.34	13.58	13.89	14.36	14.86						
	HI PR	259	278	294	307	290	312	330	344	330	355	375	391	376	405	427	446	423	455	481	501	467	503	531	554						
LO PR	106	113	123	131	112	119	130	139	117	124	136	144	123	130	142	152	128	137	149	159	133	141	154	164							
85	MBh	144.3	147.1	154.0	164.3	140.9	143.6	150.4	160.5	137.6	140.2	146.9	156.7	134.2	136.8	143.3	152.9	127.5	130.0	136.1	145.2	118.1	120.4	126.1	134.5						
	S/T	0.86	0.83	0.75	0.61	0.90	0.86	0.78	0.63	0.92	0.89	0.80	0.65	0.95	0.91	0.83	0.67	0.98	0.95	0.86	0.69	0.99	0.96	0.86	0.70						
	ΔT	29	29	27	24	30	29	28	24	30	29	28	24	30	29	28	24	30	29	27	24	28	27	26	22						
	kW	10.32	10.54	10.88	11.24	11.13	11.38	11.75	12.15	11.85	12.12	12.52	12.95	12.49	12.77	13.20	13.65	13.03	13.33	13.78	14.25	13.50	13.81	14.28	14.77						
	HI PR	257	276	292	304	288	310	327	342	328	353	372	388	373	402	424	442	420	452	477	498	464	499	527	550						
LO PR	106	112	123	131	112	119	130	138	116	123	135	143	122	130	141	151	128	136	148	158	132	140	153	163							
3360	MBh	137.1	139.7	146.3	156.1	133.9	136.5	142.9	152.5	130.7	133.2	139.5	148.8	127.5	130.0	136.1	145.2	121.1	123.5	129.3	138.0	112.2	114.4	119.8	127.8						
	S/T	0.83	0.80	0.72	0.58	0.86	0.83	0.75	0.61	0.88	0.85	0.77	0.62	0.91	0.88	0.79	0.64	0.94	0.91	0.82	0.67	0.95	0.92	0.83	0.67						
	ΔT	30	29	28	24	30	30	28	24	30	30	28	24	30	30	28	24	30	29	28	24	28	28	26	23						
	kW	10.15	10.37	10.70	11.06	10.95	11.19	11.56	11.94	11.65	11.91	12.31	12.73	12.28	12.55	12.98	13.42	12.81	13.10	13.54	14.01	13.26	13.57	14.03	14.51						
	HI PR	252	271	286	298	282	304	321	335	321	346	365	381	366	394	416	434	412	443	468	488	455	489	517	539						
LO PR	103	110	120	128	109	116	127	135	114	121	132	140	119	127	139	148	125	133	145	155	129	138	150	160							

IDB: Entering Indoor Dry Bulb Temperature
 High and low pressures are measured at the liquid and suction access fittings.
 Shaded area reflects AHRI Rating Conditions
 Design Superheat 7±2 °F. Design Subcooling 12 ±2 °F. pressures measured @ the suction and liquid service ports, AHRI 95 test conditions
 Amps: Unit amps (comp. + evaporator + condenser fan motors)

STANDARD BELT DRIVE & TWO-SPEED STANDARD BELT DRIVE AT HIGH SPEED — DOWN SHOT

ESP (" W.C.)	TURNS OPEN																	
	0			1			2			3			4			5		
	CFM	RPM	BHP	CFM	RPM	BHP	CFM	RPM	BHP	CFM	RPM	BHP	CFM	RPM	BHP	CFM	RPM	BHP
0.1	---	---	---	---	---	---	---	---	---	---	---	---	3617	704	1.07	3293	653	0.84
0.3	---	---	---	---	---	---	---	---	---	3541	749	1.15	3179	704	0.88	2757	656	0.66
0.5	---	---	---	---	---	---	3447	798	1.23	3049	754	0.94	2606	710	0.71	---	---	---
0.7	---	---	---	3400	848	1.33	2950	798	1.01	2474	754	0.75	---	---	---	---	---	---
0.9	3303	890	1.41	2871	848	1.11	2408	804	0.82	---	---	---	---	---	---	---	---	---
1.1	2838	897	1.23	---	---	---	---	---	---	---	---	---	---	---	---	---	---	---

HIGH-STATIC BELT DRIVE — DOWN SHOT

ESP (" W.C.)	TURNS OPEN																				
	0			1			2			3			4			5					
	CFM	RPM	BHP	CFM	RPM	BHP	CFM	RPM	BHP	CFM	RPM	BHP	CFM	RPM	BHP	CFM	RPM	BHP			
0.9	DO NOT OPERATE			---	---	---	---	---	---	---	---	---	---	---	---	3401	909	1.51			
1.1				---	---	---	---	---	---	---	---	---	---	---	3428	965	1.71	2943	915	1.3	
1.3				---	---	---	---	---	---	---	---	3471	1015	1.9	3012	971	1.5	2423	920	1.12	
1.5				---	---	---	---	---	3722	1063	2.25	3041	1023	1.67	2503	976	1.31	---	---	---	
1.7				---	---	---	---	---	3359	1075	2.04	2540	1031	1.5	---	---	---	---	---	---	
1.9				---	---	---	3381	1119	2.22	2890	1080	1.78	---	---	---	---	---	---	---	---	---
2.1				---	---	---	3089	1129	2.04	---	---	---	---	---	---	---	---	---	---	---	---

STANDARD BELT DRIVE & TWO-SPEED STANDARD BELT DRIVE AT HIGH SPEED — HORIZONTAL

ESP (" W.C.)	TURNS OPEN																	
	0			1			2			3			4			5		
	CFM	RPM	BHP	CFM	RPM	BHP	CFM	RPM	BHP	CFM	RPM	BHP	CFM	RPM	BHP	CFM	RPM	BHP
0.1	---	---	---	---	---	---	---	---	---	---	---	---	3625	701	1.08	3309	660	0.86
0.3	---	---	---	---	---	---	3815	797	1.44	3468	747	1.11	3177	703	0.88	2796	663	0.68
0.5	---	---	---	3780	841	1.52	3405	803	1.23	3053	753	0.94	2608	709	0.68	2225	665	0.53
0.7	3687	885	1.6	3327	847	1.29	2968	805	1.02	2423	758	0.73	---	---	---	---	---	---
0.9	3236	891	1.39	2850	852	1.1	2352	807	0.8	---	---	---	---	---	---	---	---	---
1.1	2713	896	1.17	---	---	---	---	---	---	---	---	---	---	---	---	---	---	---

HIGH-STATIC BELT DRIVE — HORIZONTAL

ESP (" W.C.)	TURNS OPEN																			
	0			1			2			3			4			5				
	CFM	RPM	BHP	CFM	RPM	BHP	CFM	RPM	BHP	CFM	RPM	BHP	CFM	RPM	BHP	CFM	RPM	BHP		
0.9	DO NOT OPERATE			---	---	---	---	---	---	---	---	---	---	---	---	3447	902	1.54		
1.1				---	---	---	---	---	---	---	---	---	---	---	3398	956	1.65	3006	908	1.31
1.3				---	---	---	---	---	---	---	---	3486	1008	1.87	2960	962	1.44	---	---	---
1.5				---	---	---	---	---	3514	1057	2.07	2949	1019	1.62	---	---	---	---	---	---
1.7				---	---	---	3388	1103	2.18	3036	1069	1.84	---	---	---	---	---	---	---	---
1.9				---	---	---	2959	1114	2.0	---	---	---	---	---	---	---	---	---	---	---
2.1				---	---	---	2527	1124	1.86	---	---	---	---	---	---	---	---	---	---	---

NOTES

- Assume dry coil with filter in place; CFM correction for wet coil = 3%
- Any adjustment made to the blower should not cause the motor to draw more than the motor rated RLA. Applications that exceed the above could require a larger motor. Minimum rated SCFM is 350 per ton.

STANDARD BELT DRIVE & TWO-SPEED STANDARD BELT DRIVE AT HIGH SPEED — DOWN SHOT

ESP (" W.C.)	TURNS OPEN																	
	0			1			2			3			4			5		
	CFM	RPM	BHP	CFM	RPM	BHP	CFM	RPM	BHP	CFM	RPM	BHP	CFM	RPM	BHP	CFM	RPM	BHP
0.1	---	---	---	---	---	---	---	---	---	---	---	---	3467	701	1.04	3143	650	0.81
0.3	---	---	---	---	---	---	---	---	---	3391	746	1.12	3029	701	0.85	2607	653	0.63
0.5	---	---	---	---	---	---	3297	795	1.20	2899	751	0.91	2456	707	0.68	---	---	---
0.7	---	---	---	3250	845	1.30	2800	795	0.98	---	---	---	---	---	---	---	---	---
0.9	3153	887	1.38	2721	845	1.08	---	---	---	---	---	---	---	---	---	---	---	---
1.1	2688	894	1.20	---	---	---	---	---	---	---	---	---	---	---	---	---	---	---

HIGH-STATIC BELT-DRIVE — DOWN SHOT

ESP (" W.C.)	TURNS OPEN																	
	0			1			2			3			4			5		
	CFM	RPM	BHP	CFM	RPM	BHP	CFM	RPM	BHP	CFM	RPM	BHP	CFM	RPM	BHP	CFM	RPM	BHP
0.9	---	---	---	---	---	---	---	---	---	---	---	---	---	---	---	3251	906	1.48
1.1	---	---	---	---	---	---	---	---	---	---	---	---	3278	962	1.68	2793	912	1.27
1.3	---	---	---	---	---	---	---	---	---	3321	1012	1.87	2862	968	1.47	---	---	---
1.5	---	---	---	---	---	---	3572	1060	2.22	2891	1020	1.64	---	---	---	---	---	---
1.7	---	---	---	---	---	---	3209	1072	2.01	---	---	---	---	---	---	---	---	---
1.9	---	---	---	3231	1116	2.19	2740	1077	1.75	---	---	---	---	---	---	---	---	---
2.1	3256	1156	2.31	2939	1126	2.01	---	---	---	---	---	---	---	---	---	---	---	---

STANDARD BELT DRIVE & TWO-SPEED STANDARD BELT DRIVE AT HIGH SPEED --- HORIZONTAL

ESP (" W.C.)	TURNS OPEN																	
	0			1			2			3			4			5		
	CFM	RPM	BHP	CFM	RPM	BHP	CFM	RPM	BHP	CFM	RPM	BHP	CFM	RPM	BHP	CFM	RPM	BHP
0.1	---	---	---	---	---	---	---	---	---	---	---	---	3475	698	1.05	3159	657	0.83
0.3	---	---	---	---	---	---	3665	794	1.41	3318	744	1.08	3027	700	0.85	2646	660	0.65
0.5	---	---	---	3630	838	1.49	3255	800	1.2	2903	750	0.91	2458	706	0.65	---	---	---
0.7	3537	882	1.57	3177	844	1.26	2818	802	0.99	---	---	---	---	---	---	---	---	---
0.9	3086	888	1.36	2700	849	1.07	---	---	---	---	---	---	---	---	---	---	---	---
1.1	2563	893	1.14	---	---	---	---	---	---	---	---	---	---	---	---	---	---	---

HIGH-STATIC BELT-DRIVE — HORIZONTAL

ESP (" W.C.)	TURNS OPEN																	
	0			1			2			3			4			5		
	CFM	RPM	BHP	CFM	RPM	BHP	CFM	RPM	BHP	CFM	RPM	BHP	CFM	RPM	BHP	CFM	RPM	BHP
0.9	---	---	---	---	---	---	---	---	---	---	---	---	---	---	---	3297	899	1.51
1.1	---	---	---	---	---	---	---	---	---	---	---	---	3248	953	1.62	2856	905	1.28
1.3	---	---	---	---	---	---	---	---	---	3336	1005	1.84	2810	959	1.41	---	---	---
1.5	---	---	---	---	---	---	3364	1054	2.04	2799	1016	1.59	---	---	---	---	---	---
1.7	---	---	---	3238	1100	2.15	2886	1066	1.81	---	---	---	---	---	---	---	---	---
1.9	3188	1146	2.23	2809	1111	1.97	---	---	---	---	---	---	---	---	---	---	---	---

NOTES

- Assume dry coil with filter in place; CFM correction for wet coil = 3%
- Any adjustment made to the blower should not cause the motor to draw more than the motor rated RLA. Applications that exceed the above could require a larger motor. Minimum rated SCFM is 350 per ton.

STANDARD BELT DRIVE & TWO-SPEED STANDARD BELT-DRIVE AT HIGH SPEED — DOWN SHOT

ESP (" W.C.)	TURNS OPEN																	
	0			1			2			3			4			5		
	CFM	RPM	BHP	CFM	RPM	BHP	CFM	RPM	BHP	CFM	RPM	BHP	CFM	RPM	BHP	CFM	RPM	BHP
0.2	---	---	---	---	---	---	4632	781	1.76	4203	742	1.41	3927	691	1.17	3510	658	0.9
0.4	---	---	---	4488	825	1.85	4183	783	1.54	3733	748	1.23	3512	693	1	---	---	---
0.6	4442	880	2.02	4066	830	1.63	3717	786	1.31	---	---	---	---	---	---	---	---	---
0.8	4001	885	1.77	3622	835	1.41	---	---	---	---	---	---	---	---	---	---	---	---
1	3603	890	1.55	---	---	---	---	---	---	---	---	---	---	---	---	---	---	---
1.2	---	---	---	---	---	---	---	---	---	---	---	---	---	---	---	---	---	---

HIGH-STATIC BELT-DRIVE — DOWN SHOT

ESP (" W.C.)	TURNS OPEN																	
	0			1			2			3			4			5		
	CFM	RPM	BHP	CFM	RPM	BHP	CFM	RPM	BHP	CFM	RPM	BHP	CFM	RPM	BHP	CFM	RPM	BHP
0.8	---	---	---	---	---	---	---	---	---	---	---	---	4435	940	2.22	4078	886	1.82
1	---	---	---	---	---	---	---	---	---	4462	997	2.47	4103	945	2.05	3539	892	1.52
1.2	---	---	---	---	---	---	4513	1054	2.75	4127	1003	2.26	3568	950	1.71	---	---	---
1.4	---	---	---	---	---	---	4126	1064	2.52	3597	1008	1.92	---	---	---	---	---	---
1.6	---	---	---	4438	1116	2.97	3759	1069	2.25	---	---	---	---	---	---	---	---	---
1.8	---	---	---	3956	1124	2.55	---	---	---	---	---	---	---	---	---	---	---	---
2	4050	1179	3.05	3473	1132	2.32	---	---	---	---	---	---	---	---	---	---	---	---

STANDARD BELT DRIVE & TWO-SPEED STANDARD BELT-DRIVE AT HIGH SPEED — HORIZONTAL

ESP (" W.C.)	TURNS OPEN																	
	0			1			2			3			4			5		
	CFM	RPM	BHP	CFM	RPM	BHP	CFM	RPM	BHP	CFM	RPM	BHP	CFM	RPM	BHP	CFM	RPM	BHP
0.2	---	---	---	---	---	---	---	---	---	4562	736	1.58	4253	691	1.29	3893	642	1
0.4	---	---	---	---	---	---	4497	780	1.7	4200	736	1.41	3735	691	1.06	3322	648	0.83
0.6	---	---	---	4467	824	1.81	4221	784	1.55	3689	741	1.18	---	---	---	---	---	---
0.8	4564	873	2.06	4170	830	1.68	3677	785	1.29	---	---	---	---	---	---	---	---	---
1	4129	875	1.81	3498	835	1.34	---	---	---	---	---	---	---	---	---	---	---	---
1.2	3558	879	1.49	---	---	---	---	---	---	---	---	---	---	---	---	---	---	---

HIGH-STATIC BELT-DRIVE — HORIZONTAL

ESP (" W.C.)	TURNS OPEN																			
	0			1			2			3			4			5				
	CFM	RPM	BHP	CFM	RPM	BHP	CFM	RPM	BHP	CFM	RPM	BHP	CFM	RPM	BHP	CFM	RPM	BHP		
0.8	DO NOT OPERATE			---	---	---	---	---	---	---	---	---	---	---	---	4602	884	2.13		
1				---	---	---	---	---	---	---	---	---	---	4749	940	2.44	4180	885	1.89	
1.2				---	---	---	---	---	---	---	---	---	---	4251	945	2.12	3642	896	1.58	
1.4				---	---	---	---	---	---	---	---	4443	1001	2.5	3744	951	1.8	---	---	---
1.6				---	---	---	---	---	---	---	---	4587	1056	2.82	3971	1006	2.17	---	---	---
1.8				---	---	---	4760	1105	3.23	4071	1061	2.43	3342	1012	1.86	---	---	---	---	---
2				---	---	---	4364	1114	2.91	3579	1067	2.05	---	---	---	---	---	---	---	---

NOTES

- Assume dry coil with filter in place; CFM correction for wet coil = 3%
- Any adjustment made to the blower should not cause the motor to draw more than the motor rated RLA. Applications that exceed the above could require a larger motor. Minimum rated SCFM is 350 per ton.

STANDARD BELT DRIVE & TWO-SPEED STANDARD BELT DRIVE AT HIGH SPEED --- DOWN SHOT

ESP (" W.C.)	TURNS OPEN											
	0		1		2		3		4		5	
	CFM	BHP	CFM	BHP	CFM	BHP	CFM	BHP	CFM	BHP	CFM	BHP
0.2	---	---	---	---	5378	2.35	4967	1.92	4710	1.59	4512	1.33
0.4	5514	2.92	5349	2.56	4750	1.97	4583	1.71	4319	1.40	4030	1.13
0.6	5204	2.69	4919	2.27	4488	1.81	4258	1.54	---	---	---	---
0.8	4830	2.42	4649	2.09	4019	1.55	---	---	---	---	---	---
1.0	4497	2.19	4264	1.86	---	---	---	---	---	---	---	---

HIGH-STATIC BELT DRIVE --- DOWN SHOT

ESP (" W.C.)	TURNS OPEN											
	0		1		2		3		4		5	
	CFM	BHP	CFM	BHP	CFM	BHP	CFM	BHP	CFM	BHP	CFM	BHP
0.8	---	---	---	---	---	---	5978	3.87	5691	3.38	5324	2.81
1.0	---	---	---	---	5947	4.16	5656	3.58	5376	3.12	4933	2.52
1.2	---	---	---	---	5708	3.93	5459	3.40	4950	2.79	4441	2.18
1.4	5776	4.64	5510	4.07	5245	3.48	4844	2.88	4525	2.45	---	---
1.6	5465	4.30	5199	3.74	4894	3.17	4404	2.54	---	---	---	---
1.8	5145	3.97	4871	3.41	4495	2.83	---	---	---	---	---	---
2.0	4805	3.63	4565	3.13	4142	2.55	---	---	---	---	---	---
2.2	4429	3.27	4233	2.85	---	---	---	---	---	---	---	---

STANDARD BELT DRIVE & TWO-SPEED STANDARD BELT DRIVE AT HIGH SPEED --- HORIZONTAL

ESP (" W.C.)	TURNS OPEN											
	0		1		2		3		4		5	
	CFM	BHP	CFM	BHP	CFM	BHP	CFM	BHP	CFM	BHP	CFM	BHP
0.2	---	---	---	---	---	---	5570	2.27	4935	1.70	4584	1.36
0.4	5871	3.20	5639	2.77	5307	2.31	4902	1.88	4637	1.55	4178	1.19
0.6	5610	3.00	5358	2.57	5051	2.15	4603	1.72	4341	1.41	---	---
0.8	5391	2.83	5010	2.33	4799	2.00	4393	1.61	---	---	---	---
1.0	5078	2.59	4676	2.11	4448	1.79	---	---	---	---	---	---
1.2	4521	2.20	4226	1.83	---	---	---	---	---	---	---	---

HIGH-STATIC BELT DRIVE --- HORIZONTAL

ESP (" W.C.)	TURNS OPEN											
	0		1		2		3		4		5	
	CFM	BHP	CFM	BHP	CFM	BHP	CFM	BHP	CFM	BHP	CFM	BHP
0.8	---	---	---	---	---	---	---	---	5858	3.51	5538	2.97
1.0	---	---	---	---	---	---	5894	3.85	5502	3.20	5282	2.78
1.2	---	---	---	---	5780	4.04	5570	3.55	5110	2.88	4869	2.47
1.4	---	---	5900	4.49	5501	3.77	5312	3.33	4793	2.64	4598	2.28
1.6	5860	4.76	5514	4.08	5257	3.54	4945	3.01	4382	2.34	---	---
1.8	5615	4.49	5315	3.88	5020	3.32	4504	2.66	---	---	---	---
2.0	5529	4.40	4906	3.49	4601	2.96	---	---	---	---	---	---
2.2	4938	3.78	4541	3.15	4222	2.65	---	---	---	---	---	---

NOTES

- Assume dry coil with filter in place; CFM correction for wet coil = 3%
- Any adjustment made to the blower should not cause the motor to draw more than the motor rated RLA. Application that exceed the above could require a larger motor. Minimum rated SCFM is 350 per ton.

MODEL AND HEAT KIT USAGE	MCA ¹ AT 208 / 240V	MOP ² (AMPS) AT 208 / 240V	ACTUAL kW AT 240V	RECOMMENDED AIRFLOW RANGE
DCC090***3B/V***	37	50	---	---
EHK3-16	51	60	15	3000 - 3375 CFM
EHK3-30	97	100	30	3000 - 3375 CFM
EHK3-45	136	150	43	3000 - 3375 CFM

MODEL AND HEAT KIT USAGE	MCA ¹ AT 460V	MOP ² (AMPS) AT 460V	ACTUAL kW AT 460V	RECOMMENDED AIRFLOW RANGE
DCC090***4B/V***	18	20	---	---
EHK4-16	26	30	15	3000 - 3375 CFM
EHK4-30	48	50	30	3000 - 3375 CFM
EHK4-45	68	70	43	3000 - 3375 CFM

MODEL AND HEAT KIT USAGE	MCA ¹ AT 575V	MOP ² (AMPS) AT 575V	ACTUAL kW AT 575V	RECOMMENDED AIRFLOW RANGE
DCC090***7B/V***	13	15	---	---
EHK7-16	22	25	15	3000 - 3375 CFM
EHK7-30	41	45	30	3000 - 3375 CFM
EHK7-45	57	60	43	3000 - 3375 CFM

¹ Minimum Circuit Ampacity

² Maximum Overcurrent Protection device

kW CORRECTION FACTOR FOR 1- & 3-PHASE UNITS					
SUPPLY VOLTAGE	240	230	220	210	208
CORRECTION FACTOR	1	0.93	0.82	0.78	0.76

Multiply rated kW by correction factor to get actual kW

kW CORRECTION FACTOR FOR 480V UNITS			
ACTUAL VOLTAGE	460	440	430
CORRECTION FACTOR	0.92	0.84	0.8

For other voltage use $\text{voltage}^2 / 480^2$

kW CORRECTION FACTOR FOR 575V UNITS			
SUPPLY VOLTAGE	560	550	540
CORRECTION FACTOR	0.95	0.91	0.88

Multiply rated kW by correction factor to get actual kW

MINIMUM AIRFLOW FOR ELECTRIC HEAT

HEATER SIZE	MINIMUM CFM
15 kW	3,000
30 kW	3,000
43 kW	3,000

MODEL AND HEAT KIT USAGE	MCA ¹ AT 208 / 240V	MOP ² (AMPS) AT 208 / 240V	ACTUAL kW AT 240V	RECOMMENDED AIRFLOW RANGE (DOWNSHOT)	RECOMMENDED AIRFLOW RANGE (HORIZONTAL)
DCC102***3B/V***	43	50	---	---	---
EHK3-16	55	60	15	3400 - 3825 CFM	3400 - 3825 CFM
EHK3-30	100	100	30	3400 - 3825 CFM	3400 - 3825 CFM
EHK3-45	139	150	43	3400 - 3825 CFM	3400 - 3825 CFM

MODEL AND HEAT KIT USAGE	MCA ¹ AT 460V	MOP ² (AMPS) AT 460V	ACTUAL kW AT 460V	RECOMMENDED AIRFLOW RANGE (DOWNSHOT)	RECOMMENDED AIRFLOW RANGE (HORIZONTAL)
DCC102***4B/V***	20	25	---	---	---
EHK4-16	27	30	15	3400 - 3825 CFM	3400 - 3825 CFM
EHK4-30	50	50	30	3400 - 3825 CFM	3400 - 3825 CFM
EHK4-45	70	70	43	3400 - 3825 CFM	3400 - 3825 CFM

MODEL AND HEAT KIT USAGE	MCA ¹ AT 575V	MOP ² (AMPS) AT 575V	ACTUAL kW AT 575V	RECOMMENDED AIRFLOW RANGE (DOWNSHOT)	RECOMMENDED AIRFLOW RANGE (HORIZONTAL)
DCC102***7B/V***	17	20	---	---	---
EHK7-16	22	25	15	3400 - 3825 CFM	3400 - 3825 CFM
EHK7-30	41	45	30	3400 - 3825 CFM	3400 - 3825 CFM
EHK7-45	57	60	43	3400 - 3825 CFM	3400 - 3825 CFM

¹ Minimum Circuit Ampacity

² Maximum Overcurrent Protection device

^ - EHK Heater Kits above require a three-phase power supply

KW CORRECTION FACTORS

kW CORRECTION FACTOR FOR 1- & 3-PHASE UNITS					
SUPPLY VOLTAGE	240	230	220	210	208
CORRECTION FACTOR	1	0.93	0.82	0.78	0.76

kW CORRECTION FACTOR FOR 480V UNITS			
SUPPLY VOLTAGE	460	440	430
CORRECTION FACTOR	0.92	0.84	0.8

For other voltage, use $\text{voltage}^2 / 480^2$

kW CORRECTION FACTOR FOR 575V UNITS			
SUPPLY VOLTAGE	560	550	540
CORRECTION FACTOR	0.95	0.91	0.88

Multiply rated kW by correction factor to get actual kW.

MINIMUM AIRFLOW FOR ELECTRIC HEAT

HEATER SIZE (kW)	MIN. CFM DOWNSHOT	MIN. CFM HORIZONTAL
15	4,000	4,000
30	4,000	4,000
43	4,000	4,000

MODEL AND HEAT KIT USAGE	MCA ¹ AT 208 / 240V	MOP ² (AMPS) AT 208 / 240V	ACTUAL kW AT 240V	RECOMMENDED AIRFLOW RANGE
DCC120***3B/V***	49	60		
EHK3-16	48 / 55	50 / 60	15	3500 - 4500 CFM
EHK3-30	87 / 100	90 / 100	30	3500 - 4500 CFM
EHK3-45	121 / 139	125 / 150	43	4000 - 4500 CFM

MODEL AND HEAT KIT USAGE	MCA ¹ AT 460V	MOP ² (AMPS) AT 460V	ACTUAL kW AT 460V	RECOMMENDED AIRFLOW RANGE
DCC120***4B/V***	24	30		
EHK4-16	27	30	15	3500 - 4500 CFM
EHK4-30	50	50	30	3500 - 4500 CFM
EHK4-45	70	70	43	4000 - 4500 CFM

MODEL AND HEAT KIT USAGE	MCA ¹ AT 575V	MOP ² (AMPS) AT 575V	ACTUAL kW AT 575V	RECOMMENDED AIRFLOW RANGE
DCC120***7B/V***	17	20		
EHK7-16	22	25	15	3500 - 4500 CFM
EHK7-30	41	45	30	3500 - 4500 CFM
EHK7-45	57	60	43	4000 - 4500 CFM

¹ Minimum Circuit Ampacity

² Maximum Overcurrent Protection device

MODEL AND HEAT KIT USAGE	MCA ¹ AT 208 / 240V	MOP ² (AMPS) AT 208 / 240V	ACTUAL kW AT 240V	RECOMMENDED AIRFLOW RANGE
DCC150***3B/V***	65	80		
EHK3-16	65	80	15	4000 - 5600
EHK3-30	102	110	30	4300 - 5600
EHK3-45	141	150	43	4500 - 5600

MODEL AND HEAT KIT USAGE	MCA ¹ AT 460V	MOP ² (AMPS) AT 460V	ACTUAL kW AT 460V	RECOMMENDED AIRFLOW RANGE
DCC150***4B/V***	31	40		
EHK4-16	31	40	15	4000 - 5600
EHK4-30	51	60	30	4300 - 5600
EHK4-45	71	80	43	4500 - 5600

MODEL AND HEAT KIT USAGE	MCA ¹ AT 575V	MOP ² (AMPS) AT 575V	ACTUAL kW AT 575V	RECOMMENDED AIRFLOW RANGE
DCC150***7B/V***	23	30		
EHK7-16	24	30	15	4000 - 5600
EHK7-30	43	45	30	4300 - 5600
EHK7-45	59	60	43	4500 - 5600

¹ Minimum Circuit Ampacity (standard drive)

² Maximum Overcurrent Protection device (standard drive)

DIMENSIONS

MODEL TONNAGE	"A"	"B"
7.5 TON COMMERCIAL GAS, HT PUMP, AIR CONDITIONER	53.339	20.055
8.5 TON COMMERCIAL GAS, HT PUMP, AIR CONDITIONER	53.339	20.055
10 TON COMMERCIAL GAS, HT PUMP, AIR CONDITIONER	53.339	20.055
12.5 TON COMMERCIAL GAS, HT PUMP, AIR CONDITIONER	58.839	18.055

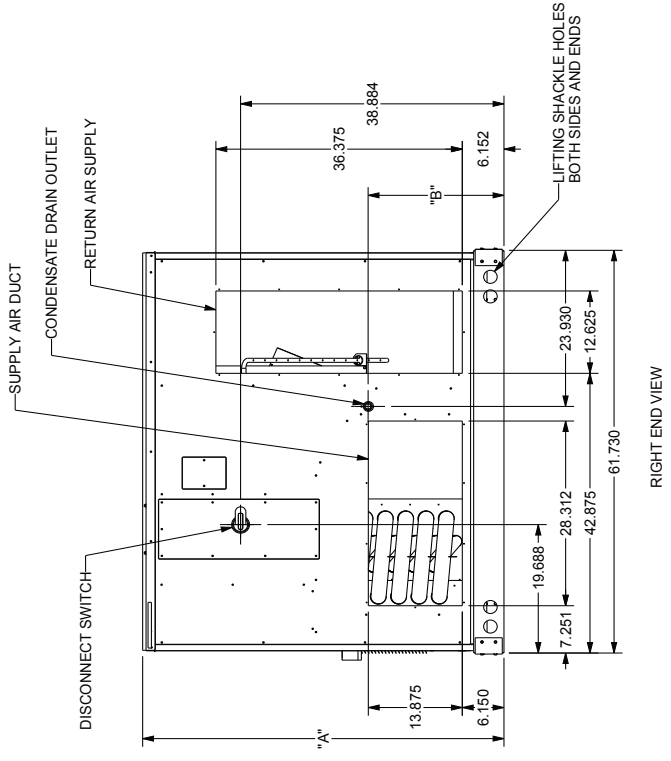
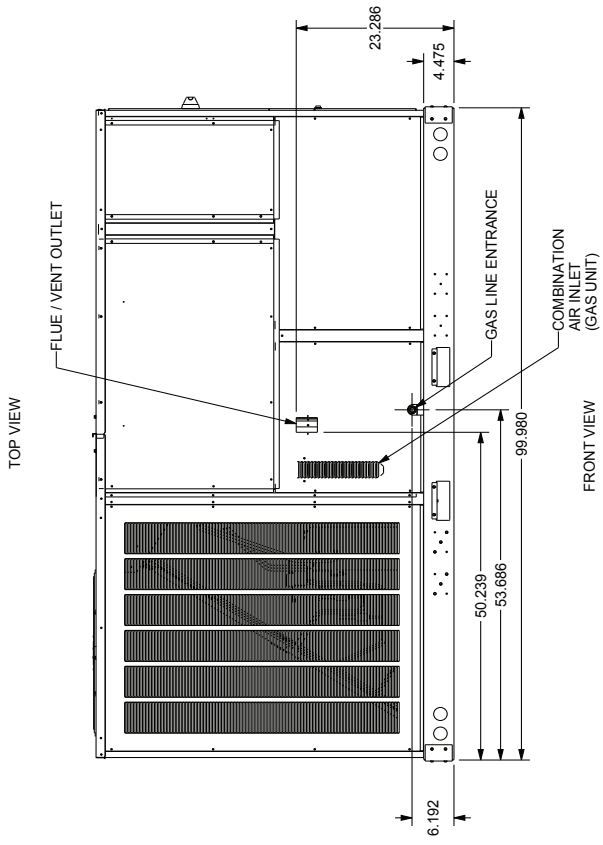
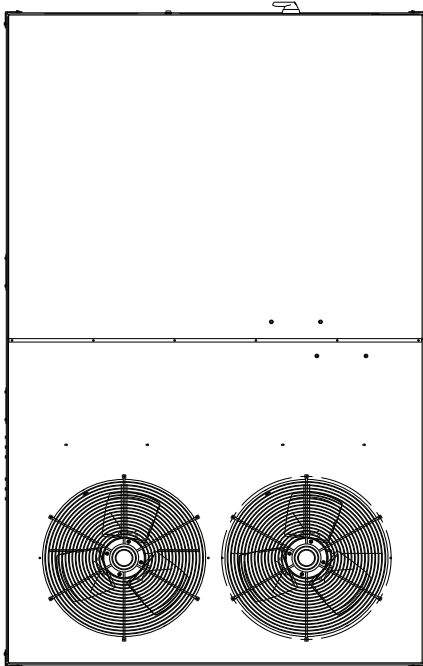

DC*090-150***
7.5 THRU 12.5 TON COMMERCIAL

ALL DIMENSIONS GIVEN ARE IN INCHES
ALL DIMENSIONS AND SPECIFICATIONS ARE SUBJECT TO CHANGE WITHOUT NOTICE

UNIT CLEARANCES

Maintain an adequate clearance around the unit for safety, service, maintenance, and proper unit operation. Leave a total clearance of 75" on the main control panel side of the unit for possible removal of fan shaft, coil, electric heat, and gas furnace. Leave a clearance of 48" on all other sides of the unit for possible compressor removal or service access, and to ensure proper ventilation and condenser airflow. Do not install the unit beneath any obstruction. Install the unit away from all building exhausts to inhibit ingestion of exhaust air into the unit's fresh-air intake.

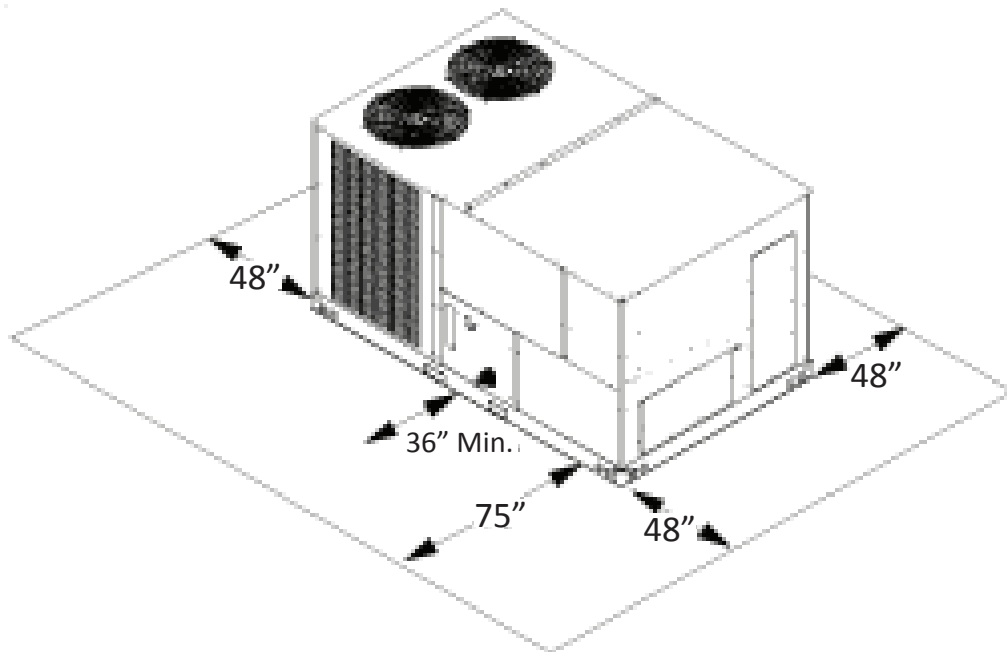

ELECTRICAL ENTRANCE LOCATIONS

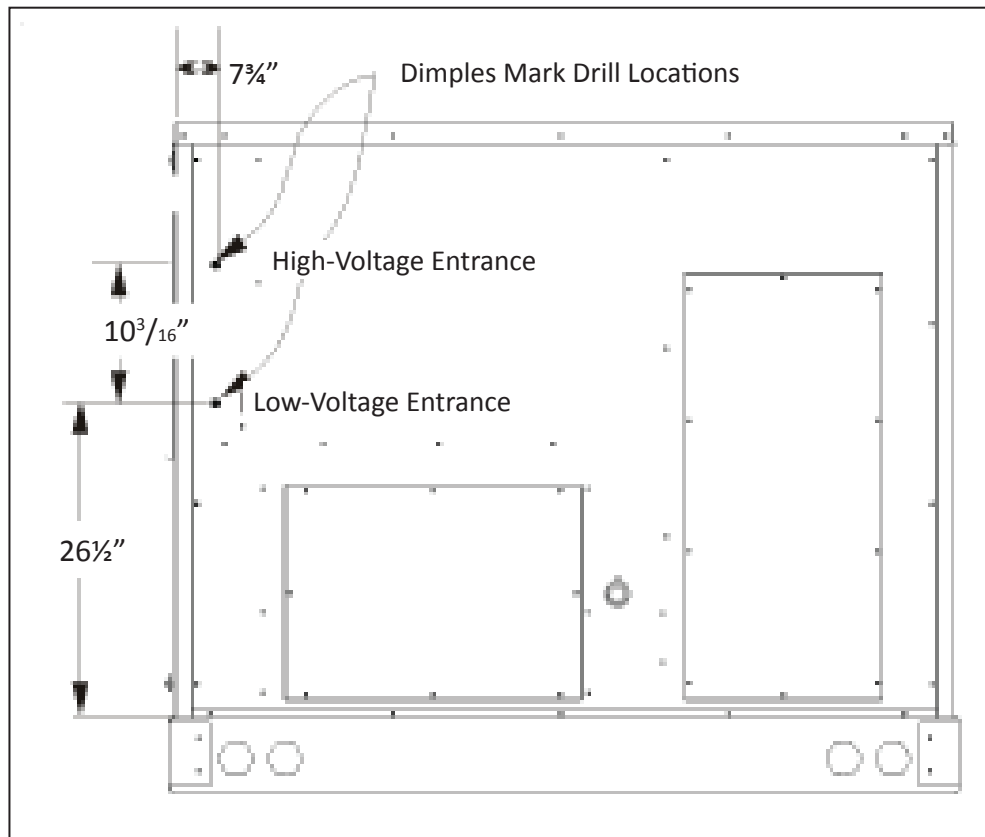

ROOF CURB INSTALLATION — RIGGING

Provisions for forks have been included in the unit base frame. No other fork locations are approved.

- Unit must be lifted by the four lifting holes located at the base frame corners.
- Lifting cables should be attached to the unit with shackles.
- The distance between the crane hook and the top of the unit must not be less than 60”.
- Two spreader bars must span over the unit to prevent damage to the cabinet by the lift cables. Spreader bars must be of sufficient length so that cables do not come in contact with the unit during transport. Remove wood struts mounted beneath unit base frame before setting unit on roof curb. These struts are intended to protect unit base frame from fork lift damage. To remove the struts, extract the sheet metal retainers and pull the struts through the base of the unit. Refer to rigging label on the unit.

Important: If using bottom discharge with roof curb, duct-work should be attached to the curb prior to installing the unit. Duct-work dimensions are shown in Roof Curb Installation Instructions Manual.

Refer to the Roof Curb Installation Instructions for proper curb installation. Curbing must be installed in compliance with the National Roofing Contractors Association Manual.

Lower unit carefully onto roof mounting curb. While rigging the unit, the center of gravity will cause the condenser end to be lower than the supply air end.

Bring condenser end of unit into alignment with the curb. With condenser end of the unit resting on curb member and using curb as a fulcrum, lower opposite end of the unit until entire unit is seated on the curb. When a rectangular cantilever curb is used, take care to center the unit. Check for proper alignment and orientation of supply and return openings with duct.

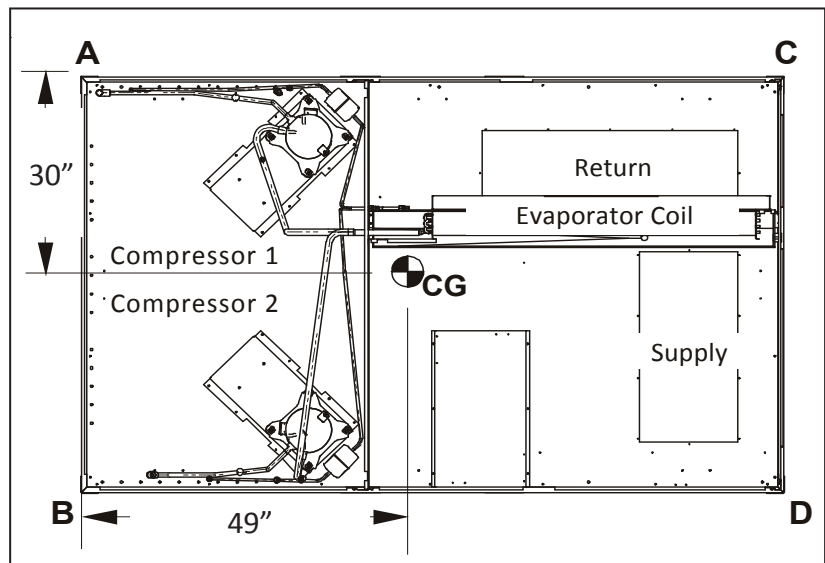
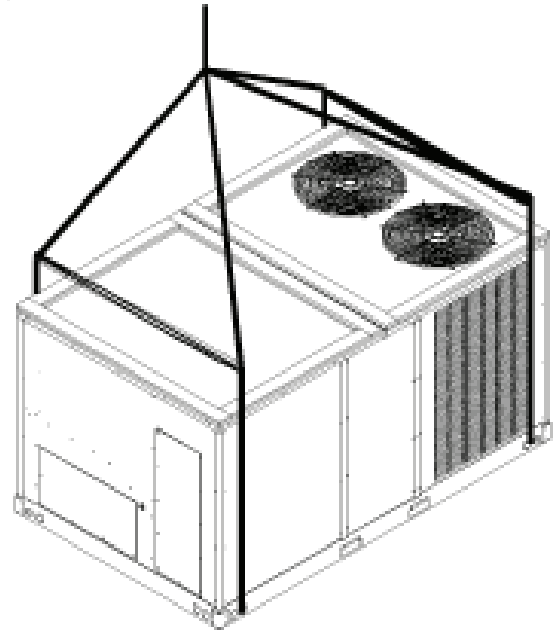

CORNER & CENTER-OF-GRAVITY LOCATIONS

UNIT WEIGHTS	7½-TON WEIGHTS (LBS)	8½-TON & 10-TON WEIGHTS (LBS)	12½-TON WEIGHTS (LBS)
Weight A	313	310	400
Weight B	248	263	315
Weight C	250	258	285
Weight D	199	219	225
Shipping Weight	1085	1125	1250
Operating Weight	1010	1050	1225

To assist in determining rigging requirements, unit weights are shown to the right.

Note: These weights are calculated without accessories installed.

ROOF CURB INSTALLATION (CONT.)

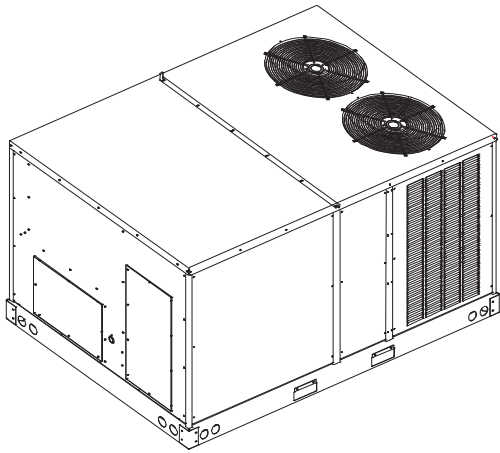

3-D VIEW

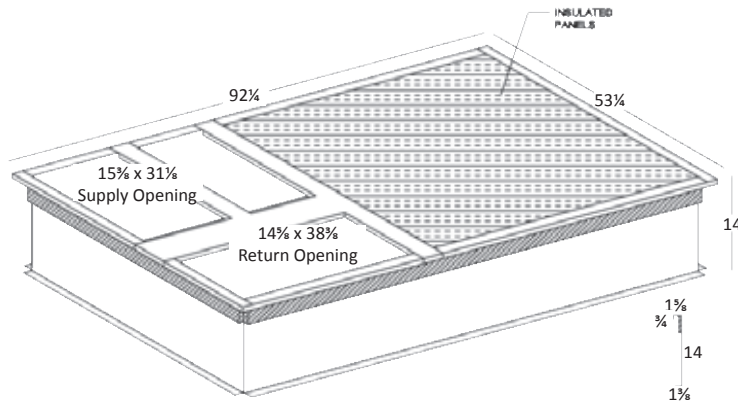

TOP VIEW

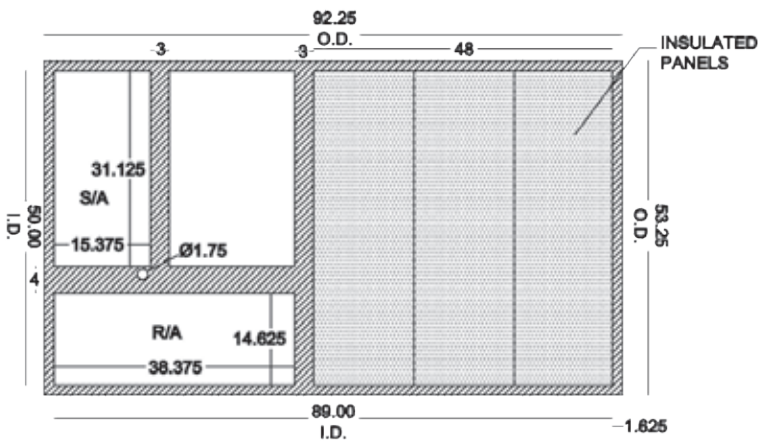

Curb installations must comply with local codes and should follow the established guidelines of the National Roofing Contractors Association. Proper unit installation requires that the roof curb be firmly and permanently attached to the roof structure. Check for adequate fastening method prior to setting the unit on the curb.

Full perimeter roof curbs are available from the factory and are shipped unassembled. The installing contractor is responsible for field assembly, squaring, leveling, and mounting on the roof structure. All required hardware necessary for the assembly of the sheet metal curb is included in the curb accessory package.

- Determine sufficient structural support before locating and mounting the curb and package unit.
- Duct-work must be constructed using industry guidelines. The duct-work must be placed into the roof curb before mounting the package unit. Our full perimeter curbs include duct connection frames to be assembled with the curb. Cantilevered-type curbs are not available from the factory.

- Contractor furnishes curb insulation, cant strips, flashing, and general roofing material.
- Support curbs on parallel sides with roof members. To prevent damage to the unit, the roof members cannot penetrate supply and return duct openings.

Note: The unit and curb accessories are designed to allow vertical duct installation before unit placement. Duct installation after unit placement is not recommended.

See the manual shipped with the roof curb for assembly and installation instructions.

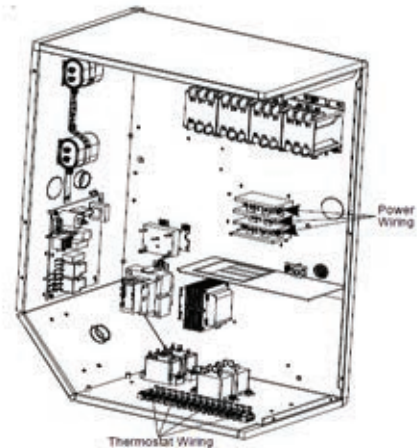

POWER AND LOW-VOLTAGE BLOCK LOCATIONS

DCC 7½-12½ TONS (230V/460V/575V THREE-PHASE BELT DRIVE)

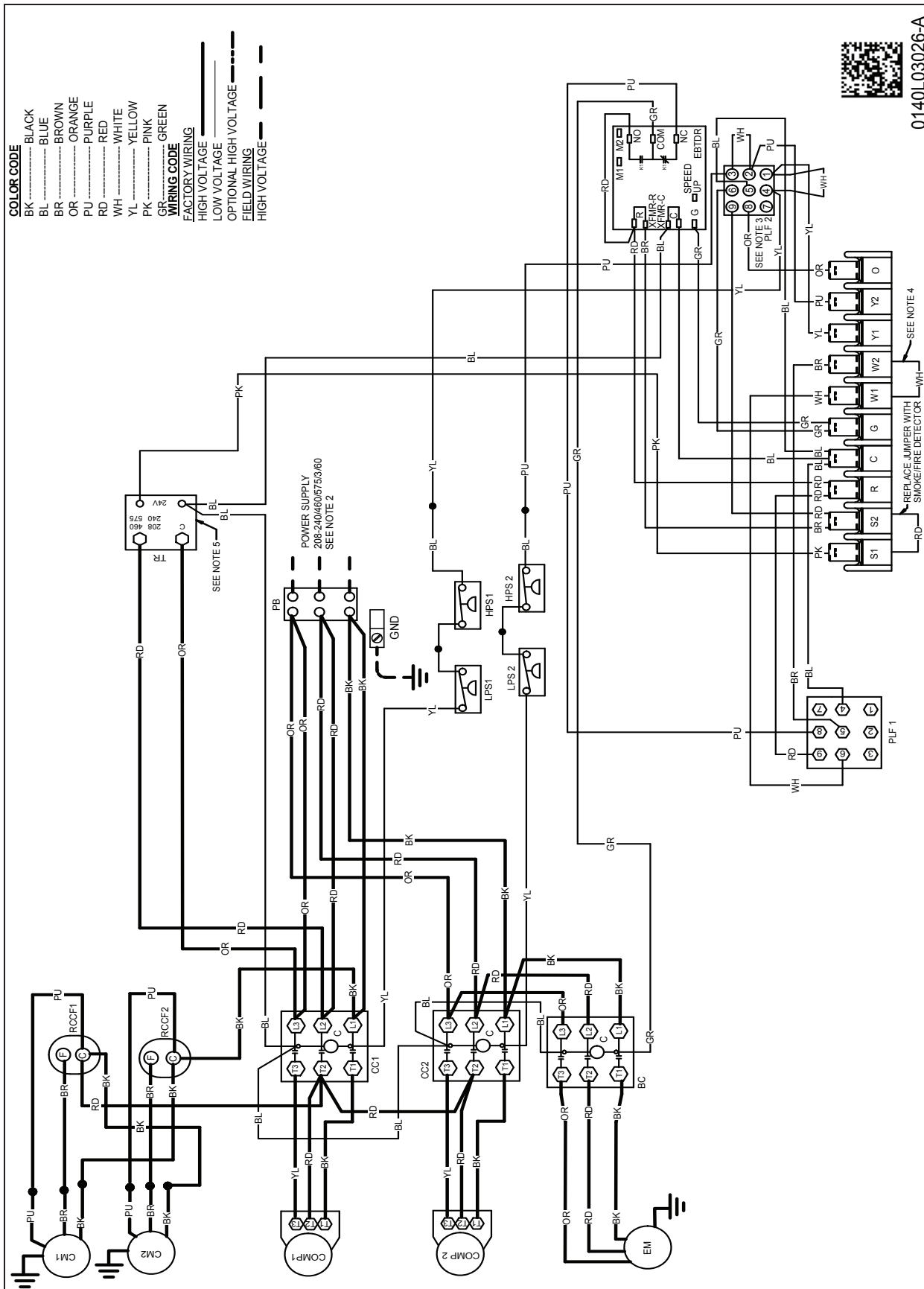

WARNING

High Voltage: Disconnect all power before servicing or installing this unit. Multiple power sources may be present. Failure to do so may cause property damage, personal injury, or death.

Wiring is subject to change. Always refer to the wiring diagram or the unit for the most up-to-date wiring.

DCC 7½-12½ TONS (230V/460V/575V THREE-PHASE BELT DRIVE)

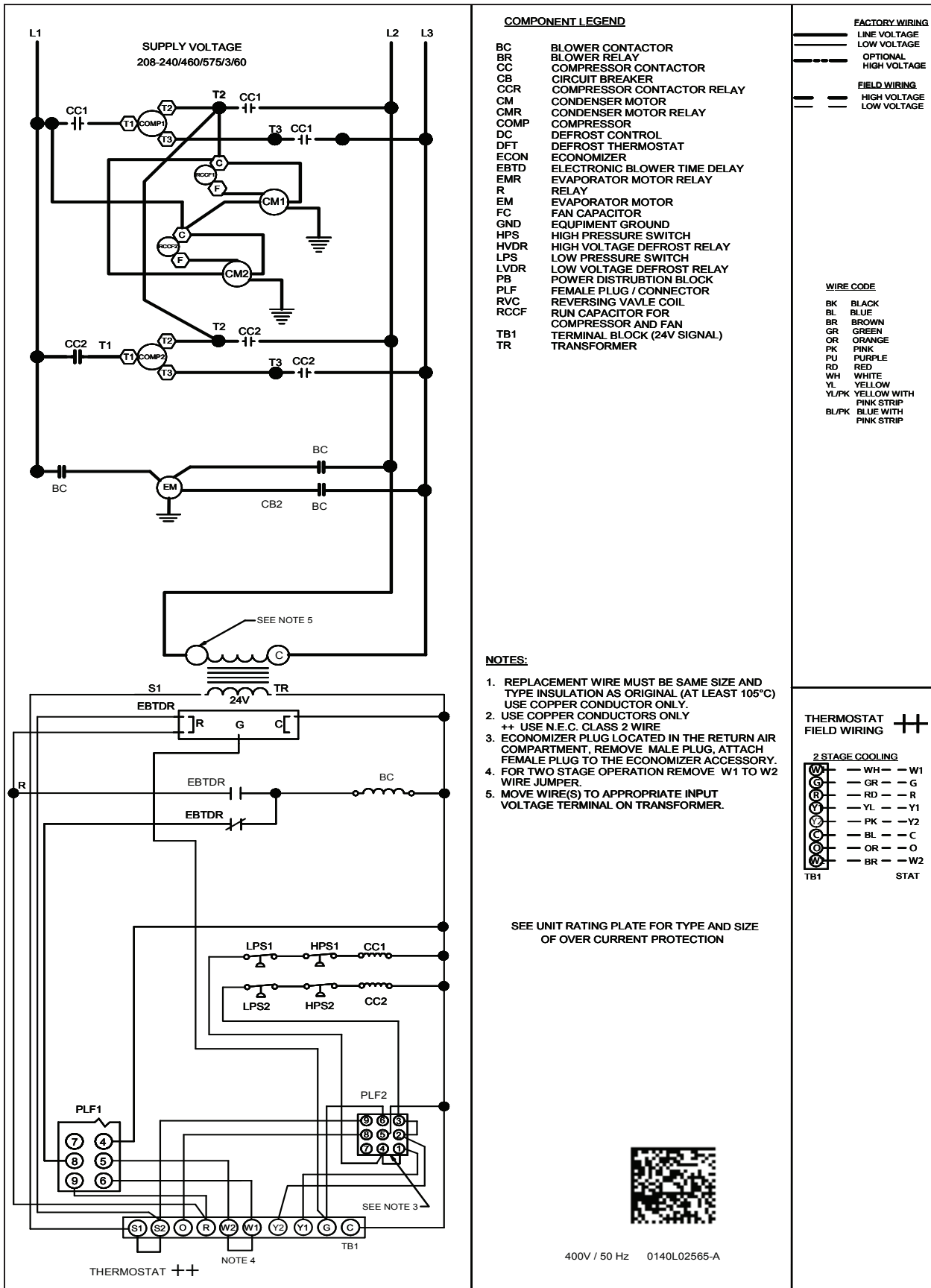

DCC 7½-8½ TONS (230V/460V/575V 2-SPEED, 3-PHASE BELT DRIVE)

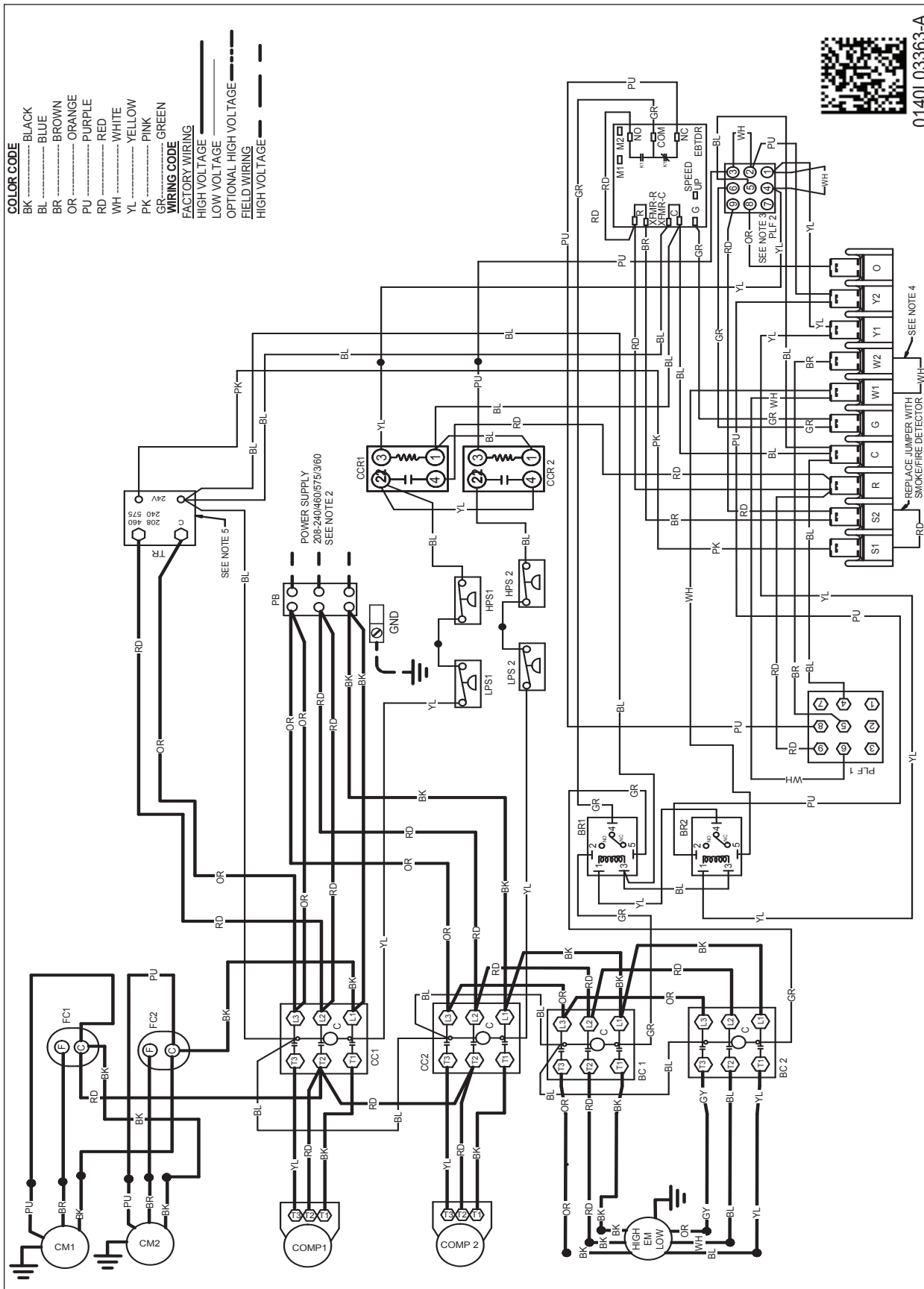

WARNING

⚡

High Voltage: Disconnect all power before servicing or installing this unit. Multiple power sources may be present. Failure to do so may cause property damage, personal injury, or death.

Wiring is subject to change. Always refer to the wiring diagram or the unit for the most up-to-date wiring.

DCC 7½-8½ TONS (230V/460V/575V 2-SPEED, 3-PHASE BELT DRIVE)

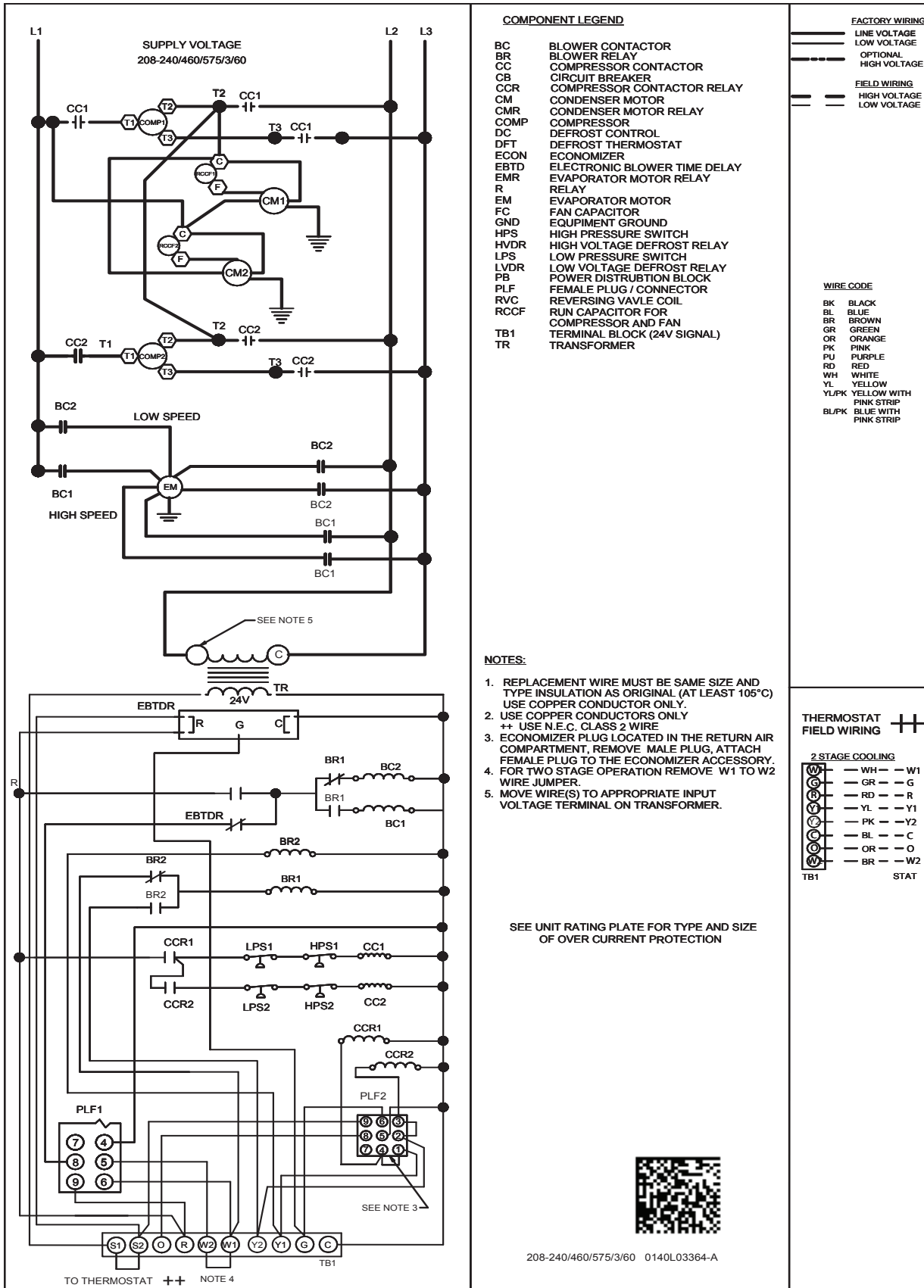

High Voltage: Disconnect all power before servicing or installing this unit. Multiple power sources may be present. Failure to do so may cause property damage, personal injury, or death.

WARNING

Wiring is subject to change. Always refer to the wiring diagram or the unit for the most up-to-date wiring.

DCC 10 - 12½ TONS (230V/460V/575V 2-SPEED, 3-PHASE BELT DRIVE)

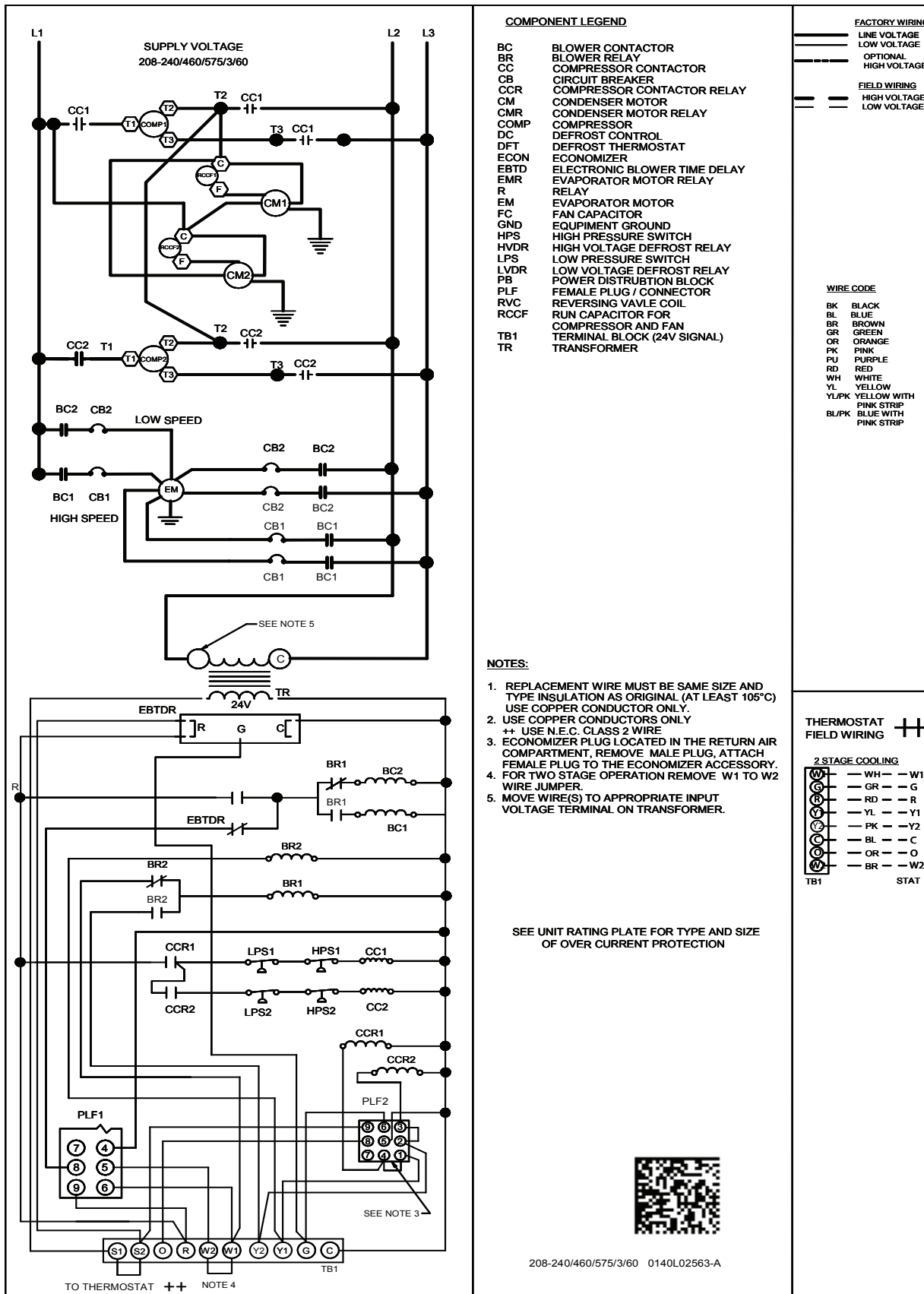

COMPONENT LEGEND

BC	BLOWER CONTACTOR
BR	BLOWER RELAY
CC	COMPRESSOR CONTACTOR
CB	CIRCUIT BREAKER
CCR	COMPRESSOR CONTACTOR RELAY
CM	CONDENSER MOTOR
CMR	CONDENSER MOTOR RELAY
COMP	COMPRESSOR
DC	DEFROST CONTROL
DFT	DEFROST THERMOSTAT
ECON	ECONOMIZER
EBTD	ELECTRONIC BLOWER TIME DELAY
EMR	EVAPORATOR MOTOR RELAY
R	RELAY
EM	EVAPORATOR MOTOR
FC	FAN CAPACITOR
GND	EQUIPMENT GROUND
HPS	HIGH PRESSURE SWITCH
HVDR	HIGH VOLTAGE DEFROST RELAY
LPS	LOW PRESSURE SWITCH
LVDR	LOW VOLTAGE DEFROST RELAY
PB	POWER DISTRIBUTION BLOCK
PLF	FEMALE PLUG / CONNECTOR
RVC	REVERSING VALVE COIL
RCCF	RUN CAPACITOR FOR COMPRESSOR AND FAN
TB1	TERMINAL BLOCK (24V SIGNAL)
TR	TRANSFORMER

FACTORY WIRING

—	LINE VOLTAGE
—	LOW VOLTAGE
---	OPTIONAL HIGH VOLTAGE
—	FIELD WIRING
—	HIGH VOLTAGE
—	LOW VOLTAGE

WIRE CODE

BK	BLACK
BL	BLUE
BR	BROWN
GR	GREEN
OR	ORANGE
PK	PINK
PU	PURPLE
RD	RED
WH	WHITE
YL	YELLOW
YL/PK	YELLOW WITH PINK STRIP
BL/PK	BLUE WITH PINK STRIP

NOTES:

1. REPLACEMENT WIRE MUST BE SAME SIZE AND TYPE INSULATION AS ORIGINAL. (AT LEAST 105°C) USE COPPER CONDUCTOR ONLY.
2. USE COPPER CONDUCTORS ONLY. ++ USE N.E.C. CLASS 2 WIRE
3. ECONOMIZER PLUG LOCATED IN THE RETURN AIR COMPARTMENT, REMOVE MALE PLUG, ATTACH FEMALE PLUG TO THE ECONOMIZER ACCESSORY.
4. FOR TWO STAGE OPERATION REMOVE W1 TO W2 WIRE JUMPER.
5. MOVE WIRE(S) TO APPROPRIATE INPUT VOLTAGE TERMINAL ON TRANSFORMER.

SEE UNIT RATING PLATE FOR TYPE AND SIZE OF OVER CURRENT PROTECTION

THERMOSTAT FIELD WIRING

++	STAT
----	------

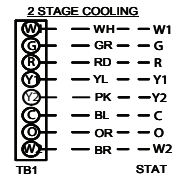

High Voltage: Disconnect all power before servicing or installing this unit. Multiple power sources may be present. Failure to do so may cause property damage, personal injury, or death.

WARNING

Wiring is subject to change. Always refer to the wiring diagram or the unit for the most up-to-date wiring.



208-240/460/575/3/60 0140L02563-A

ACCESSORIES

FILED-INSTALLED ITEM #	DESCRIPTION	FITS MODEL SIZES	FIELD- INSTALLED	FACTORY- INSTALLED
14CURB90150	14" Roof Curb	7½-12½ tons	√	
D25FD90150	25% Manual Fresh Air Damper	7½-12½ tons	√	
D25MFD90150	25% Motorized Fresh Air Damper	7½-12½ tons	√	
DBRD3672	Barometric Relief Damper (2 required)	7½-12½ tons	√	
DDNBBS90150	Burglar Bar Sleeves: includes Supply & Return	7½-12½ tons	√	
CDK120	Concentric Duct Kit	10 tons	√	
CDK150	Concentric Duct Kit	12½ tons	√	
CDK90102	Concentric Duct Kit	7½-8½ tons	√	
HailGD02D	Condenser Coil Hail Guard	7½-10 tons	√	
HailGD05D	Condenser Coil Hail Guard	12½ tons	√	
	Convenience Outlet: Powered	All Models		√
	Convenience Outlet: Non Powered	All Models		√
	Disconnect Switch (non-fused)	All Models		√
DDNECNJ90150	Downflow Economizer	7½-12½ tons	√	√
DDNSQRD9020	Downflow Square-to-Round Adapter 20" Round	7½ tons	√	
	Electric Heat Kits	All Models	√	√
HSKT090G ¹	High-Static Kit (230/460v)	7½ tons	√	
HSKT102 ¹	High-Static Kit (230/460v)	8½ tons	√	
HSKT090G-7 ¹	High-Static Kit (575v)	7½ tons	√	
HSKT102-7 ¹	High-Static Kit (575v)	8½ tons	√	
HSKT120 ¹	High-Static Kit (230/460v)	10 tons	√	
HSKT120-7 ¹	High-Static Kit (575v)	10 tons	√	
HSKT150 ¹	High-Static Kit (230/460v)	12½ tons	√	
HSKT150-7 ¹	High-Static Kit (575v)	12½ tons	√	
DHZECNJ90150	Horizontal Economizer	7½-12½ tons	√	
GHRC-1	Hurricane Restraint Clips	All Models	√	
LAKT03	Low-Ambient Kit	7½ - 12½ tons	√	√
DPE901502	Power Exhaust (208/230v)	7½-12½ tons	√	
DPE901504	Power Exhaust (460v)	7½-12½ tons	√	
DPE901507	Power Exhaust (575v)	7½-12½ tons	√	
IP90150	Roof Curb Insulated Panels	7½-12½ tons	√	
	Smoke Detector	All Models		√

¹ HSKT High-Static Kits are for use with standard single-speed belt-drive units only.

NOTES