

HEAT CONTROLLER

**INSTALLATION, OPERATION
& MAINTENANCE MANUAL**

**InverterFlex[®] Series
Ceiling Cassette**

VFH12/18/24CA

ATTENTION:



**Check for updates at
www.heatcontroller.com**

TABLE OF CONTENTS

Warnings and Cautions	1
Parts Identification	2
Installation Instructions	2
Service and Maintenance Clearances	3
Location Selection	3
Mounting the Ceiling Cassette	5
Line Set Installation	6
Condensate Drain Connection	7
Electrical Wiring	10
Wired Wall Thermostat Installation	12
Cassette Panel Installation	12
Care and Cleaning	16
Initial Start-up Checks	17
Troubleshooting	18
Error Codes	20





- Read the follow SAFETY PRECAUTIONS carefully before installation.
- Electrical work must be performed by a licensed electrician.
- Incorrect installation due to ignoring the instruction will cause harm or damage.

■ **The seriousness is classified by the following indications.**

 WARNING!	This symbol indicates the possibility of death or serious injury.
 CAUTION!	This symbol indicates the possibility of injury or damage to property.

The items to be followed are classified by the symbols:

	This symbol denotes item that is PROHIBITED from doing.
---	---

 WARNING!	
1) Do not install without an authorized servicer/installer.	
2) Install according to this installation instruction. If installation is defective, it can cause water leakage, or electric shock/fire.	
3) Use the supplied accessories and specified parts for installation.	
4) Install the indoor unit in a location strong enough to hold the unit's weight.	
5) For electrical work, follow local and national electric codes and these installation instructions. An independent circuit and single outlet must be used. If electrical circuit capacity is not enough or defects are found in electrical work, it may cause electrical shock or fire.	
6) Use the specified cable and connect tightly. Clamp the cable so that no external force will stress the connections. Loose wiring may overheat at the connection points and create a possible fire hazard.	
7) Wiring routing must be properly arranged so that control board cover is fixed properly. If control board cover is not fixed perfectly, it will cause overheating at connection point of terminal, fire or electrical shock.	
8) When charging the unit, take care not to let air/substances other than the specified refrigerant go into refrigeration circuit. Otherwise it will cause lower capacity, abnormal high pressure in the refrigeration circuit, explosion and injury.	
 CAUTION!	
1) This equipment must be grounded it may cause electrical shock if grounding work doesn't comply with local/national electric codes.	
2) Do not install the unit in place where leakage of flammable gas may occur. If gas leaks and accumulates near the unit, it may cause fire.	
3) Condensate must properly drain away from the unit as mentioned in installation instructions. If not done correctly, water may enter the room and damage personal property.	

Parts Identification:

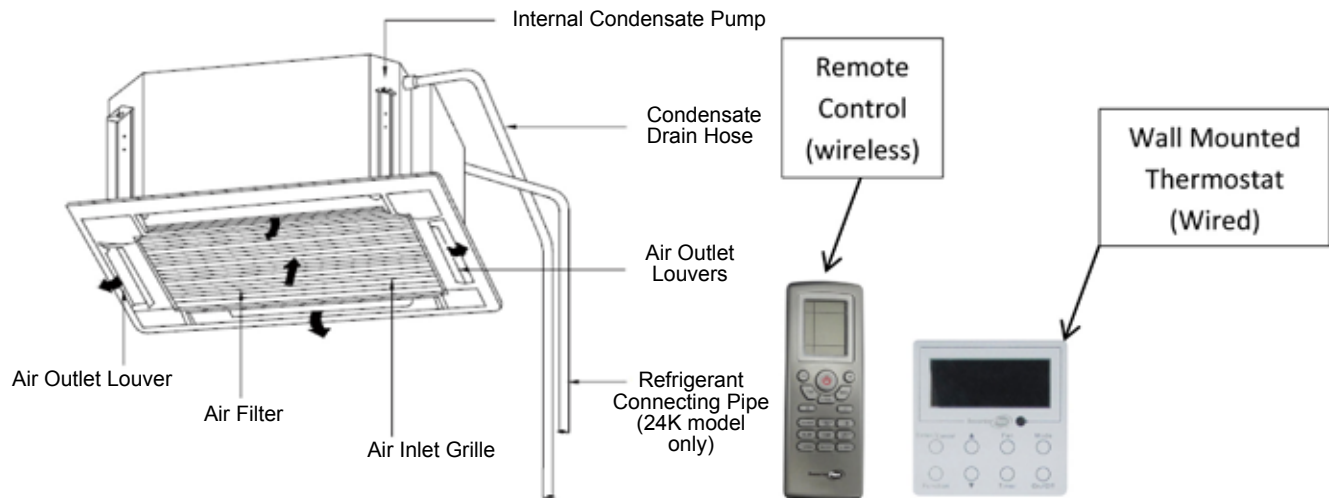

Note: The connecting pipe is only provided with the 24K – see Line Set Installation section of the manual for information.

Installation Instructions

ATTENTION:

- This product was designed using the metric measurement system; therefore all dimensions are designed to be adhered to using the metric measurement standards.
- Conversions from metric to United States customary units have been provided, as these products will be used and installed in United States trade and commerce. The US customary units are rounded to nearest tenths provided as a convenience for approximating only.
- Due to on-going product improvements, specifications and dimensions are subject to change and correction without notice or incurring obligations.
- Determining the application and serviceability for use of any product is the responsibility of the installer.
- The installer is responsible for verifying dimensional data on the actual product prior to beginning any installation preparations.
- All local and national building codes should be followed regarding installation and plumbing.
- For electrical wiring, all local and national electric codes should be followed.

Service and Maintenance Clearances:

Review the job site to ensure the area the unit is to be installed in will meet the required clearances.

ATTENTION: Clearances should always be maintained for proper performance, maintenance and service.

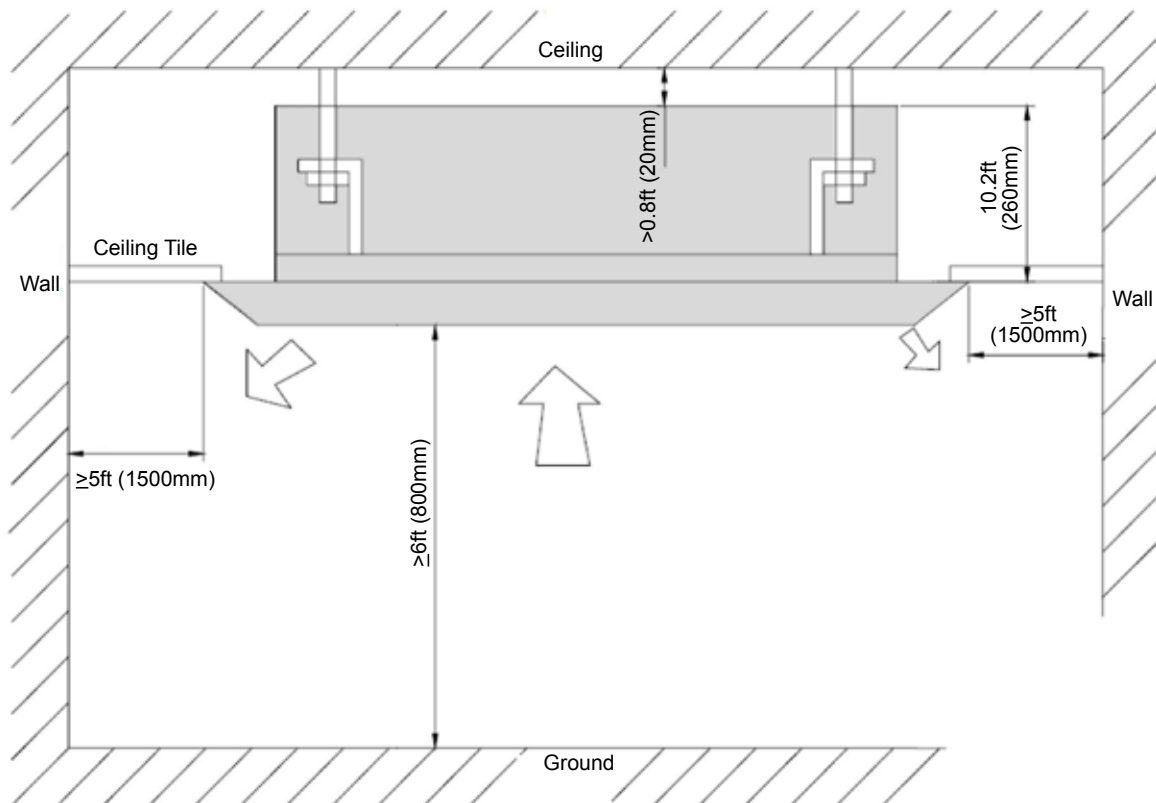

Location Selection

After ensuring clearances can be provided for, take into consideration the following regarding the installation location:

1. Ensure that there will be no obstacles blocking the airflow.
2. Select an installation location that is central to the area being conditioned.
3. Do not install near doorways or sources of heat/steam.
4. Make sure that condensation drainage can be conveniently routed away from the unit to a proper drainage location.
5. Choose a location that places the indoor unit as close to the outdoor unit as possible and/or within the guidelines for the maximum line set lengths and vertical lift. Do not exceed allowable refrigerant line lengths.
6. Unit must be installed in a location that can withstand at least four times the unit's weight (Check specifications for unit weight).
7. Do not install where the unit could be exposed to flammable gasses.
8. Unit must be able to sit level in the location selected.

9. Installation is designed for new or existing ceilings. However, anchoring/mounting to wood, steel, and concrete must follow all local/national building codes.
10. Mounting hardware for suspension in ceiling must be acquired locally. M10 or 3/8" diameter threaded rods and nuts are the recommended to ensure a proper fit with the mounting flanges of the unit.

Location Considerations:

The location must take into consideration the size of the indoor unit, ceiling opening, and where the threaded rods must be located to suspend the unit:

Model Capacity	Ceiling Opening Dimensions	Unit Dimensions	Threaded Rod Dimensions
	A x A in(mm)	B x B in(mm)	C1 x C2 in(mm)
12/18K	25.6(650) x 25.6(650)	22.4(570) x 22.4 (570)	15.8(400) x 23.8(604)
24K	35.0(890) x 35.0(890)	33.1(840) x 33.1(840)	26.8(680) x 30.7(780)

12/18K Model Dimensions:

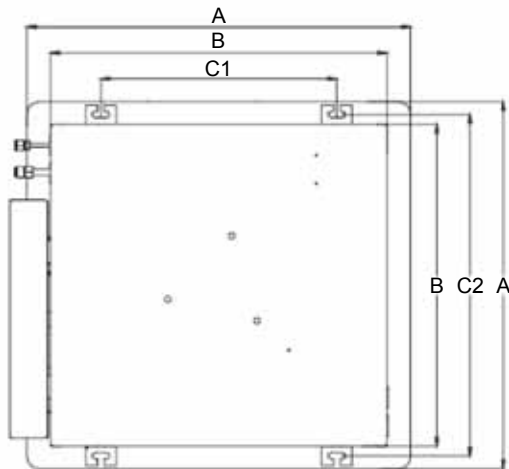

24K Model Dimensions:

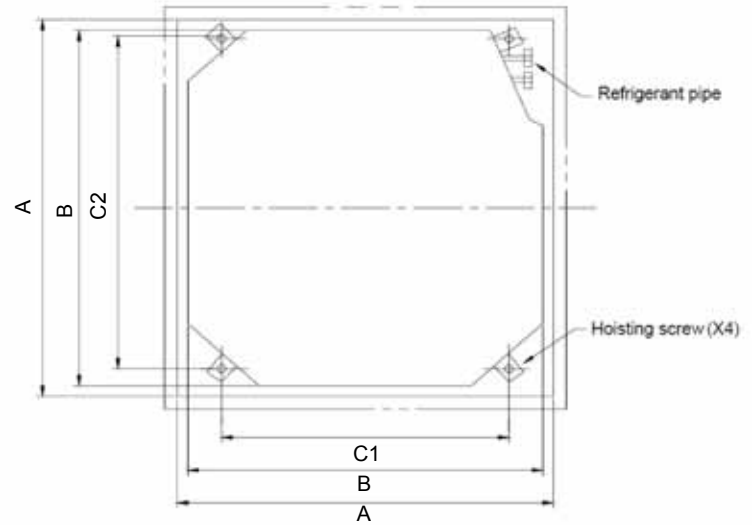

Additional considerations:

- Allow at least 6.3in (160mm) clearance from the top of the installation flange of the unit and the top of the ceiling cassette panel.
- The drop ceiling tile should overlap the edge of the ceiling cassette panel by at least 0.8in (20mm).

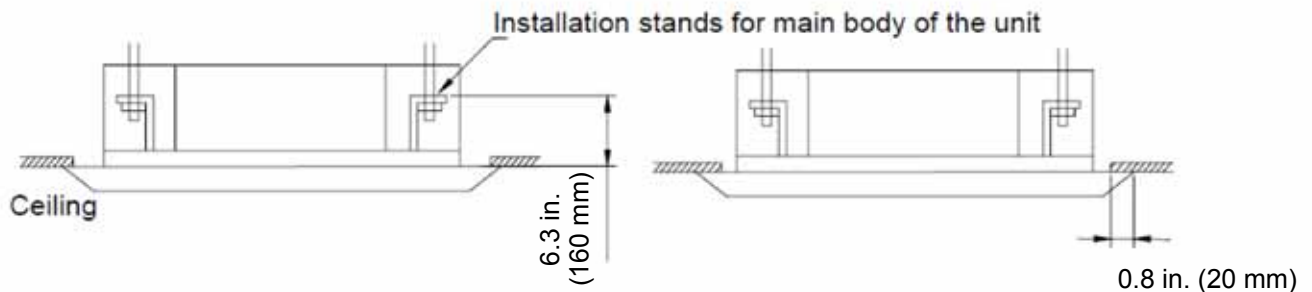

Mounting the Ceiling Cassette

If needed, a cardboard template is included with each unit to act as an installation guide to ensure that the ceiling tiles are cut to the proper size and threaded rods are placed in the right locations to suspend the unit.

ATTENTION: Before discarding the carton and/or packaging materials, locate the installation template:

The 12/18K template is tucked around the top of the unit and is visible.

The 24K template is tucked inside the lid of the carton - pull out this cardboard insert from the lid, as this is the template. Note: It may not be visible; as the template information is printed on the opposite side.

If using the cardboard template:

1. Center it onto the ceiling in the location where the ceiling cassette is intended to be mounted. Mark the locations for the threaded rods.
2. Install or anchor threaded rods in these locations – The threaded rods should be properly attached to the structure per any local or national building codes before suspending the unit.
3. Mark and make the opening in the ceiling for the unit.

Note: Depending on whether the ceiling is new or existing, the template can be attached to the indoor unit using the screws that contain a washer and lock washer for mounting the panel onto the unit.

Once the template is attached to the unit, the unit can be suspended or set into position, while the template is used to make the proper cuts into the ceiling tile and/or location markings for the threaded rods.

Once the threaded rods are installed and the opening is made, the ceiling cassette can begin to be suspended.

1. Start by placing a nut and washer onto the end of one of the threaded rods.
2. Then place the end of the same threaded rod through the installation flange of the unit.
3. Quickly place another washer followed by a nut onto the end of the threaded rod below the installation flange of the unit and hand tighten the bottom nut.
4. Repeat for all four threaded rods.
5. Now that the unit is suspended at all four points, tighten all the nuts above and below the flange to secure the unit.

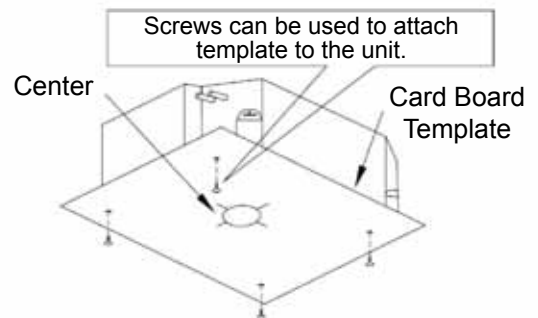

ATTENTION: Be sure that the unit is level and that all clearances are maintained.

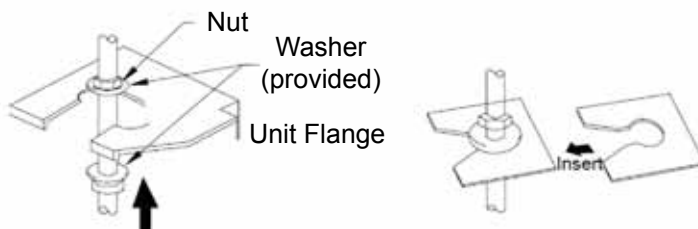

Line Set Installation

ATTENTION: Refer to the Outdoor unit's installation manual for all line set sizes and charging information.

Create Opening for Refrigerant and Condensate lines

1. Determine hole position according the unit's required clearances and which direction the lines will be routed from your unit.
2. Drill a 2.5" (65mm) hole angled downward (approx. 45°) toward the outdoors, if the line sets are being routed through a side wall.

WARNING: Ensure that neither studs nor plumbing are located directly behind the proposed opening location.

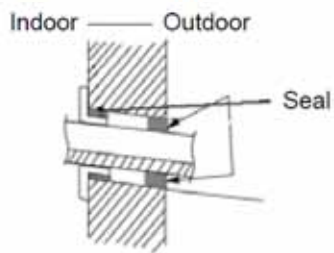

3. Always use a conduit to route the piping through the hole in the wall.
4. Properly seal the hole after routing the pipes through to prevent debris, insects, or small animals from entering.

Line Set Connection

When connecting the line set to the unit, use two wrenches – one to hold the flare connection on the unit and the other to attach and tighten the flare nut of the line set.

Attention: The 24K indoor unit comes with a connecting pipe to help provide some flexibility between the rigid connections (unit connection and the line set). This helps prevent the line from being kinked and allows for a proper bend radius. The connecting pipe has a flare connection to attach to the unit's refrigerant connector and a straight piece of copper on the other end, which would need to be flared and brazed in order to connect to the end of the line set from the outdoor section.



Notes:

1. Do not over tighten or torque the connections.
2. Lubricating the connection with oil is recommended.

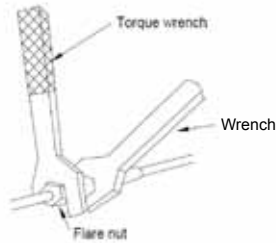

Once the connections have been made, locate the (2) pieces of pipe insulation provided with your unit to insulate the union between the line set and unit connections:

1. Remove the adhesive backing and wrap the smaller diameter pipe insulation over the liquid connection.
2. Next remove the adhesive backing from the larger diameter pipe insulation over the gas connection.
3. Using the roll of tape provided with the unit, wrap each connection's insulation.

Condensate Drain Connection

To create a flexible connection between the rigid drain outlet of the unit and the rigid drain pipe, a flexible drain hose adapter with hose clamp is provided (see figure below, left).

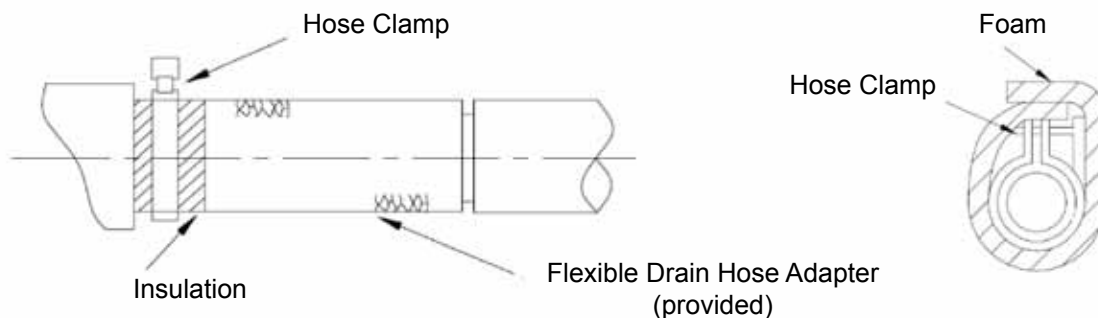

1. Slide the clamped end of the drain adapter onto the drain outlet on the unit.
Note: Loosening the hose clamp may be required to slide over the drain outlet.
2. Next tighten the hose clamp to ensure that no condensate will leak at the connection point.
3. After the connection has been made, locate the piece of foam with an adhesive backing provided with the unit.
4. Remove the adhesive backing and wrap the sticky side around the hose clamp at the connection point. (See figure above, right)
5. Additional drain pipe or hose can be provided in the field, purchased locally to route condensate to a suitable drainage location.
6. The condensate hose connection is a flexible 25mm O.D. that can slide over a rigid connecting drain pipe and/or be inserted into a rigid connecting drain pipe.

Notes:

- Appropriate adhesives and/or hose clamps should be used to prevent condensate leakage.
- The drain connection from the adapter to the drain pipe should be insulated.
- Follow all local and national building codes related to plumbing and drainage.

7. Ensure that there is no slack or sagging in the drain line from the indoor unit's condensate outlet on ward.

- Provide support for the drainage pipes if needed every 3-5ft(1-1.5m)
- Horizontal drainage piping shall be installed in uniform alignment at uniform slopes.
- Ensure a minimum 1/4" pitch per foot or 1m pitch slope over 100m length.

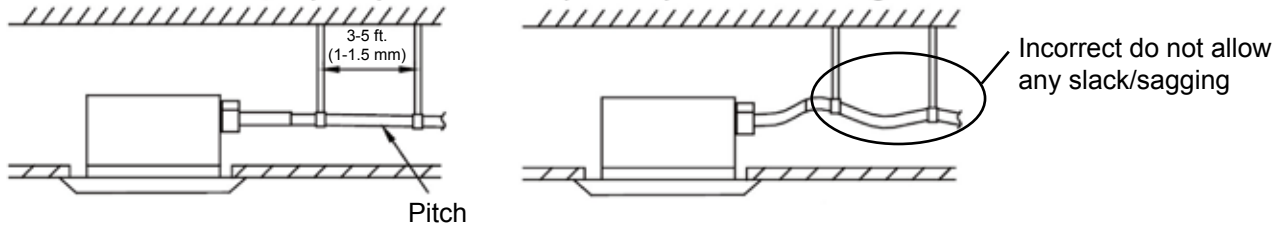

8. If a vertical rise is needed in the drain pipe, it should be made within 11.8in(300mm) of the indoor unit's drain outlet and not exceed 11in(280mm) in height.

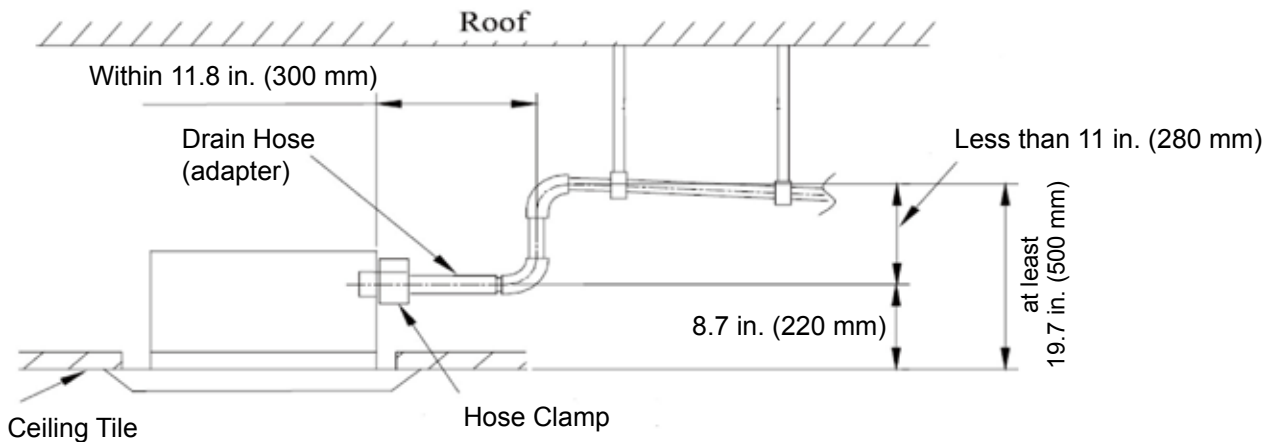

9. Any upward slopes in the drain adapter hose should not be made higher than 3in(75mm) than the unit's drain connection outlet.

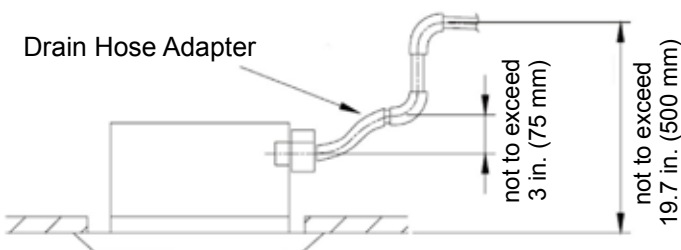

10. Condensate drain lines can be daisy chained together for several units, providing a downward slope over the entire run of 1/4" pitch per foot minimum (1:100 metric pipe gradient = 1m slope over 100 m of length)

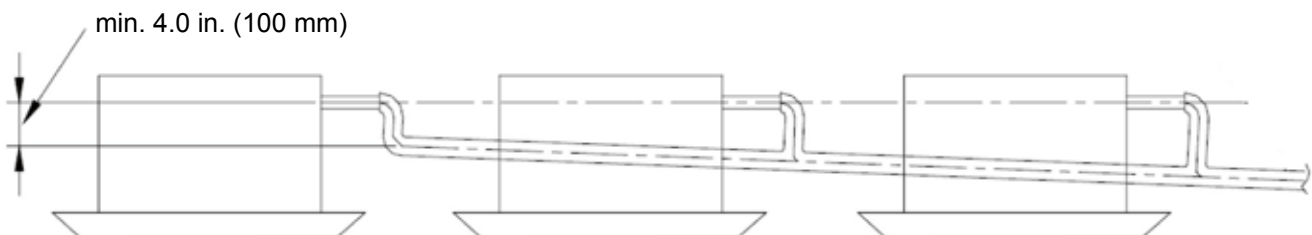

11. After all condensate piping is installed, ensure there are no leaks and that condensate will drain freely.
12. Test by slowly pour approximately 20oz (600ml) of water into the unit through the drain access location of the indoor unit. The square perforation in the foam of the housing is the knockout to access the condensate drain pan inside the unit.

Notes:

- The knockout is under the drain outlet on the 24K models as shown below.
- The knockout on the 12/18K model is on the opposite side of the unit from the drain outlet.
- A drain hole with plug is provided to drain condensate from the internal pan before repair or replacement.

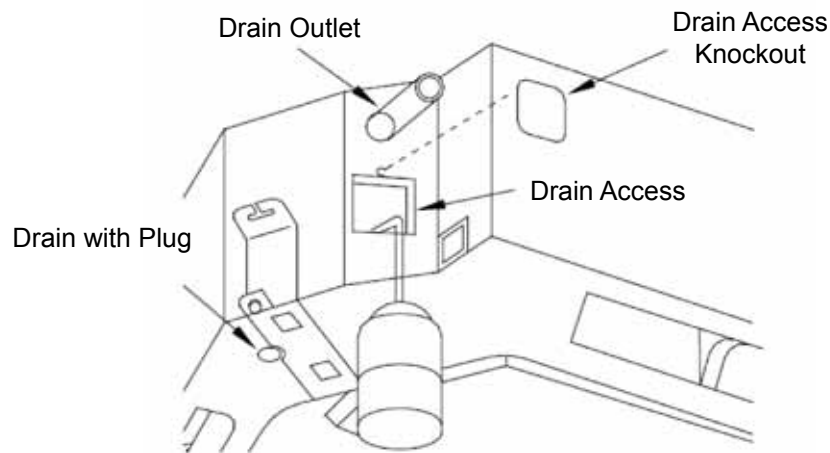

Electrical Wiring

WARNING: Wiring must conform to all local and national electric codes and be completed by an authorized installer.

ATTENTION: Below are representative wiring diagrams for reference only. Always refer to the wiring diagram on the actual unit, as information is subject to change due to on-going product improvements.

12/18K Wiring Diagram:

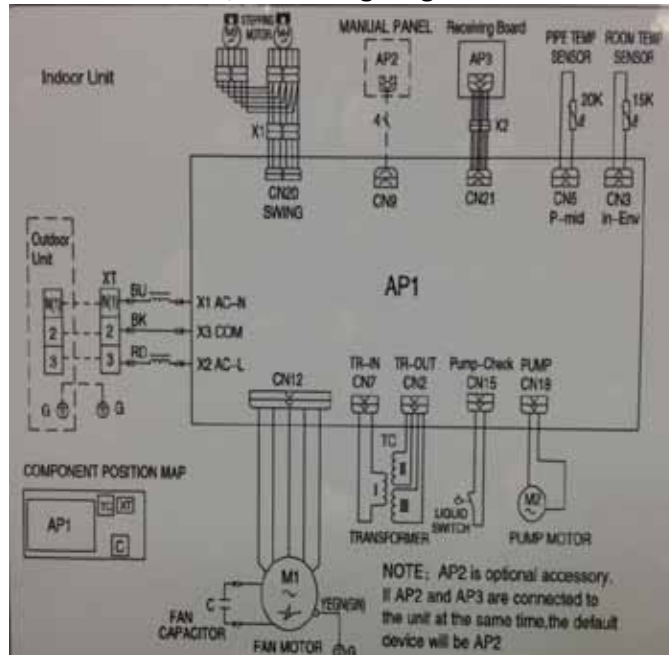

24K Wiring Diagram:

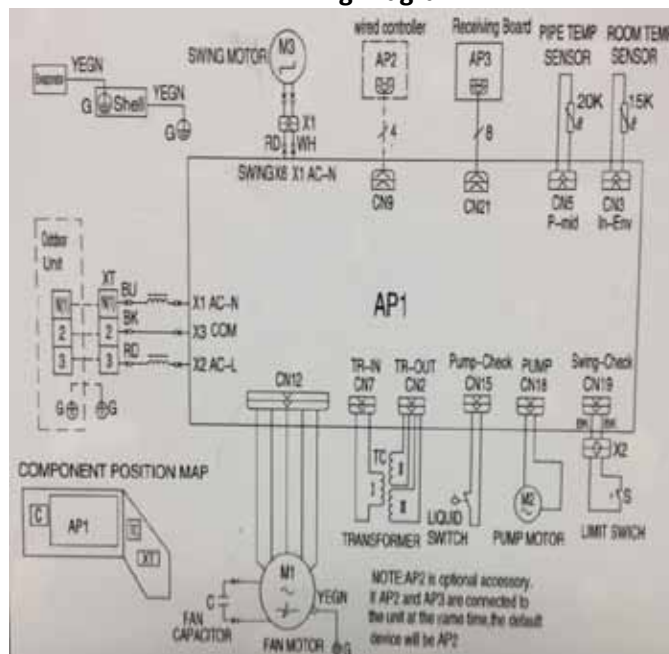

1. Heat Controller recommends using 600V THHN 14AWG/4 conductor unshielded stranded copper cable; however local and national codes for wire should always be followed based on your specific application.
2. The indoor unit's terminal strip is located underneath the electrical box cover panel.
3. Loosen the screws to remove the cover.
4. Pull the conductor through the rubber grommet of the electric box.
5. Connect each conductor from the outdoor to the appropriate terminal of the indoor unit based on the labels of each terminal.
6. Be certain that none of the connections are crossed and the wires are routed to properly match the outdoor unit's connections - wire color and location to and from each terminal must be identical between the indoor and outdoor terminal strips.
7. Ensure proper grounding.
8. Use cable clamp to secure the cable and provide a strain relief.
9. Wrap any loose cables not connected with terminals with electrical tape, so that they will not touch any electrical components.
10. Foam can be wrapped around the cable insulation to prevent any condensate.
11. After connections are securely made, replace the cover panel to the electrical box and screw it on tightly.

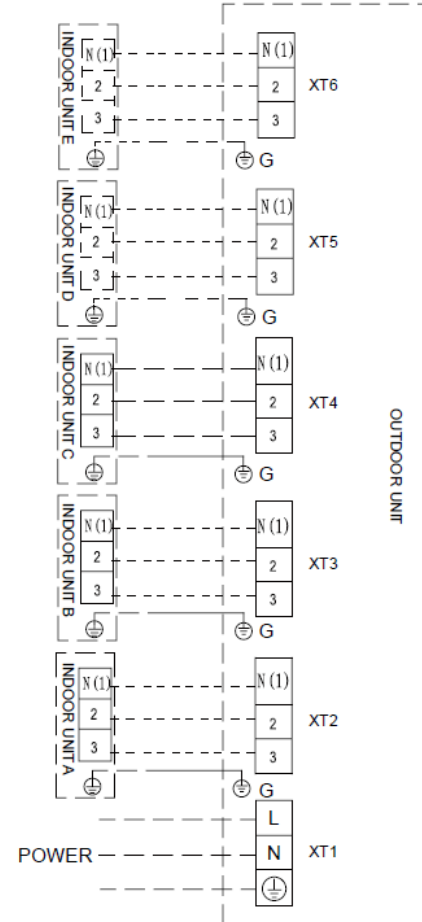

ATTENTION: When more than one indoor unit is installed, the dip switches on the outdoor unit's control board can be set to determine which indoor unit is considered the master, while the others are considered slave units. This helps to dictate which unit controls the system for better operation.

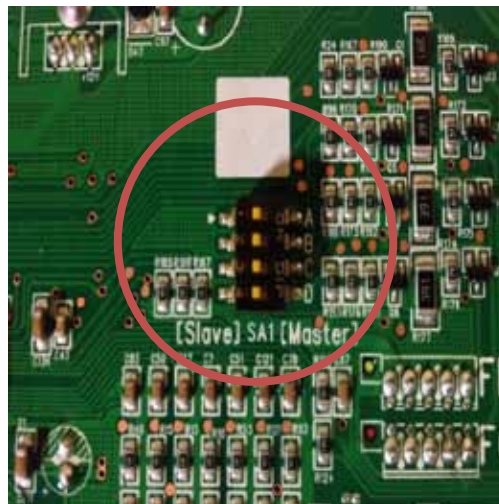

Note: Appearance of the board may vary, but similar dipswitches can be found on each outdoor board.

Wired Wall Thermostat Installation:

The ceiling cassette comes with an optional wall mounted wired thermostat.

ATTENTION:

- Use of the wall mounted thermostat will disable both the unit's control panel and the wireless remote. Alternatively, if the wall mounted thermostat is disconnected; both the unit's control panel and wireless remote can be used to operate the unit.
 - Each ceiling cassette must use an independent wireless remote or wall mounted wired thermostat.
 - The wired thermostats cannot be daisy chained together nor can one wireless remote control be programmed to operate all of the ceiling cassettes installed on a system.
 - If the wired thermostat is plugged in, the control panel of the unit will
1. Installation of the optional wired thermostat requires a connection to be made between it and the indoor unit's control board.
 2. Pass one end of the thermostat cable through the rubber gasket on the rear of the wall mounted thermostat and connect the connector to the board.
 3. Run the opposite end of the thermostat wire through the rubber gasket of the indoor unit's electrical control box.
 4. Remove the indoor unit's electrical box cover and connect the thermostat wire's connector to the connector labeled CN9 on the board.
 5. Re-install the electrical box cover and mount the thermostat to the wall location, if not already done.
 6. Any additional slack in the thermostat wire can be coiled up and bound with the provided wire ties.

NOTE: Refer to the owner's manual for instructions regarding the operation of the wired thermostat.

Cassette Panel Installation:

12/18K Cassette Panel Installation:

ATTENTION: The 12K/18K panel should be aligned so that its control panel is located on the same side as the indoor unit's electrical box.

1. The screw holes for the 12K/18K unit cannot be accessed without removing the air inlet grille that houses the filter.
2. To remove it, unscrew the (2) small shipping screws on the tabs of the air inlet grille, then push the tabs in to open the inlet grille.
3. The inlet grille can then be removed from the panel frame to expose the screw holes to attach it to the indoor unit.

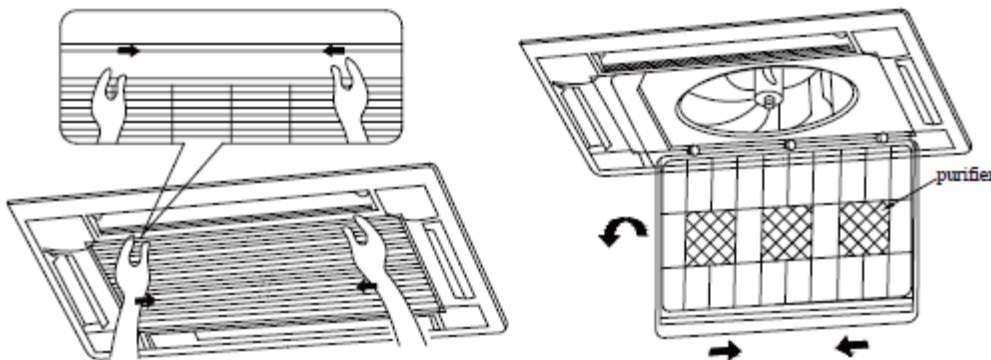

4. The screws provided with a washer and lock washer should be used to attach the panel frame to the indoor unit. **Attention:** Before screwing in the panel to the indoor unit, be certain that all of the connecting cables are pulled out for access later.

5. As the panel is being screwed in, ensure that it remains level on all sides.
6. The insulation material of the ceiling cassette panel will compress to create a tight seal.
7. Once installed, the inlet grille can be re-attached to the frame. The shipping screws on the tabs do not need to be re-installed.

24K Cassette Panel Installation:

ATTENTION:

- Before carrying out the panel installation process, please refer to the Electrical Panel Connections section of the manual. The 24K requires a pin connector to be connected to CN21 on the indoor unit's control board under the control panel cover. This step is easiest if done before the 24K panel is installed.
 - The 24K panel should be aligned such that the louver motor is on the same corner as the indoor unit's refrigerant connections.
1. 24K panel should be suspended by the metal clips onto the indoor unit's hooks during installation.
 2. Two of the hooks for the metal clips are on the exterior edge of the unit; the other two can only be accessed when the air inlet grille is removed, by reaching inward.

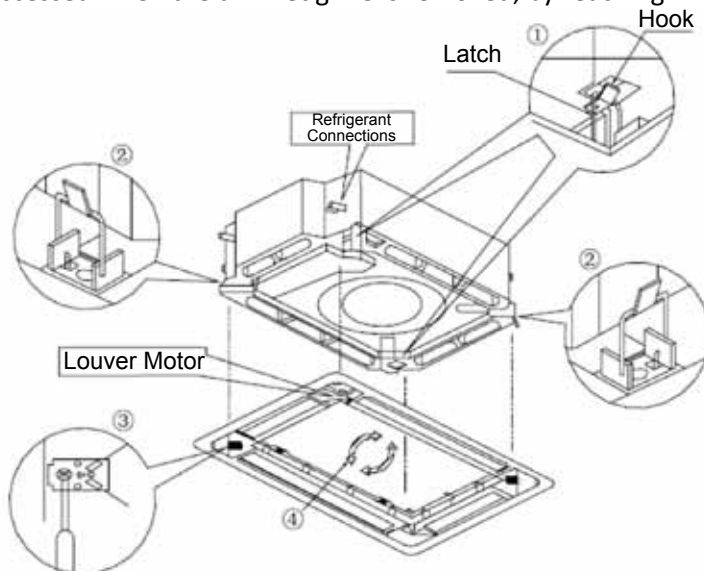
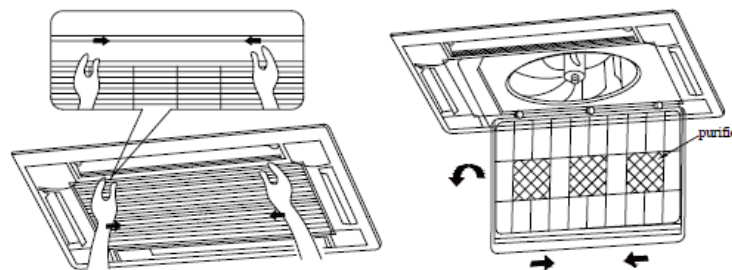

Photo of clip attached to hook



3. To remove the air inlet grille, unscrew the (2) small shipping screws on the tabs of the air inlet grille, then push the tabs in to open the inlet grille.
4. The inlet grille can then be removed from the panel frame to access the metal clips and attach to the inside of the unit.



5. Once all Four clips are attached the hooks on the unit, the panel needs to be tightened. To access the screws for tightening down, each corner cover must be removed.

6. To remove the corner cover panels, simply reach inside the circular indentation and pull outward toward the corner in the direction of the arrow shown below.
 - The cover is attached with magnets, so no heavy force is required to remove the corner covers.
 - Each corner cover is secured with a cable, so that it will not fall once it is removed.



7. With the cover removed from each corner, a leveling screw will be exposed. Simply tighten the screw to raise the panel on each corner. **Note:** There is a small arrow stamped into the bracket to signify which screw to tighten.

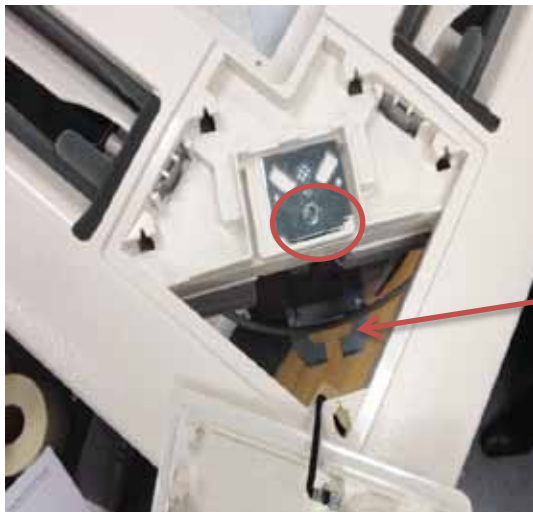

ATTENTION: The corner cover panels can be removed to also provide access to the threaded rod.

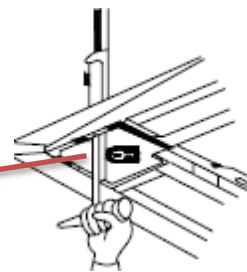

8. As the panel is being screwed in, ensure that it remains level on all sides.
9. The insulation material of the ceiling cassette panel will compress to create a tight seal.
10. Replace the corner cover panels on all four corners.

WARNING: If a gap exists between the ceiling tiles and the ceiling cassette panel, condensate may leak.

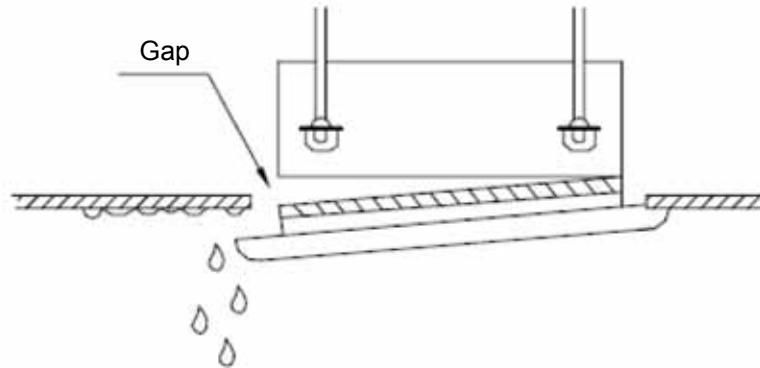

Panel Electrical Connections

1. Once the panel is installed, the connections can be made between the panel and the indoor unit.
2. There are two cables with connectors on each end.
3. The connectors are different, so they can only connect one way and cannot be interchanged.
4. Be sure these connections are securely made to ensure power is sent from the indoor unit to the panel's louver motors and controls.

ATTENTION:

- The 12/18K model has (2) connections to be made between the panel and the indoor unit.
- The 24K model has (3) connections to be made. Two of these connections are made between the indoor unit and the panel (red and white connectors) and the third pin connector will be connected to CN21 on the indoor unit's control board underneath the control panel cover.

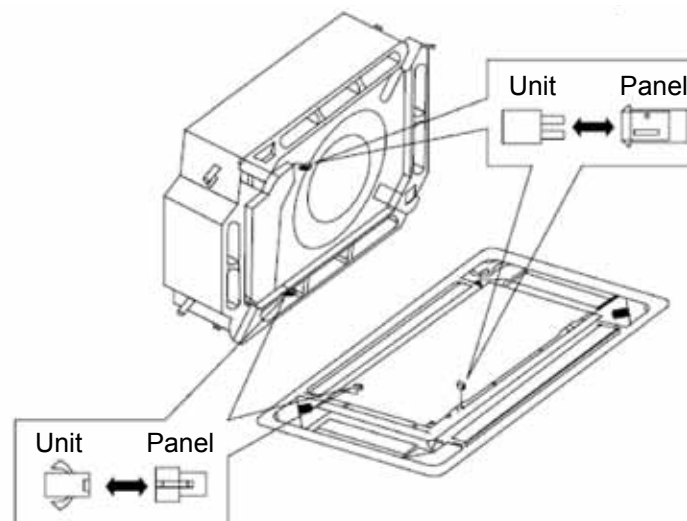

Care and Cleaning

WARNING: Electrical Shock Risk - Always turn off the main power supply to the unit before performing any cleaning or maintenance!

CAUTION: Do not use extremely hot water or harsh chemicals to clean, as they may deform or deteriorate the surface of the unit, filter or grille.

1. When the unit will not be used for an extended period of time, turn off the main power supply to the unit.
2. The unit can be dusted or cleaned with a damp wash cloth, ensuring no moisture gets into the electrical control panel.
3. If needed, a mild detergent can be used. Do not use any hard abrasives or flammable cleaning products that can deteriorate the surface.

Cleaning the Air Filter

1. The air filter should be cleaned to remove accumulated dust. Dust that builds up and clogs the air filter, will decrease air flow and the unit's performance.
2. Clean the filter at least every six months or more frequently if dust builds up.
WARNING: Before accessing the filter, be sure the power is turned off.
3. To access the filter, push the two tabs inward to release the inner inlet grille.
Note: There are (2) small shipping screws that may need to be removed in order to push the tabs inward. These screws should have been removed to install the panel, however if they were not or they were re-installed they will need to be removed.

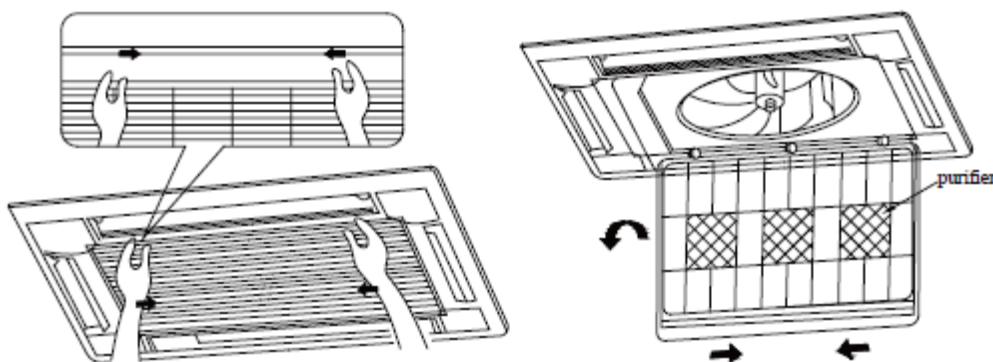

4. Once the inlet grille has been released, the filter can be removed for cleaning.
5. Vacuum the dust from the filter using a vacuum hose attachment with brush. If needed, the filter can be washed in lukewarm water and a mild detergent. Allow the filter to air dry before proceeding to the next step.
6. Once the filter is clean and dry, reinstall it into the inlet grille.
7. Push the inlet grille back up toward the frame of the panel.
8. Push the tabs back outward to lock the inlet grille in place and prevent it from falling.

Cleaning the Air Inlet Grille

1. The air inlet grille should be cleaned in addition to the air filter when it becomes dusty.
2. Using the same process above, open the air inlet grille and remove the filter.
3. The air inlet grille can be removed completely from the panel.

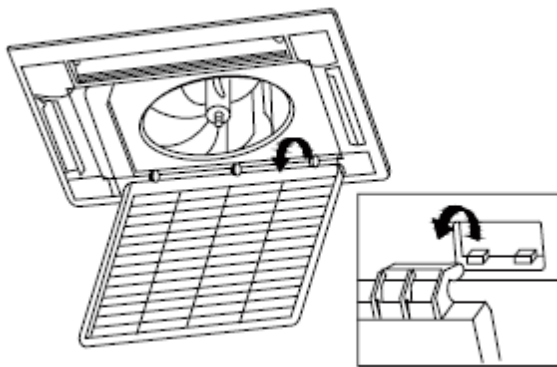

4. Vacuum the dust from the grille using a vacuum hose attachment with brush. If needed, the grille can be washed in lukewarm water and a mild detergent. Towel dry the inlet grille before proceeding to the next step.
5. Reinstall the filter into the air inlet grille.
6. Push the inlet grille back up toward the frame of the panel.
7. Push the tabs back outward to lock the inlet grille in place and prevent it from falling.

Cleaning the Air Outlet Louvers

1. The air outlet louvers can be dusted to remove any dust build-up.
2. Vacuum the dust from the louver using a vacuum hose attachment with brush.

Initial Start-up and Test Run

1. When the ambient temperature is too low to run the unit in cooling mode to check the system, the unit can be placed into manual operation.
2. To test the unit's operation, ensure that the wired wall thermostat is disconnected in order for the control panel to become operational. Note: If the wall mounted thermostat is not being used in the application, disregard this step.
 - a. Turn the power off by the disconnect switch, allow the capacitors of the outdoor unit to discharge.
 - b. Disconnect the wall mounted thermostat from CN9 on the control board.
 - c. Turn the power back on at the disconnect switch.
3. With the power on, using the unit's control panel, press the test button to force the unit into cooling mode.
4. In test mode, verify the system is operating as expected. If not, make the proper adjustments and re-test.
5. After the system has been confirmed to run properly, the wired wall thermostat can be re-connected with the power off if being used in the application.

Troubleshooting

WARNING:

- All service and maintenance should be carried out by an authorized servicer. Do not try to service the unit yourself.
- If you notice a malfunction has occurred (such as abnormal noises, smoke or burning smells), turn off the power to the unit immediately and contact an authorized servicer.
- Always disconnect power before performing any service or maintenance.

Some issues can be resolved without any maintenance to the unit, check the chart below to see if there is a suggested solution to the problem before calling for service.

Problem	Cause	Solution
The unit will not operate at all.	Blown Fuse or tripped circuit breaker.	Check the fuse or circuit breaker. Replace the blown fuse or reset the circuit breaker.
	Power Failure	Wait until the power is restored to restart the unit. If you experience brown out conditions, contact an electrician or your local utility.
	Remote Control batteries are low	Replace the batteries. Be sure not to mix old and new batteries, as well as different brands/types.
	Signal from remote control is not being sent	Be sure that you are not using the remote control too far away from the indoor unit's control panel.
The unit runs and then stops immediately	Air inlets and/or outlets are blocked	Remove any obstacles from the air inlets/outlets
		Clean the air filter, louvers, and inlet grille.
Abnormal heating or cooling	Air inlets and/or outlets are blocked	Remove any obstacles from the air inlets/outlets
		Clean the air filter, louvers, and inlet grille.
	Improper temperature is set	Ensure that the proper mode and temperature is set on the unit. Try to adjust the set point temperature on the thermostat to a better operating temperature.
	Check the fan speed	Adjust the fan speed to see if that improves the conditions.
	Improper louver adjustment	Try to adjust the louver position to ensure it is open enough.
Be sure that there are no other sources of heat/steam in the area being cooled	Remove or turn off other appliances producing heat or steam.	

	Conditioned air might be escaping	Ensure that any doors or windows in the area being heated/cooled are closed.
Unit will not run when turned on	There is a time delay built into the unit to protect the compressor	Wait a few minutes after turning on the unit for heating/cooling to begin.
	Improper temperature is set	Ensure that the proper mode and temperature is set on the unit. Try to adjust the set point temperature on the thermostat to a better operating temperature.
A mist is coming out of the outlet air louvers	This is a normal occurrence when in cooling mode	A fine mist might be seen coming from the air outlet louvers when the unit is being run in cooling mode and there is high humidity in the room. As the humidity is removed from the air, as a result of the room being cooled, the mist will go away.
Strange noises are coming from the unit	A click sound is heard once the unit begins to operate	This is a normal sound; it is the opening of the expansion valve.
	A hissing sound is heard continuously	This is a normal sound, usually when the unit is operating in cooling mode. It is simply the sound of the refrigerant flowing through the system.
	A hissing sound is heard when the unit starts up or just after it has stopped	This is a normal sound, it is coming from the condensate drainage pumping system or it is the sound of the refrigerant gas flowing in the system.
	A creaking noise is heard from the indoor unit	This is a normal sound, as the temperature changes in the room, the plastic cassette panel or other components expand and contract, creating a creaking sound.
Dust is blowing out of the louvers	Unit has been sitting for a long period of time with accumulated dust and/or the filter/grille/louvers need to be cleaned.	Properly clean dust from the unit as described in the Care and Cleaning section of the manual.
Strange Odor is coming from the unit	The air quality of the conditioned space is not good.	Unless the smell is a burning smell, which is abnormal and means service is required; all other smells generated are normally from the conditioned space. Odors, such as cigarette smoke, are simply sucked into the unit from the conditioned

		space and then discharged back into the conditioned space. Try to ventilate the space, clean, or remove the source of the odor.
	Odor occurs the first time the unit operates or after the unit has been unused for an extended period of time.	If the unit is being operated for the first time, after being installed, or it has not been run for an extended period of time, there might be a slight odor that will dissipate. A new unit may have a plastic smell coming from the filter material; this is normal and will go away over time. If the unit has not been used for an extended period of time, there might be a dusty odor that will dissipate as well. See care and cleaning instructions in the manual.
An Error Code is Displayed on the Control Panel	The unit has detected an error	Contact an authorized servicer.

Glossary of Error Codes and Their Meanings:

Error Item	Outdoor Unit 88 Display	Indicating LED Flashing Times			88 Display	Wired Controller Display	Error Type
		Running LED	Cooling LED	Heating LED			
High Pressure Protection	E1	Flash once	/	/	E1	E1	Outdoor
Shutdown for Whole Unit Anti-Freeze Protection	E2	Flash twice	/	/	E2	E2	System Error
Low Pressure Protection	E3	Flash 3 times	/	/	E3	E3	Outdoor
High Discharge Temp Protection	E4	Flash 4 times	/	/	E4	E4	Outdoor
Communication Error	E6	Flash 6 times	/	/	E6	E6	Outdoor & Indoor
Indoor Unit Water Full Error	E9	Flash 9 times	/	/	E9	E9	Indoor
Refrigerant Recovery Mode	Fo	Quick Flashing	Quick Flashing	/	Fo	Fo	Special Mode
Outdoor Ambient Temp Sensor Error	F3	/	Flash 3 times	/	F3	F3	Outdoor
Outdoor Mid-Coil Temp Sensor Error	F4	/	Flash 4 times	/	F4	F4	Outdoor
Outdoor Discharge Air Temp Sensor Error	F5	/	Flash 5 times	/	F5	F5	Outdoor

Oil Return for Cooling	F7	/	/	/	/	/	Special Mode
Forced Defrosting	H1	Quick Flashing	/	/	H1	H1	Special Mode
Oil Return for Heating or Defrosting	H1	/	/	Flash once	H1		Special Mode
Compressor Overheat Protection	H3	/	/	Flash 3 times	H3	H3	Drive Error
IPM Protection	H5	/	/	Flash 5 times	H5	H5	Drive Error
Motor Desynchronizing	H7	/	/	Flash 7 times	H7	H7	Drive Error
PFC Error	Hc	/	/	Flash 6 times	Hc	Hc	Drive Error
Startup Failure	Lc	/	/	Flash 11 times	Lc	Lc	Drive Error
DC Fan motor Error	LA	/	/	/	/	/	Outdoor
Phase Loss	Ld	Flash 3 times	Flash 3 times	Flash 3 times	Ld	Ld	Drive Error
Compressor Stalling	LE	Flash 3 times	Flash 3 times	Flash 3 times	LE	LE	Drive Error
Over-Speed	LF	Flash 3 times	Flash 3 times	Flash 3 times	LF	LF	Drive Error
IPM Reset	P0	Flash 3 times	Flash 3 times	Flash 3 times	P0	P0	Drive Error
Compressor Current Protection	P5	/	/	Flash 15 times	P5	P5	Drive Error
Communication Error between the Inverter Drive and the Main Controller	P6	Flash 16 times	/	/	P6	P6	Drive Error
Radiator Temp Sensor Error	P7	/	/	Flash 18 times	P7	P7	Drive Error
Radiator Overheat Protection	P8	/	/	Flash 19 times	P8	P8	Drive Error
AC Contactor Protection	P9	Flash 3 times	Flash 3 times	Flash 3 times	P9	P9	Drive Error
Current Sensor Error	Pc	/	/	Flash 12 times		U1	Drive Error
Sensor Connection Protection	Pd	Flash 3 times	Flash 3 times	Flash 3 times	Pd	Pd	Drive Error
Over Voltage Protection	PH	/	Flash 11 times	/	PH	PH	Drive Error

Low Voltage Protection	PL	/	/	Flash 21 times	PL	PL	Drive Error
Temp Drift Protection	PE	Flash 3 times	Flash 3 times	Flash 3 times	PE	PE	Drive Error
Drive Board Ambient Temp Sensor Error	PF	Flash 3 times	Flash 3 times	Flash 3 times	PF	PF	Drive Error
AC Current Protection	PA	Flash 5 times	/	/	E5	E5	Drive Error
Charging Circuit Error	PU	/	/	Flash 17 times	PU	PU	Drive Error
AC Input Voltage Anomaly	PP	Flash 3 times	Flash 3 times	Flash 3 times	PP	PP	Drive Error
Unit n communication error	See Table 16	Flash 6 times	/	/	E6	E6	Indoor
Unit n indoor pipe midway temperature sensor error	See Table 16	/	Flash twice	/	E2	E2	Indoor
Indoor Evaporator Temp Sensor Short/Open-Circuit	See Table 16	/	Flash twice	/	F2	F2	Indoor
(Air Valve) Unit n indoor unit pipe outlet temperature sensor error	See Table 16	/	Flash 22 times	/	b7	b7	Indoor
(Liquid Valve) Unit n indoor pipe inlet temperature sensor error	See Table 16	/	Flash 19 times	/	b5	b5	Indoor
Unit n mode conflict	See Table 16	/	Flash once	/	F1	F1	Indoor
Mode Conflict	See Table 16	Flash 7 times	/	/	E7	E7	Indoor

This page is left intentionally blank.

This page is left intentionally blank.

This page is left intentionally blank.

Due to ongoing product improvements, specifications and dimensions are subject to change and correction without notice or incurring obligations. Determining the application and suitability for use of any product is the responsibility of the installer. Additionally, the installer is responsible for verifying dimensional data on the actual product prior to beginning any installation preparations.

Incentive and rebate programs have precise requirements as to product performance and certification. All products meet applicable regulations in effect on date of manufacture; however, certifications are not necessarily granted for the life of a product.

Therefore, it is the responsibility of the applicant to determine whether a specific model qualifies for these incentive/rebate programs.

HEAT CONTROLLER

1900 Wellworth Ave., Jackson MI 49203 • Ph. 517-787-2100 • www.heatcontroller.com

A  Company