

# KFFEH Electric Heater Packages

## Installation Instructions

**NOTE:** Read the entire instruction manual before starting the installation.

### SAFETY CONSIDERATIONS

Installing and servicing of heating and air conditioning equipment can be hazardous due to system pressures and electrical components. Only trained personnel should install or service heating and air conditioning equipment.

Untrained personnel can perform basic maintenance functions such as cleaning coils, or cleaning and replacing filters. All other operations should be performed by trained personnel. When working on heating and air conditioning equipment, observe precautions in literature, on tags, and on labels attached to the unit.

Follow all safety codes. Wear safety glasses and work gloves. Have a fire extinguisher available.

Recognize safety information. This is the safety-alert symbol ⚠. When you see this symbol on the unit and in instructions or manuals, be alert to the potential for personal injury.

Understand the signal words DANGER, WARNING, and CAUTION. These words are used with the safety-alert symbol. DANGER identifies the most serious hazards which will result in severe personal injury or death. WARNING signifies hazards which could result in personal injury or death. CAUTION is used to identify unsafe practices, which may result in minor personal injury or product and property damage. NOTE is used to highlight suggestions which will result in enhanced installation, reliability, or operation.



**WARNING**

#### ELECTRICAL SHOCK HAZARD

Failure to follow this warning could result in personal injury or death. Before beginning any installation or modification, be sure the main electrical disconnect switch(es) is in the OFF position. There may be more than one power supply. Tag the disconnect switch(es) with a suitable warning label.

Table 1 – EH Heater Table

HEATER PART NO.	kW @ 240V	VOLTS/PH	STAGES (kW OPERATING)	INTERNAL CIRCUIT PROTECTION	FAN COIL SIZE USED WITH	HEATING CAP.* @ 230V
KFFEH8401N03	3	230/1	3	None	18†	9,400
KFFEH8501N05	5	230/1	5	None	18†	15,700
KFFEH8801N08	8	230/1	8	None	18†	25,100
KFFEH8901N10	10	230/1	10	None	18†	31,400
KFFEH0401N03	3	230/1	3	None	24	9,400
KFFEH0501N05	5	230/1	5	None	24–60	15,700
KFFEH0801N08	8	230/1	8	None	24–60	25,100
KFFEH0901N10	10	230/1	10	None	24–60	31,400
KFFEH3201F20	20	230/1	5, 20	Fuse‡	30–60	62,800
KFFEH8401C05	5	230/1	5	Circuit Breaker	18†	15,700
KFFEH8501C08	8	230/1	8	Circuit Breaker	18†	25,100
KFFEH8601C10	10	230/1	10	Circuit Breaker	18†	31,400
KFFEH2401C05	5	230/1	5	Circuit Breaker	24–60	15,700
KFFEH2501C08	8	230/1	8	Circuit Breaker	24–60	25,100
KFFEH2601C10	10	230/1	10	Circuit Breaker	24–60	31,400
KFFEH3301C20	20	230/1	5, 20	Circuit Breaker	30–60	62,800
KFFEH2901N09	9	230/1**	3, 9	None	36–60	28,200
KFFEH3001F15	15	230/1	5, 15	Fuse‡	24–60	47,100
KFFEH3101C15	15	230/1	5, 15	Circuit Breaker	24–60	47,100
<b>3 Phase Only</b>						
KFFEH1601315	15	230/3	5, 15	None	36–60	47,100
KFFEH2001318	18	230/3	6, 12, 18	None	42–60	56,500
<b>3 Phase, Factory Shipped (field convertible to single phase)</b>						
KFFEH3401F24	24	230/3	8, 16, 24	Fuse	48, 60	78,300
KFFEH3501F30	30	230/3	10, 20, 30	Fuse	48, 60	94,100

\*. Does not include heat from blower motor.  
†. Size 18 fan coil has a special 6-pin connector. Do not modify wiring.  
‡. Single point wiring kit required for these heaters.  
\*\*. Field convertible to 3 phase.

**Table 2 – Minimum CFM and Motor Speed Selection**

FAN COIL SIZES	HEATER kW									
	3	5	8	9	10	15	18	20	24	30
18	525	525	525	—	600*	—	—	—	—	—
24	700	700	700	700	700	775*	—	—	—	—
30	—	875	875	875	875	875	—	1060*	—	—
36	—	1050	970	970	970	920	—	1040	—	—
42	—	1225	1225	1225	1225	1225	1225	1225	—	—
48	—	1400	1400	1400	1400	1400	1400	1400	1400	1400
60	—	1750	1750	1750	1750	1750	1750	1750	1750	1750

\*. Indicates medium speed (blue). All other motor speeds at low tap.

**NOTE:** Use an accessory downflow base to maintain proper clearance on downflow installations.

This instruction describes the installation of Part No. KFFEH accessory heaters in FJ4 and PF4MNX fan coils.

## ! WARNING

**FIRE HAZARD**  
 Failure to follow this warning may cause personal injury, death, or property damage.  
 Flame resistant materials must be used for ductwork for fan coils with combustible clearance requirements.

Electric heaters require a minimum airflow. Minimum airflow and motor speed selection are listed in [Table 2](#). For FJ4DNX24-60 3-through 18 kW standard heaters, there are no combustible clearance requirements for the first 36 in. (914 mm) of ductwork. For FJ4DNXA18 and PF4MNXA18 with 8 kW and 10 kW heaters, a 1 in. (25 mm) combustible clearance is required for the first 12 in. (305 mm) of ductwork. For 20 kW through 30 kW heaters, a 1 in. (25 mm) combustible clearance is required for the first 36 in. (914 mm) of ductwork.

**Procedure 1 — Install Electric Heater Assembly**

**NOTE:** Ensure heater coils are not deformed or damaged during heater installation.

1. Make sure power to unit is off.
2. Remove blower access panel of fan coil unit.

## ! CAUTION

**ELECTRICAL OPERATION HAZARD**  
 Failure to follow this caution may result in equipment damage or improper operation.  
 Before installation of heater, the black and yellow pigtail leads must be removed from the fan coil PCB or wire harness to prevent possible damage to the product. Electrical power will be provided to the board through the heater circuit plug.

3. Disconnect 2 power wires (black and yellow pigtail leads) from PCB or wire harness (if applicable) and discard. Wires may be part of a plug assembly or attached to terminals L1 and L2. Remove cooling control plate from fan coil (if equipped). For 18-, 24-, and 30-kW heaters, remove adapter plate ([Fig. 1](#)).

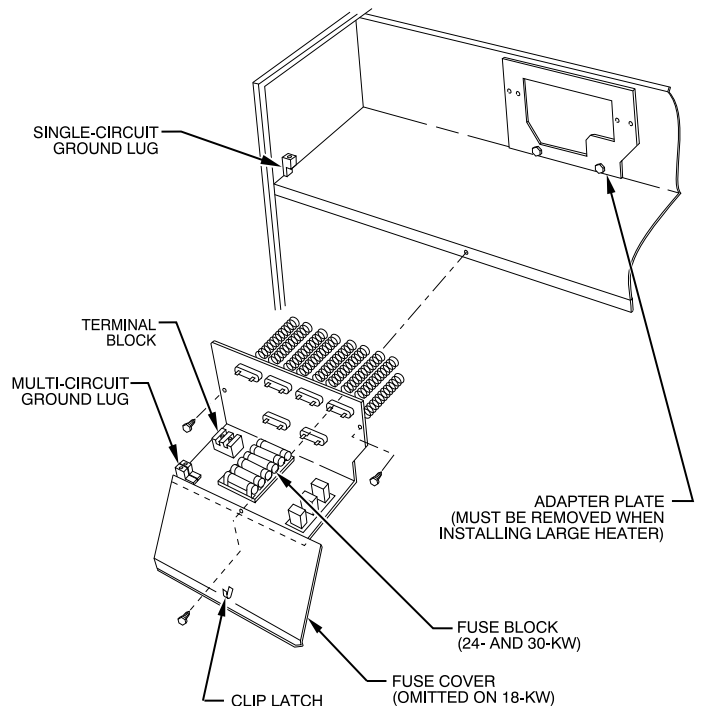

**Fig. 1 – Installation of 18-, 24-, and 30-kW Model Heaters**

4. Insert heater assembly into front of fan coil so that element rods engage holes in rear heat shield.
5. Attach heater control plate to fan coil using 2 screws provided. For 18-, 24-, and 30-kW heater models, attach front of heater to fan deck using third screw ([Fig. 1](#)).

**Procedure 2 — Attach Fuse Box or Circuit Breaker Box**

1. For 15- and 20-kW fused models:  
 After installing heater assembly, attach fuse assembly to side of fan coil unit by inserting fuse box tab between insulation and to left side of unit and fan deck. Mount front of assembly to side flange with 2 screws provided. On fan coil units size 42 and larger, remove wire tie that shortens wire length between heater and fuses. Fuse cover is closed by engaging dimples in fuse box ([Fig. 2](#)).
2. For 24- and 30-kW fused models:  
 Fuse assembly is mounted on heater. Be sure fuse cover is closed by engaging clip latch on unit top panel ([Fig. 1](#))

## ! WARNING

**ELECTRICAL SHOCK HAZARD**  
 Failure to follow this warning could result in personal injury or death. Ensure fuse box is closed before power is turned to ON position. There may be more than one power supply.

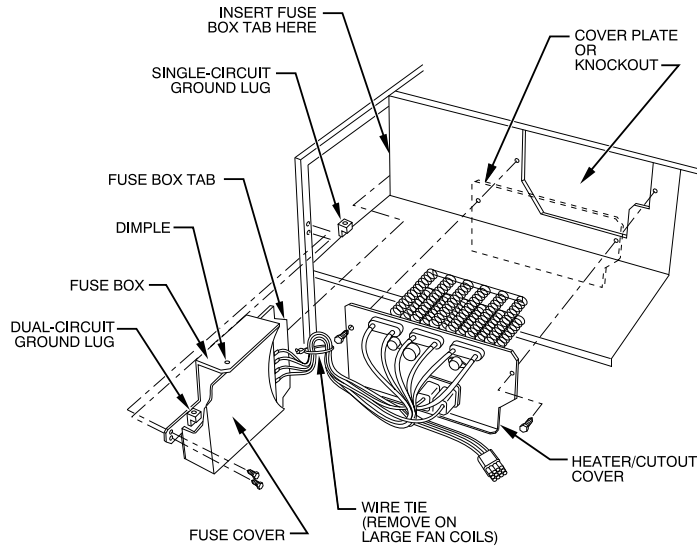

**Fig. 2 – Installation of Fused Model Heater**

A90151

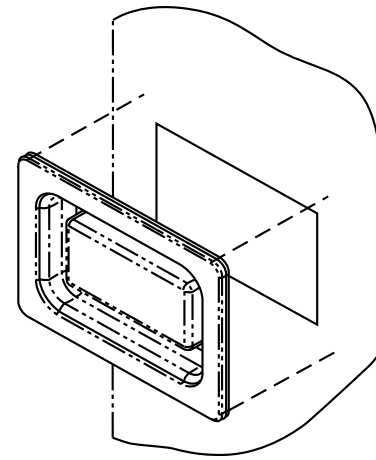

**Fig. 4 – Installation of Window Bezel for Circuit Breaker Model Heater**

A03069

3. For 5- through 20-kW circuit breaker models:  
After installing heater assembly, attach circuit breaker assembly to unit with screws provided (Fig. 3). On fan coil units size 42 and larger, remove wire tie that shortens wire length between heater and circuit breaker assembly to allow mounting of circuit breaker assembly (Fig. 3).

**Procedure 3 — Electrical Connections**

Refer to unit instructions for recommended wiring procedures. Install wiring in accordance with all applicable local and national codes, see Table 3 and Table 4. Connect heater wiring harness plug to receptacle on PCB or wire harness. A positive connection must be made between plug and receptacle. Plug will interlock with receptacle when properly seated. Harness contains both 24V control and high-voltage wiring. Blower power is provided through heater harness.

**NOTE:** Units with or without electric heaters require a minimum CFM. Refer to unit wiring label to ensure the fan speed selected with electric heaters is equal to or greater than the minimum fan speed indicated. The minimum CFM for cooling is determined by the outdoor unit requirements. Use the higher of the 2 for year-round operation.

**Wire 24V Control Systems**

1. **Connections to Unit**  
Use No. 18 AWG color-coded, insulated (35°C minimum) wire to make low-voltage connections between thermostat, fan coil unit, and outdoor unit. If thermostat is located more than 100 ft (20 m) from unit (as measured along the low-voltage wire), use No. 16 AWG color-coded, insulated (35°C minimum) wire. All wiring must be separated from line voltage power leads. Refer to outdoor unit wiring instructions for additional wiring procedure recommendations.
2. **Transformer**  
Transformer is factory wired for 230V operation. For 208V applications, disconnect black wire on transformer 230-v terminal and reconnect it to 208V terminal (Fig. 5). The secondary circuit of transformer is protected by a 5A fuse mounted on PCB.

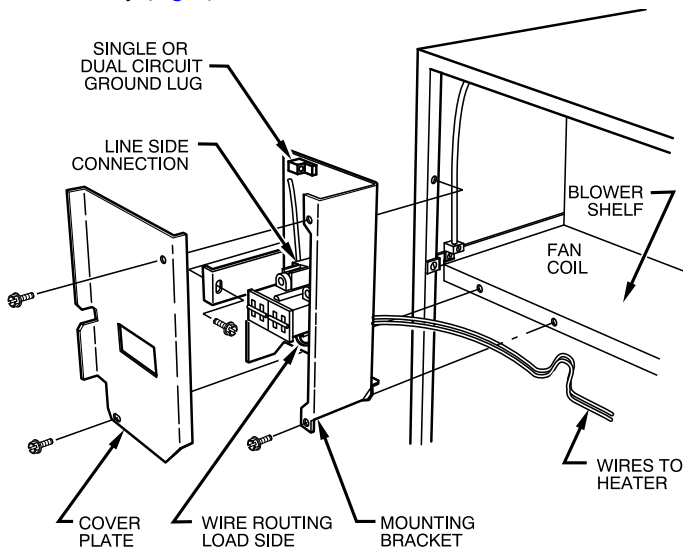

**Fig. 3 – Installation of Circuit Breaker Model Heater**

A90153A

4. Circuit breaker models require installing a window bezel in unit door to provide safe access to circuit breakers. The window bezel mounts on the outside of the blower door (Fig. 4).
  - a. Cut insulation away from rectangular access hole in blower access panel.
  - b. Remove adhesive backing from window bezel and from the outside. Insert the window through the rectangular hole and seat firmly on the door surface. Press firmly in place to seat the adhesive (Fig. 4).

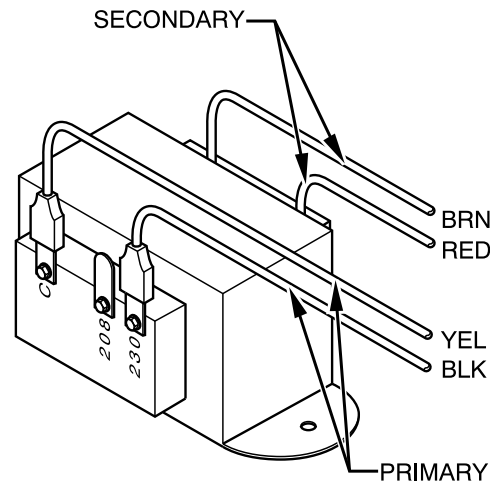

**Fig. 5 – Connection of Transformer**

A94067

### **For 3 kW through 10 kW non-fused or non-circuit breaker models:**

Refer to unit Installation Instructions for recommended wiring procedures.

Install wiring in accordance with all applicable local and national codes (see [Table 3](#) and [Table 4](#)).

3 kW through 10 kW non-fused or non-circuit breaker models have high voltage terminal block to connect the high voltage field wiring as shown in [Fig. 6](#).

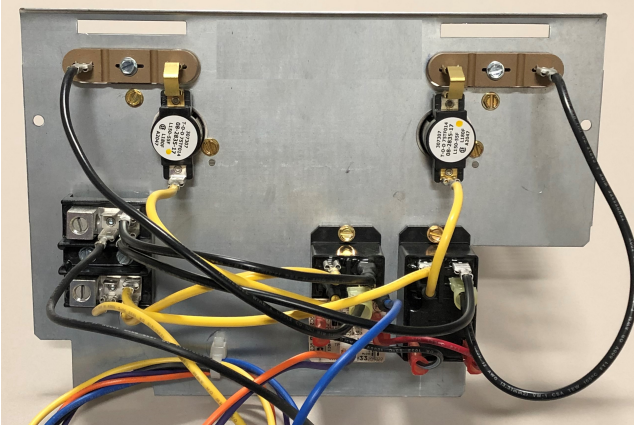

A221146

**Fig. 6 – 3kW through 10kW High Voltage Terminal Block for High voltage field Wiring**

1. Connect heater wiring harness plug to receptacle on PCB or wire harness. A positive connection must be made between plug and receptacle. Plug will interlock with receptacle when properly seated. Harness contains both 24V control and high voltage wiring. Blower power is provided through heater harness.
2. **Heater Staging**  
If electric heat staging is required, a multi-stage heating room thermostat is required. Consult your equipment supplier for a suitable thermostat.
  - a. The 3-, 5-, 8-, and 10-kW heaters are single stage only.
  - b. The 9- and 15-kW heaters are adaptable for 2-stage operation.
  - c. The 18-, 20-, 24-, and 30-kW heaters are adaptable for 3-stage operation.
3. **Rectifier and Time Delay Boards**  
Each heater element is controlled by a relay mounted on the heater panel. The relay has a 24V DC coil. Each relay has a small rectifier board attached directly to relay coil terminals. The rectifier board converts incoming 24V AC control signal to DC. Some heaters may have up to three relays. The second and/or third relay rectifier board also has a time delay feature and a small jumper wire built into it. With the jumper uncut, the time delay allows the second-stage heat to be energized approximately 5 seconds after the first stage. On 18-, 24-, and 30-kW heaters, the third-stage relay board jumper is cut at the factory. This provides an 8-second delay after first-stage relay closes.

**Table 3 – Electric Heater Electrical Data**

HEATER PART NO.	kW		PHASE	INTERNAL CIRCUIT PROTECTION	HEATER AMPS 208/230V			MIN AMPACITY 208/230V*			BRANCH CIRCUIT								
											Min Wire Size (AWG) 208/230V†			Min Gnd Wire Size 208/230V			Max Fuse/Ckt Bkr Amps 208/230V		
	240V	208V			Single Circuit	Dual Circuit		Single Circuit	Dual Circuit		Single Circuit	Dual Circuit		Single Circuit	Dual Circuit				
			L1,L2	L3,L4		L1,L2	L3,L4		L1,L2	L3,L4		L1,L2	L3,L4						
KFFEH0401N03A	3	2.3	1	None	10.9/12.0	—	—	17.3/18.6	—	—	12/12	—	—	12/12	—	—	20/20	—	—
KFFEH8401N03A	3	2.3	1	None	10.9/12.0	—	—	17.3/18.6	—	—	12/12	—	—	12/12	—	—	20/20	—	—
KFFEH0501N05A††	5	3.8	1	None	18.1/20.0	—	—	26.0/28.4	—	—	10/10	—	—	10/10	—	—	30/30	—	—
KFFEH8501N05A	5	3.8	1	None	18.1/20.0	—	—	26.3/28.6	—	—	10/10	—	—	10/10	—	—	30/30	—	—
KFFEH8501C05A	5	3.8	1	None	18.1/20.0	—	—	26.3/28.6	—	—	10/10	—	—	10/10	—	—	30/30	—	—
KFFEH0501N05A**	5	3.8	1	None	18.1/20.0	—	—	31.2/33.5	—	—	8/8	—	—	10/10	—	—	35/35	—	—
KFFEH2401C05A**	5	3.8	1	Ckt Bkr	18.1/20.0	—	—	31.2/33.5	—	—	8/8	—	—	10/10	—	—	35/35	—	—
KFFEH0801N08A	8	6.0	1	None	28.9/32.0	—	—	44.7/48.5	—	—	8/8	—	—	10/10	—	—	45/50	—	—
KFFEH8801N08A	8	6.0	1	None	28.9/32.0	—	—	39.8/43.6	—	—	8/8	—	—	10/10	—	—	45/50	—	—
KFFEH8501C08A	8	6.0	1	None	28.9/32.0	—	—	39.8/43.6	—	—	8/8	—	—	10/10	—	—	45/50	—	—
KFFEH2501C08A	8	6.0	1	Ckt Bkr	28.9/32.0	—	—	44.7/48.5	—	—	8/8	—	—	10/10	—	—	45/50	—	—
KFFEH2901N09A	9	6.8	1	None	32.8/36.0	—	—	49.5/53.5	—	—	8/6	—	—	10/10	—	—	50/60	—	—
KFFEH2901N09A††	9	6.8	3	None	18.8/20.8	—	—	32.0/34.5	—	—	8/8	—	—	10/10	—	—	35/35	—	—
KFFEH0901N10A	10	7.5	1	None	36.2/40.0	—	—	53.8/58.5	—	—	6/6	—	—	10/10	—	—	60/60	—	—
KFFEH8901N10A	10	7.5	1	None	36.2/40.0	—	—	48.9/53.6	—	—	6/6	—	—	10/10	—	—	60/60	—	—
KFFEH8601C10A	10	7.5	1	None	36.2/40.0	—	—	48.9/53.6	—	—	6/6	—	—	10/10	—	—	60/60	—	—
KFFEH2601C10A	10	7.5	1	Ckt Bkr	36.2/40.0	—	—	53.8/58.5	—	—	6/6	—	—	10/10	—	—	60/60	—	—
KFFEH3001F15A††	15	11.3	1	Fuse	54.2/59.9	36.2/40.0	18.1/20.0	76.3/83.4	53.8/58.5	22.7/25.0	4/4	6/6	10/10	8/8	10/10	10/10	80/90	60/60	25/25
KFFEH3101C15A	15	11.3	1	Ckt Bkr	—	36.2/40.0	18.1/20.0	—	53.8/58.5	22.7/25.0	—	6/6	10/10	—	10/10	10/10	—	60/60	25/25
KFFEH1601315A	15	11.3	3	None	31.3/34.6	—	—	47.7/51.8	—	—	8/6	—	—	10/10	—	—	50/60	—	—
KFFEH2001318A	18	13.5	3	None	37.6/41.5	—	—	55.5/60.4	—	—	6/6	—	—	10/8	—	—	60/70	—	—
KFFEH3201F20A††	20	15.0	1	Fuse	72.3/79.9	36.2/40.0	36.2/40.0	98.9/108.4	53.8/58.5	45.3/50.0	3/2	6/6	8/8	8/6	10/10	10/10	100/110	60/60	50/50
KFFEH3301C20A	20	15.0	1	Ckt Bkr	—	36.2/40.0	36.2/40.0	—	53.8/58.5	45.3/50.0	—	6/6	8/8	—	10/10	10/10	—	60/60	50/50
KFFEH3401F24A***	24	18.0	3	Fuse	50.1/55.4	—	—	71.2/77.8	—	—	4/4	—	—	8/8	—	—	80/80	—	—
	24	18.0	1	Fuse	86.7/95.5	—	—	116.9/127.9	—	—	1/1	—	—	6/6	—	—	125/150	—	—
KFFEH3501F30A***	30	22.5	3	Fuse	62.6/69.2	—	—	86.8/95.0	—	—	3/3	—	—	8/8	—	—	90/100	—	—
	30	22.5	1	Fuse	109.0/120.0	—	—	144.8/158.5	—	—	0/00	—	—	6/6	—	—	150/175	—	—

\*. Includes blower motor amps of largest fan coil used with heater.

†. Copper wire must be used. If other than uncoated (non-plated), 75°C ambient, copper wire (solid wire for 10 AWG and smaller, stranded wire for larger than 10 AWG) is used, consult applicable tables of the National Electric Code (ANSI/NFPA 70).

‡. For fan coil sizes 24–42.

\*\*. For fan coil sizes 48–60.

††. Field convertible to 3 phase.

‡‡. Single circuit application of F15 and F20 heaters requires single-point wiring kit accessory.

\*\*\*. Field convertible to 1 phase, single or multiple supply circuit.

**Table 4 – Field Multipoint Wiring or 24- and 30-kW Single Phase**

HEATER PART NO.	kW		PHASE	HEATER AMPS 208/230V			MIN AMPACITY 208/230V*			MIN WIRE SIZE (AWG) 208/230V†			MIN GND WIRE SIZE 208/230V	MAX FUSE/CKT BKR AMPS 208/230V			MAX WIRE LENGTH 208/230V (FT)‡		
	240V	208V		L1,L2	L3,L4	L5,L6	L1,L2	L3,L4	L5,L6	L1,L2	L3,L4	L5,L6		L1,L2	L3,L4	L5,L6	L1,L2	L3,L4	L5,L6
KFFEH3401F24**	24	18.0	1	28.9/32.0	28.9/32.0	28.9/32.0	44.7/48.5	36.2/40.0	36.2/40.0	8/8	8/8	8/8	10/10	45/50	40/40	40/40	59/60	73/73	73/73
KFFEH3501F30**	30	22.5	1	36.2/40.0	36.2/40.0	36.2/40.0	53.8/58.5	45.3/50.0	45.3/50.0	6/6	8/8	8/8	10/10	60/60	50/50	50/50	78/80	59/59	59/59

\*. Includes blower motor amps of largest fan coil used with heater.

†. Copper wire must be used. If other than uncoated (non-plated), 75°C ambient, copper wire (solid wire for 10 AWG and smaller, stranded wire for larger than 10 AWG) is used, consult applicable tables of the NEC (ANSI/NFPA 70).

‡. Length shown is as measured 1 way along wire path between unit and service panel for a voltage drop not to exceed 2%.

\*\*.

Manufacturer reserves the right to change, at any time, specifications and designs without notice and without obligations.

**Power Connections**

**NOTE:** Heater supply circuit wire size and over-current protection must comply with National Electrical Code (NEC) and UL branch circuit requirements, see [Table 3](#) and [Table 4](#). Wires and over-current protection, integral to the heater, are not required to meet branch circuit requirements. Internal circuit protection of 60A (maximum) is acceptable.

1. Unprotected heaters: See [Fig. 7](#), [Fig. 11](#), and [Fig. 12](#).
  - a. The 5- through 10-kW single-phase and 15- and 18-kW 3-phase heaters can be wired for single-supply circuit only. Supply circuit connects to terminal block. For 15 and 18kW 3-phase heaters, wire the supply circuit to the heater pigtail leads.
  - b. The 3- through 10-kW single-phase heaters can use a separate field-installed, factory-authorized disconnect kit which installs in the fan coil.

**NOTE:** Refer to wiring label for component locations.

- c. The 9-kW heater is factory wired for a single supply circuit, single phase. To convert the heater to a single supply circuit, 3-phase:
  - (1.) Disconnect the blue wire from Relay 1, Terminal 6. Cut, strip, and connect to field wire L3.
  - (2.) Disconnect the yellow wire from Relay 3, Terminal 6 and connect to Relay 1, Terminal 6.
  - (3.) Disconnect the blue wire from Relay 3, Terminal 2 and connect to Relay 3, Terminal 6.
2. Circuit breaker heaters: See [Fig. 8](#) and [Fig. 10](#).
  - a. The 3- through 10-kW heaters can be wired for a single-supply circuit only.
  - b. The 15- and 20-kW heaters can be wired for dual-supply circuits only.

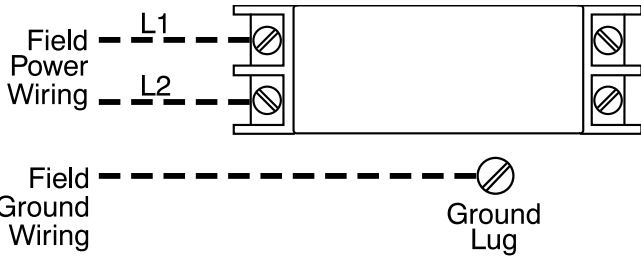

**Fig. 7 – 3, 5, 8, 9 10 kW Non-fused Heaters (9 kW is field convertible to 3-phase. See (Power Connections on p6).**

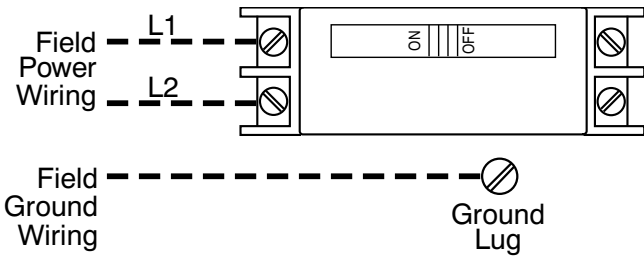

**Fig. 8 – 5, 8 10 kW Circuit Breaker and Disconnect Heaters**

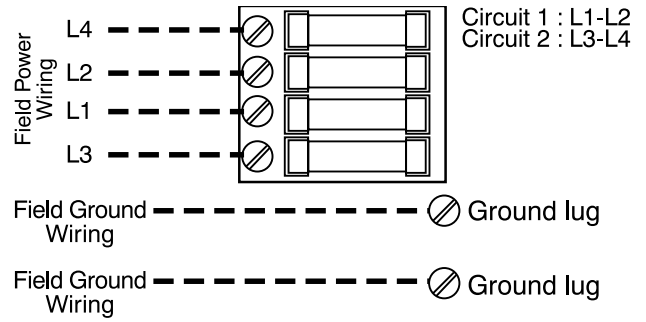

**Fig. 9 – 15 and 20 kW Fused Heaters (15 and 20 kW fused heaters are factory wired for dual supply circuits. Single supply circuit is possible with approved single point wiring kit.)**

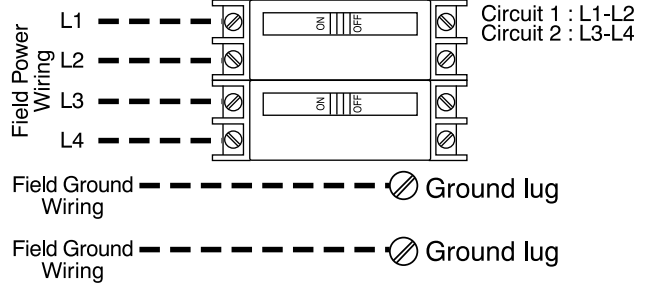

**Fig. 10 – 15 and 20 kW Circuit Breaker Heaters**

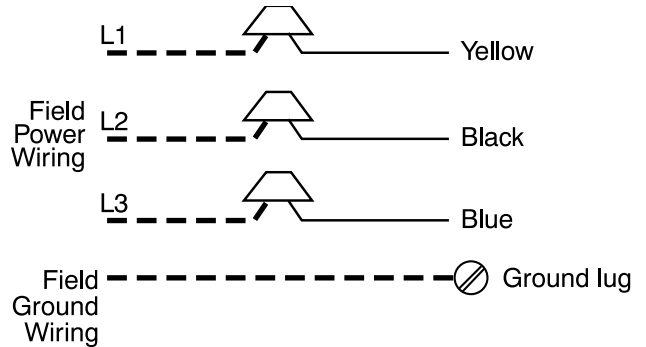

**Fig. 11 – 15 kW 3-Phase Heater**

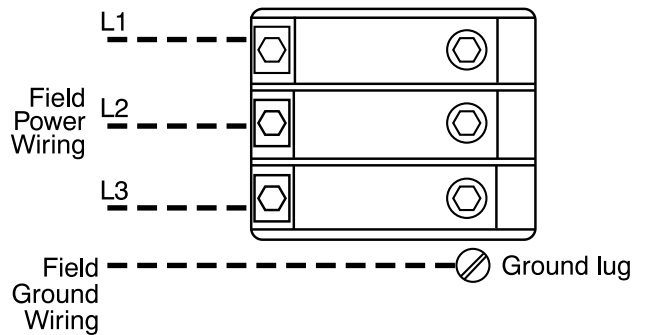

**Fig. 12 – 18 kW 3-Phase Heater**

3. Fused heaters: See [Fig. 9](#), [Fig. 13](#), [Fig. 14](#), and [Fig. 15](#).
  - a. The 15- and 20-kW heaters can be wired for single- or dual-supply circuits. Single-supply circuit wiring requires a factory-authorized, single-point adapter kit.
  - b. The 24- and 30-kW heaters can be wired for single- or multiple-supply circuits. Heaters are factory wired for single circuit 3-phase. To convert heaters to single-circuit single-phase, disconnect the yellow lead from L3 and connect it to L1. Disconnect the black lead from L3 and connect it to L2. To convert heaters to multiple-supply circuit single-phase, remove and discard the leads between the single-circuit terminal block

and fuse block. Remove and discard the single-circuit terminal block. Attach L1 through L6 power leads as indicated on the label next to the fuse block.

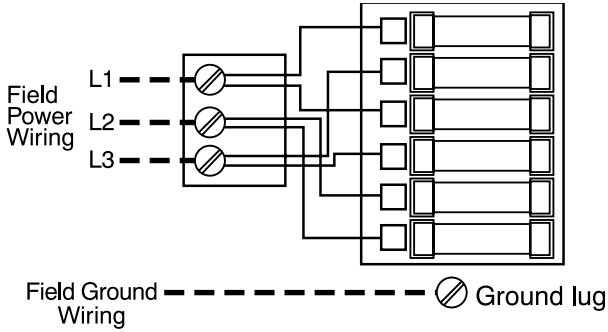

A00082

Fig. 13 – 24 and 30 kW Heaters (3-Phase Wiring Factory Supplied)

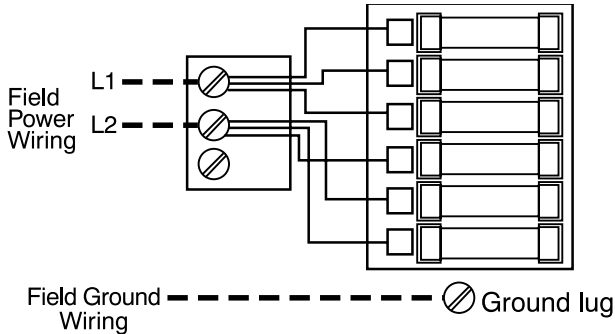

A00083

Fig. 14 – 24 and 30 kW Heaters (Single Phase, Single Supply Circuit-Field Modified)

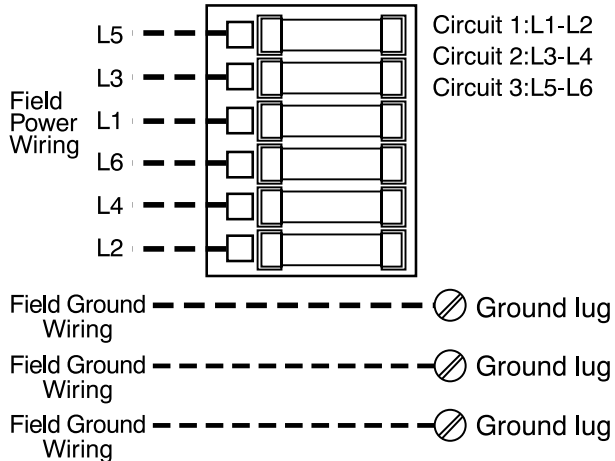

A00084

Fig. 15 – 24 and 30 kW Heaters (Single Phase, Multiple Supply Circuits-Field Modified)

**Ground Connections**

**⚠ WARNING**

**ELECTRICAL SHOCK HAZARD**

Failure to follow this warning could result in personal injury or death. According to NEC, ANSI/NFPA 70, and local codes, cabinet must have an uninterrupted or unbroken ground to minimize personal injury if an electrical fault should occur. The ground may consist of electrical wire or metal conduit when installed in accordance with existing electrical codes. (See Gound/Conduit NOTE below.)

**NOTE:** Use UL-listed conduit and conduit connector for connecting supply wire(s) to unit to obtain proper grounding. If the conduit connection uses reducing washers, a separate ground wire must be used.

Grounding may also be accomplished by using grounding lugs provided in the control box.

1. For unprotected or single-circuit heaters, one (1) equipment ground connection is provided on the fan coil unit (Fig. 1 or Fig. 2).
2. For 15- and 20-kW circuit breaker heaters, an additional ground lug is provided on the circuit breaker mounting bracket for dual-circuit grounding (Fig. 3).
3. For 15- and 20-kW fused heaters, an additional ground lug is provided on the fuse mounting bracket for dual-circuit grounding (Fig. 2).
4. For 24- and 30-kW fused heaters, two (2) additional ground lugs are provided for single-phase, multi-circuit wiring (Fig. 1).

**Fan Speeds for FJ4 and PF4MNX**

1. Speed tap selection is done at the fan relay. To change motor speeds, disconnect the fan lead on the relay and replace with the motor speed tap desired. Save the insulating cap and place it on the motor lead that was removed from the relay (Fig. 16). Refer to Table 5 for further clarification of speed tap selections.

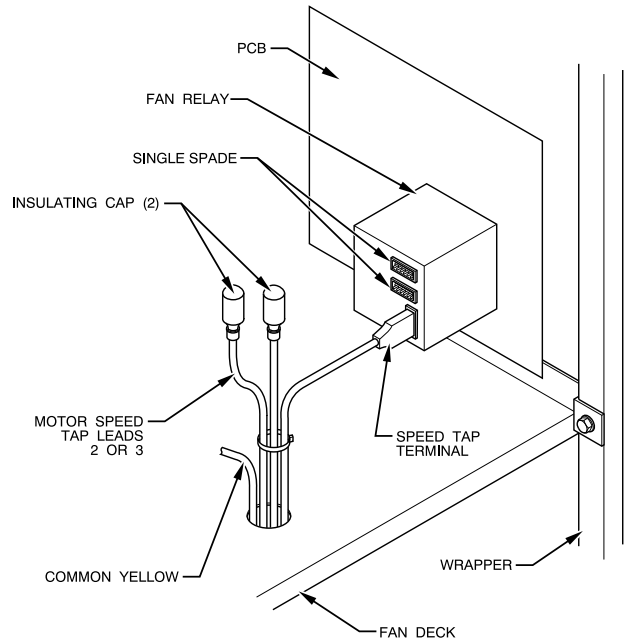

A94068

Fig. 16 – PSC Motor Speed Tap and Fan Relay

Table 5 – Color Code for Motor Lead Wires FJ4 and PF4MNX

MOTOR SPEED TAP	WIRE COLOR
Common	Yellow
High	Black
Medium	Blue (Factory selected)
Low	Red (Blue on 2-speed models)

**FJ4 and PF4MNX with Discrete Tap BLDC Motors**

1. Speed tap selection is done at the motor terminals. To change motor speed, disconnect the motor lead from the factory terminal and move it to the desired speed tap based on published airflow tables and desired unit function.
2. Electric heat (white wire) should remain plugged into Tap 4.

**Procedure 4 – Conversion of Circuit Breaker for Downflow Applications**

1. Tag and disconnect factory wiring from terminals on circuit breaker(s).
2. Pull the white plastic release tab on the bottom of circuit breaker straight out to release the circuit breaker from the bracket (Fig. 17).

3. Remove the quick connect adapters from the factory side of the breaker(s). Reinstall the adapters on the other end of the breakers(s). Be sure the adapter is located between the lug screw and plate. Torque the lug screw to 30 in-lb.
4. Rotate the breaker 180° from its original position and reinstall in the bracket. Slide the breaker slot into the sheet metal tab and snap the breaker into place. Make sure both tabs engage the breaker. Reconnect wiring on the opposite end. Make sure the wires are positioned as before.
5. Remount the circuit breaker bracket into the unit so that the switch will be in the UP position when ON.

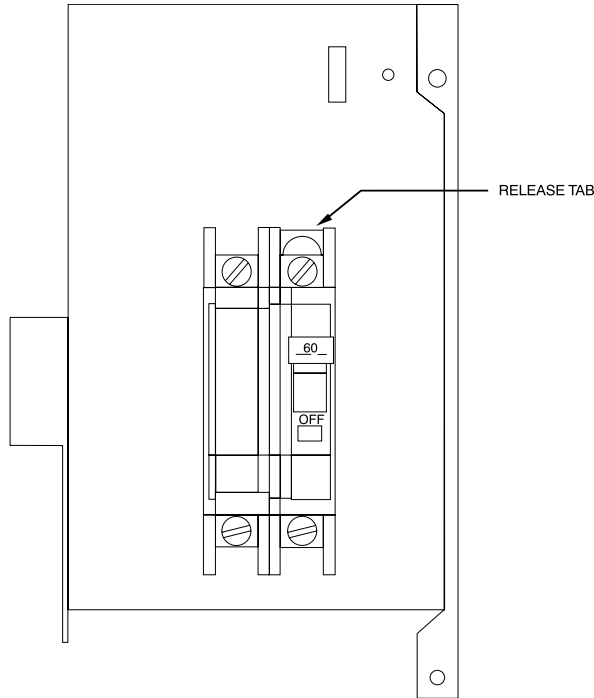

Fig. 17 – Conversion of Circuit Breaker

A99094

### Procedure 5 — Attach Wiring Diagram and Rating Label

Attach the heater rating label included with the kit over the existing electrical information label located on the front access panel of the fan coil (Fig. 18). If the kit contains multiple rating labels, make sure the correct label is applied (check phase and supply circuits). Affix the wiring diagram label #3, included with the kit, on the blower housing above the fan coil wiring label. Do not cover up the existing wiring label.

**NOTE:** The fact there is a label #3 does not imply there should be label #1 or #2. These kits have only one wiring label – label #3.

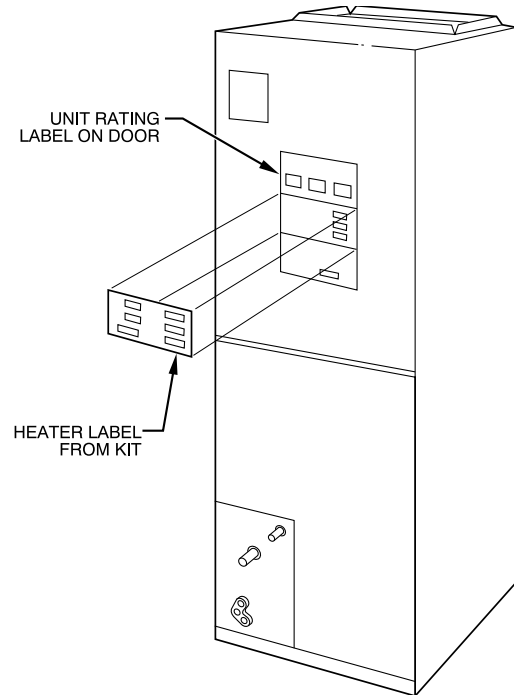

Fig. 18 – Heater Rating Label Location

A96251

### Procedure 6 — Verify Installation

After completion of the heater installation, check the wiring to ensure tightness and that proper connections and routings have been made. Make sure all electrical covers are in place and proper labels have been applied. Reinstall the blower access panel before turning on the unit power.