

Low Lead High Flow Thermostatic Mixing Valves

© Copyright 2014 Caleffi

5231 Series

Installation, commissioning and service instructions



Function

ASSE 1017 model 5231 series high flow thermostatic mixing valves are designed to be installed at the hot water heater (point of distribution) and cannot be used for tempering water temperature at fixtures as a point-of-use valve. They are not designed to provide scald protection and should not be used where ASSE 1070 devices are required. Wherever a scald protection feature is required, ASSE 1070 model mixing valves must be installed. For safety reasons, it is advisable to limit the maximum mixed water temperature to 120°F. Series 5231 thermostatic mixing valves can also be used for regulating the flow temperature in radiant panel heating systems, to which it assures a constant and accurate control with ease of installation.

Product range

5231 series thermostatic mixing valve. Union thread NPT male and union sweat connections, sizes 1", 1-1/4", 1-1/2", 2".

Technical characteristics

Materials:

- body: low-lead brass (<0.25% Lead content)
- shutter: brass
- springs: stainless steel
- seals: EPDM

Suitable fluids: water

Max. percentage of glycol: 30% glycol solution

Setting range: see table on page 2

Temperature stability: ± 5°F (± 3°C)

Max. working pressure (static): 200 psi (14 bar)

Max. working pressure (dynamic): 70 psi (5 bar)

Hot water inlet temperature range: 120 – 195°F (49 – 91°C)

Cold water inlet temperature range: 39 – 80°F (3.9 – 26.6°C)

Mixed temperature range: 90 – 150°F (32 – 66°C)

Max. inlet pressure ratio (H/C or C/H): 2:1

Min. temperature difference between hot water inlet and mixed water outlet for optimum performance: 20°F (11°C)

Max. water hardness: 10 grains

Certified to: *cUPC listed to ASSE 1017/CSA B125.3

Reduction of Lead in Drinking Water Act Compliant: 0.25% Max. weighted average lead content. Reduction of lead in Drinking Water Act Certified by IAPMO R&T.

*Listing pending for the 1" and 1¼" sizes.



ASSE 1017



C

Code	Description	Flow
523160A*	1" Union Thread NPT male	4.4 Cv
523168A*	1" Union Sweat	4.4 Cv
523170A*	1-1/4" Union Thread NPT male	4.4 Cv
523178A*	1-1/4" Union Sweat	4.4 Cv
523177A*	1-1/4" Union Sweat with outlet temp. gauge	4.4 Cv
523180A	1-1/2" Union Thread NPT male	8.8 Cv
523188A	1-1/2" Union Sweat	8.8 Cv
523190A	2" Union Thread NPT male	8.8 Cv
523198A	2" Union Sweat	8.8 Cv

*Note: cUPC Listing pending

Setting the temperature

The temperature is set to the required value by means of the adjustment knob with the graduated scale on the top of the valve

Pos.	Min	1	2	3	4	5	6	7	Max
T (°F)	95	104	109	117	122	129	136	142	150
T (°C)	35	40	43	47	50	54	58	61	66

with: $T_{HOT} = 155^{\circ}F (68^{\circ}C)$ · $T_{COLD} = 55^{\circ}F (13^{\circ}C)$ · $P_{INLETS} = 43 \text{ psi (3 bar)}$

Replacement fitting part numbers

Code	Description	Tailpiece all ports (3)	Union nuts (3)	Gaskets (3)
523160A	1" Union Thread NPT male	NA10009	R31589	R50057
523168A	1" Union Sweat	31554 FD		
523170A	1-1/4" Union Thread NPT male	R41660		
523178A	1-1/4" Union Sweat	41787 CST		
523177A	1-1/4" Union Sweat with outlet temp. gauge*	41787 CST (2 only)	R31589 (2 only)	R50057 (2 only)
523180A	1-1/2" Union Thread NPT male	41371A	R51838	R50060
523188A	1-1/2" Union Sweat	41788 CST		
523190A	2" Union Thread NPT male	41372A		
523198A	2" Union Sweat	41789 CST		

*Replacement outlet mixed temperature gauge adapter complete with outlet tailpiece, union nut and gasket, and temperature gauge (30-210°F), code NA10315.

Recommended flow rates for temperature stability:

	Min. (gpm)	Max. (gpm)	Cv
1"	4.4	40	7
1-1/4"			7.6
1-1/2"	8.8	70	13
2"			14.2

Flow curves

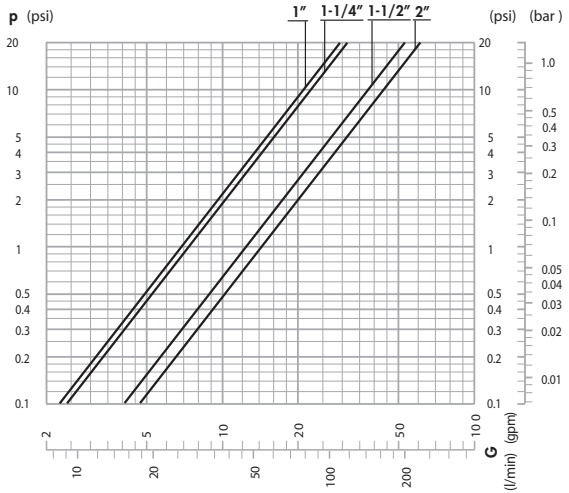

Principle of Operation

A thermostatic mixing valve mixes hot and cold water in such a way as to maintain a constant set temperature of the mixed water at the outlet. A thermostatic element is fully immersed into the mixed water. It then contracts or expands causing movement of the piston, closing either the hot or cold inlets, regulating the flow rates entering the valve.

If there are variations of temperature or pressure at the inlets, the internal element automatically reacts attempting to restore the original temperature setting.

Thermal Shutoff

In the event of a failure of either the hot or cold supply, the piston will shut off, stopping water discharging from the mixed water outlet.

The Caleffi 5230 and 5231 series mixing valves require a minimum temperature differential from hot inlet to mixed water outlet of 20°F (11°C) to ensure the correct operation of the thermal shutoff feature. Softened water use is highly recommended as the warranty is voided if used on water with hardness greater than 10 grains.

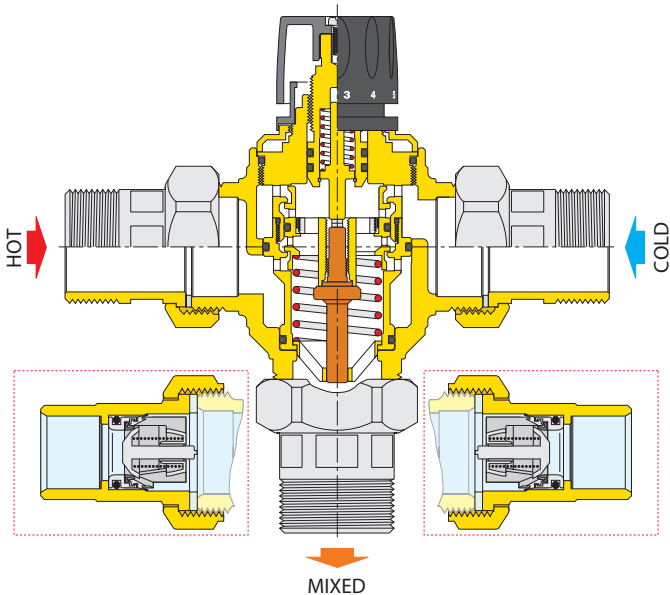



SAFETY INSTRUCTION

This safety alert symbol will be used in this manual to draw attention to safety related instructions. When used, the safety alert symbol means **ATTENTION! BECOME ALERT! YOUR SAFETY IS INVOLVED! FAILURE TO FOLLOW THESE INSTRUCTIONS MAY RESULT IN A SAFETY HAZARD.**



CAUTION: All work must be performed by qualified personnel trained in the proper application, installation, and maintenance of systems in accordance with all applicable codes and ordinances.



CAUTION: If the thermostatic mixing valve is not installed, commissioned and maintained properly, according to the instructions contained in this manual, it may not operate correctly and may endanger the user.



CAUTION: Make sure that all the connecting pipework is water tight.



CAUTION: When making the water connections, make sure that the mixing valve connecting pipework is not mechanically over-stressed. Over time this could cause breakages, with consequent water losses which, in turn, could cause harm to property and/or people.



CAUTION: Water temperatures higher than 100°F can be dangerous. During the installation, commissioning and maintenance of the thermostatic mixing valve, take the necessary precautions to ensure that such temperatures do not endanger people.



CAUTION: In the case of highly aggressive water, arrangements must be made to treat the water before it enters the thermostatic mixing valve, in accordance with current legislation. Otherwise the mixing valve may be damaged and will not operate correctly.

Leave this manual for the user.

Use



Caleffi 5231 series thermostatic mixing valves are designed to be installed at the hot water heater and cannot be used for tempering water temperature at fixtures as a point-of-use valve. They are not designed to provide scald protection or chill protection service and should not be used where ASSE 1070 devices are required. Wherever a scald protection feature is required, ASSE 1070 model mixing valves need to be installed. For safety reasons, it is advisable to limit the maximum mixed water temperature to 120°F.

Instantaneous production of hot water

Caleffi 5231 series thermostatic mixing valves should not be used in conjunction with boilers giving instantaneous production of domestic hot water. Their addition would compromise the correct operation of the boiler itself.

Installation

Before installing a Caleffi 5231 series thermostatic mixing valve, the system must be inspected to ensure that its operating conditions are within the range of the mixing valve, checking, for example, the supply temperature, supply pressure, etc.



Systems where the Caleffi 5231 series thermostatic mixing valve is to be fitted must be drained and cleaned out to remove any dirt or debris which may have accumulated during installation.

Failure to remove dirt or debris may affect performance and the manufacturer's product guarantee. Softened water use is highly recommended as the warranty is voided if used on water with hardness greater than 10 grains.

The installation of filters of appropriate capacity at the inlet of the water from the mains supply is always advisable.

In areas which are subject to highly aggressive water, arrangements must be made to treat the water before it enters the valve.

Caleffi 5231 series thermostatic mixing valves must be installed in accordance with the diagrams in this manual, taking into account all current applicable standards.

Caleffi 5231 series thermostatic mixing valves can be installed in any position, either vertical or horizontal.

The following are shown on the mixing valve body:

- Hot water inlet, "H".
- Cold water inlet, "C".
- Mixed water outlet, unmarked.

In systems with thermostatic mixing valves, check valves must be installed to prevent undesirable fluid backflow. The 5231 series valves, codes listed in this instruction sheet, do not contain integral check valves, so those must be sourced separately.

It is essential that access to the valve is totally unobstructed for any maintenance which may be required to the valve or connections. The pipework from/to the valve must not be used to support the weight of the valve itself.

Application diagrams

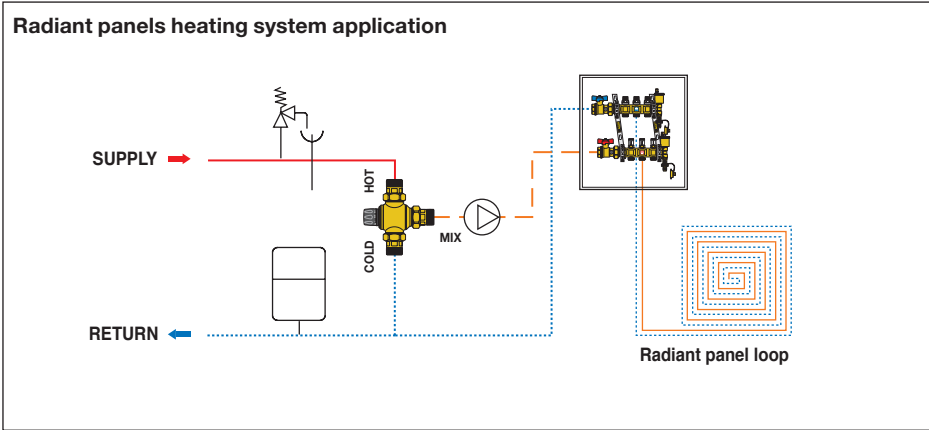
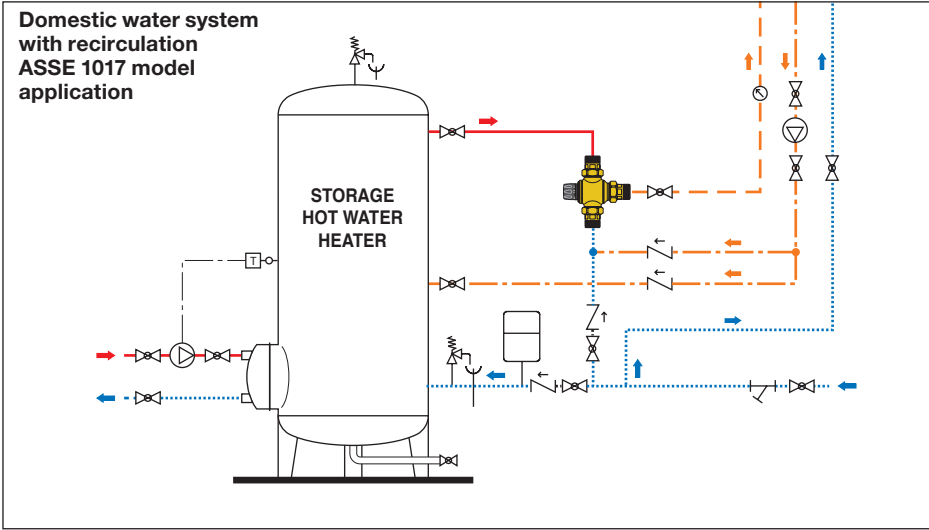
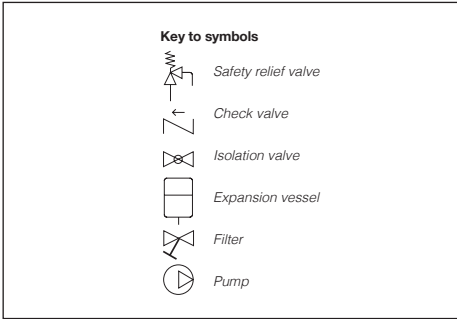
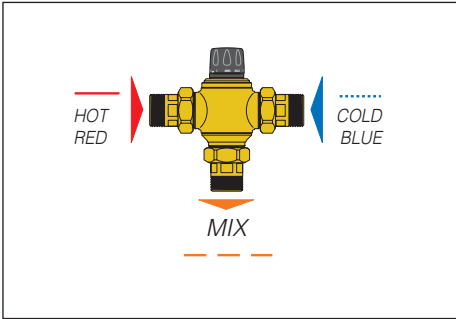

Commissioning

After installation, the valve must be tested and commissioned in accordance with the instructions given below, taking into account current applicable standards.

- 1) Ensure that the system is clean and free from any dirt or debris before commissioning the thermostatic mixing valve. Be sure water hardness is less than 10 grains.
- 2) It is recommended that the temperature is set using a suitable calibrated digital thermometer. The valve must be commissioned by measuring the temperature of the mixed water at the outlet.
- 3) The maximum outlet temperature from the valve must be set taking account of the fluctuations due to simultaneous use. It is essential for these conditions to be stabilized before commissioning.
- 4) Adjust the temperature using the adjusting knob on the valve. For safety reasons, it is advisable to limit the maximum mixed water temperature to 120°F in domestic hot water systems.

Preset locking

Position the handle to the number required. Unscrew the head screw, pull off the handle and reposition it so that the handle fits into the internal slot of the knob. Tighten the head screw.

Maintenance

Service tests should be carried out regularly to monitor the mixing valve performance, as deterioration of performance could indicate that the valve and/or the system require maintenance. If, during these tests, the temperature of the mixed water has changed significantly in comparison with the previous test, the details given in the installation and commissioning sections should be checked and maintenance carried out.

The following aspects should be checked regularly to ensure that the optimum performance levels of the valve are maintained. Every 12 months at least, or more often if necessary.

- 1) Check and clean the system filters.
- 2) Check that any non-return valves positioned upstream of the Caleffi valve are operating correctly, without problems caused by impurities.
- 3) Limescale can be removed from internal components by immersion in a suitable de-scaling fluid.
- 4) When the components which can be maintained have been checked, commissioning should be carried out again.

Troubleshooting

Under normal operating conditions the Caleffi 5231 series thermostatic mixing valve will provide a very high level of performance. However, in some circumstances, where our maintenance plan is not followed, the following problems may arise.

Symptom	Cause	Corrective action
Hot water at the cold taps	a) Operation of check valve is hindered; check valve is not sealing correctly b) Check valves not fitted	• Replace faulty check valves
Fluctuating mixer water temperature	a) Erratic supply temperatures at the inlets of the valve b) Starvation of the water supplies at the inlets of the valve c) Incorrect commissioning of the valve	• Restore inlet conditions within the limits of the valve
Erratic flow of water from the valve	a) Insufficient water supplies b) Fluctuations in supply pressures/temperatures c) Adverse effect created by other draw off points on the system	• Stabilize inlet supply conditions
No flow of water from the valve	a) In-line filters blocked b) Insufficient supply pressures c) Debris obstructing valve operation	• Clean filters • Restore inlet supplies • Clean debris or scale from valve



Caleffi North America, Inc.
3883 West Milwaukee Road
Milwaukee, WI 53208
T: 414.238.2360 F: 414.238.2366