

HYDROFILL™ water treatment filling unit

series NA5709



01288/16 NA



Function

HYDROFILL™ is a portable water treatment filling unit that produces ideal grade demineralized water from site sourced water for use in closed loop hydronic systems. Minerals causing hardness are almost entirely eliminated. This prevents premature equipment malfunction including reduced efficiency or component failure due to lime scale formation – a common affliction of heat exchangers. Aggressive minerals like chlorides and sulfates are also eliminated, which can attack aluminum, stainless steel and copper.

Demineralized water is low in electrical conductivity to minimize corrosion due to galvanic attack. Demineralized water eliminates the variability of mineral content found in untreated site water which provides more reliable dosing when chemical additives are used – such as glycol

In the demineralization process, the minerals responsible for producing hardness and conductivity are removed from the water through an ion exchange process. Minerals are referred to as total dissolved solids (TDS) and are measured in parts per million (ppm). The average TDS of tap water is 180 ppm. Water is considered 100% demineralized when its TDS is measured at 0 ppm, water with TDS less than 30 ppm is considered ideal for closed loop hydronic systems.

Product range

Code NA570912 Portable water treatment filling unit with casters complete including two resin bags

6 gpm filling rate

Code NA570924 Portable water treatment filling unit with cart complete including four resin bags

12 gpm filling rate

Code NA570971 Two replenishment resin bags in plastic bucket with lid

Code NA570974 Four replenishment resin bags in plastic bucket with lid

Technical specifications

Filling unit body

Materials:

- Body and cover: PP-H A GF50
- Screen: stainless steel
- Seals: EPDM

Shut-off ball valve

- Body: brass
- Ball: stainless steel
- Seals: EPDM

TDS meter

- Range: 0 to 9990 ppm
- Resolution: 1 ppm
- Accuracy: ±2%
- Battery: 2 x 1.5V button cell (LR44/ 357A)
- Battery life: approx. 1000 hours of continuous use

Filling unit cart (NA570924 only)

Materials:

- Frame: stainless steel
- Hardware: stainless steel
- Wheels: semi pneumatic rubber

Disposable resin bags

Material:

- Bag: nylon
- Contents: strong base mixed bed resins

Resin volume:

- Two bags: 3¼ gallons
- Four bags: 6½ gallons

Resin coefficient:

- Two bags: 1800
- Four bags: 3600

Resin exchange:

- Anion: 60%
- Cation: 40%

Performances

- Medium: tap water
- Maximum working pressure: 120 psi
- Working temperature range: 40 – 100°F
- Storage temperature range: 15°F – 120°F
- TDS of water after treatment: < 30 ppm
- Connections: 3/4" GHT

Dimensions

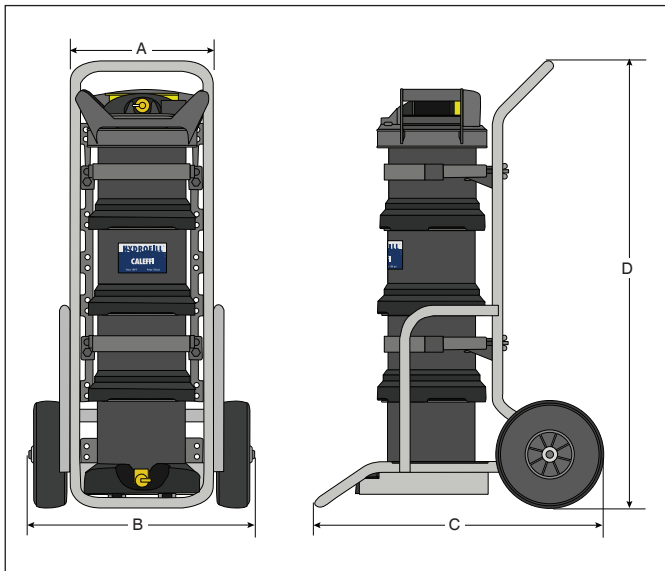

Code	A	B	C	D	Wgt. Lbs.
NA570924	13½"	21"	27"	42½"	98

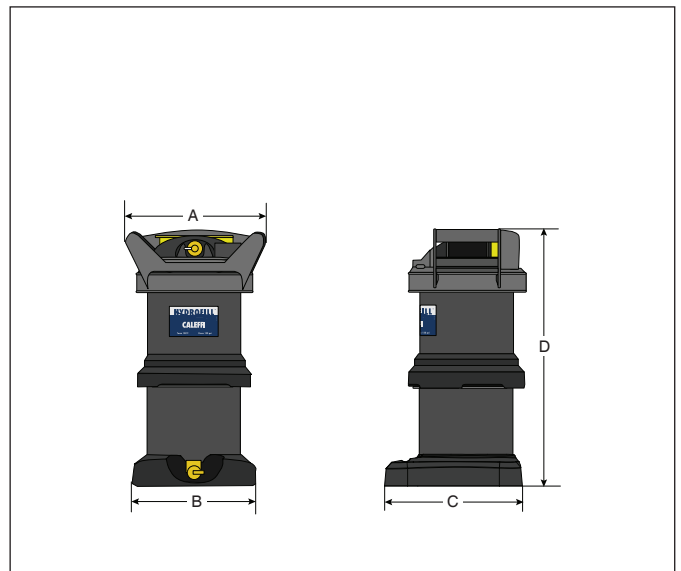

Code	A	B	C	D	Wgt. Lbs.
NA570912	13"	11"	12"	22"	44

Characteristic components



1. Water IN connection
2. Water OUT connection
3. Quick opening lever to release pressure and open
4. TDS-Meter
5. Handles to carry and open
6. Tank
7. Resin Bags
8. Cart (NA570924 only)

Construction details

Large yellow lever offers an easy & quick opening of the tank. This includes a pressure valve, so pressure can be released easily before opening. In one motion you can press and turn the lid to open the full diameter of the tank.



Highly accurate built-in TDS meter with wide range of 0 - 9990 ppm, the resolution is 1 ppm. Auto-Off function conserves battery power. The unit shuts off automatically after 10 minutes of non-use. Replaceable battery with a life of approximately 1000 hours of continuous use.

Pre-packed resin bags save time and simplify resin change process. No more time-consuming, inconvenient filling up of narrow tanks and no more spilled, wasted resin. Resin change process as simple as removing the used bags and insert new ones. Each bag is made from a water permeable material and contains a pre-proportioned amount of high capacity premium grade virgin mixed bed resin.

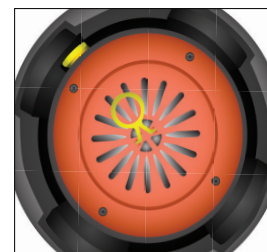
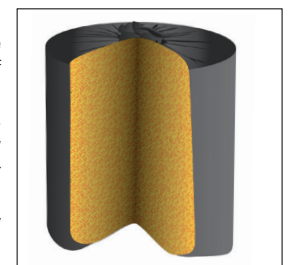

Innovative flow distribution screen design evenly distributes the inlet water over the complete column of resin. Producing up to 30% more treated water from a single resin refill compared to other types of demineralization tanks. Reduced operational cost through less frequent resin replacement. Less waste, less time spent on changing resin.

Operation

HYDROFILL™ is a portable water treatment filling unit which converts site tap water into demineralized water of an ideal grade for use in closed loop hydronic systems. Site water contains soluble minerals which exist as positive or negative molecules. Mixed bed resin beads are charged with positive hydrogen (H+) and negative hydroxide (OH-) molecules. As water flows up through the column of mixed bed resin beads, the soluble minerals are “exchanged” with either hydrogen or hydroxide, the two then combine to form H₂O (e.g., pure water). In effect, the soluble minerals are “pulled” from the site water and are replaced with pure water.

HYDROFILL's high capacity premium grade virgin mixed bed resin has 40% positive charge Cations and 60% negative charged Anions. This special mixed blend increases demineralized water capacity over cheaper 50% / 50% blend commonly used in standard loose filled resin tanks.

No power is required, tap water line pressure is used, which typically ranges from 40 to 60 psi. When tap water line pressure falls below 40 psi, a reduction in flow rate will be noticeable. The production of demineralized water is not sensitive to water temperatures. It is recommended to test the water supply (TDS) before start up. Mixed bed ion exchange resin eventually becomes exhausted and no longer able to remove impurities.

The HYDROFILL™ unit incorporates an on-board TDS meter. TDS is a measure of how pure the water is. Water is considered demineralized when its TDS is measured at less than 30 ppm and is ideal for closed loop hydronic systems. When TDS levels reach over 30 ppm, the resin should be replaced. Changing the resin bags is quick and easy.

Flow design



The HYDROFILL's permeable resin bags are tightly packed to allow water to flow evenly through each bag. Its unique upward flow and innovative flow distribution screen design evenly distributes the bottom inlet water over the complete column of resin. Producing up to 30% more treated water from a resin refill compared to other types of standard loosed filled resin tanks. Water flows evenly up through the entire column of resin treating 100% of water.



Standard resin tanks are filled with loose resin. The inlet water enters through the top and is forced down the center tube. Then the water is forced up through the loose resin bed. Water takes the path of least resistance and creates water channels up through the resin allowing untreated water to pass out through the top. The standard resin tank must be shaken periodically to breakup these channels.

Connection

Connect a garden hose from site water to the bottom inlet valve and connect another hose from the top outlet to a system fill valve.

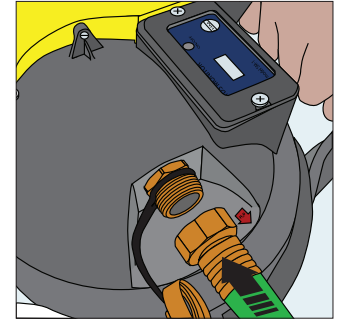

TDS conductivity meter

Visual inspection of the TDS conductivity meter during filling will determine when to replace the resin bags. Push the yellow lever to release lid.

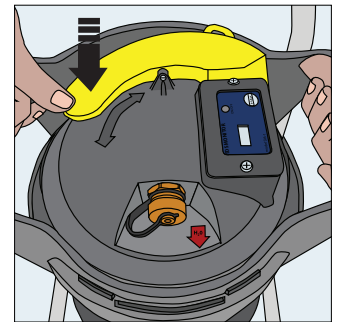
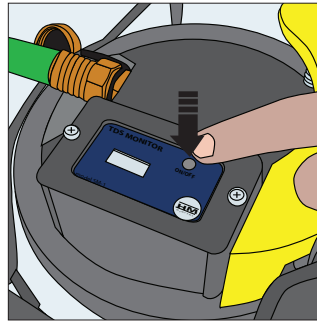

Replacing resin bags

Lift the lid up and off to remove the used resin bags. Replace with new resin bags (replace all bags, do not mix used with new bags).

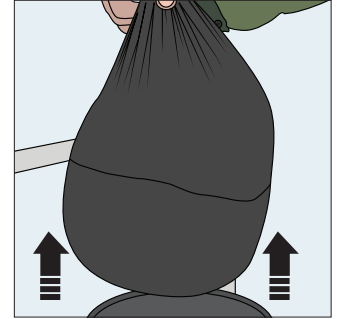
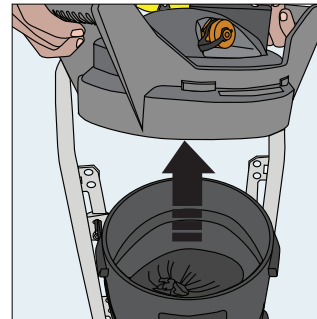

Storage

Install the lid after inserting new resin bags. Continue to operate, when filling is completed, drain the tank into floor or other drain, for storage. Installed cap on top outlet and close bottom inlet valve to keep resin moist.

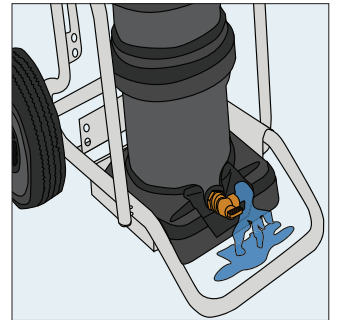
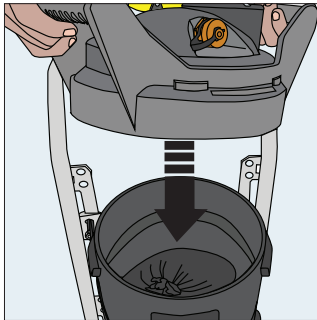

Problems associated with water quality

Lime scale deposits

Lime scale deposits are caused by the precipitation of calcium and magnesium carbonates minerals. Water contains calcium, magnesium and carbon dioxide in the form of **bicarbonates** (soluble substances).

An increase in water temperature causes part of the carbon dioxide to be released, thereby transforming the calcium and magnesium bicarbonates into **carbonates**, which are less soluble and subject to precipitation.

The resulting lime scale obstructs the passages and builds up on the heat exchangers, where it acts as a heat insulator, thus increasing fuel consumption required to heat the water to the desired temperature: A thin 0.04 inch film of lime scale reduces exchange efficiency and increases fuel consumption by 10%.

Lime scale deposits in pipes, furthermore, reduce the effective flow diameter and can also cause spot corrosion and failure.

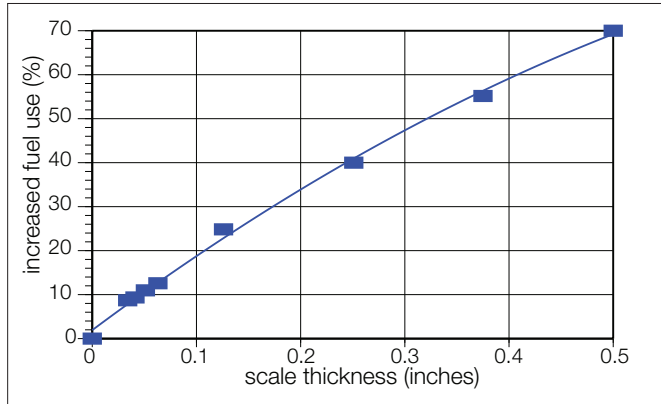

Total Dissolved Solids (TDS) is the presence of calcium and magnesium carbonate in addition to all the other dissolved minerals. TDS is expressed in parts per million (ppm).

Water hardness

The best predictor of the possible formation of lime scale is hardness, i.e. calcium and magnesium mineral content which are unstable and tend to precipitate easily.

Generally, hardness of the water, which is measured in **ppm of CaCO₃ in water**. Measurements are also expressed in **gpg** (grains per gallon): 1 gpg = 17.1 ppm of CaCO₃.

Water classification	Hardness (ppm)*
Slightly hard	< 60
Moderately hard	61 - 120
Hard	121 - 180
Very hard	181 - 250
Extremely Hard	> 250

* amount of CaCO₃ in water

Parameter comparison table

PARAMETER	FUNCTION	UNIT OF MEASUREMENT	POSSIBLE PROBLEMS
Total Dissolved Solids (TDS)	An electrical conductivity measurement of all dissolved mineral content (including calcium and magnesium) in the water	ppm	High values can cause lime scale deposits, accelerate corrosive reactions and increases galvanic attack.
Water hardness	A measurement of CaCO ₃ which is the amount of calcium and magnesium carbonate and bicarbonate in water.	ppm or gpg	High values can cause lime scale deposits.
potential Hydrogen	Defines, from a chemical point of view, whether the water is acidic, neutral or alkaline and is determined by the number of free hydrogen ions.	pH	pH values at the extremes of the scale indicate that corrosion is in progress.

Corrosion

Corrosion can be caused by various factors:

- parasitic currents
- dissolved oxygen
- electrolysis
- dissolved minerals

and may appear in various forms (spot or widespread corrosion), but is usually promoted by the simultaneous **presence of deposits** on metal surfaces.

Corrosion generally affects the system as a whole and not just individual parts of it. The appearance of corrosion in one point may therefore be symptomatic of general corrosion of the entire system.

The onset of corrosion is particularly fast in hot water systems, because the oxygen/metal reaction speed is directly proportional to temperature.

The speed and intensity of the corrosion process is closely connected with the presence of dissolved minerals in the water.

Electrical conductivity

The presence of dissociated minerals (positive ions and negative ions) turns water into an electrical conductor, whose conductivity varies according to the number of ions present. Although not all the minerals are dissociated in equal measure, therefore, **the electrical conductivity of the water is a indicator of its total dissolved solids expressed in ppm.**

Low conductivity equates to low minerals, whereas high conductivity denotes the presence of a large quantity of ions and hence of dissolved minerals.

pH

pH is a numerical indicator, which expresses the acidity or alkalinity (basicity) of a solution.

The pH scale ranges from 0 (acidic solution) to 14 (basic solution, i.e. with a high mineral content).

Since it is a logarithmic scale, a solution with pH 5 is 10 times more acidic than one with pH 4, and a solution with pH 3 is 100 times more acidic.

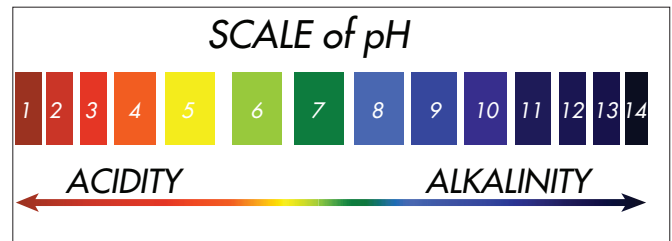

SCALE of pH



ACIDITY

ALKALINITY

Total water hardness

Water systems using groundwater as a source are concerned with water hardness, since as water moves through soil and rock it dissolves small amounts of naturally-occurring minerals and carries them into the groundwater supply. Water is a great solvent for calcium and magnesium, so if the minerals are present in the soil around a water-supply well, the hard water may be delivered to local water system. Water hardness varies throughout the United States and Canada (see map below).

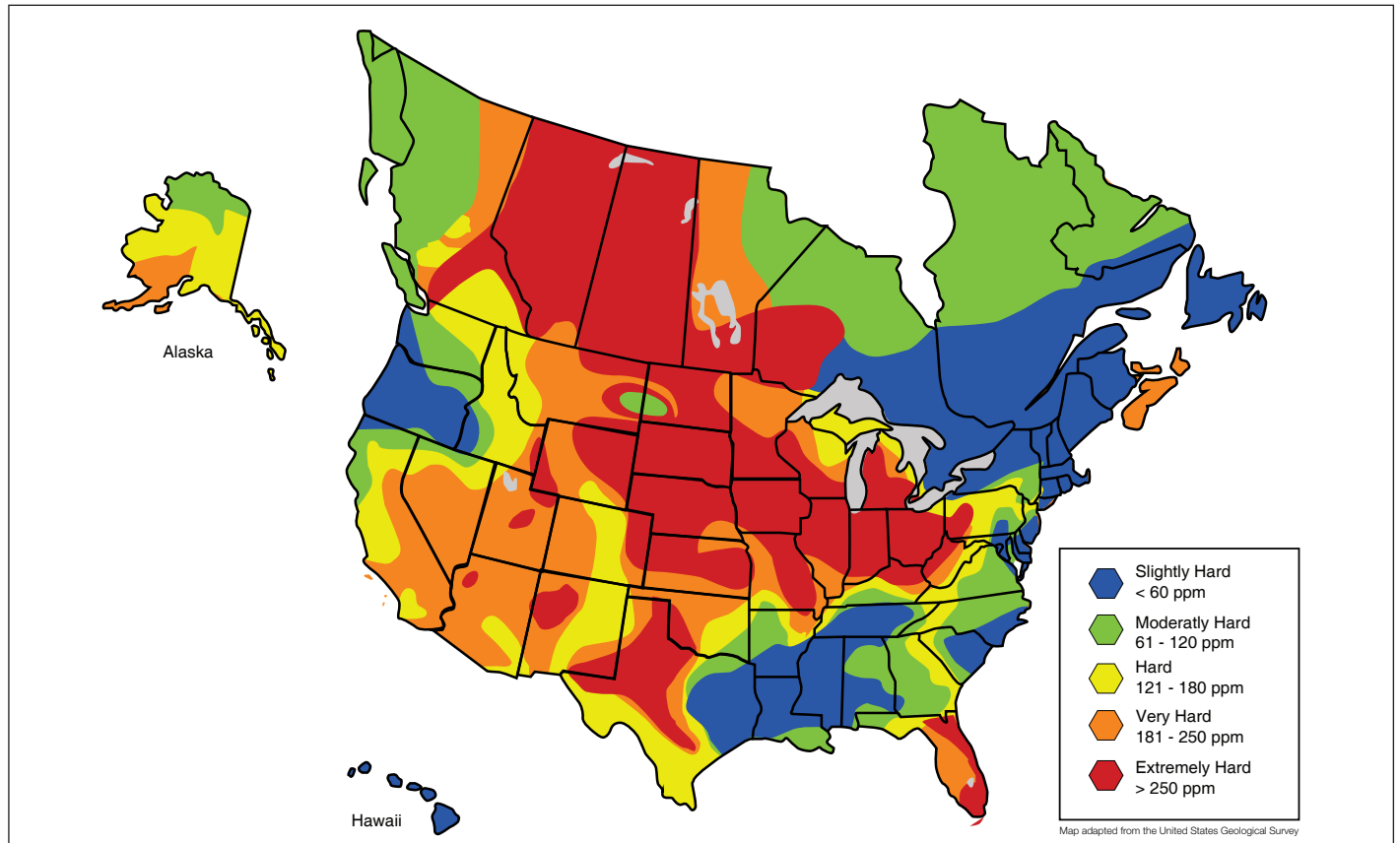

Water treatments

Water softening process, which replaces the calcium and magnesium minerals with sodium, which leaves the total quantity of minerals present in the treated water unchanged. In heating systems, subsequent chemical conditioning is therefore necessary. Chemical conditioning consists in introducing a dose chemical into the water circuit, to inhibit the corrosion process caused from the remaining high mineral content.

The water demineralization process, by contrast, not only eliminates the calcium and magnesium minerals, but also eliminates all minerals from the water, thus generating pure water that requires no further treatment.

	CHEMICAL DIFFERENCES	EFFECTS ON SYSTEM	RISK OF LIME SCALE	RISK OF CORROSION	pH	ELECTRICAL CONDUCTIVITY
Untreated water	Numerous minerals in solution, often including calcium ions and bicarbonates	As the temperature increases, the calcium carbonate precipitates and forms lime scale	<i>High</i>	<i>High</i>	Variable	Variable
Softened water	Has the same mineral content as untreated water but with low levels of calcium and magnesium, which are replaced by sodium	Only a minimal quantity of minerals may precipitate, but high conductivity causes galvanic attack.	<i>Medium - low</i> (high in the presence of aluminium)	<i>High</i>	Alkaline: Progressive increase in pH due to the presence of sodium carbonate	Same as untreated water
Softened water with chemical conditioning	Numerous minerals in solution, with the addition of corrosion-inhibitors and hardness stabilizers	As the temperature increases, a minimal quantity of minerals may precipitate	<i>Low</i>	<i>Medium</i>	Variable	Variable
Demineralized water	Almost entirely free from minerals in solution. Electrical conductivity is very low	No minerals to precipitate and the galvanic effects with different materials are drastically reduced	<i>Absent</i> (low in old systems)	<i>Absent</i>	< 8.5 pH	< 30 ppm

SOFTENING

A softener contain one type of cation resin only, to which the positive sodium (Na^+) ions bond.

The calcium (Ca^{2+}) and magnesium (Mg^{2+}) ions in the filling water bond with the resin and are replaced with sodium ions which are released into the water.

The treated water no longer contains calcium and magnesium ions (thereby preventing the formation of lime scale), but sodium and other minerals remain (possibility of corrosion).

It is therefore necessary to add specific chemical additives into the heating circuit to reduce corrosion.

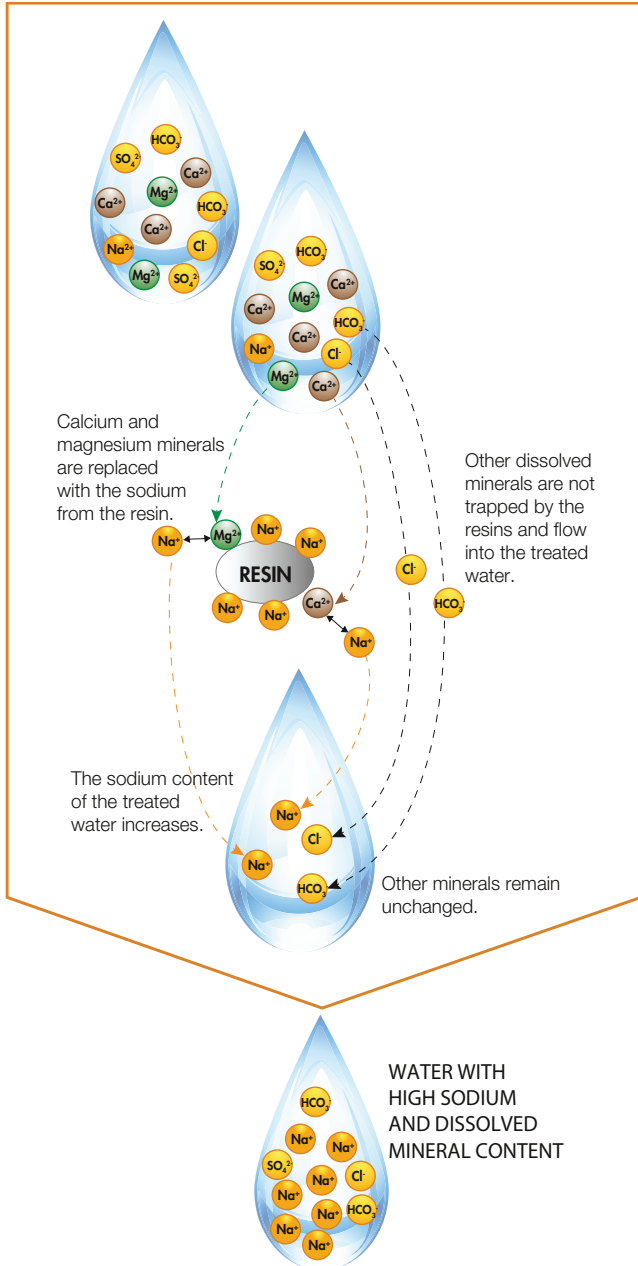

DEMINERALIZATION

The demineralization resin bags contain two different types of resins: anion resins, to which negative ions (OH^-) bond, and cation resins, to which positive ions (H^+) bond.

The positively charged minerals in the filling water (Na^+ , Ca^{2+} , Mg^{2+} , etc.) are replaced with positive ions H^+ . The negatively charged minerals (SO_4^{2-} , Cl^- , HCO_3^- , etc.) are replaced with negative ions (OH^-), the two then combine to form pure water (H_2O).

The resins bags retain the minerals and release H^+ and OH^- , which bond to form pure water. No chemicals additives are required.

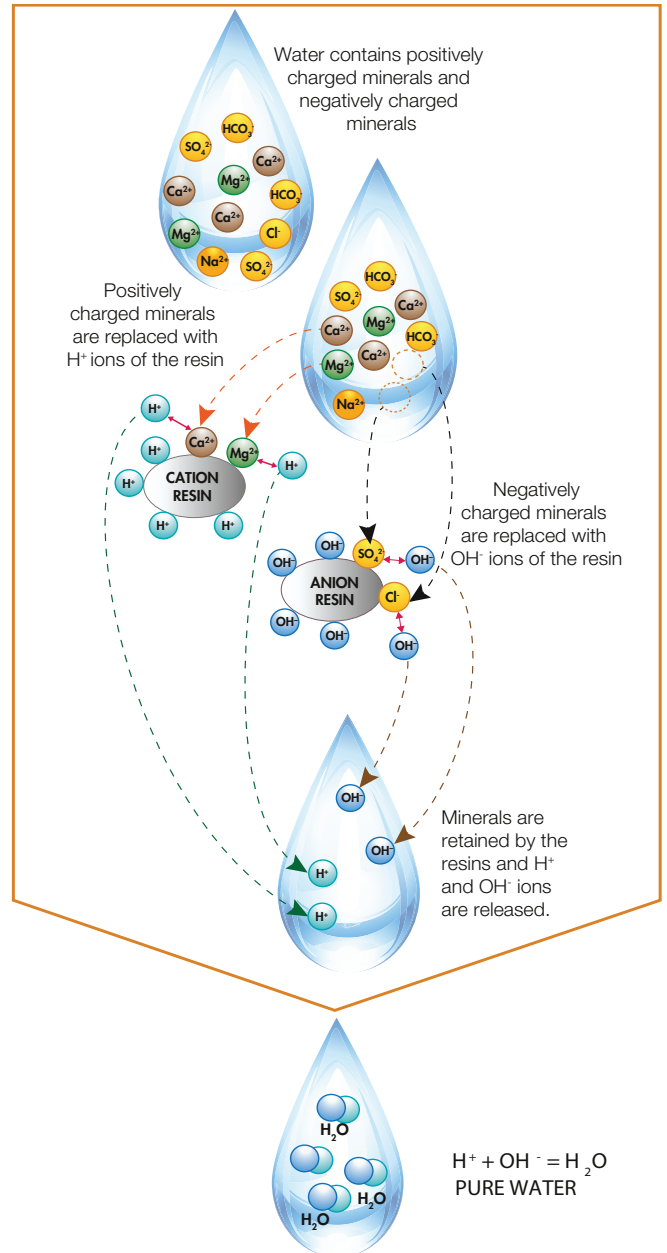

Treated water volume

To calculate the treated water volume capacity from a HYDROFILL unit, the TDS (ppm) of the untreated water must be known. The calculation must be made using the ppm value and the resin coefficient corresponding to each Hydrofill unit. The calculation results is then multiplied by 100 to arrive at the number of gallons of treated water produced by the HYDROFILL unit.

$$\text{Treated water (Gallons)} = \left(\frac{\text{resin coefficient}}{\text{ppm}} \right) \times 100$$

Example:
 Hydrofill unit: NA570912
 Hydrofill resin coefficient: 1800
 Untreated water: 200 ppm

$$\text{Treated water (Gallons)} = \left(\frac{1800}{200} \right) \times 100 = 900 \text{ gallons}$$

Code	Description	Resin coefficient *
NA570912	Two resin bags	1800
NA570924	Four resin bags	3600

* based on treated water with TDS < 30 ppm at 5 gpm fill rate

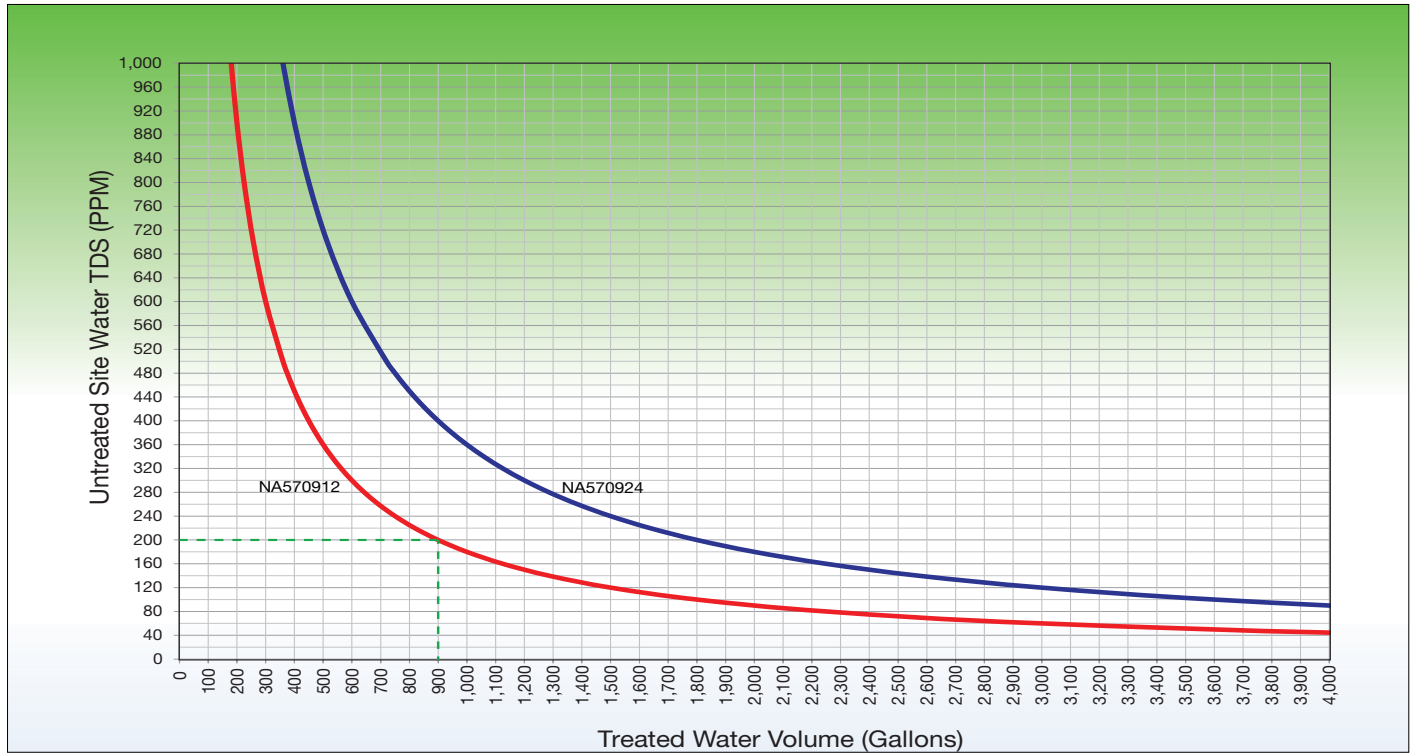

Treatment checking

The water exiting the treatment unit has a electrical conductivity of less than 30 ppm. After approximately 4 - 6 weeks of system operation (with water circulation and heating cycles) the electrical conductivity and pH values stabilize: it is therefore necessary to check these parameters to ensure that treatment is effective and that the requirements specified by the equipment manufacturers are met.

Multi- parameter tester

TDS and pH measuring kit

TDS and pH value can be measured using the measuring kit (code NA575002): simply take a sample of water from the operating circuit and immerse the instrument's sensor in it. The instrument can measure pH, TDS electrical conductivity and temperature value. The kit also includes the calibration solutions.



pH measurement

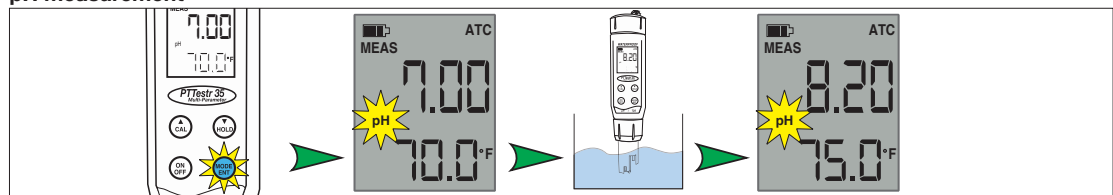

TDS electrical conductivity measurement

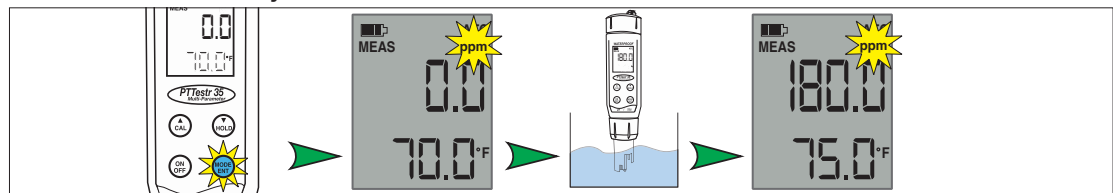

Application diagrams

Once-through filling method

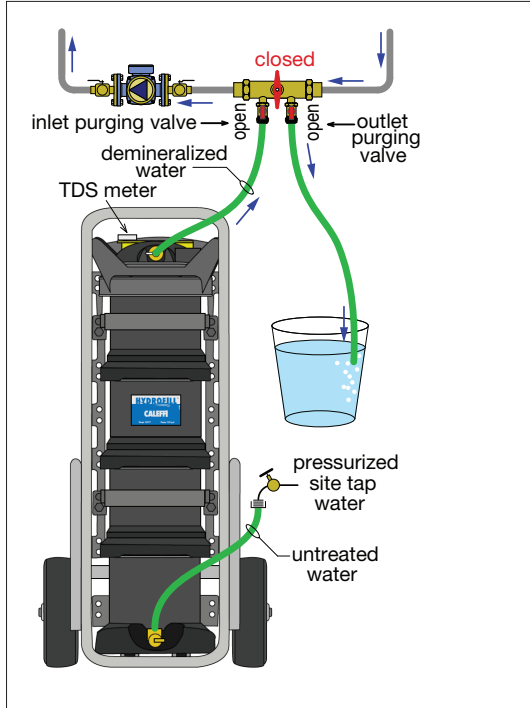

The HYDROFILL™ unit is connected as shown on the left. Untreated water from a pressurized site tap passes through an inlet hose connected to the bottom hose connection on the unit. It is demineralized as it flows upward through the resin beads and exits through the upper hose connection. It flows through another hose to the inlet purging valve on the hydronic system. As the demineralized water enters the system, air is pushed out through the open outlet purging valve. A hose from this valve is routed to a clean pail or barrel to capture any water leaving the system during purging. Maintain flow through the unit into the system until a steady stream of water exits the outlet purging valve. The bulk air should now be purged from the system. Close the inlet and outlet purging valves simultaneously. During fill and purging, periodically check the TDS meter on the unit to verify that it does not rise above 30 PPM.

Purging gases from the system

In tap water, gases such as oxygen and carbon dioxide are attached to minerals. Demineralization removes most minerals from water, but it does not remove dissolved gases including oxygen and carbon dioxide. When the gases are released, carbon dioxide gas will combine with the demineralized water to form a very weak carbonic acid (H_2CO_3), which lowers the water's pH. Removing these gases will increase and help stabilize the pH of the demineralized water.

Therefore, once the demineralization process has been completed, the system should be operated with the heat source on and all air separation and venting devices active. Whenever possible, the heat source should produce an outlet temperature of 140°F or higher. This heating and circulation should be maintained for at least one hour. Raising the temperature of the system water helps force dissolved gases out of solution. These gas molecules will coalesce to form micro-bubbles that can be captured by a high-performance air separator, such as a 551 series DISCAL, and ejected them from the system.

Recirculation filling method

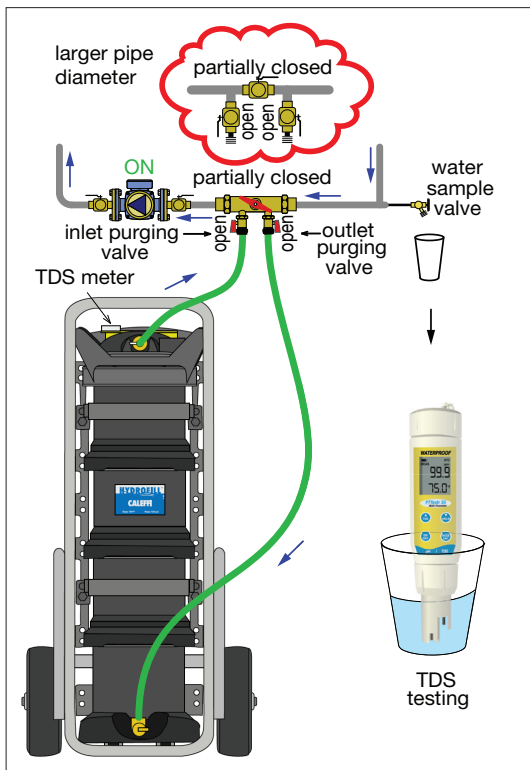

When the fill flow rate needed to purge the air from the system is more than the maximum allowable flow rate through the HYDROFILL™, the system can be demineralized after site water is filled into the system. A hose connects from the outlet purging valve on the system to the lower inlet connection on the unit. Another hose connects from the upper outlet on the unit to the inlet purging valve on the system.

Open the outlet purging valve to allow water to flow from the system into the bottom inlet of the unit. The water will flow up through the resin bead column, hold the yellow lever down to release the air inside the unit. Top outlet hose connects to the inlet purging valve.

The in-line ball valve between the inlet and outlet purging valve should be partially closed to force some flow through the unit.

Turn on the system circulator(s) to create flow in the system, but the boiler or chiller should be left off. The TDS reading on the HYDROFILL monitor is that of the water leaving the unit and not all the water in the system.

Allow this recirculation flow to continue for several minutes. Then, draw a sample of system water from another drain valve in the system into a clean plastic or glass cup. Test the TDS level of this sample using a hand-held meter (code NA575002). When the TDS level of the system water reaches the desired value, turn off pump, close purging valves and disconnect the HYDROFILL.

Once the demineralization process has been completed, the system should be operated with the heat source on, circulator(s) on and all air separation and venting devices active. Whenever possible, the heat source should produce an outlet temperature of 140°F or higher. This heating and circulation should be maintained for at least one hour. Raising the temperature of the system water helps force dissolved gases out of solution. These gas molecules will coalesce to form micro-bubbles that can be captured by a high-performance air separator, such as a 551 series DISCAL, and ejected them from the system.

We reserve the right to change our products and their relevant technical data, contained in this publication, at any time and without prior notice.



Caleffi North America, Inc.
3883 W. Milwaukee Road
Milwaukee, WI 53208
Tel: 414-238-2360 · Fax: 414-238-2366
sales@caleffi.com · www.caleffi.com
© Copyright 2016 Caleffi North America, Inc.