

LEGIOMIX®

Electronic mixing valve, union connections



6000 series

Submittal Data 03601 NA — Issue Date 01/2020

Application

The electronic mixing valve is used in centralized systems that produce and distribute domestic hot water. It maintains the temperature of the domestic hot water delivered to the user when there are variations in the temperature and pressure of the hot and cold water at the inlet or in the draw-off flow rate. The LEGIOMIX® electronic mixing valve provides precise temperature control over very low and very high flow rate demand, minimal pressure drop with a ball valve control element, automatic self-cleaning to prevent scale formation and easy-to-use digital interface with data logging, alarming and status indication. The LEGIOMIX electronic mixing valve is furnished with a controller with LCD user interface that provides a set of programs for circuit thermal disinfection to kill Legionella. The controller is configurable via keypad, or local or remote computer. Depending on the type of system and habits of the user, temperature levels and operation times can be programmed as desired. In addition, it comes standard with monitoring and remote control connections.



Typical Specification

Furnish and install on the plans and described herein, a Caleffi 6000 series LEGIOMIX electronic mixing valve as manufactured by Caleffi. Each valve with controller must be designed with programmable thermal disinfection. The valve design must include a DZR low-lead brass body, chrome-plated ball and peroxide-cured EPDM hydraulic seals. The actuator must be 3-wire floating fail-in-place with integral position indicator, 24 VAC 50/60 Hz with self-extinguishing VO cover, protection class IP 65 (NEMA 4/4X). The controller must be 24 VAC 50/60 Hz with adjustment temperature range 70 - 185°F (20 - 85°C) and disinfection temperature range 100 - 185°F (40 - 85°C). Provided with two NTC element 10.000 ohm stainless steel temperature sensors for mixed outlet water temperature and return water temperature, strap-on style, for recirculation. Choice of 11 languages with set of programs for selectable automatic scheduling circuit thermal disinfection to kill Legionella, configurable via keypad, or local or remote controller; with additional functions of daily ball rotation cycle, flush valve relay output, data logging (40 day FIFO loop buffer), alarming, and status indication. The valve must be ICC-ES certified to ASSE 1017, CSA B15.3, NSF 372-2011, low lead laws and listed by ICC-ES; and meet codes IPC and UPC for use in accordance with the US and Canadian plumbing codes. Each valve shall be Caleffi model 6000 series or approved equal. (See product instructions for specific installation information.)

Dimensions

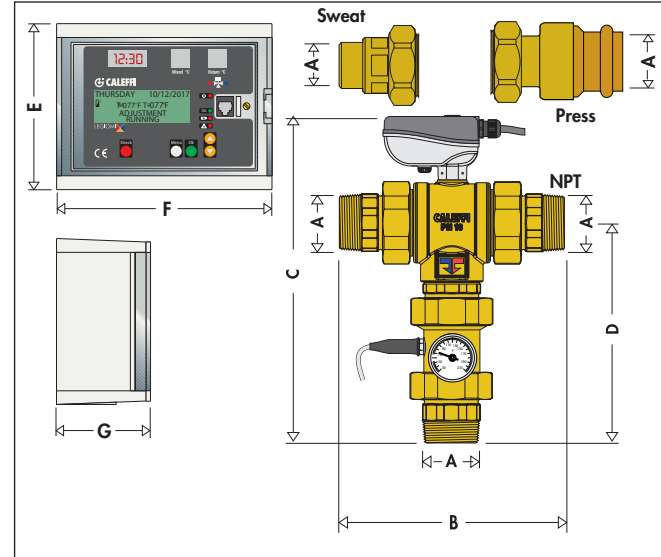

Code	A	B	C	D	E	F	G	Wt (lb)
600054A	¾" MNPT	5"	9 ³⁄₈"	5 ³⁄₈"	5 ½"	7"	4"	5.1
600059A	¾" sweat	4 ¾"	9 ¼"	5 ¼"				5.1
600056A	¾" press	5 ³⁄₈"	9 ⁹⁄₁₆"	5 ⁹⁄₁₆"				5.1
600064A	1" MNPT	6 ¼"	11"	6"				7.3
600069A	1" sweat	4 ¾"	10 ¼"	5 ¼"				7.3
600066A	1" press	7"	11 ³⁄₈"	6 ³⁄₈"				7.3
600074A	1 ¼" MNPT	7 ¼"	11 ⁷⁄₈"	6 ¼"				8.2
600079A	1 ¼" sweat	5 ¾"	11 ¹⁄₈"	5 ½"				8.2
600076A	1 ¼" press	9 ¾"	13 ¹⁄₈"	7 ½"				8.2
600084A	1 ½" MNPT	9 ¹⁄₈"	14 ³⁄₈"	9 ½"				21.0
600089A	1 ½" sweat	7 ⁷⁄₈"	13 ¹⁄₈"	8 ¼"				21.0
600086A	1 ½" press	10 ¹⁄₈"	14 ⁷⁄₈"	10"				21.0
600094A	2" MNPT	9 ½"	14 ½"	7 ⁵⁄₁₆"				22.0
600099A	2" sweat	8"	13 ¹¹⁄₁₆"	6 ½"				22.0
600096A	2" press	13 ¾"	16 ⁵⁄₈"	9 ⁷⁄₁₆"				22.0

For press models,

Lay lengths: size ¾" - 5 ⁹⁄₁₆"; 1"-5 ½"; size 1 ¼" - 7 ¾"; size 1 ½" - 7 ³⁄₈"; size 2"-10 ¾".

Provide with optional stainless steel inlet port check valve assembly with a acetal plastic check valve insert and NBR o-ring, field installed. Caleffi codes NA10366 (1", 1 ¼"), NA10367 (1 ½, 2").

Provide with Modbus-to-BACnet gateway for BAS integration, code NA10520.

Recommended Flow Rates (gpm/lpm)					
Size	¾"	1"	1¼"	1½"	2"
Minimum (1)	2.2 / 8.3	3.1 / 11.7	4.4 / 16.6	6.6 / 25	8.8 / 33.3
Design Flow (2)	27 / 102	58 / 220	66 / 250	93 / 352	131 / 495
Maximum (3)	43 / 172	94 / 356	107 / 405	152 / 575	215 / 814
Cv	9.7	21	24	34	47

- (1) To ensure stable operation and a $\pm 3^\circ\text{F}$ accurate temperature control Minimum flow rate is 0 gpm when recirculation flow rate is greater than or equal to the valve size minimum flow rating.
- (2) Suggested maximum flow rate for optimum modulating control (at 7.5 psid pressure drop).
- (3) Maximum recommended differential pressure is 20 psid to ensure stable operation and accurate temperature control.

Technical specifications

Valve body

Materials: - Body: DZR low-lead brass
 - Ball: low-lead brass, chrome-plated
 - Hydraulic seals: peroxide-cured EPDM

Max. body pressure rating (static): 230 psi (16 bar)
 Max. operating pressure: 150 psi (10 bar)
 Max. inlet temperature: 212°F (100°C)
 Temperature gauge scale: 30 - 210°F
 Suitable fluids: water
 Max. water hardness: 10 grains

Main connections: -NPT male, sweat & press union: ¾", 1", 1¼", 1½" & 2"

Actuator, 3-wire floating fail-in-place

Electric supply: 24 VAC - 50/60 Hz
 Power consumption: 6 VA
 Protection cover: self-extinguishing VO
 Protection class: IP 65 (NEMA 4/4X)
 Ambient temperature range: 14 - 130°F (-10 - 55°C)
 Electric supply cable length: 31½" (0.8 m)
 Max. distance for control signal wire:
 500 ft (150 m) cable 2 conductor x AWG 18
 800 ft (250 m) cable 2 conductor x AWG 16

Controller, LCD user interface/display

Materials: - Housing: self-extinguishing ABS, color white RAL 1467
 - Cover: self-extinguishing SAN, smoked transparent
 Electric supply: 24 VAC (min 21.6, max 26.0 VAC)- 50/60 Hz
 Power consumption: 6.5 VA
 Adjustment temperature range: 70 - 185°F (20 - 85°C)
 Disinfection temperature range: 100 - 185°F (40 - 85°C)
 Ambient temperature range: 32 - 120°F (0 - 50°C)

Protection class: IP 54 (wall mounting)
 (Class II appliance)

Mounting bracket: DIN rail

Contact rating (R1, R3, R4): 5 A resistance, 2 A inductance / 24 V
 Mixing valve control: 5 A resistance, 2 A inductance / 24 V
 Alarm relay (R2): 5 A resistance, 2 A inductance / 24 V

Fuses: 1 (main): 80 mA
 Fuses: 2 (mixing valve): 1 A
 Charge reserve: 15 days in the event of electric supply failure,
 with a 3 cell rechargeable 3.6 V 140 mAh buffer battery
 Battery recharging time: 72 hours
 Approvals: CE, FCC part 15

Temperature sensors

Body material: stainless steel
 Type of sensitive element: NTC
 Working temperature range: 14 - 260°F (-10 - 125°C)
 Resistance: 1000 Ohms at 77° F (25° C)
 Time constant: 2.5
 Max. distance for mixed outlet or return (recirculation) sensor:
 500 ft (150 m) cable 2 conductor x AWG 18
 800 ft (250 m) cable 2 conductor x AWG 16

Mixing valve performance

Accuracy: $\pm 3^\circ\text{F}$ ($\pm 2^\circ\text{C}$)
 Max. operating differential pressure (dynamic): 20 psi (1.4 bar)
 Max. ratio between inlet pressures (H/C or C/H): 2.1

Certifications

1. ASSE 1017/CSA B125.3, certified by ICC-ES, file PMG-1357.
2. NSF/ANSI 372-2011, Drinking Water System Components-Lead Content Reduction of Lead in Drinking Water Act, California Health and Safety Code 116875 S.3874, Reduction of Lead in Drinking Water Act, certified by ICC-ES, file PMG-1360.

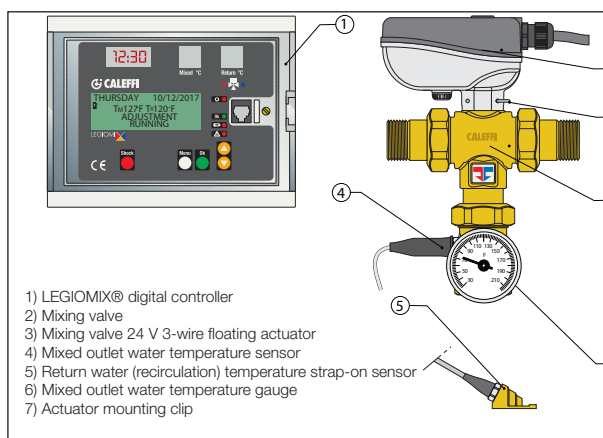

- 1) LEGIOMIX® digital controller
- 2) Mixing valve
- 3) Mixing valve 24 V 3-wire floating actuator
- 4) Mixed outlet water temperature sensor
- 5) Return water (recirculation) temperature strap-on sensor
- 6) Mixed outlet water temperature gauge
- 7) Actuator mounting clip

Package contents

- Digital controller, consisting of housing and base for electric connection
- DIN bar and mounting wall anchors
- Mixing valve with temperature gauge
- 3-wire floating Actuator
- Mixed outlet water temperature sensor
- Return water temperature strap-on sensor
- Spare fuses
- Installation and commissioning manual

We reserve the right to change our products and their relevant technical data, contained in this publication, at any time and without prior notice. Contractors should request production drawings if prefabricating the system.

Job name _____
 Job location _____
 Engineer _____
 Mechanical contractor _____
 Contractor's P.O. No. _____
 Representative _____

Size _____
 Quantity _____
 Approval _____
 Service _____
 Tag No. _____
 Notes _____